

ITEM NO.	PART NUMBER	DESCRIPTION	QTY.	CUT
1	LTN-PST-1W20-1-HO-TOP	22 GAUGE	1	
2	LTN-PST-1W20-1-HO-UPPER SIDE	22 GAUGE	4	
3	LTN-PST-1W20-1-HO-UPPER SIDE TAB	22 GAUGE	4	
4	LTN-PST-1W20-1-HO-LOWER SIDE DOOR	22 GAUGE	1	
5	LTN-PST-1W20-1-HO-DRIVER BRACKET	22 GAUGE	1	
6	LTN-PST-1W20-1-HO-TUBE BRACKET	22 GAUGE	1	
7	LTN-PST-1W20-1-HO-UPPER TRIM PLATE	22 GAUGE	1	
8	LTN-PST-1W20-1-HO-LOWER TRIM PLATE	22 GAUGE	1	
9	LTN-PST-1W20-1-HO-LOWER SIDE	22 GAUGE	4	
10	LTN-PST-1W20-1-HO-BOTTOM	22 GAUGE	1	
11	LTN-PST-1W20-1-HO-.5" ROUND TUBE	5/8" ROUND ALUMINUM TUBE	1	
12	LTN-PST-1W20-1-HO-SQUARE TUBE	1" SQUARE ALUMINUM TUBE	1	
13	LTN-PST-1W20-1-HO-BAR SUPPORT	1/4"X1/2" SUPPORT FLAT BAR	1	
14	LTN-PST-1W20-1-HO-ACRYLIC	ACRYLIC	5	
15	POST FITTER	3" STEEL POST FITTER	1	
16	SPUN ACCENT	BRASS	1	
17	BULLET ACCENT	BRASS ACCENT	1	
18	AltILED PN1010_RevD	LED	4	
19	ESPEN VEL29070MVH-1	DRIVER	1	

UNLESS OTHERWISE SPECIFIED:

DIMENSIONS ARE IN INCHES
 TOLERANCES:
 FRACTIONAL ± .003
 ANGULAR: MACH ± .01 BEND ±
 TWO PLACE DECIMAL ±
 THREE PLACE DECIMAL ± .001

INTERPRET GEOMETRIC
 TOLERANCING PER:

MATERIAL

FINISH

ALL BEND RADIUS .030"

APPLICATION

DO NOT SCALE DRAWING

NAME DATE

DRAWN
 CHECKED
 ENG APPR.
 MFG APPR.

Q.A.
 COMMENTS:

FIXTURE HEAD

TITLE:

LTN-PST-1W20-1-HO

SIZE DWG. NO.

REV

A TICKET 25585

SCALE: 1:10 WEIGHT:

SHEET 1 OF 12

EVERGREEN LIGHTING



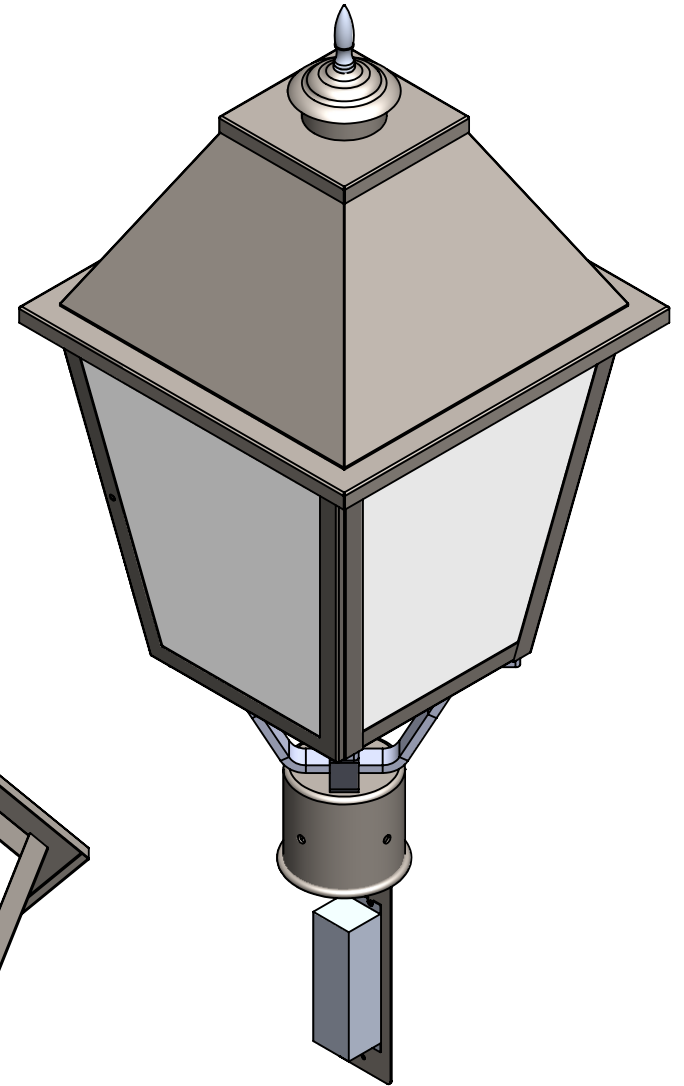
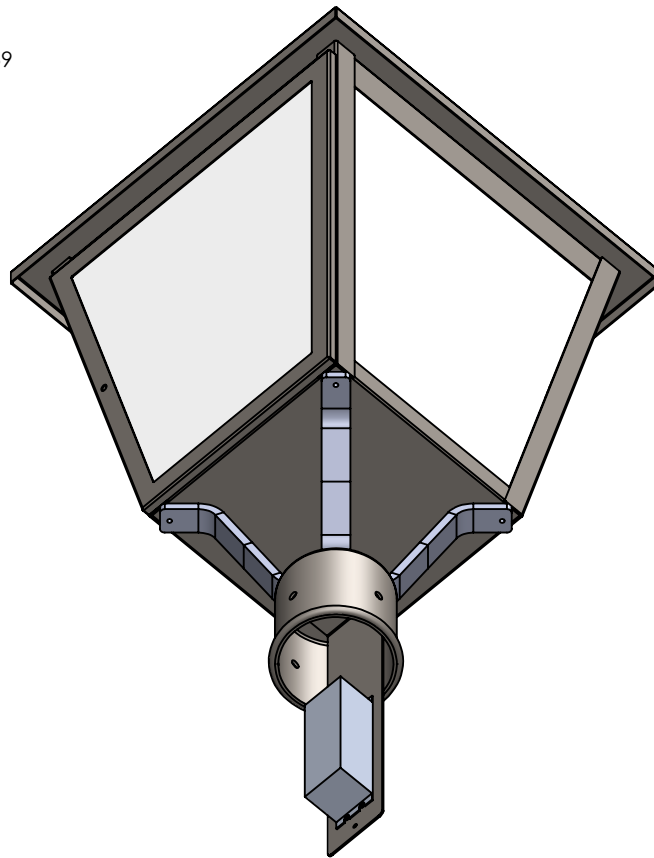
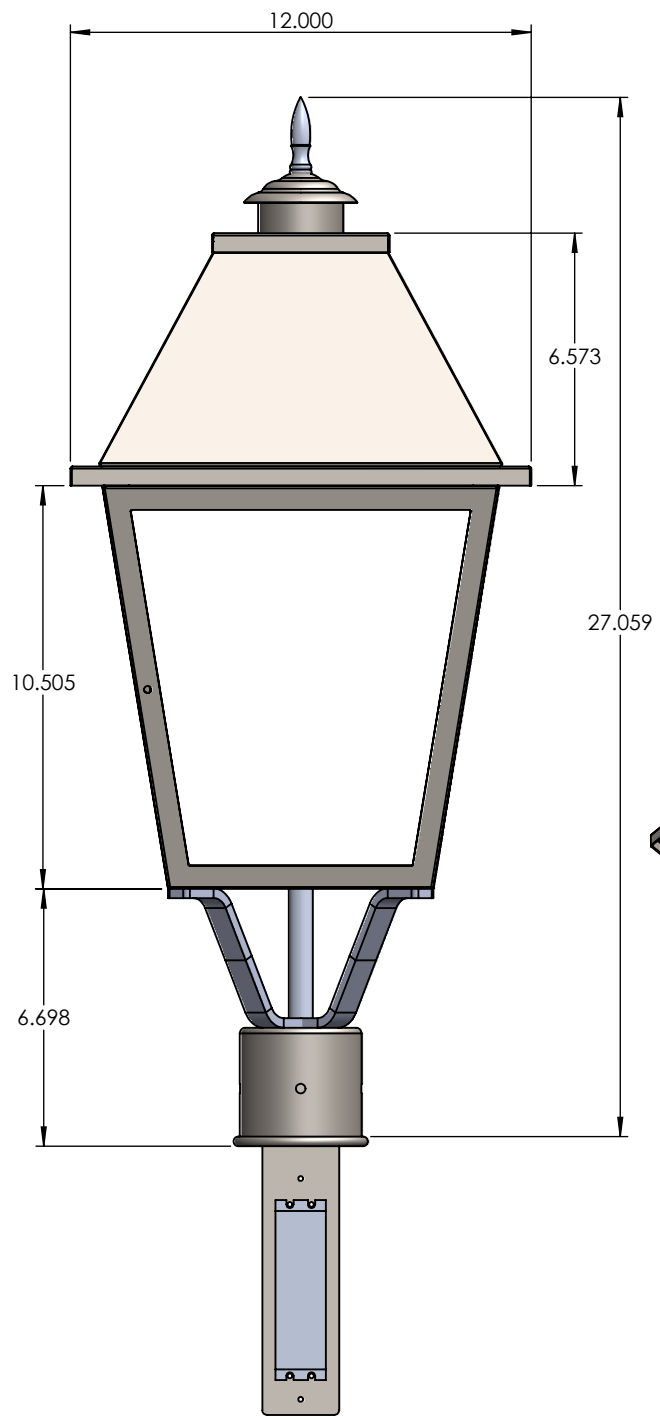

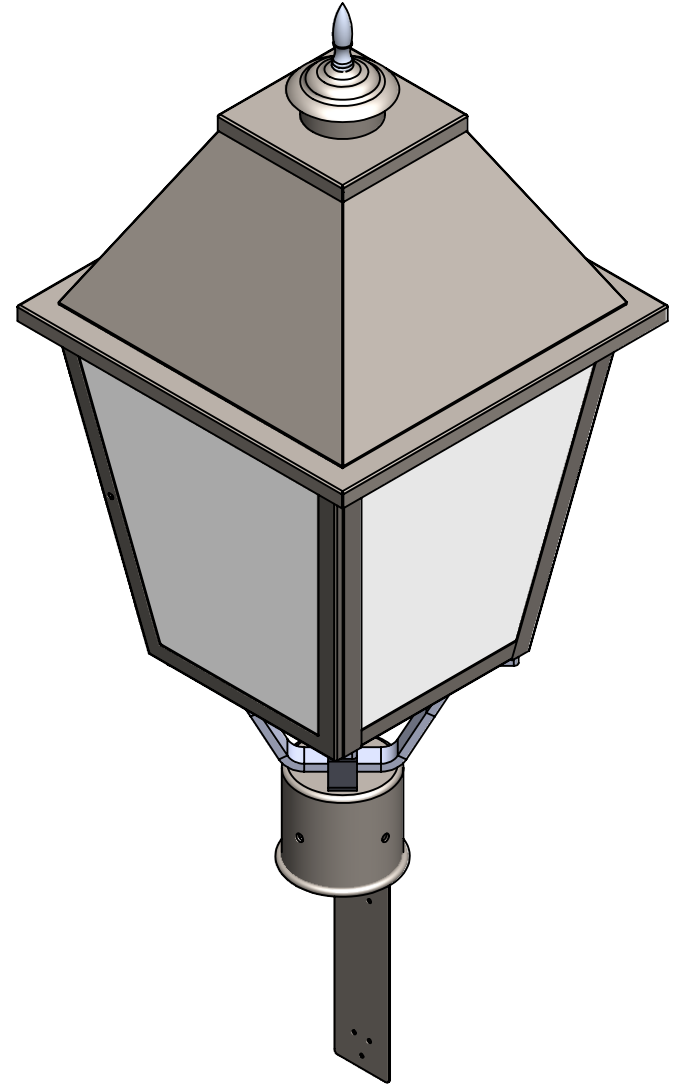
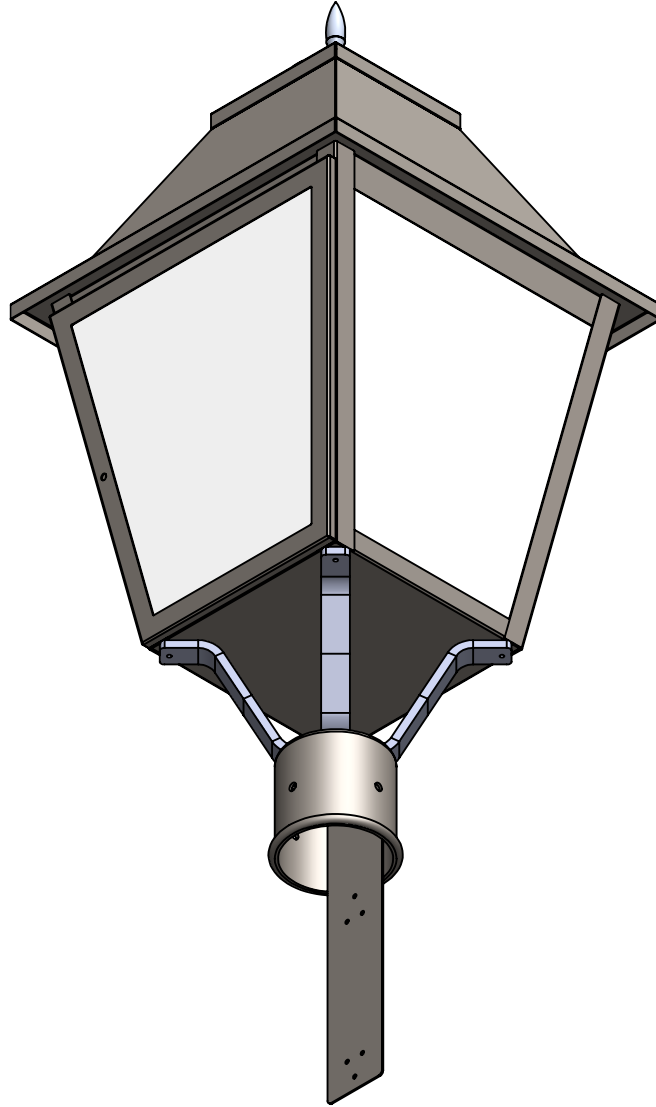
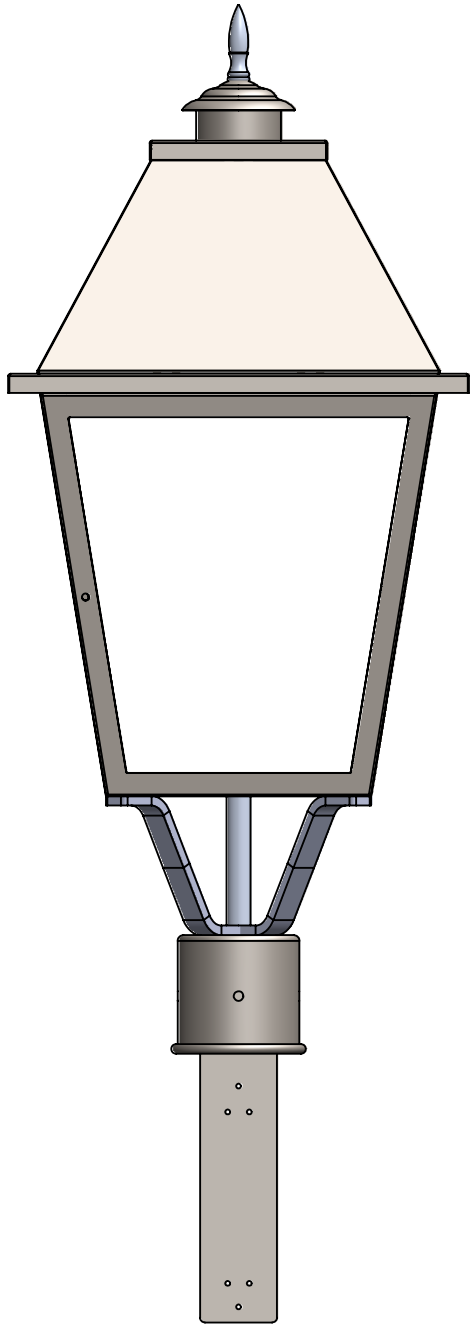

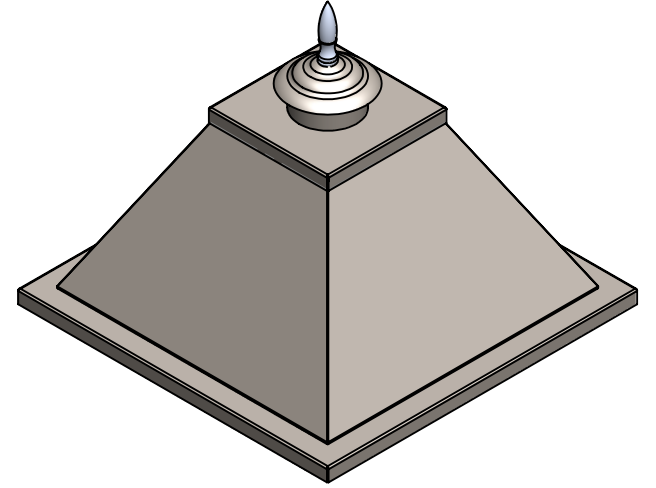
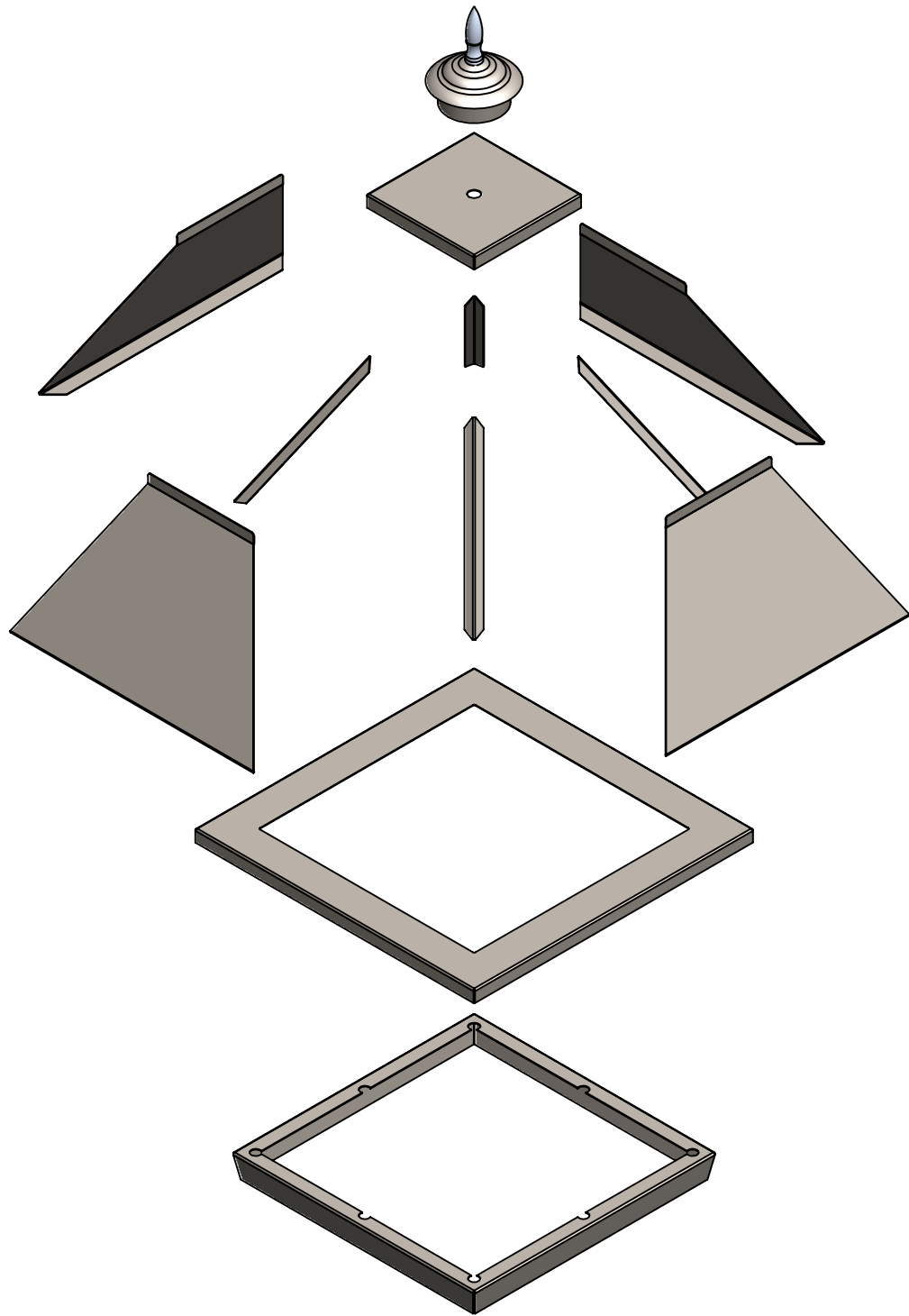

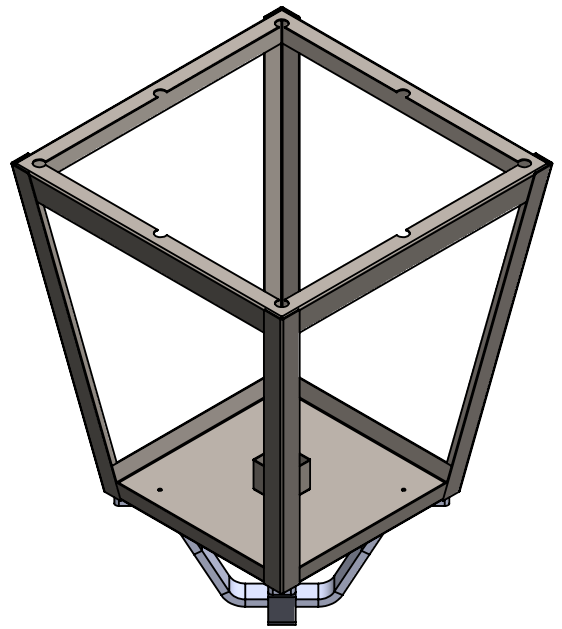
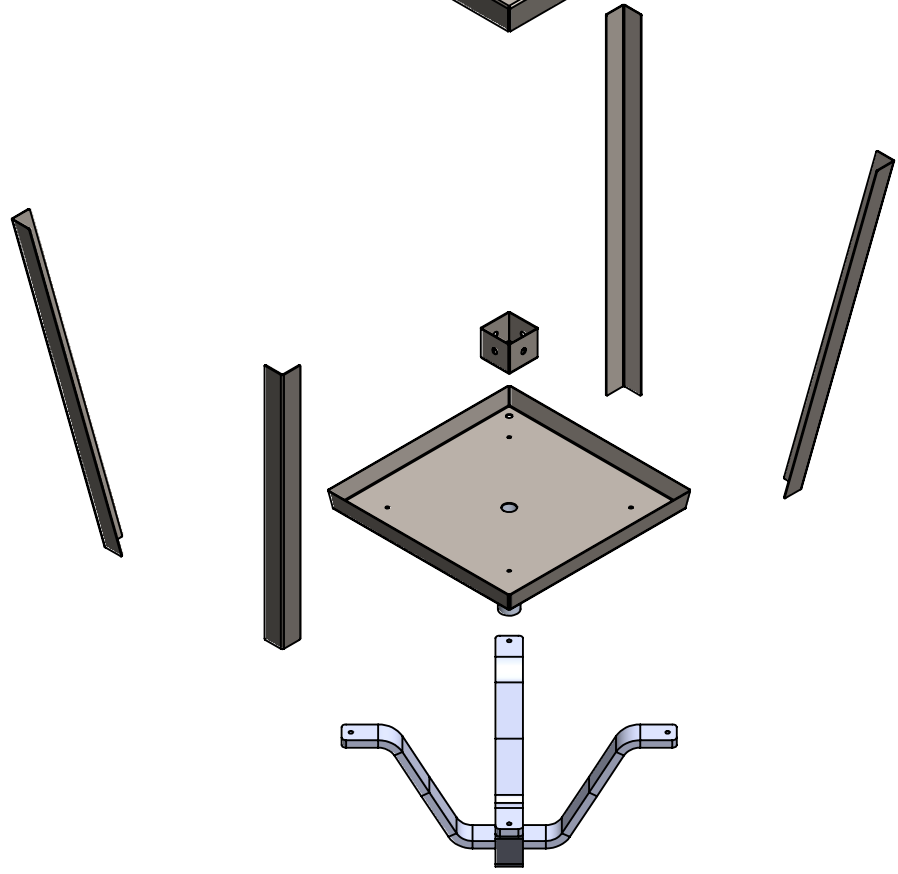
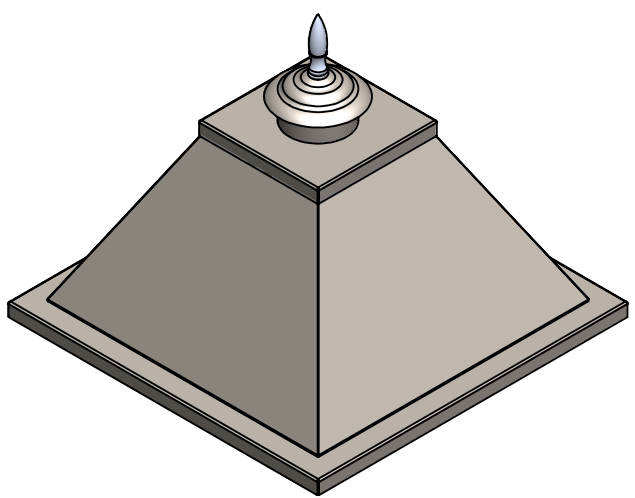
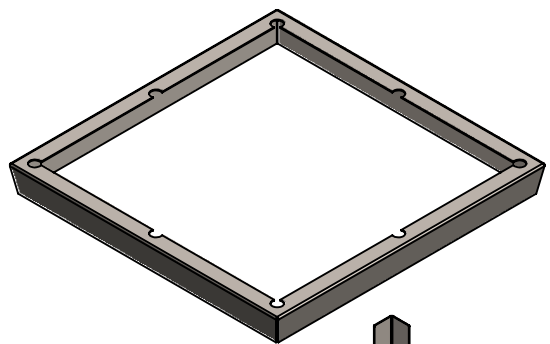

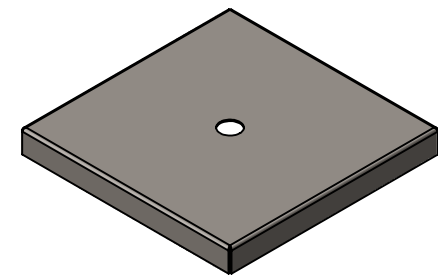
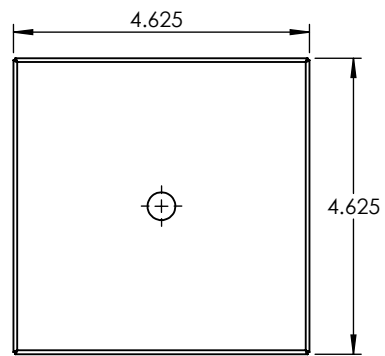
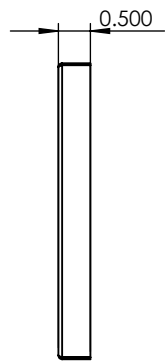
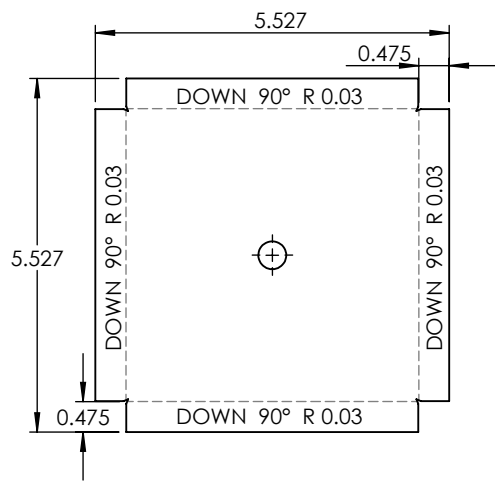

PROPRIETARY AND CONFIDENTIAL
 THE INFORMATION CONTAINED IN THIS DRAWING IS THE SOLE PROPERTY OF <INSERT COMPANY NAME HERE>. ANY REPRODUCTION IN PART OR AS A WHOLE WITHOUT THE WRITTEN PERMISSION OF <INSERT COMPANY NAME HERE> IS PROHIBITED.

		UNLESS OTHERWISE SPECIFIED:	NAME	DATE	22 GAUGE	
		DIMENSIONS ARE IN INCHES TOLERANCES: FRACTIONAL ± ANGULAR: MACH ± BEND ± TWO PLACE DECIMAL ± THREE PLACE DECIMAL ±	DRAWN			
		INTERPRET GEOMETRIC TOLERANCING PER:	CHECKED			
		MATERIAL	ENG APPR.			
		FINISH	MFG APPR.			
NEXT ASSY	USED ON		Q.A.		SIZE DWG. NO. REV	
APPLICATION		DO NOT SCALE DRAWING	COMMENTS:		SCALE: 1:3 WEIGHT: SHEET 6 OF 12	

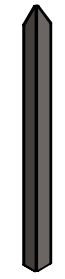
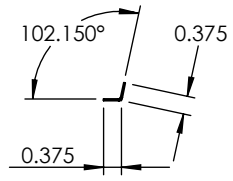
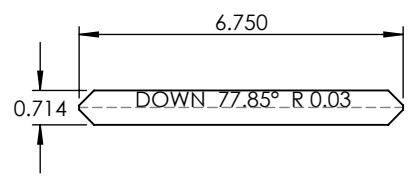
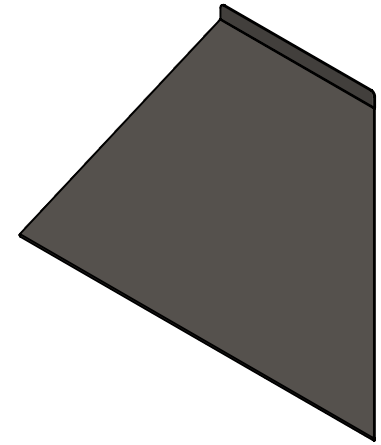
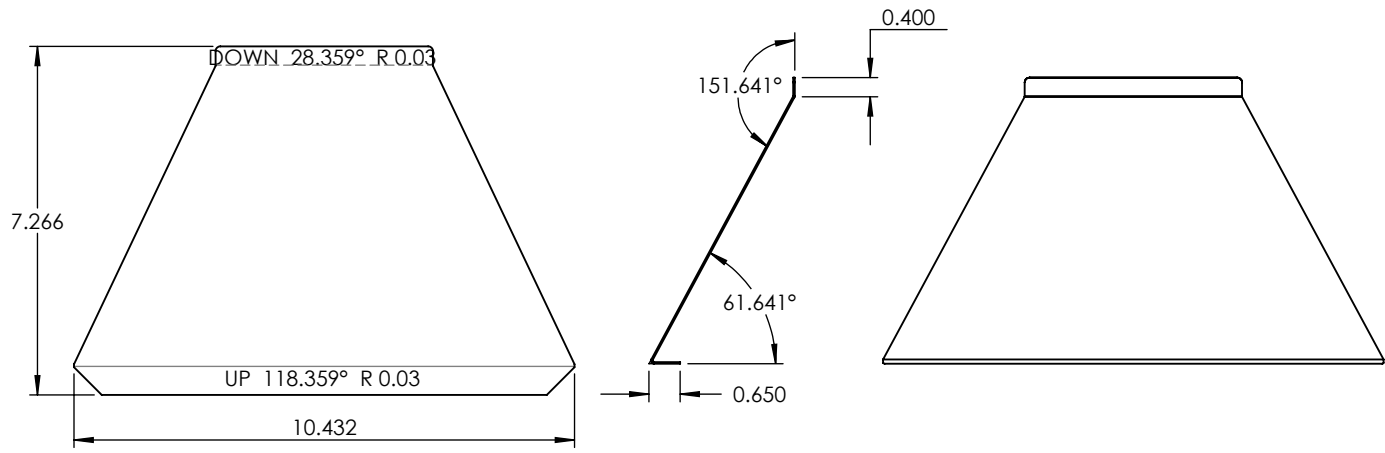

PROPRIETARY AND CONFIDENTIAL
 THE INFORMATION CONTAINED IN THIS DRAWING IS THE SOLE PROPERTY OF <INSERT COMPANY NAME HERE>. ANY REPRODUCTION IN PART OR AS A WHOLE WITHOUT THE WRITTEN PERMISSION OF <INSERT COMPANY NAME HERE> IS PROHIBITED.

		UNLESS OTHERWISE SPECIFIED:	NAME	DATE
		DIMENSIONS ARE IN INCHES	DRAWN	
		TOLERANCES:	CHECKED	
		FRACTIONAL ±	ENG APPR.	
		ANGULAR: MACH ± BEND ±	MFG APPR.	
		TWO PLACE DECIMAL ±	Q.A.	
		THREE PLACE DECIMAL ±	COMMENTS:	
		INTERPRET GEOMETRIC TOLERANCING PER:		
		MATERIAL		
NEXT ASSY	USED ON	FINISH		
APPLICATION		DO NOT SCALE DRAWING		

22 GAUGE		
TITLE:		
LTN-PST-1W20-1-HO		
SIZE	DWG. NO.	REV
A		
SCALE: 1:4	WEIGHT:	SHEET 7 OF 12

5

4

3

2

1

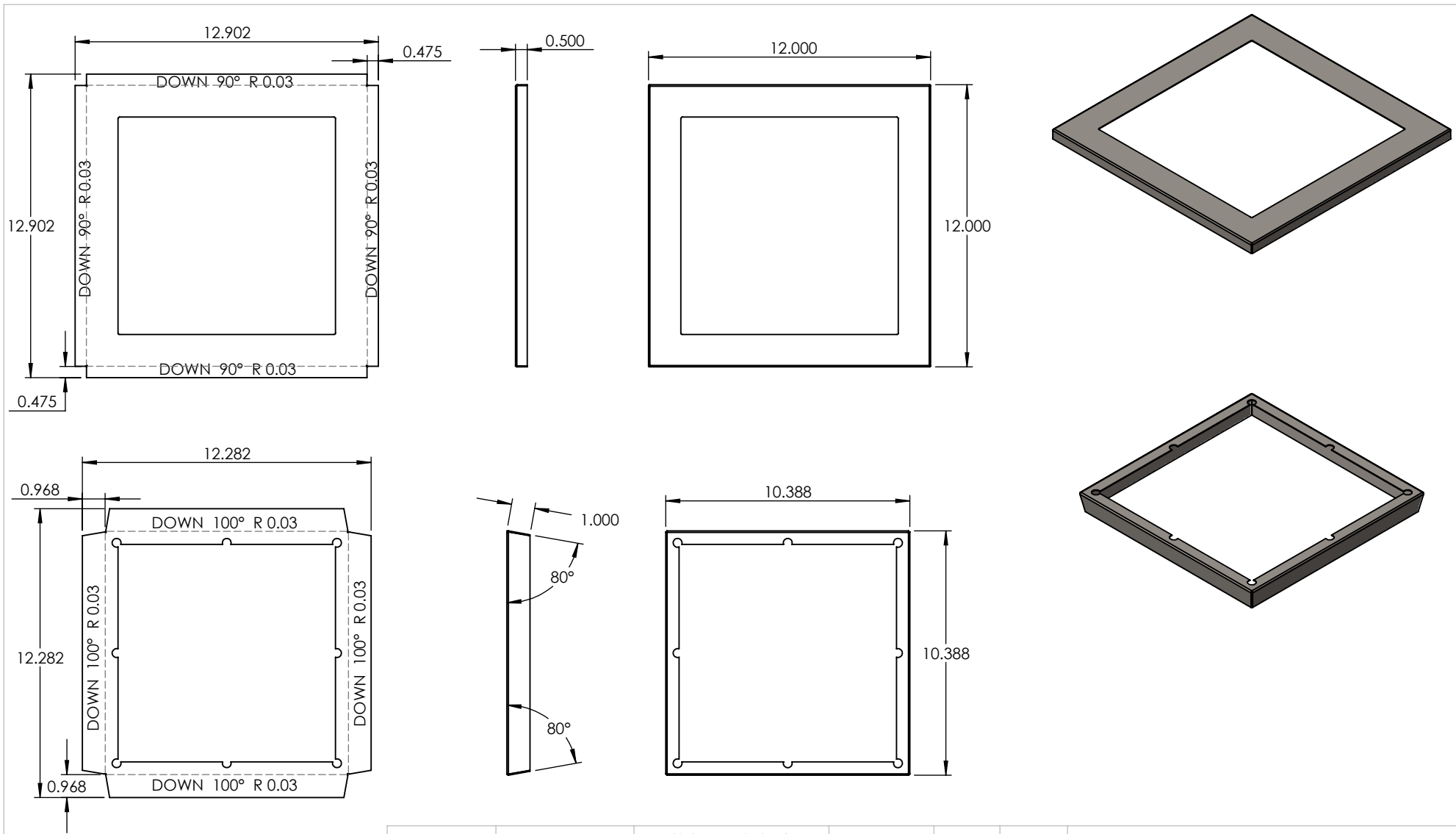

PROPRIETARY AND CONFIDENTIAL
 THE INFORMATION CONTAINED IN THIS DRAWING IS THE SOLE PROPERTY OF <INSERT COMPANY NAME HERE>. ANY REPRODUCTION IN PART OR AS A WHOLE WITHOUT THE WRITTEN PERMISSION OF <INSERT COMPANY NAME HERE> IS PROHIBITED.

		UNLESS OTHERWISE SPECIFIED:	NAME	DATE	22 GAUGE							
		DIMENSIONS ARE IN INCHES TOLERANCES: FRACTIONAL ± ANGULAR: MACH ± BEND ± TWO PLACE DECIMAL ± THREE PLACE DECIMAL ±	DRAWN				TITLE: LTN-PST-1W20-1-HO					
		INTERPRET GEOMETRIC TOLERANCING PER:	CHECKED									
		MATERIAL	ENG APPR.									
		FINISH	MFG APPR.									
NEXT ASSY	USED ON		Q.A.		<table border="1" style="width: 100%;"> <tr> <td style="width: 15%; text-align: center;">SIZE</td> <td style="width: 60%;">DWG. NO.</td> <td style="width: 25%; text-align: center;">REV</td> </tr> <tr> <td style="text-align: center; font-size: 2em;">A</td> <td></td> <td></td> </tr> </table>		SIZE	DWG. NO.	REV	A		
SIZE	DWG. NO.	REV										
A												
APPLICATION		DO NOT SCALE DRAWING	COMMENTS:		SCALE: 1:6	WEIGHT:	SHEET 8 OF 12					

5

4

3

2

1

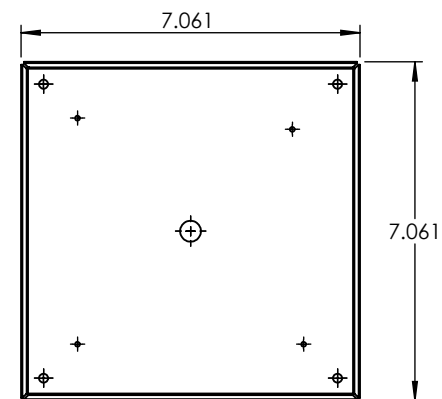
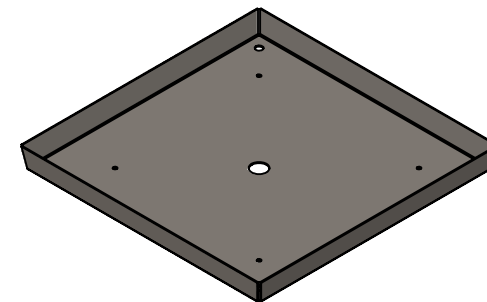
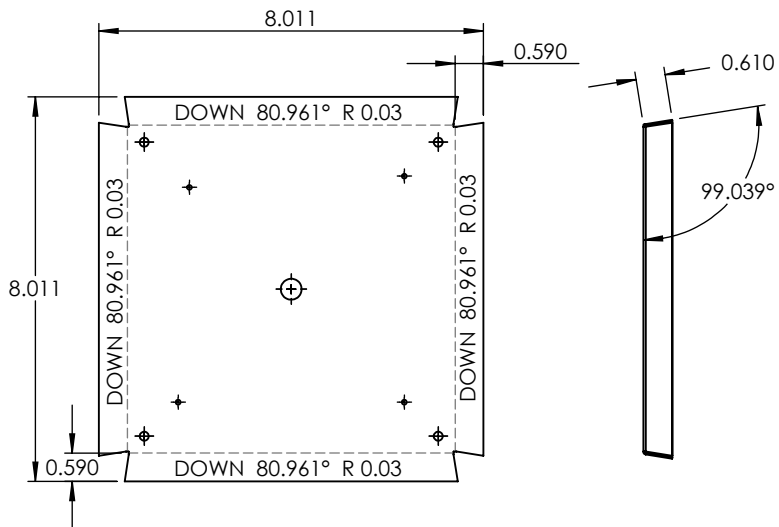
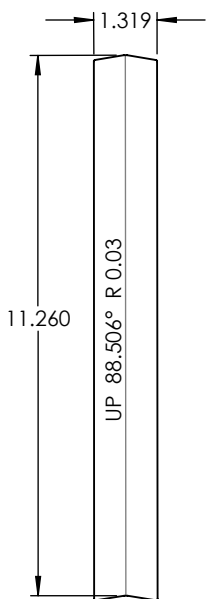
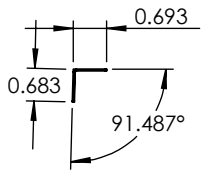

PROPRIETARY AND CONFIDENTIAL
 THE INFORMATION CONTAINED IN THIS DRAWING IS THE SOLE PROPERTY OF <INSERT COMPANY NAME HERE>. ANY REPRODUCTION IN PART OR AS A WHOLE WITHOUT THE WRITTEN PERMISSION OF <INSERT COMPANY NAME HERE> IS PROHIBITED.

		UNLESS OTHERWISE SPECIFIED:		NAME	DATE	22 GAUGE		
		DIMENSIONS ARE IN INCHES TOLERANCES: FRACTIONAL ± ANGULAR: MACH ± BEND ± TWO PLACE DECIMAL ± THREE PLACE DECIMAL ±	DRAWN					TITLE:
		INTERPRET GEOMETRIC TOLERANCING PER:	CHECKED			LTN-PST-1W20-1-HO		
		MATERIAL	ENG APPR.					
		FINISH	MFG APPR.			SIZE	DWG. NO.	REV
NEXT ASSY	USED ON		Q.A.			A		
APPLICATION		DO NOT SCALE DRAWING	COMMENTS:				SCALE: 1:4	WEIGHT:

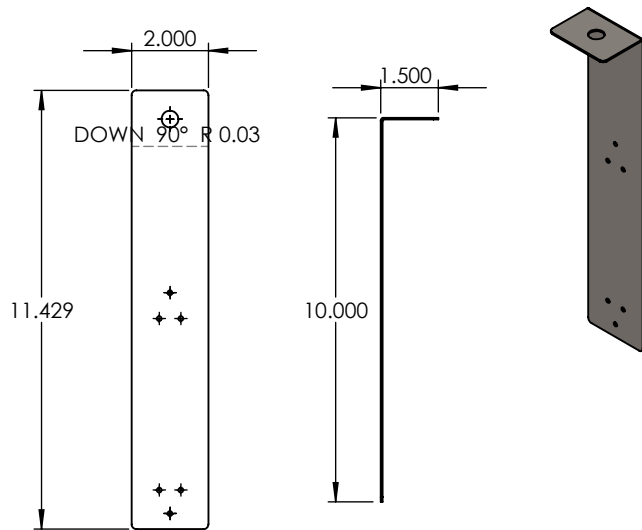
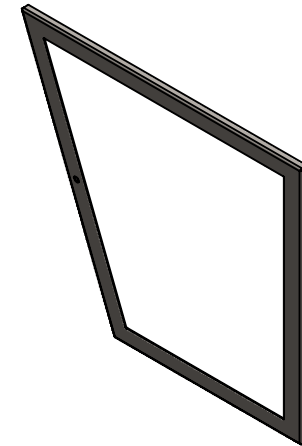
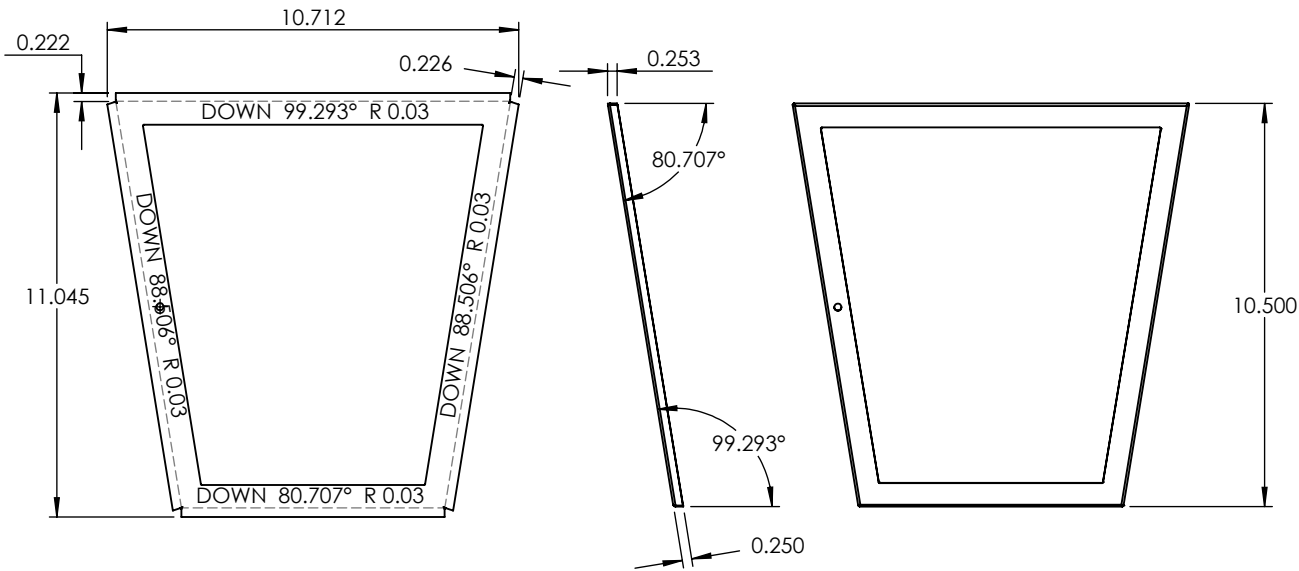

UNLESS OTHERWISE SPECIFIED:

DIMENSIONS ARE IN INCHES
 TOLERANCES:
 FRACTIONAL ±
 ANGULAR: MACH ± BEND ±
 TWO PLACE DECIMAL ±
 THREE PLACE DECIMAL ±

INTERPRET GEOMETRIC
 TOLERANCING PER:

MATERIAL

FINISH

DO NOT SCALE DRAWING

NAME

DATE

22 GAUGE

TITLE:

LTN-PST-1W20-1-HO

SIZE
A

DWG. NO.

REV

SCALE: 1:5

WEIGHT:

SHEET 10 OF 12

PROPRIETARY AND CONFIDENTIAL
 THE INFORMATION CONTAINED IN THIS
 DRAWING IS THE SOLE PROPERTY OF
 <INSERT COMPANY NAME HERE>. ANY
 REPRODUCTION IN PART OR AS A WHOLE
 WITHOUT THE WRITTEN PERMISSION OF
 <INSERT COMPANY NAME HERE> IS
 PROHIBITED.

NEXT ASSY

USED ON

APPLICATION

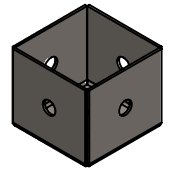
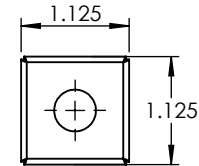
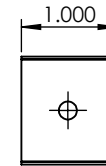
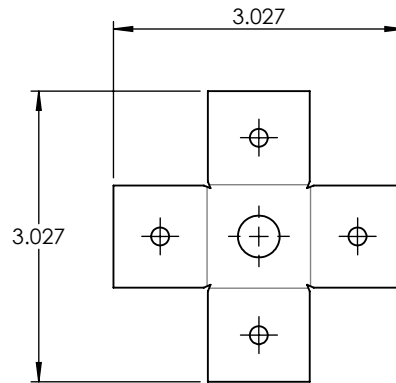
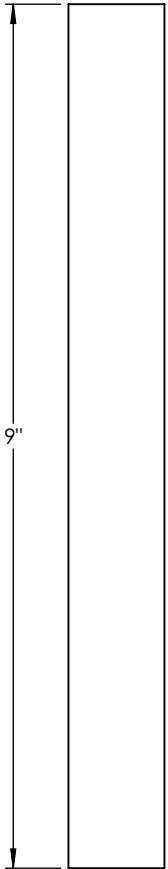
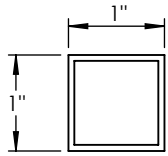

PROPRIETARY AND CONFIDENTIAL
 THE INFORMATION CONTAINED IN THIS DRAWING IS THE SOLE PROPERTY OF <INSERT COMPANY NAME HERE>. ANY REPRODUCTION IN PART OR AS A WHOLE WITHOUT THE WRITTEN PERMISSION OF <INSERT COMPANY NAME HERE> IS PROHIBITED.

		UNLESS OTHERWISE SPECIFIED:		NAME	DATE
		DIMENSIONS ARE IN INCHES	DRAWN		
		TOLERANCES:	CHECKED		
		FRACTIONAL ±	ENG APPR.		
		ANGULAR: MACH ± BEND ±	MFG APPR.		
		TWO PLACE DECIMAL ±	Q.A.		
		THREE PLACE DECIMAL ±	COMMENTS:		
		INTERPRET GEOMETRIC TOLERANCING PER:			
		MATERIAL			
		FINISH			
NEXT ASSY	USED ON				
APPLICATION		DO NOT SCALE DRAWING			

22 GAUGE		
TITLE:		
LTN-PST-1W20-1-HO		
SIZE	DWG. NO.	REV
A		
SCALE: 1:2	WEIGHT:	SHEET 11 OF 12

