

ITEM NO.	PART NUMBER	DESCRIPTION	QTY.	CUT
1	SHWL-43-30W-MN-WF-STB-WET-41K-FRAME	ALUMINUM 0.0635"	1	
2	SHWL-43-30W-MN-WF-STB-WET-41K-BACKPLATE	ALUMINUM 0.0635"	1	
3	SHWL-43-30W-MN-WF-STB-WET-41K-BACKPLATE SPACER	ALUMINUM 0.0635"	1	
4	SHWL-43-30W-MN-WF-STB-WET-41K-FIREPLATE	ALUMINUM 0.0635"	1	
5	SHWL-43-30W-MN-WF-STB-WET-41K-LENS RAIL	ALUMINUM 0.0635"	1	
6	SHWL-43-30W-MN-WF-STB-WET-41K-CAP TOP	ALUMINUM 0.0635"	2	
7	SHWL-43-30W-MN-WF-STB-WET-41K-SPUN CAP	ALUMINUM 0.0635"	2	
8	SHWL-43-30W-MN-WF-STB-WET-41K-VERTICAL BAR	ALUMINUM 0.500" PLATE	1	
9	SHWL-43-30W-MN-WF-STB-WET-41K-ALUMINUM BAR	1/2" SQUARE ALUMINUM BAR	1	
10	SHWL-43-30W-MN-WF-STB-WET-41K-ACRYLIC	ACRYLIC	1	
11	Espen VEL19070MVH-1	DRIVER	1	
12	ESPEL VEL29070MVH-1	DRIVER	1	
13	AIRGILED PN105B-11-SS	LED	6	

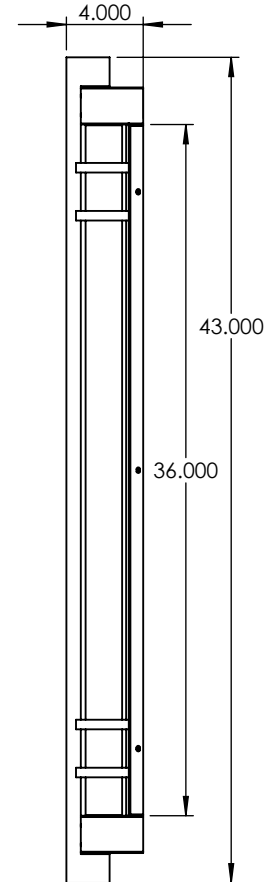
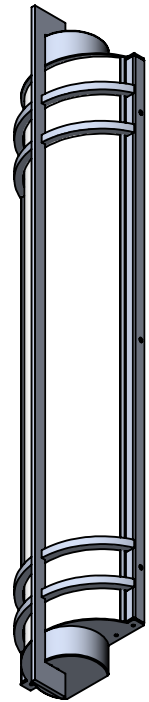
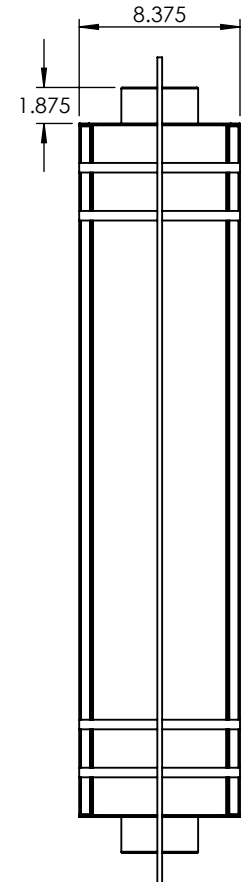
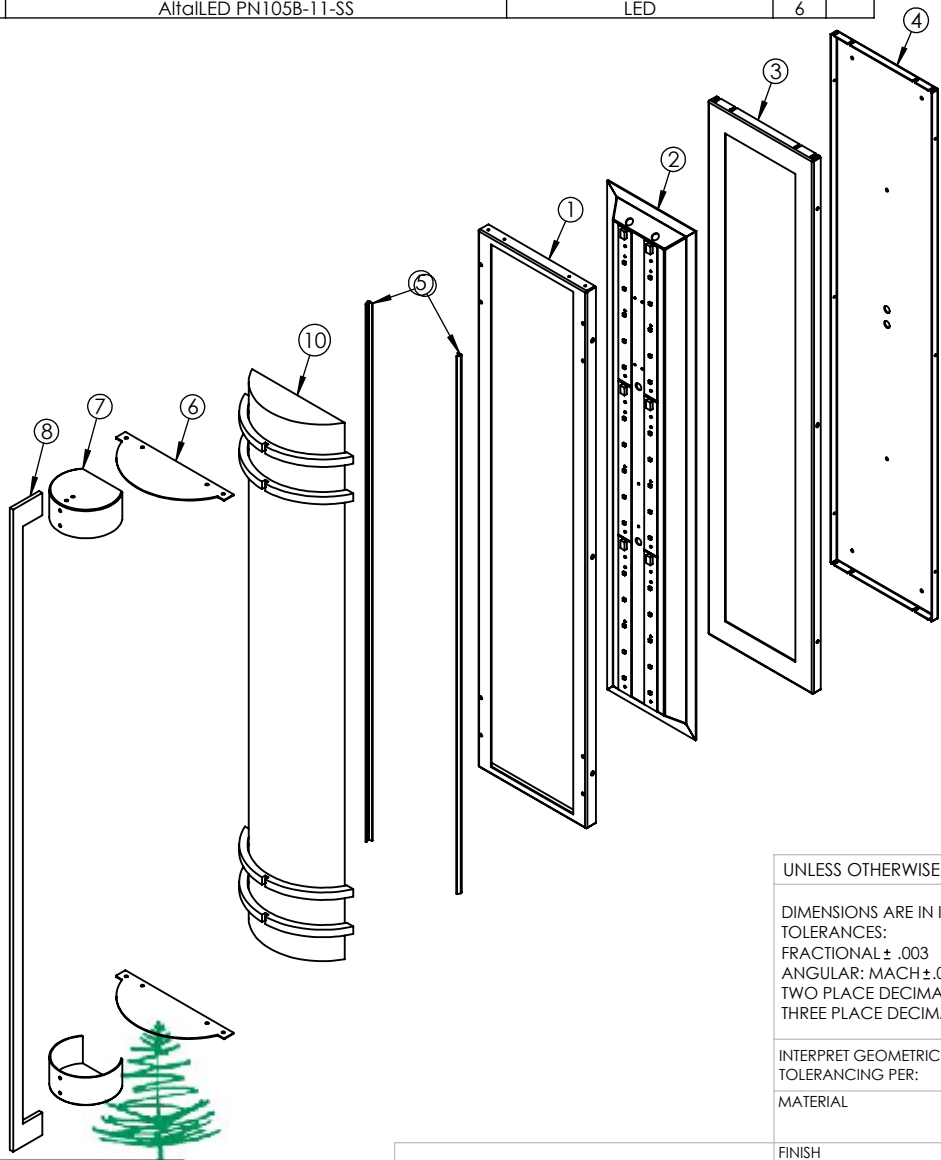

EVERGREEN LIGHTING

ALL BEND RADIUS .030"

APPLICATION

DO NOT SCALE DRAWING

UNLESS OTHERWISE SPECIFIED:

DIMENSIONS ARE IN INCHES
 TOLERANCES:
 FRACTIONAL ± .003
 ANGULAR: MACH ± .01 BEND ±
 TWO PLACE DECIMAL ±
 THREE PLACE DECIMAL ±.001

INTERPRET GEOMETRIC
 TOLERANCING PER:

MATERIAL

FINISH

NAME DATE

DRAWN

CHECKED

ENG APPR.

MFG APPR.

Q.A.

COMMENTS:

TITLE:

SHWL-43-30W-MN-WF-STB-WET-41K

SIZE DWG. NO.

A TICKET 25595

REV

SCALE: 1:10 WEIGHT:

SHEET 1 OF 11

5

4

3

2

1

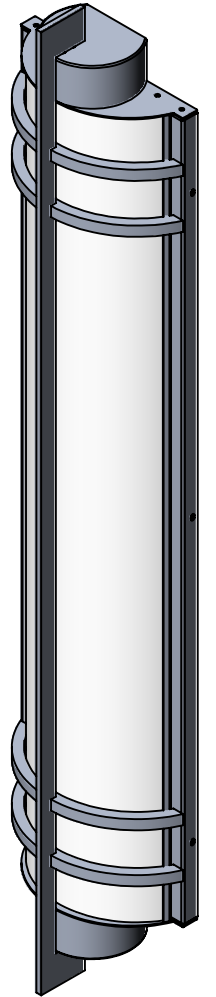
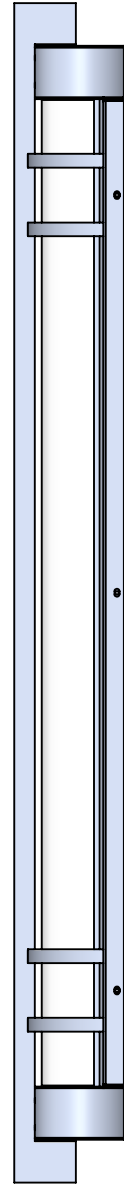
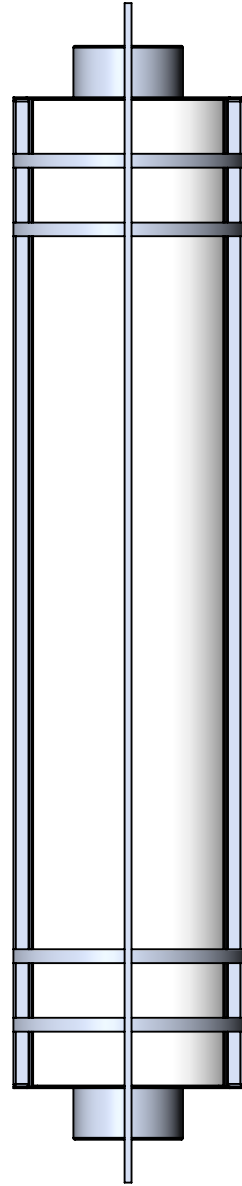
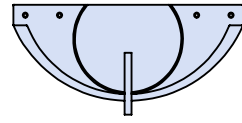
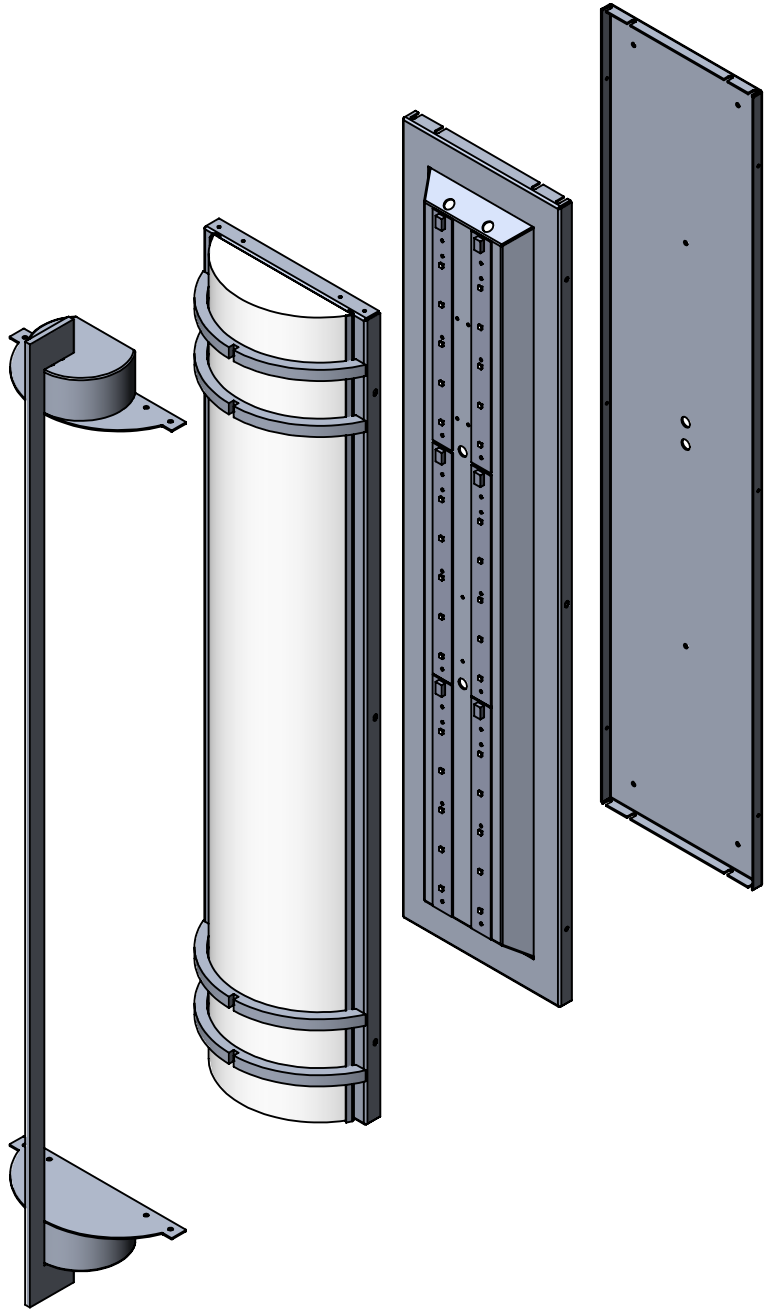

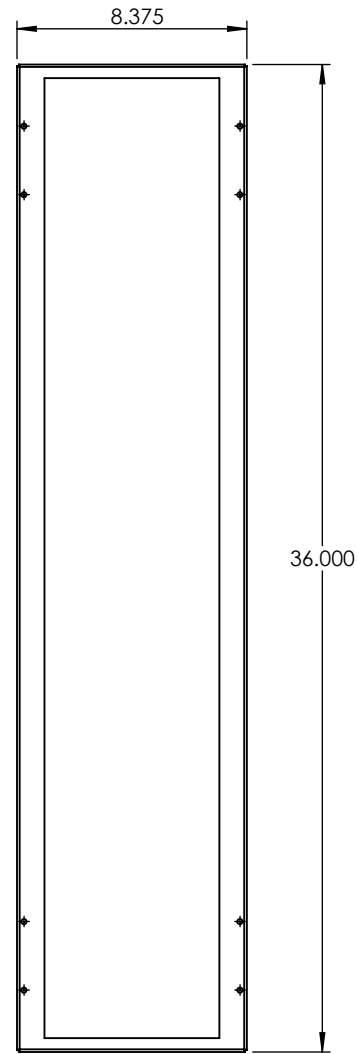
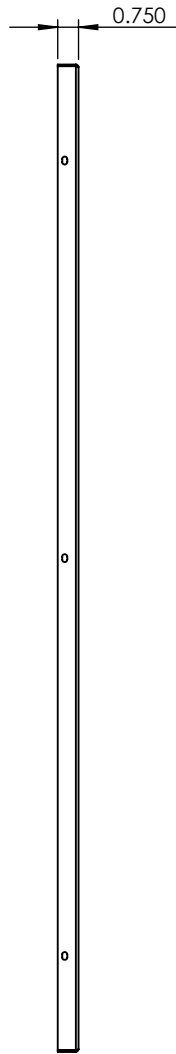
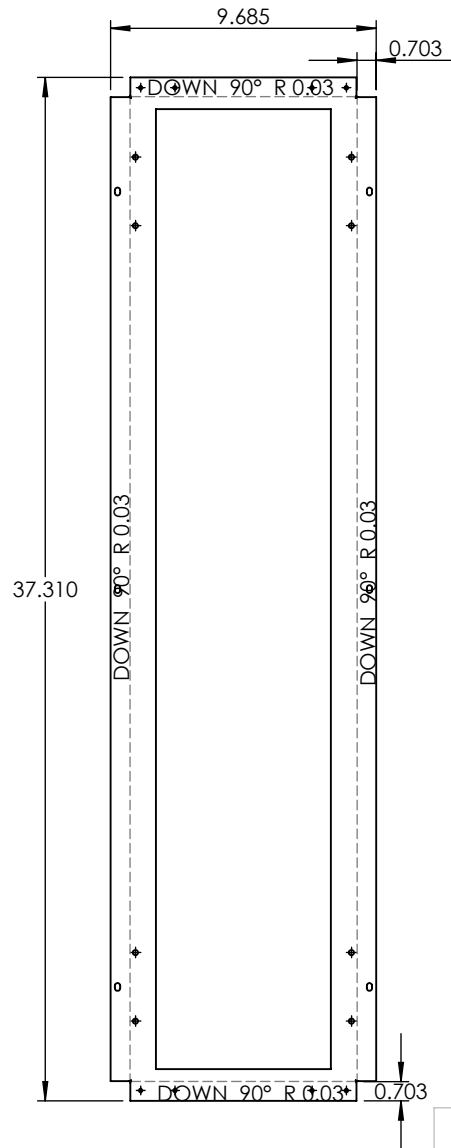

PROPRIETARY AND CONFIDENTIAL
 THE INFORMATION CONTAINED IN THIS DRAWING IS THE SOLE PROPERTY OF <INSERT COMPANY NAME HERE>. ANY REPRODUCTION IN PART OR AS A WHOLE WITHOUT THE WRITTEN PERMISSION OF <INSERT COMPANY NAME HERE> IS PROHIBITED.

		UNLESS OTHERWISE SPECIFIED:		NAME	DATE
		DIMENSIONS ARE IN INCHES	DRAWN		
		TOLERANCES:	CHECKED		
		FRACTIONAL ±	ENG APPR.		
		ANGULAR: MACH ± BEND ±	MFG APPR.		
		TWO PLACE DECIMAL ±	Q.A.		
		THREE PLACE DECIMAL ±	COMMENTS:		
		INTERPRET GEOMETRIC TOLERANCING PER:			
		MATERIAL			
	NEXT ASSY	USED ON			
		FINISH			
	APPLICATION	DO NOT SCALE DRAWING			

ALUMINUM 0.0635"

TITLE:
 SHWL-43-30W-MN-WF-STB-WET-41K

SIZE	DWG. NO.	REV
A		

SCALE: 1:7	WEIGHT:	SHEET 3 OF 11
------------	---------	---------------

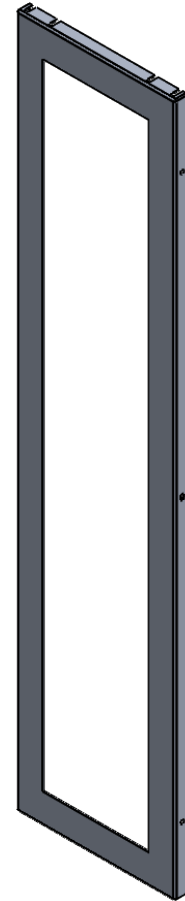
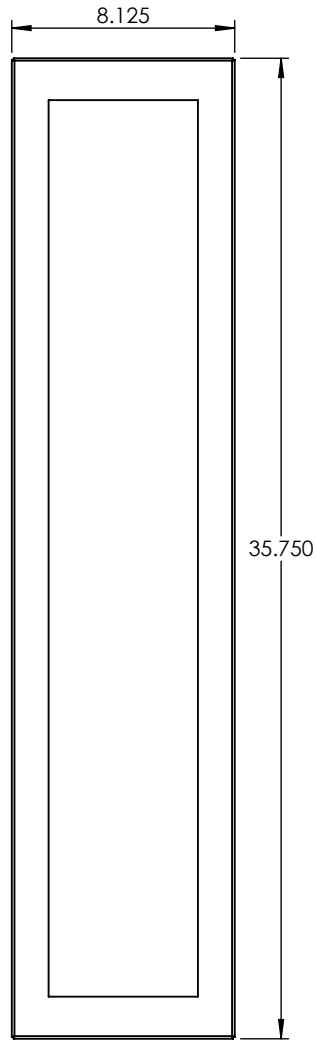
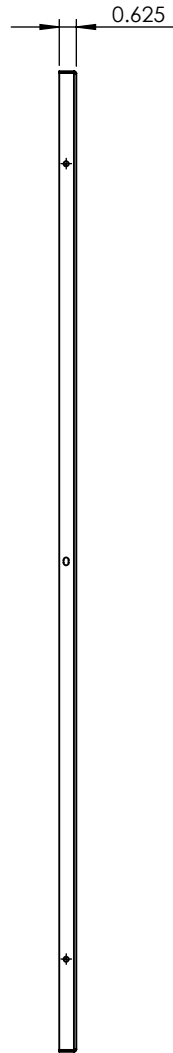
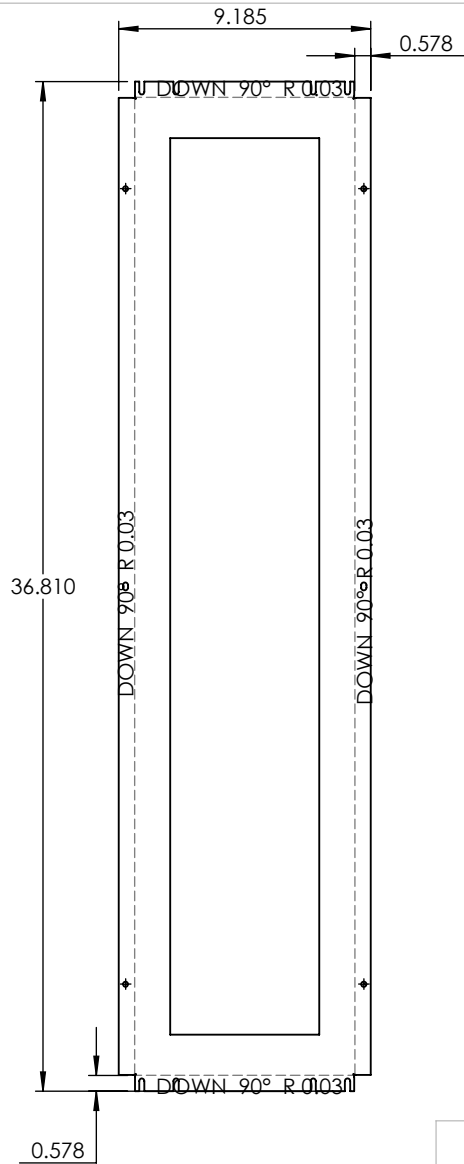

PROPRIETARY AND CONFIDENTIAL
 THE INFORMATION CONTAINED IN THIS DRAWING IS THE SOLE PROPERTY OF <INSERT COMPANY NAME HERE>. ANY REPRODUCTION IN PART OR AS A WHOLE WITHOUT THE WRITTEN PERMISSION OF <INSERT COMPANY NAME HERE> IS PROHIBITED.

		UNLESS OTHERWISE SPECIFIED:	NAME	DATE	ALUMINUM 0.0635"	
		DIMENSIONS ARE IN INCHES	DRAWN		TITLE:	
		TOLERANCES:	CHECKED		SHWL-43-30W-MN-WF-STB-WET-41K	
		FRACTIONAL ±	ENG APPR.		SIZE DWG. NO. REV	
		ANGULAR: MACH ± BEND ±	MFG APPR.		SCALE: 1:7 WEIGHT: SHEET 4 OF 11	
		TWO PLACE DECIMAL ±	Q.A.			
		THREE PLACE DECIMAL ±	COMMENTS:			
		INTERPRET GEOMETRIC TOLERANCING PER:				
		MATERIAL				
NEXT ASSY	USED ON	FINISH				
APPLICATION		DO NOT SCALE DRAWING				

5

4

3

2

1

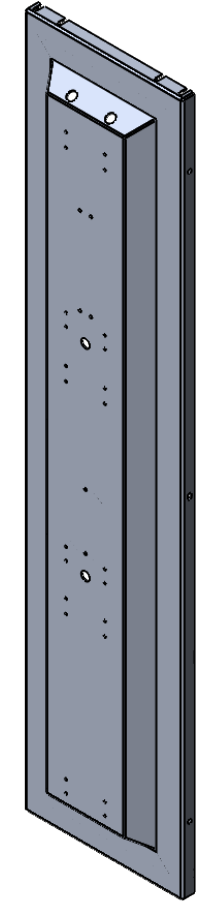
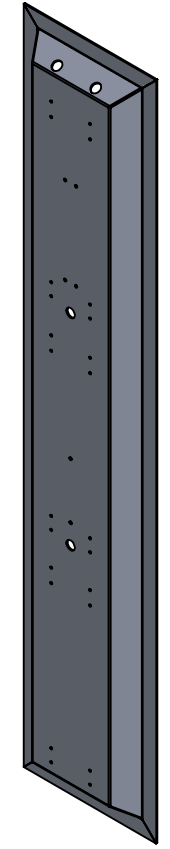
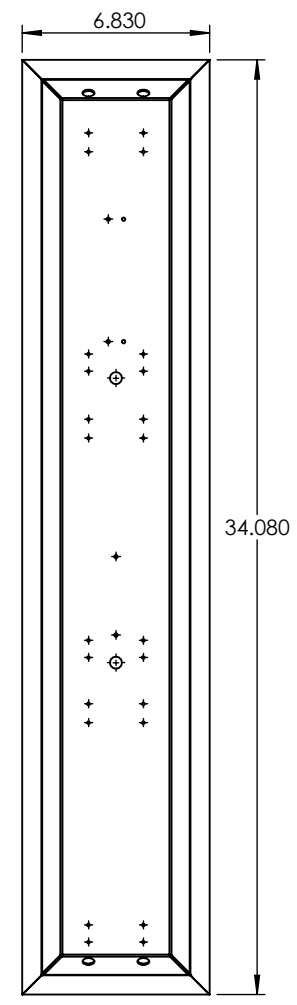
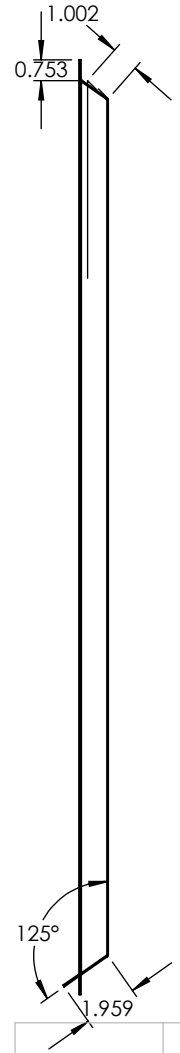
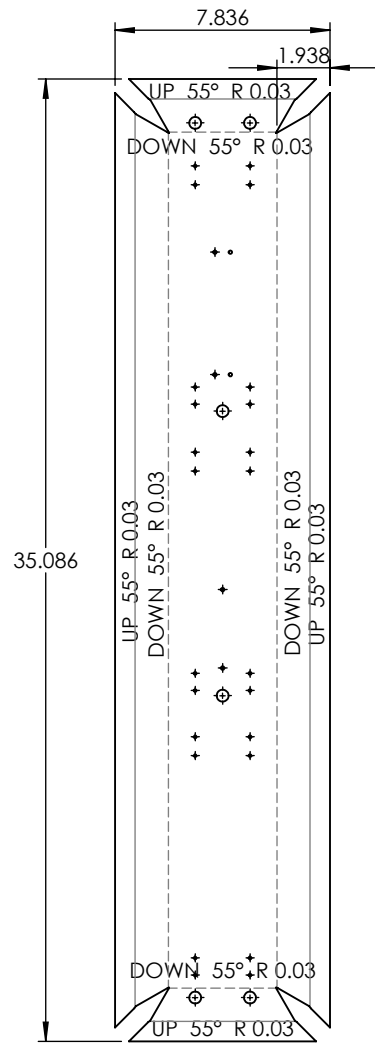

PROPRIETARY AND CONFIDENTIAL
 THE INFORMATION CONTAINED IN THIS DRAWING IS THE SOLE PROPERTY OF <INSERT COMPANY NAME HERE>. ANY REPRODUCTION IN PART OR AS A WHOLE WITHOUT THE WRITTEN PERMISSION OF <INSERT COMPANY NAME HERE> IS PROHIBITED.

		UNLESS OTHERWISE SPECIFIED:		NAME	DATE
		DIMENSIONS ARE IN INCHES	DRAWN		
		TOLERANCES:	CHECKED		
		FRACTIONAL ±	ENG APPR.		
		ANGULAR: MACH ± BEND ±	MFG APPR.		
		TWO PLACE DECIMAL ±	Q.A.		
		THREE PLACE DECIMAL ±	COMMENTS:		
		INTERPRET GEOMETRIC TOLERANCING PER:			
		MATERIAL			
NEXT ASSY	USED ON	FINISH			
APPLICATION		DO NOT SCALE DRAWING			

ALUMINUM 0.0635"		
TITLE:		
SHWL-43-30W-MN-WF-STB-WET-41K		
SIZE	DWG. NO.	REV
A		
SCALE: 1:7	WEIGHT:	SHEET 5 OF 11

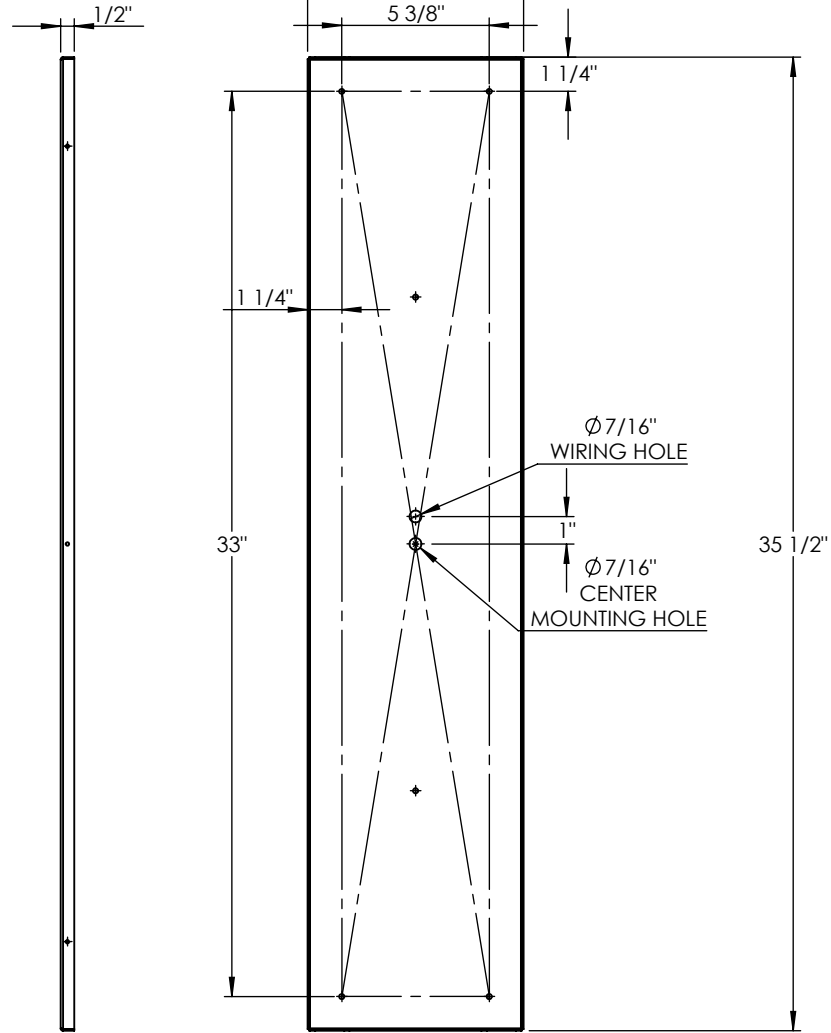
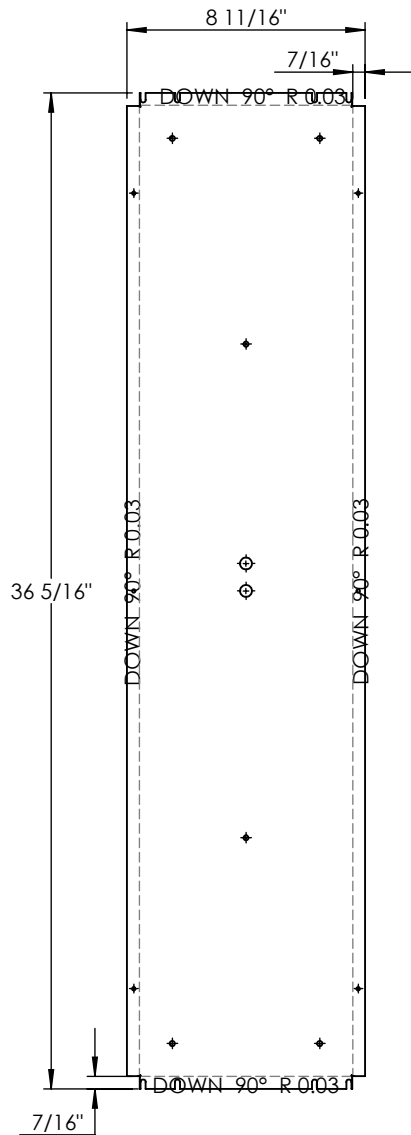

PROPRIETARY AND CONFIDENTIAL
 THE INFORMATION CONTAINED IN THIS DRAWING IS THE SOLE PROPERTY OF <INSERT COMPANY NAME HERE>. ANY REPRODUCTION IN PART OR AS A WHOLE WITHOUT THE WRITTEN PERMISSION OF <INSERT COMPANY NAME HERE> IS PROHIBITED.

		UNLESS OTHERWISE SPECIFIED:		NAME	DATE
		DIMENSIONS ARE IN INCHES TOLERANCES: FRACTIONAL ± ANGULAR: MACH ± BEND ± TWO PLACE DECIMAL ± THREE PLACE DECIMAL ±	DRAWN		
		INTERPRET GEOMETRIC TOLERANCING PER:	CHECKED		
		MATERIAL	ENG APPR.		
		FINISH	MFG APPR.		
NEXT ASSY	USED ON		Q.A.		
			COMMENTS:		
APPLICATION		DO NOT SCALE DRAWING			

ALUMINUM 0.0635"

TITLE:

SHWL-43-30W-MN-WF-STB-WET-41K

SIZE	DWG. NO.	REV
A		

SCALE: 1:7	WEIGHT:	SHEET 6 OF 11
------------	---------	---------------

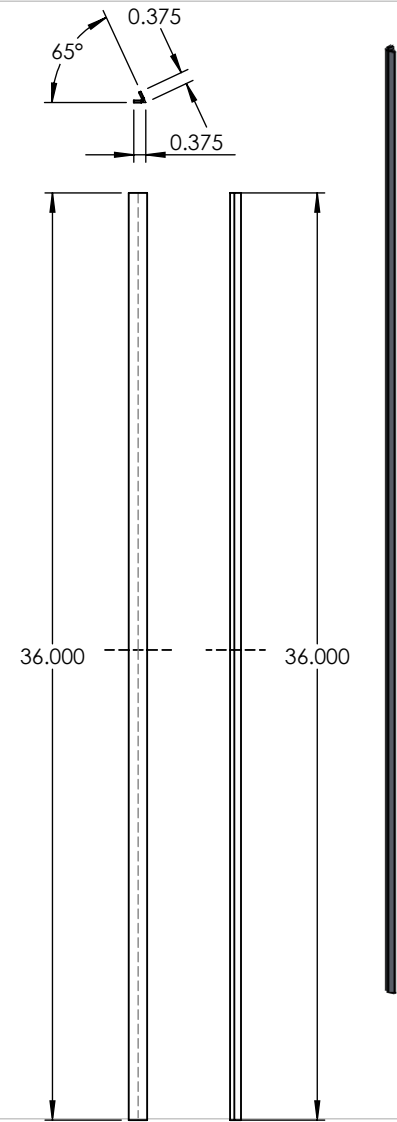
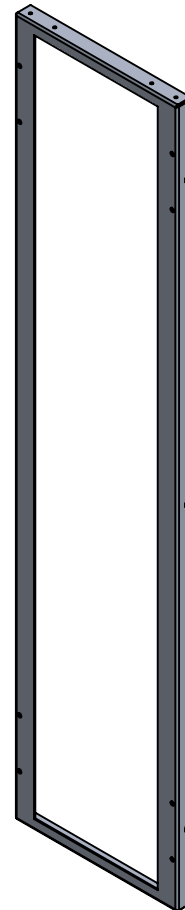
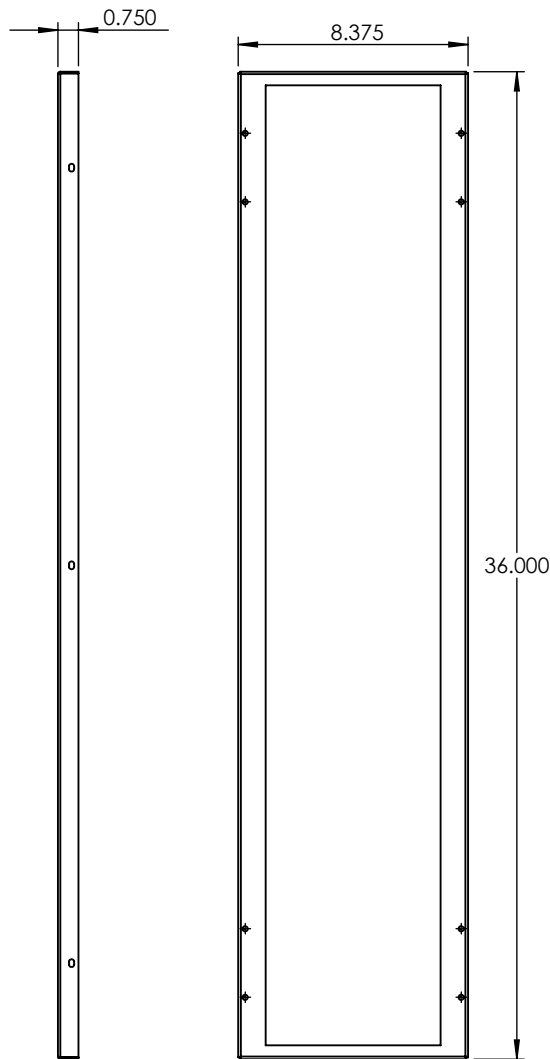
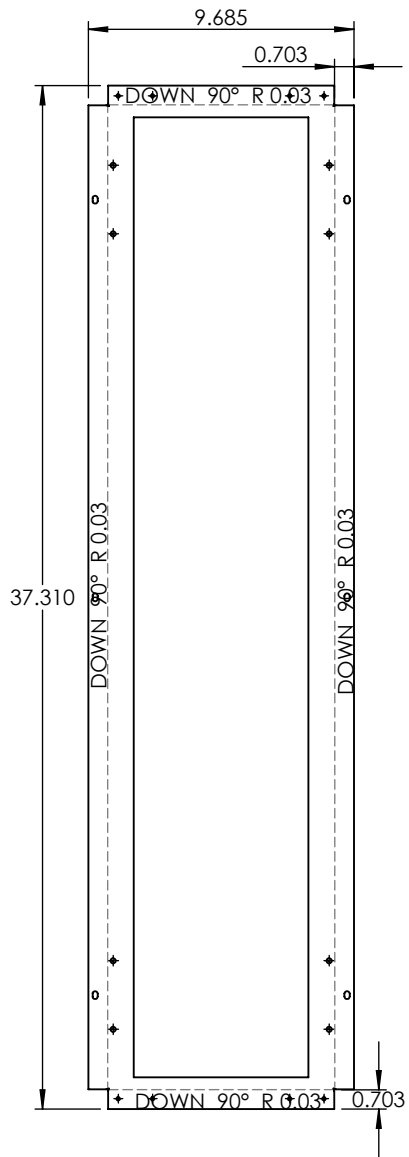

PROPRIETARY AND CONFIDENTIAL
 THE INFORMATION CONTAINED IN THIS DRAWING IS THE SOLE PROPERTY OF <INSERT COMPANY NAME HERE>. ANY REPRODUCTION IN PART OR AS A WHOLE WITHOUT THE WRITTEN PERMISSION OF <INSERT COMPANY NAME HERE> IS PROHIBITED.

		UNLESS OTHERWISE SPECIFIED:	NAME	DATE
		DIMENSIONS ARE IN INCHES	DRAWN	
		TOLERANCES:	CHECKED	
		FRACTIONAL ±	ENG APPR.	
		ANGULAR: MACH ± BEND ±	MFG APPR.	
		TWO PLACE DECIMAL ±	Q.A.	
		THREE PLACE DECIMAL ±	COMMENTS:	
		INTERPRET GEOMETRIC TOLERANCING PER:		
		MATERIAL		
NEXT ASSY	USED ON	FINISH		
APPLICATION		DO NOT SCALE DRAWING		

ALUMINUM 0.0635"		
TITLE:		
SHWL-43-30W-MN-WF-STB-WET-41K		
SIZE	DWG. NO.	REV
A		
SCALE: 1:7	WEIGHT:	SHEET 7 OF 11

5

4

3

2

1

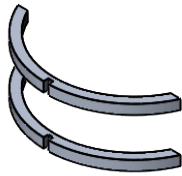
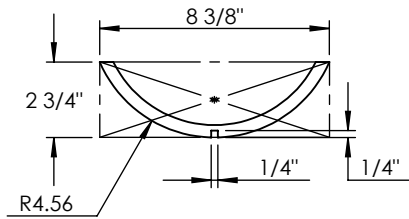

**HORIZONTAL BARS, LENS RAILS AND
FRAME WELDED AND BOLTED AS ONE**

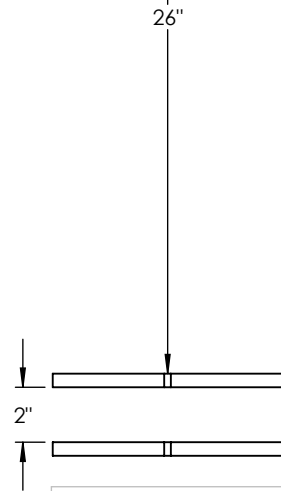
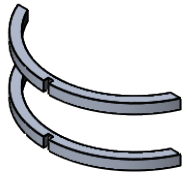
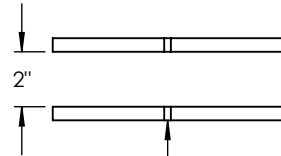

PROPRIETARY AND CONFIDENTIAL
THE INFORMATION CONTAINED IN THIS DRAWING IS THE SOLE PROPERTY OF <INSERT COMPANY NAME HERE>. ANY REPRODUCTION IN PART OR AS A WHOLE WITHOUT THE WRITTEN PERMISSION OF <INSERT COMPANY NAME HERE> IS PROHIBITED.

		UNLESS OTHERWISE SPECIFIED:		NAME	DATE	1/2" SQUARE ALUMINUM BAR
		DIMENSIONS ARE IN INCHES TOLERANCES: FRACTIONAL ± ANGULAR: MACH ± BEND ± TWO PLACE DECIMAL ± THREE PLACE DECIMAL ±	DRAWN			
		INTERPRET GEOMETRIC TOLERANCING PER:	CHECKED			SHWL-43-30W-MN-WF-STB-WET-41K
		MATERIAL	ENG APPR.			
NEXT ASSY	USED ON	FINISH	MFG APPR.			SCALE: 1:7 WEIGHT: SHEET 8 OF 11
APPLICATION		DO NOT SCALE DRAWING	Q.A.			
			COMMENTS:			

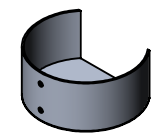
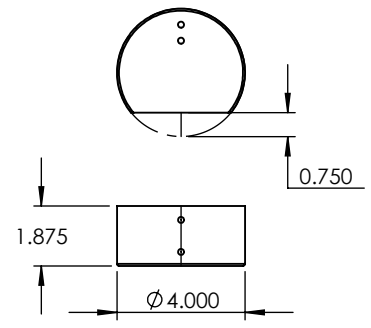
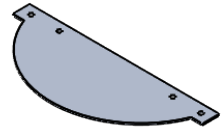
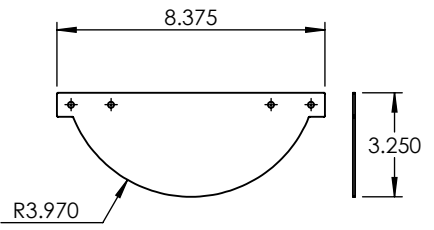
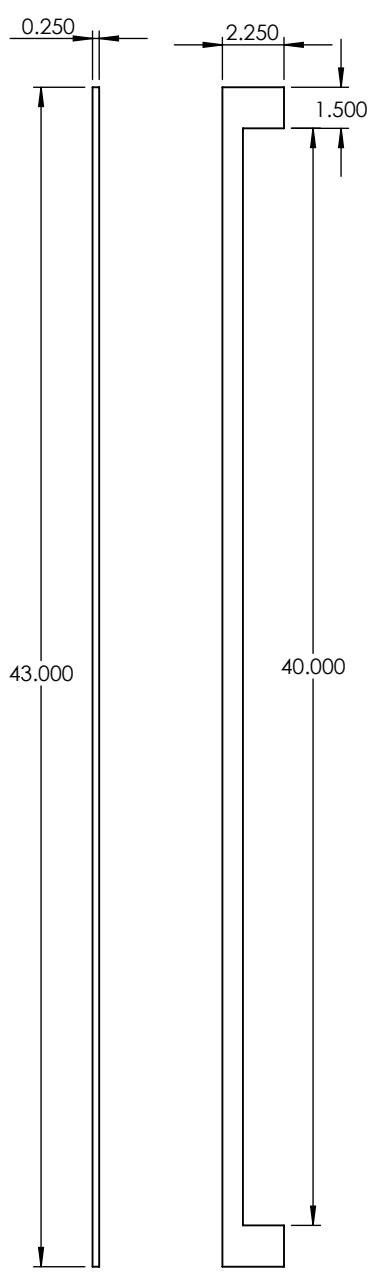

PROPRIETARY AND CONFIDENTIAL
 THE INFORMATION CONTAINED IN THIS DRAWING IS THE SOLE PROPERTY OF <INSERT COMPANY NAME HERE>. ANY REPRODUCTION IN PART OR AS A WHOLE WITHOUT THE WRITTEN PERMISSION OF <INSERT COMPANY NAME HERE> IS PROHIBITED.

		UNLESS OTHERWISE SPECIFIED:		NAME	DATE
		DIMENSIONS ARE IN INCHES	DRAWN		
		TOLERANCES:	CHECKED		
		FRACTIONAL ±	ENG APPR.		
		ANGULAR: MACH ± BEND ±	MFG APPR.		
		TWO PLACE DECIMAL ±	Q.A.		
		THREE PLACE DECIMAL ±	COMMENTS:		
		INTERPRET GEOMETRIC TOLERANCING PER:			
		MATERIAL			
NEXT ASSY	USED ON	FINISH			
APPLICATION		DO NOT SCALE DRAWING			

ALUMINUM 0.500" PLATE		
TITLE:		
SHWL-43-30W-MN-WF-STB-WET-41K		
SIZE	DWG. NO.	REV
A		
SCALE: 1:7	WEIGHT:	SHEET 9 OF 11

5

4

3

2

1

ITEM NO.	PART NUMBER	DESCRIPTION	QTY.
1	SHWL-43-30W-MN-WF-STB-WET-41K-SPUN CAP	ALUMINUM 0.0635"	1

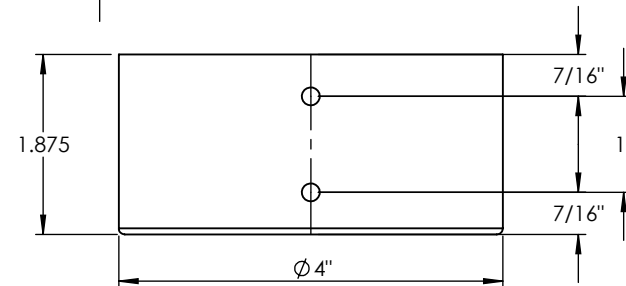
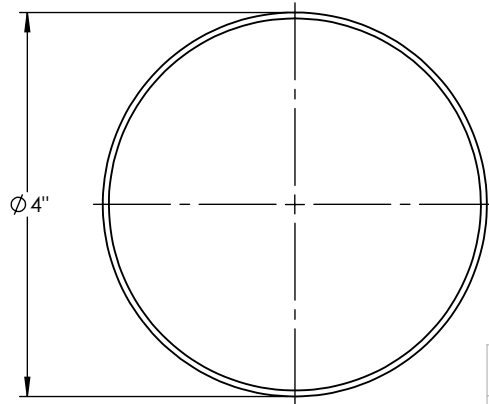
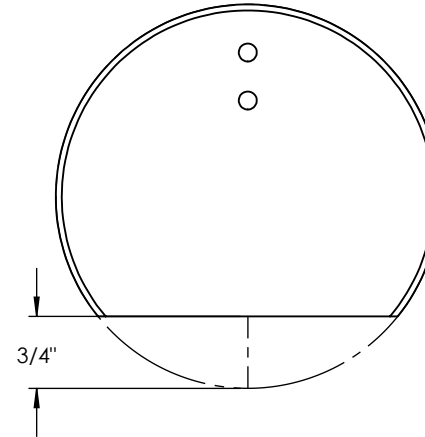
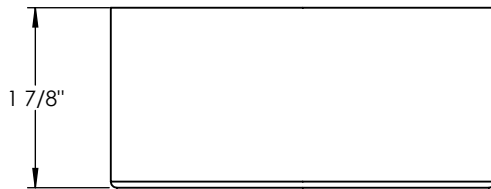
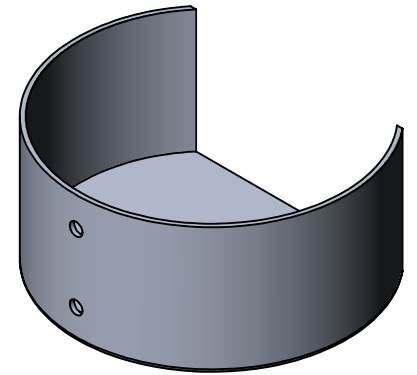
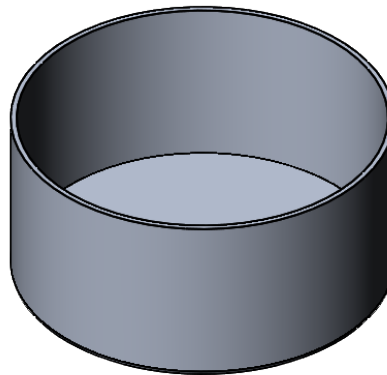
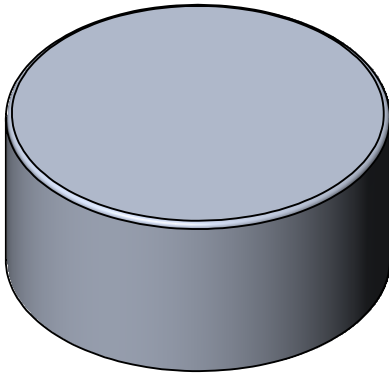

PROPRIETARY AND CONFIDENTIAL
 THE INFORMATION CONTAINED IN THIS DRAWING IS THE SOLE PROPERTY OF <INSERT COMPANY NAME HERE>. ANY REPRODUCTION IN PART OR AS A WHOLE WITHOUT THE WRITTEN PERMISSION OF <INSERT COMPANY NAME HERE> IS PROHIBITED.

		UNLESS OTHERWISE SPECIFIED:	NAME	DATE	ALUMINUM 0.0635"	
		DIMENSIONS ARE IN INCHES	DRAWN		TITLE:	
		TOLERANCES:	CHECKED		SHWL-43-30W-MN-WF-STB-WET-41K	
		FRACTIONAL ±	ENG APPR.		SIZE DWG. NO. REV	
		ANGULAR: MACH ± BEND ±	MFG APPR.		A	
		TWO PLACE DECIMAL ±	Q.A.		SCALE: 1:2 WEIGHT: SHEET 10 OF 11	
		THREE PLACE DECIMAL ±	COMMENTS:			
NEXT ASSY	USED ON	INTERPRET GEOMETRIC TOLERANCING PER:				
APPLICATION		MATERIAL				
		FINISH				
		DO NOT SCALE DRAWING				

5

4

3

2

1

