

UNLESS OTHERWISE SPECIFIED:		NAME	DATE		
DIMENSIONS ARE IN INCHES		DRAWN		TITLE:	
TOLERANCES:		CHECKED		BEL26"-6-PST-SHK-125W-TBK-CFA-40K-TP.	
FRACTIONAL ± .003		ENG APPR.		SIZE	DWG. NO.
ANGULAR: MACH ± .01 BEND ±		MFG APPR.		A	TICKET 25624
TWO PLACE DECIMAL ±		Q.A.		SCALE: 1:14	WEIGHT:
THREE PLACE DECIMAL ±.001		COMMENTS:		SHEET 1 OF 15	REV
INTERPRET GEOMETRIC TOLERANCING PER:					
MATERIAL					
FINISH					



ALL BEND RADIUS .030"

APPLICATION

DO NOT SCALE DRAWING

5

4

3

2

1

ITEM NO.	PART NUMBER	DESCRIPTION	QTY.	CUT
1	BEL26"-6-PST-SHK-125W-TBK-CFA-40K-TP3-BELL SKIRT HOUSING	SPUN ALUMINUM 0.080"	1	
2	BEL26"-6-PST-SHK-125W-TBK-CFA-40K-TP3-BELL HALF SPHERE	SPUN ALUMINUM 0.080"	1	
3	BEL26"-6-PST-SHK-125W-TBK-CFA-40K-TP3-SPUN DOOR	SPUN ALUMINUM 0.080"	1	
4	BEL26"-6-PST-SHK-125W-TBK-CFA-40K-TP3-SPUN DOOR BRACKET	SPUN ALUMINUM 0.080"	1	
5	BEL26"-6-PST-SHK-125W-TBK-CFA-40K-TP3-ARM CAP	SPUN ALUMINUM 0.080"	1	
6	BEL26"-6-PST-SHK-125W-TBK-CFA-40K-TP3-BELL LOUVER	SPUN ALUMINUM 0.0635"	2	
7	BEL26"-6-PST-SHK-125W-TBK-CFA-40K-TP3-ROUND LED PLATE	SPUN ALUMINUM 0.0635"	1	
8	BEL26"-6-PST-SHK-125W-TBK-CFA-40K-TP3-LED BRACKET	ALUMINUM 0.0635"	1	
9	BEL26"-6-PST-SHK-125W-TBK-CFA-40K-TP3-DRIVER BRACKET	ALUMINUM 0.0635"	1	
10	BEL26"-6-PST-SHK-125W-TBK-CFA-40K-TP3-2.000" CYLINDER CAP	ALUMINUM 0.250" PLATE	1	
11	BEL26"-6-PST-SHK-125W-TBK-CFA-40K-TP3-3.500" FITTER BRACKET	ALUMINUM 0.250" PLATE	1	
12	BEL26"-6-PST-SHK-125W-TBK-CFA-40K-TP3-PLATE SIDE	ALUMINUM 0.250" PLATE	2	
13	BEL26"-6-PST-SHK-125W-TBK-CFA-40K-TP3-3.000" CYLINDER	3" ALUMINUM TUBE POST	1	
14	BEL26"-6-PST-SHK-125W-TBK-CFA-40K-TP3-2.500" CYLINDER BRACKET	2 1/2" ALUMINUM TUBE	1	
15	BEL26"-6-PST-SHK-125W-TBK-CFA-40K-TP3-2.000" GOOSENECK FITTER	2" ALUMINUM TUBE	1	
16	BEL26"-6-PST-SHK-125W-TBK-CFA-40K-TP3-POST FITTER	3 1/2" ALUMINUM TUBE	1	
17	BEL26"-6-PST-SHK-125W-TBK-CFA-40K-TP3-0.500" ROUND BAR	1/2" ALUMINUM ROUND BAR	8	
18	BEL26"-6-PST-SHK-125W-TBK-CFA-40K-TP3-GOOSENECK TUBE	2" ALUMINUM TUBE	1	
19	BEL26"-6-PST-SHK-125W-TBK-CFA-40K-TP3-ACRYLIC	ACRYLIC	1	
20	Altal_LED_PN1019_SHIM PLATE	ALUMINUM 0.125" PLATE	12	
23	ESPEL VEL29070MVH-1	DRIVER	6	
24	Altal_LED_PN1019_RevC	LED	12	

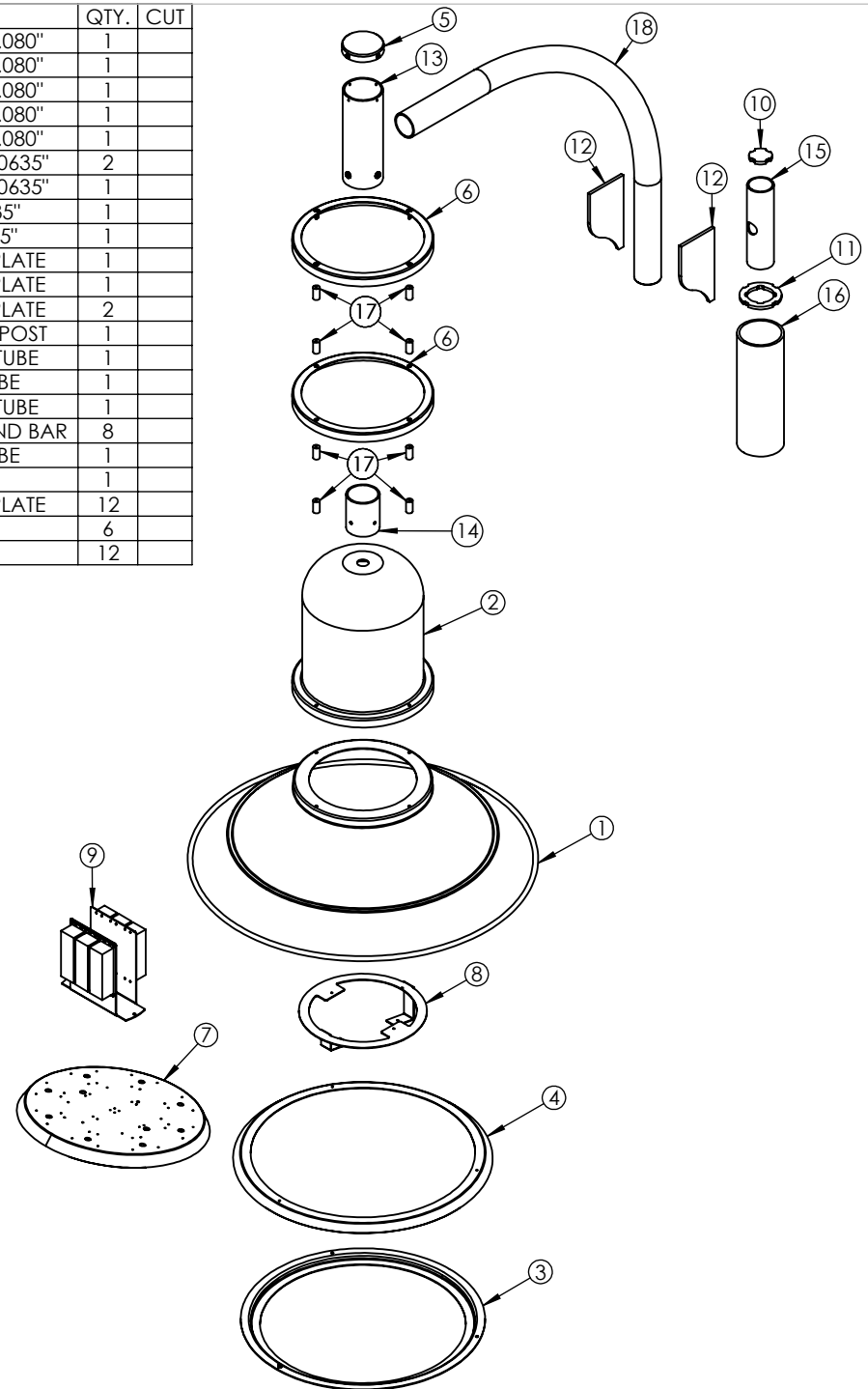

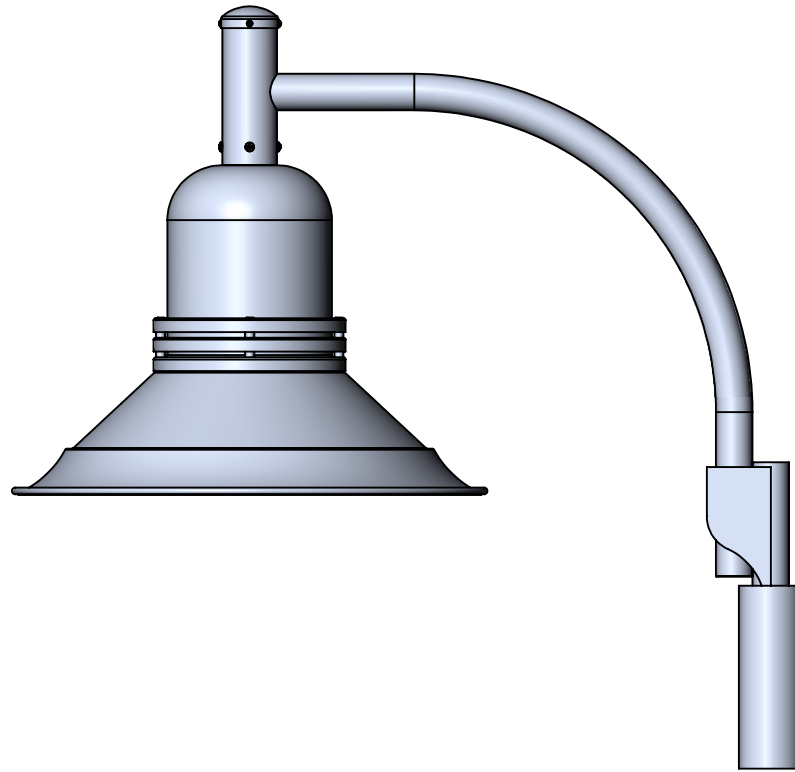
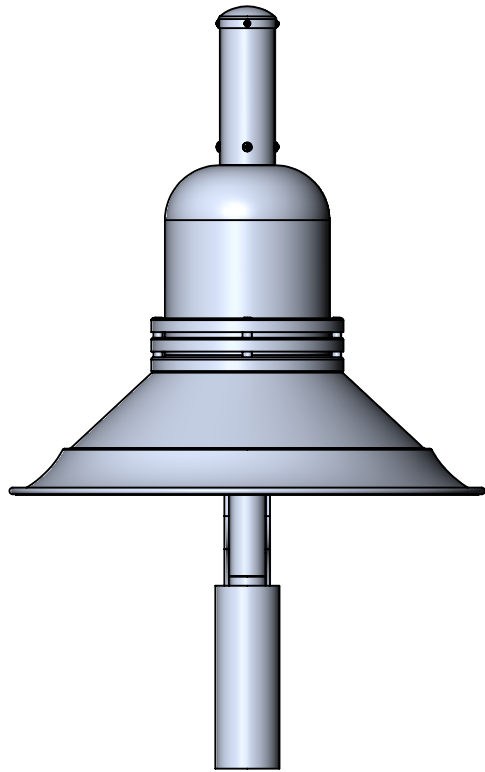
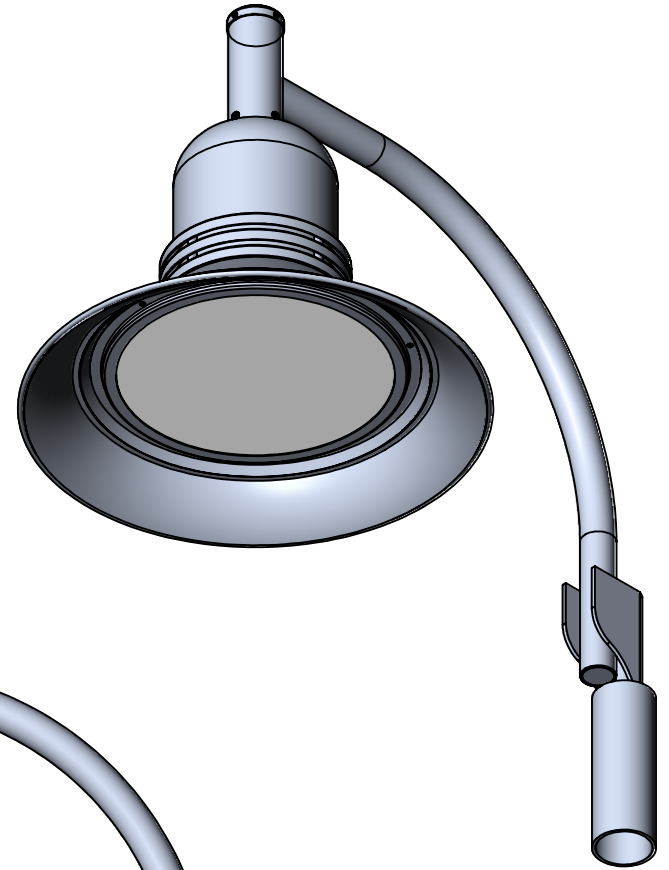
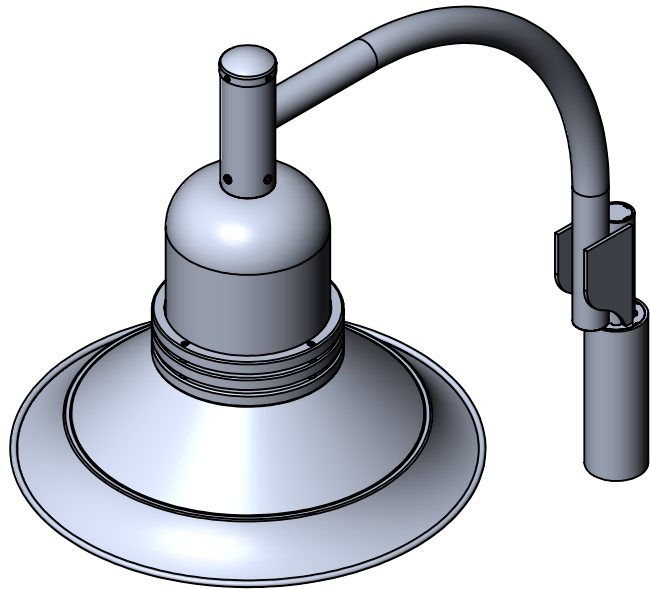

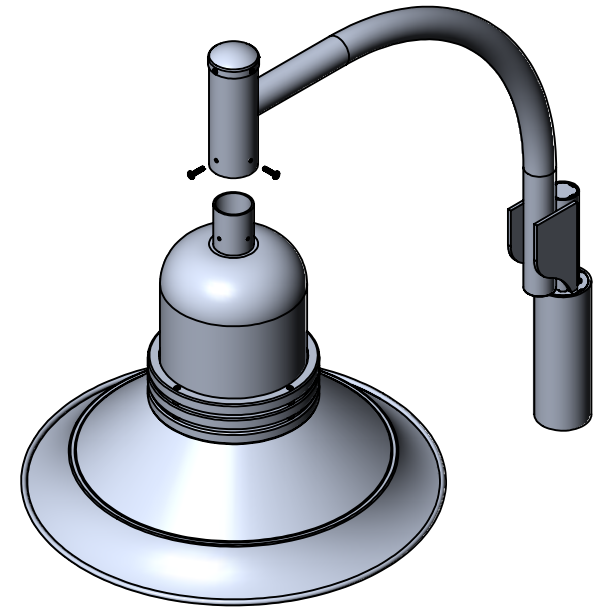
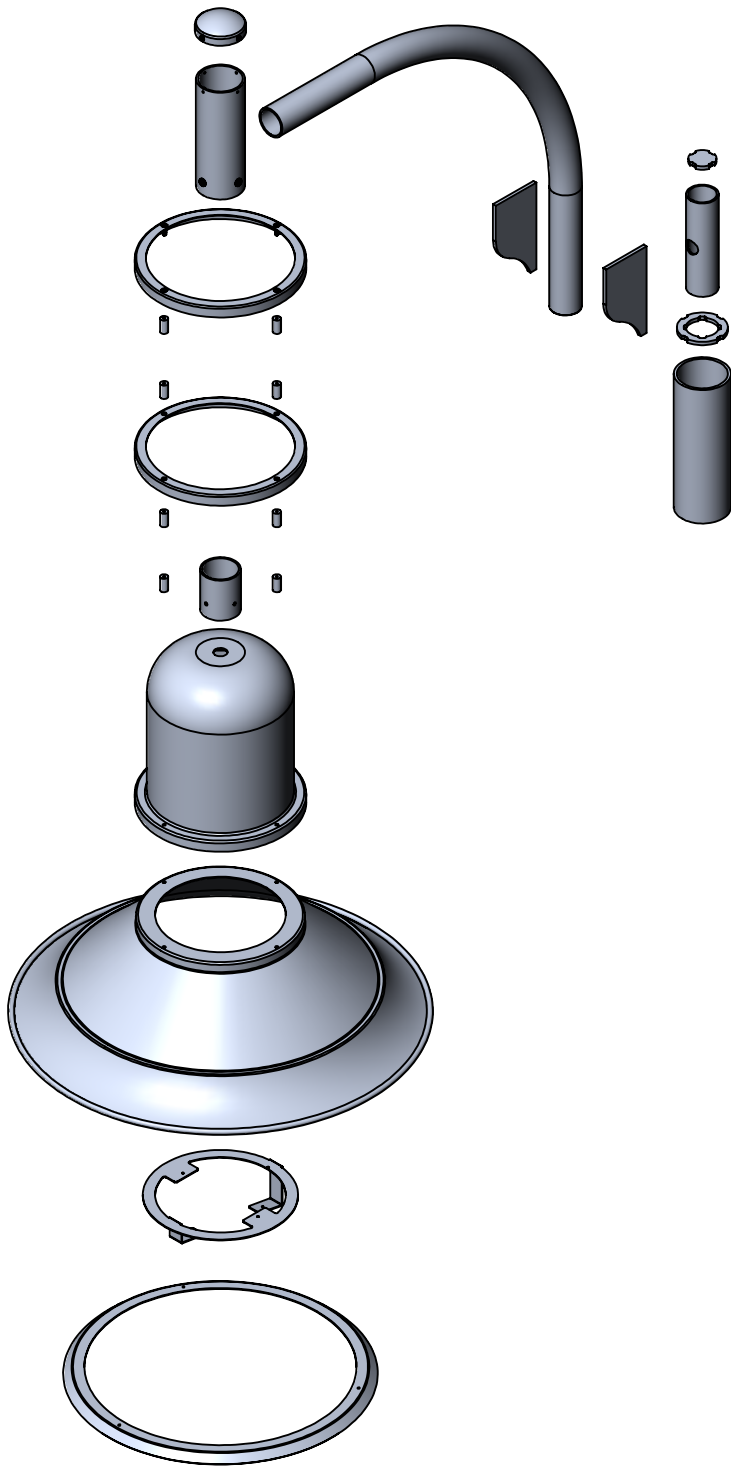

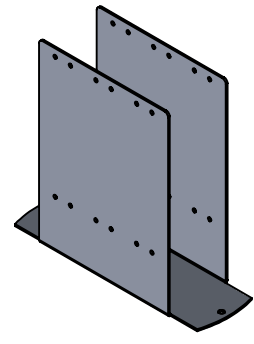
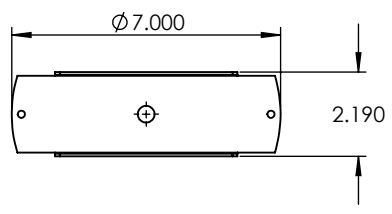
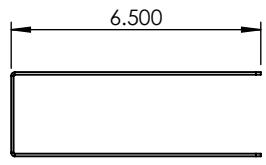
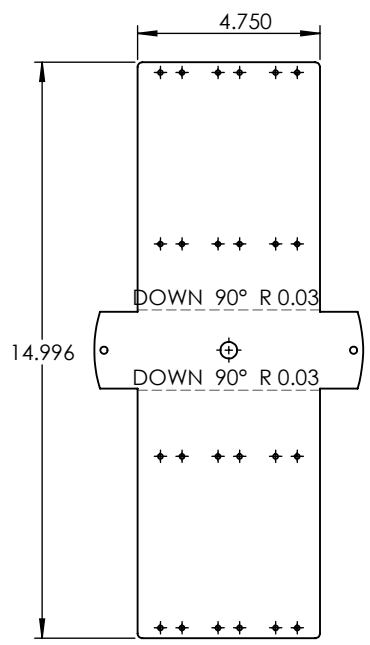
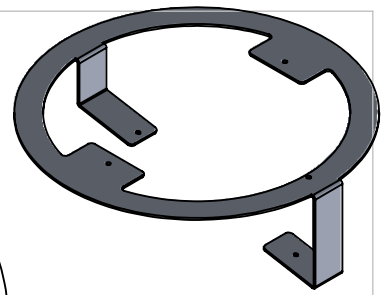
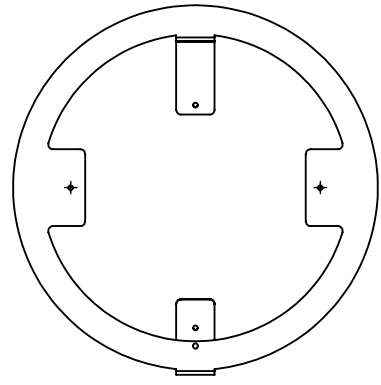
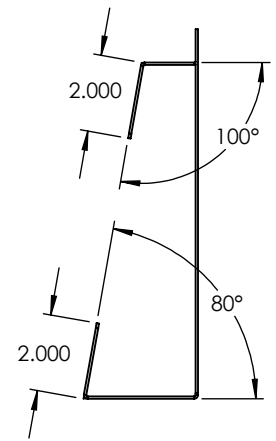
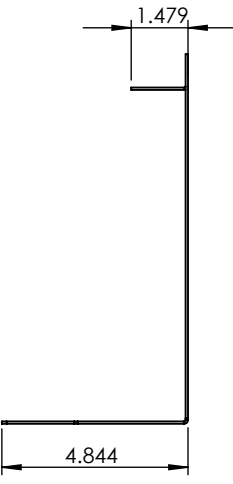
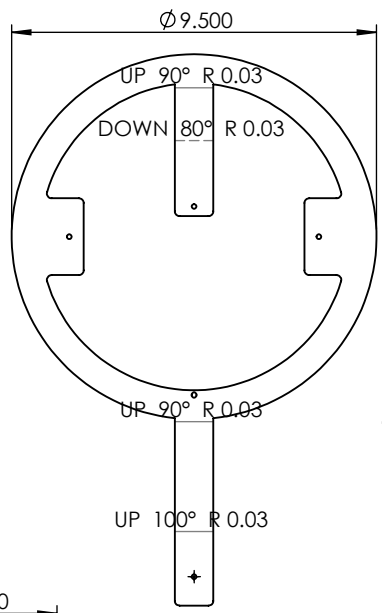

PROPRIETARY AND CONFIDENTIAL
 THE INFORMATION CONTAINED IN THIS DRAWING IS THE SOLE PROPERTY OF <INSERT COMPANY NAME HERE>. ANY REPRODUCTION IN PART OR AS A WHOLE WITHOUT THE WRITTEN PERMISSION OF <INSERT COMPANY NAME HERE> IS PROHIBITED.

		UNLESS OTHERWISE SPECIFIED:		NAME	DATE
		DIMENSIONS ARE IN INCHES	DRAWN		
		TOLERANCES:	CHECKED		
		FRACTIONAL ±	ENG APPR.		
		ANGULAR: MACH ± BEND ±	MFG APPR.		
		TWO PLACE DECIMAL ±	Q.A.		
		THREE PLACE DECIMAL ±	COMMENTS:		
		INTERPRET GEOMETRIC TOLERANCING PER:			
		MATERIAL			
		FINISH			
NEXT ASSY	USED ON				
APPLICATION	DO NOT SCALE DRAWING				

ALUMINUM 0.0635"		
TITLE:		
BEL26"-6-PST-SHK-125W-TBK-CFA-40K-TP3		
SIZE	DWG. NO.	REV
A		
SCALE: 1:5	WEIGHT:	SHEET 5 OF 15

5

4

3

2

1

ITEM NO.	PART NUMBER	DESCRIPTION	QTY.
1	BEL26"-6-PST-SHK-125W-TBK-CFA-40K-TP3-ROUND LED PLATE	ALUMINUM 0.0635	1

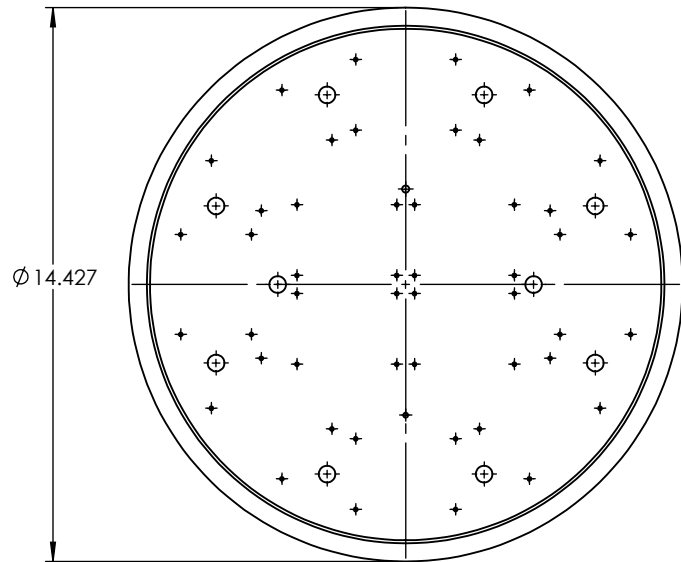
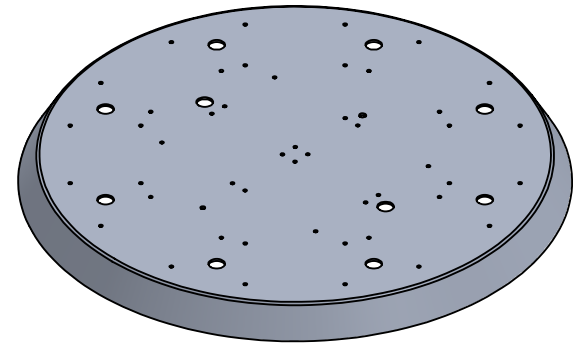
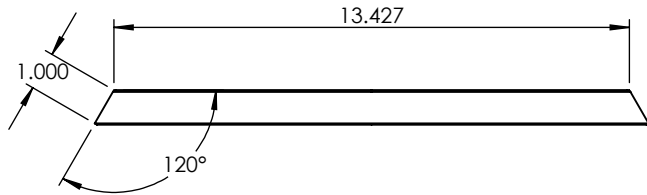

UNLESS OTHERWISE SPECIFIED:		NAME	DATE	ALUMINUM 0.0635		
DIMENSIONS ARE IN INCHES TOLERANCES: FRACTIONAL ± ANGULAR: MACH ± BEND ± TWO PLACE DECIMAL ± THREE PLACE DECIMAL ±		DRAWN				TITLE:
<p>PROPRIETARY AND CONFIDENTIAL THE INFORMATION CONTAINED IN THIS DRAWING IS THE SOLE PROPERTY OF <INSERT COMPANY NAME HERE>. ANY REPRODUCTION IN PART OR AS A WHOLE WITHOUT THE WRITTEN PERMISSION OF <INSERT COMPANY NAME HERE> IS PROHIBITED.</p>		CHECKED		BEL26"-6-PST-SHK-125W-TBK-CFA-40K-TP3		
		ENG APPR.				
		MFG APPR.				
INTERPRET GEOMETRIC TOLERANCING PER:		Q.A.		COMMENTS:		
MATERIAL				SIZE	DWG. NO.	REV
FINISH				A		
NEXT ASSY	USED ON			SCALE: 1:5	WEIGHT:	SHEET 6 OF 15
APPLICATION		DO NOT SCALE DRAWING				

5

4

3

2

1

ITEM NO.	PART NUMBER	DESCRIPTION	QTY.
1	BEL26"-6-PST-SHK-125W-BLK-CFA-40K-TP3-BELL HALF SPHERE	SPUN ALUMINUM 0.080"	1

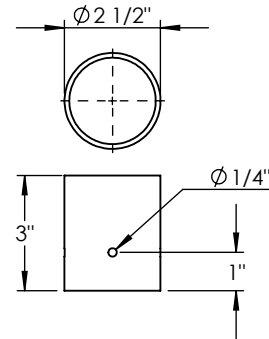
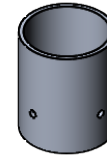
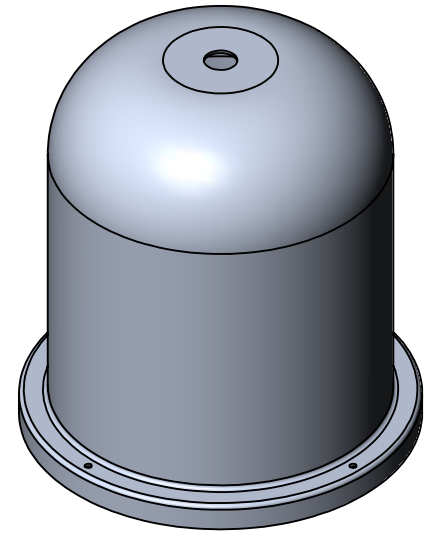
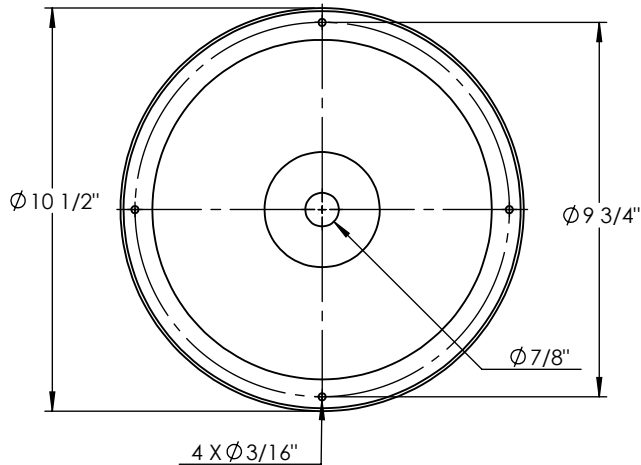
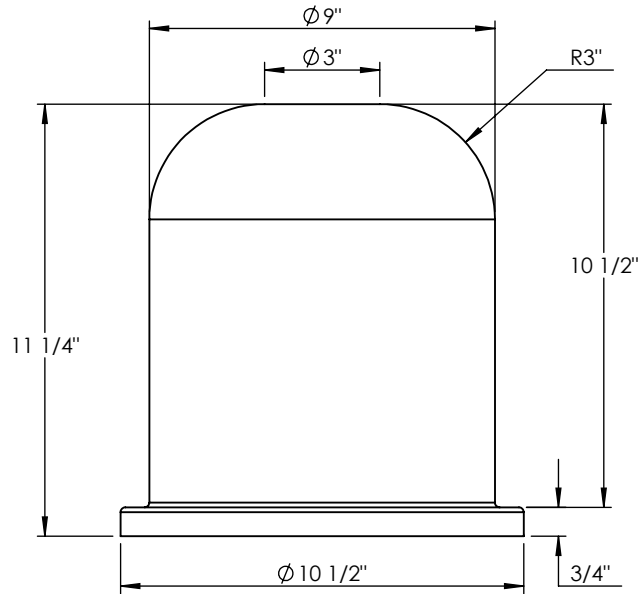

UNLESS OTHERWISE SPECIFIED:		NAME	DATE	SPUN ALUMINUM 0.080"	
DIMENSIONS ARE IN INCHES		DRAWN		TITLE:	
TOLERANCES:		CHECKED		BEL26"-6-PST-SHK-125W-TBK-CFA-40K-TP3	
FRACTIONAL ±		ENG APPR.		SIZE	DWG. NO.
ANGULAR: MACH ± BEND ±		MFG APPR.		A	
TWO PLACE DECIMAL ±		Q.A.		SCALE: 1:5	WEIGHT:
THREE PLACE DECIMAL ±		COMMENTS:			SHEET 7 OF 15
INTERPRET GEOMETRIC TOLERANCING PER:					
MATERIAL					
FINISH					
NEXT ASSY	USED ON				
APPLICATION					
DO NOT SCALE DRAWING					

PROPRIETARY AND CONFIDENTIAL
 THE INFORMATION CONTAINED IN THIS DRAWING IS THE SOLE PROPERTY OF <INSERT COMPANY NAME HERE>. ANY REPRODUCTION IN PART OR AS A WHOLE WITHOUT THE WRITTEN PERMISSION OF <INSERT COMPANY NAME HERE> IS PROHIBITED.

ITEM NO.	PART NUMBER	DESCRIPTION	QTY.
1	BEL26"-6-PST-SHK-125W-TBK-CFA-40K-TP3-BELL SKIRT HOUSING	SPUN ALUMINUM 0.080"	1

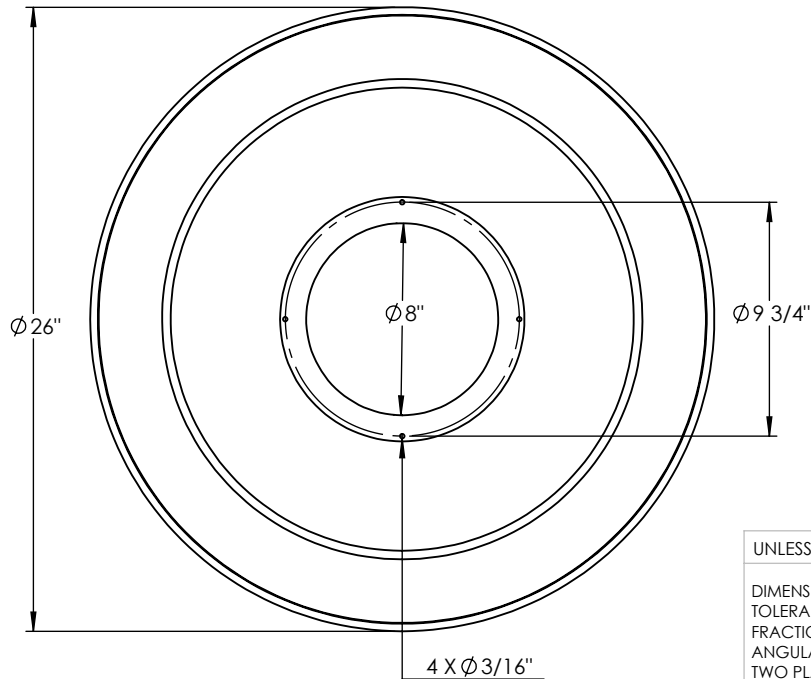
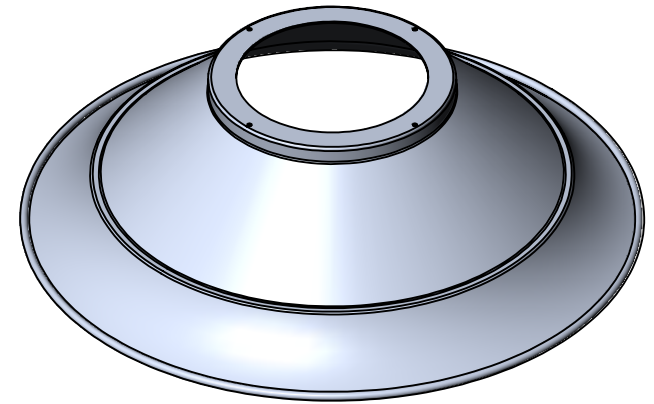
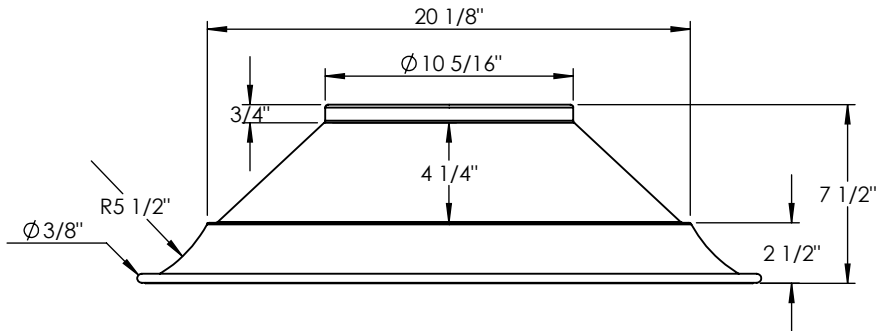

UNLESS OTHERWISE SPECIFIED:		NAME	DATE	SPUN ALUMINUM 0.080"	
DIMENSIONS ARE IN INCHES		DRAWN		TITLE:	
TOLERANCES:		CHECKED		BEL26"-6-PST-SHK-125W-TBK-CFA-40K-TP3	
FRACTIONAL ±		ENG APPR.		SIZE	DWG. NO.
ANGULAR: MACH ± BEND ±		MFG APPR.		A	REV
TWO PLACE DECIMAL ±		Q.A.		SCALE: 1:8	WEIGHT:
THREE PLACE DECIMAL ±		COMMENTS:			SHEET 8 OF 15
INTERPRET GEOMETRIC TOLERANCING PER:					
MATERIAL					
FINISH					
NEXT ASSY	USED ON				
APPLICATION					
DO NOT SCALE DRAWING					

PROPRIETARY AND CONFIDENTIAL
 THE INFORMATION CONTAINED IN THIS DRAWING IS THE SOLE PROPERTY OF <INSERT COMPANY NAME HERE>. ANY REPRODUCTION IN PART OR AS A WHOLE WITHOUT THE WRITTEN PERMISSION OF <INSERT COMPANY NAME HERE> IS PROHIBITED.

ITEM NO.	PART NUMBER	DESCRIPTION	QTY.
1	BEL26"-6-PST-SHK-125W-TBK-CFA-40K-TP3-BELL LOUVER	SPUN ALUMINUM 0.0635"	1

ITEM NO.	PART NUMBER	DESCRIPTION	QTY.
1	BEL26"-6-PST-SHK-125W-TBK-CFA-40K-TP3-ARM CAP	SPUN ALUMINUM 0.080"	1

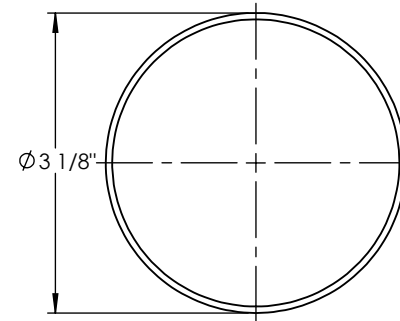
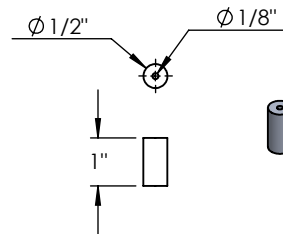
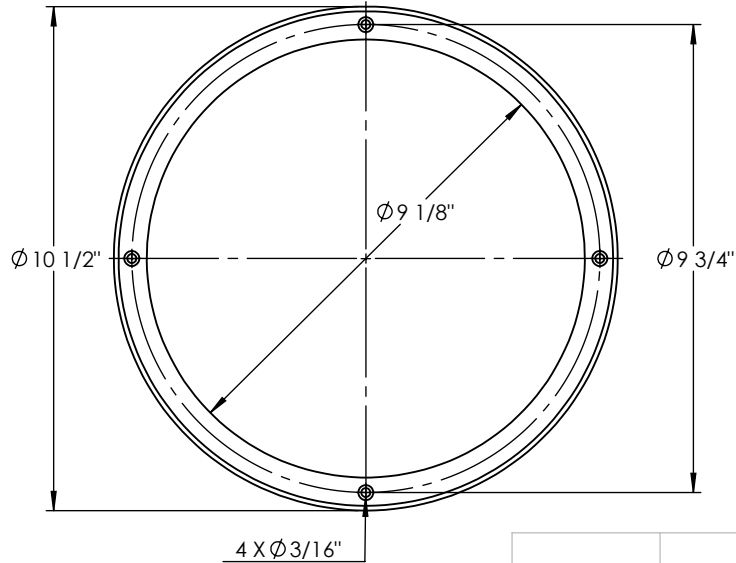
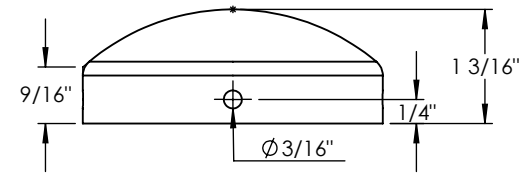
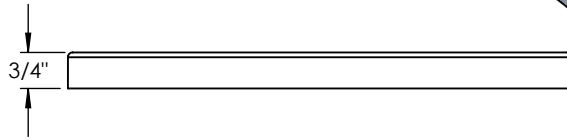
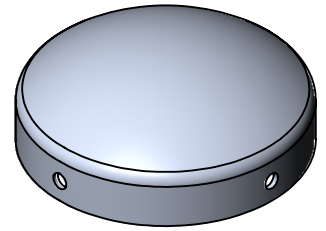
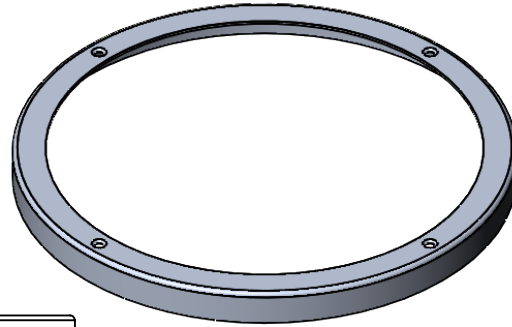

PROPRIETARY AND CONFIDENTIAL
 THE INFORMATION CONTAINED IN THIS DRAWING IS THE SOLE PROPERTY OF <INSERT COMPANY NAME HERE>. ANY REPRODUCTION IN PART OR AS A WHOLE WITHOUT THE WRITTEN PERMISSION OF <INSERT COMPANY NAME HERE> IS PROHIBITED.

		UNLESS OTHERWISE SPECIFIED:	NAME	DATE	SPUN ALUMINUM 0.0635"	
		DIMENSIONS ARE IN INCHES	DRAWN		TITLE:	
		TOLERANCES:	CHECKED		BEL26"-6-PST-SHK-125W-TBK-CFA-40K-TP3	
		FRACTIONAL ±	ENG APPR.		SIZE DWG. NO. REV	
		ANGULAR: MACH ± BEND ±	MFG APPR.		A	
		TWO PLACE DECIMAL ±	Q.A.		SCALE: 1:4 WEIGHT: SHEET 9 OF 15	
		THREE PLACE DECIMAL ±	COMMENTS:			
	INTERPRET GEOMETRIC TOLERANCING PER:	MATERIAL				
	MATERIAL	FINISH				
NEXT ASSY	USED ON					
APPLICATION	DO NOT SCALE DRAWING					

ITEM NO.	PART NUMBER	DESCRIPTION	QTY.
1	BEL26"-6-PST-SHK-125W-TBK-CFA-40K-TP3-SPUN DOOR BRACKET	SPUN ALUMINUM 0.080"	1

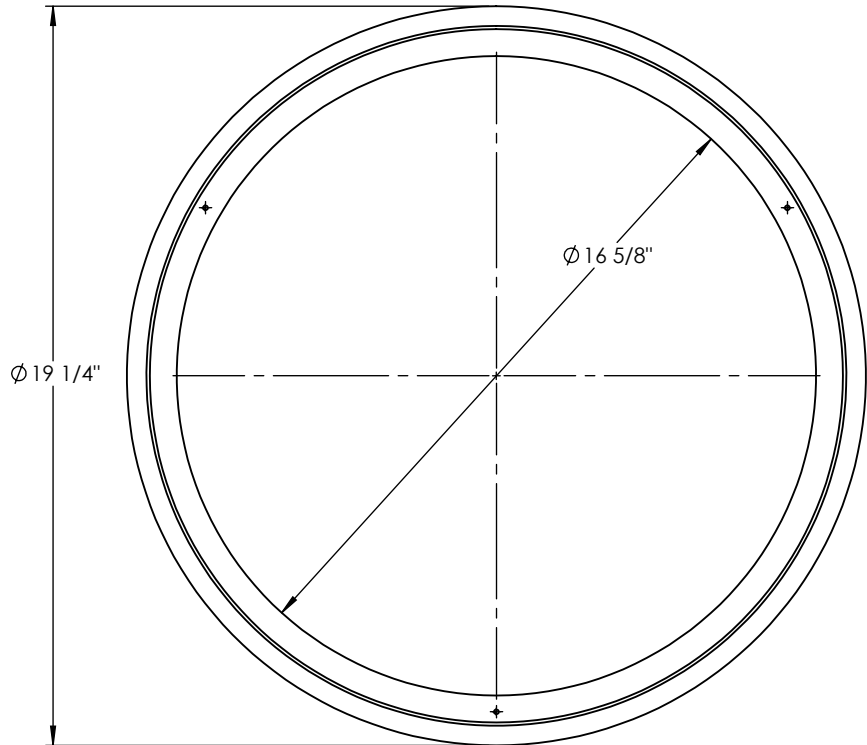
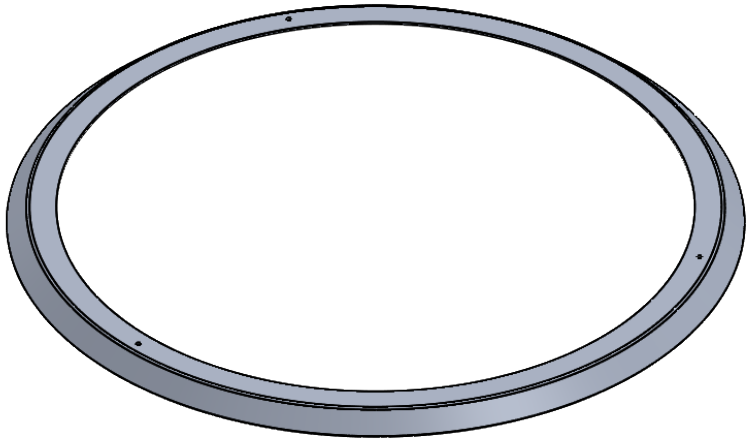
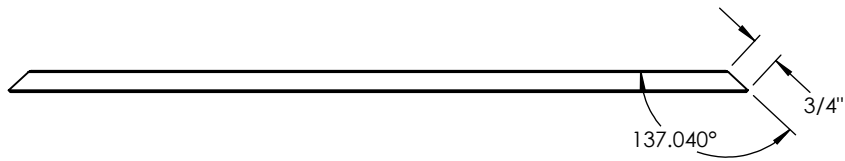

PROPRIETARY AND CONFIDENTIAL
 THE INFORMATION CONTAINED IN THIS DRAWING IS THE SOLE PROPERTY OF <INSERT COMPANY NAME HERE>. ANY REPRODUCTION IN PART OR AS A WHOLE WITHOUT THE WRITTEN PERMISSION OF <INSERT COMPANY NAME HERE> IS PROHIBITED.

		UNLESS OTHERWISE SPECIFIED:		NAME	DATE
		DIMENSIONS ARE IN INCHES	DRAWN		
		TOLERANCES:	CHECKED		
		FRACTIONAL ±	ENG APPR.		
		ANGULAR: MACH ± BEND ±	MFG APPR.		
		TWO PLACE DECIMAL ±	Q.A.		
		THREE PLACE DECIMAL ±	COMMENTS:		
		INTERPRET GEOMETRIC TOLERANCING PER:			
		MATERIAL			
		FINISH			
NEXT ASSY	USED ON				
APPLICATION		DO NOT SCALE DRAWING			

SPUN ALUMINUM 0.080"		
TITLE:		
BEL26"-6-PST-SHK-125W-TBK-CFA-40K-TP3		
SIZE	DWG. NO.	REV
A		
SCALE: 1:5	WEIGHT:	SHEET 10 OF 15

ITEM NO.	PART NUMBER	DESCRIPTION	QTY.
1	BEL26"-6-PST-SHK-125W-TBK-CFA-40K-TP3-SPUN DOOR	SPUN ALUMINUM 0.080"	1

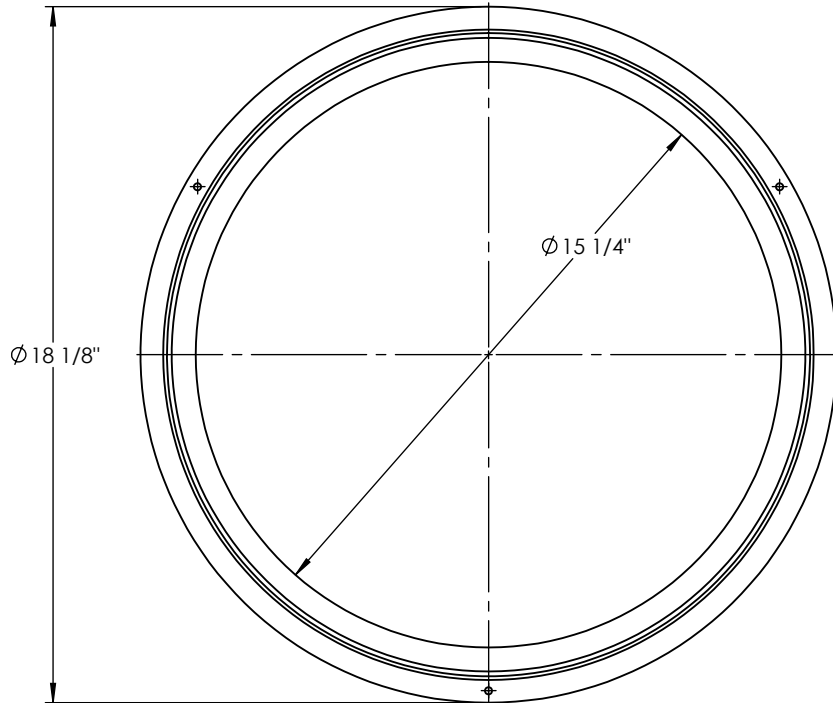

PROPRIETARY AND CONFIDENTIAL
 THE INFORMATION CONTAINED IN THIS DRAWING IS THE SOLE PROPERTY OF <INSERT COMPANY NAME HERE>. ANY REPRODUCTION IN PART OR AS A WHOLE WITHOUT THE WRITTEN PERMISSION OF <INSERT COMPANY NAME HERE> IS PROHIBITED.

		UNLESS OTHERWISE SPECIFIED:	NAME	DATE	SPUN ALUMINUM 0.080"	
		DIMENSIONS ARE IN INCHES	DRAWN		TITLE:	
		TOLERANCES:	CHECKED		BEL26"-6-PST-SHK-125W-TBK-CFA-40K-TP3	
		FRACTIONAL ±	ENG APPR.		SIZE DWG. NO. REV	
		ANGULAR: MACH ± BEND ±	MFG APPR.		A	
		TWO PLACE DECIMAL ±	Q.A.		SCALE: 1:5 WEIGHT: SHEET 11 OF 15	
		THREE PLACE DECIMAL ±	COMMENTS:			
		INTERPRET GEOMETRIC TOLERANCING PER:				
		MATERIAL				
NEXT ASSY	USED ON	FINISH				
APPLICATION		DO NOT SCALE DRAWING				

TOTAL LENGTH 44.5 INCHES

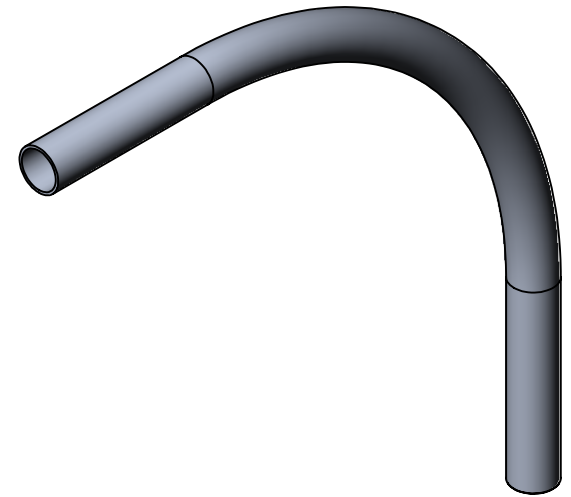
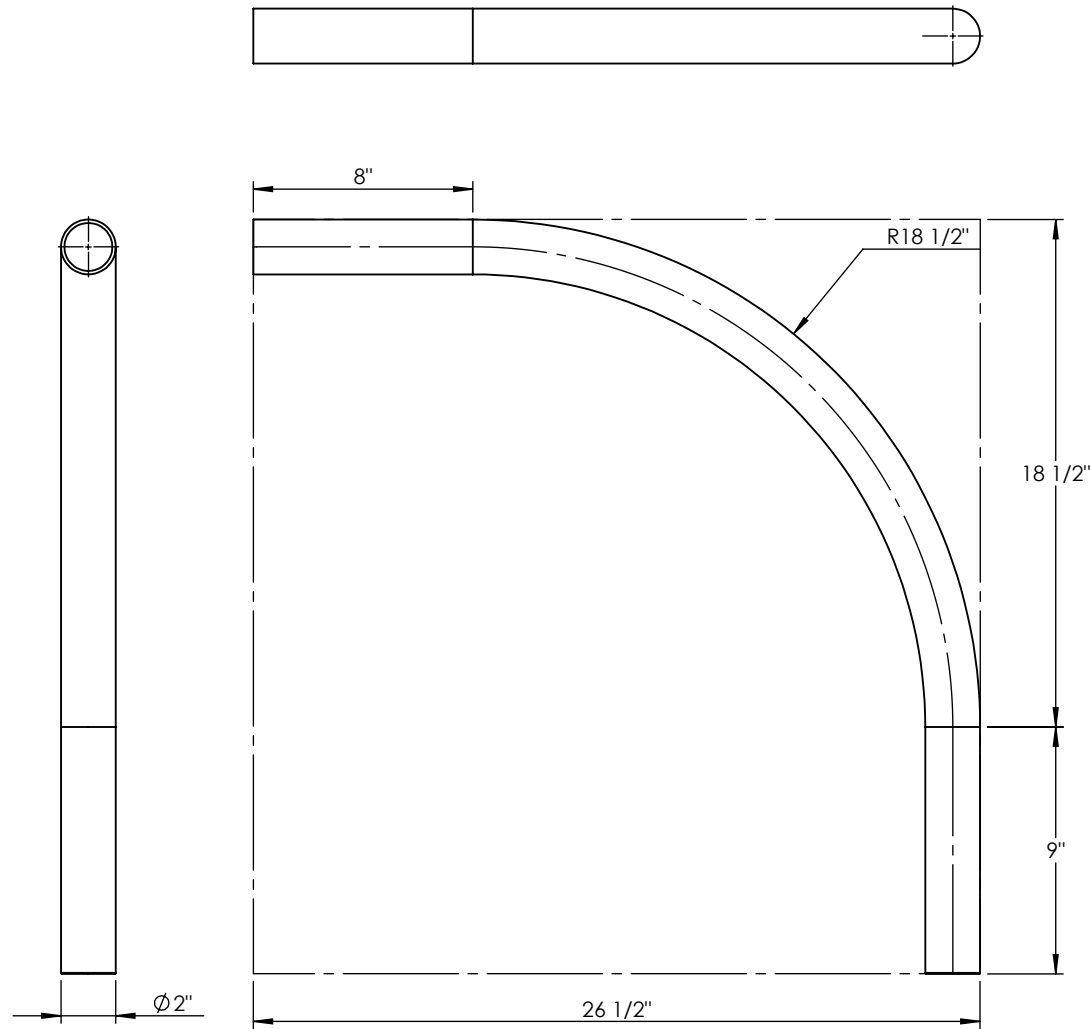

PROPRIETARY AND CONFIDENTIAL
 THE INFORMATION CONTAINED IN THIS DRAWING IS THE SOLE PROPERTY OF <INSERT COMPANY NAME HERE>. ANY REPRODUCTION IN PART OR AS A WHOLE WITHOUT THE WRITTEN PERMISSION OF <INSERT COMPANY NAME HERE> IS PROHIBITED.

		UNLESS OTHERWISE SPECIFIED:		NAME	DATE
		DIMENSIONS ARE IN INCHES	DRAWN		
		TOLERANCES:	CHECKED		
		FRACTIONAL ±	ENG APPR.		
		ANGULAR: MACH ± BEND ±	MFG APPR.		
TWO PLACE DECIMAL ±	Q.A.				
THREE PLACE DECIMAL ±	COMMENTS:				
INTERPRET GEOMETRIC TOLERANCING PER:					
MATERIAL					
FINISH					
APPLICATION	DO NOT SCALE DRAWING				

2" ALUMINUM TUBE

TITLE:
BEL26"-6-PST-SHK-125W-TBK-CFA-40K-TP3

SIZE	DWG. NO.	REV
A		

SCALE: 1:7 WEIGHT: SHEET 12 OF 15

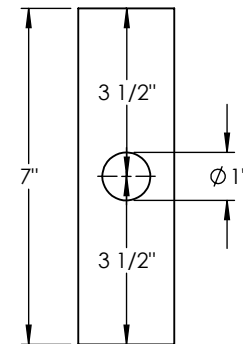
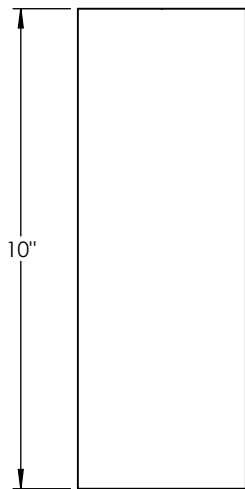
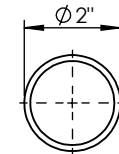
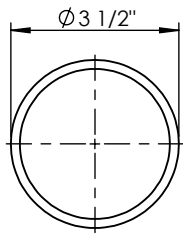
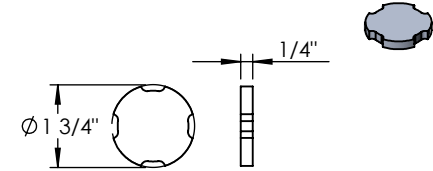
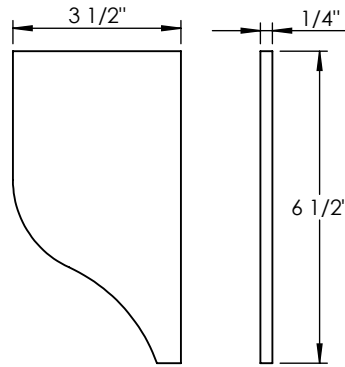
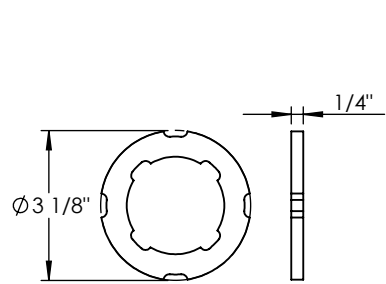

PROPRIETARY AND CONFIDENTIAL
 THE INFORMATION CONTAINED IN THIS DRAWING IS THE SOLE PROPERTY OF <INSERT COMPANY NAME HERE>. ANY REPRODUCTION IN PART OR AS A WHOLE WITHOUT THE WRITTEN PERMISSION OF <INSERT COMPANY NAME HERE> IS PROHIBITED.

		UNLESS OTHERWISE SPECIFIED:	NAME	DATE
		DIMENSIONS ARE IN INCHES	DRAWN	
		TOLERANCES:	CHECKED	
		FRACTIONAL ±	ENG APPR.	
		ANGULAR: MACH ± BEND ±	MFG APPR.	
		TWO PLACE DECIMAL ±	Q.A.	
		THREE PLACE DECIMAL ±	COMMENTS:	
		INTERPRET GEOMETRIC TOLERANCING PER:		
		MATERIAL		
NEXT ASSY	USED ON	FINISH		
APPLICATION		DO NOT SCALE DRAWING		

3 1/2" ALUMINUM TUBE

TITLE:
 BEL26"-6-PST-SHK-125W-TBK-CFA-40K-TP3

SIZE	DWG. NO.	REV
A		
SCALE: 1:4	WEIGHT:	SHEET 13 OF 15

