

#PA BC "	D5FHBI A 69F	89G7 F-DHC B	E HM 7 I H
%	B@!%\$!+\$K !+!@)!&: M* 7 M@B 89F	*"5@ A -B I A '7 M@B 89F	%
&	B@!%\$!+\$K !+!@)!&: MFC I B 8 '5 B 7 < C F 'D@5H9	5@ A -B I A '\$)' '\$\$' 'D@5H9	%
'	B@!%\$!+\$K !+!@)!&: M5B 7 < C F 'H 6	5@ A -B I A '\$)' '\$\$' 'D@5H9	(
(B@!%\$!+\$K !+!@)!&: MHC DFC I B 8 '5 7 7 9BH	5@ A -B I A '\$%' '\$\$' 'D@5H9	&
)	B@!%\$!+\$K !+!@)!&: MGDI B 'H 6 9 7 5 D 'H C D	GDI B '5@ A -B I A '\$\$, '\$'	(
*	B@!%\$!+\$K !+!@)!&: MGDI B 'H C D '7 5 D	GDI B '5@ A -B I A '\$\$, '\$'	%
+	B@!%\$!+\$K !+!@)!&: MGDI B '7 M@B 89F': #HF 'H C D	GDI B '5@ A -B I A '\$\$, '\$'	%
,	B@!%\$!+\$K !+!@)!&: MGDI B '7 M@B 89F': #HF	GDI B '5@ A -B I A '\$\$, '\$'	%
-	B@!%\$!+\$K !+!@)!&: MGDI B 'H 6 9 7 5 D '6 C 'H C A	GDI B '5@ A -B I A '\$\$, '\$'	(
%\$	B@!%\$!+\$K !+!@)!&: M8F # 9F '6F 5 7 ? 9H	5@ A -B I A '\$\$*')"	%
%%	B@!%\$!+\$K !+!@)!&: MFC I B 8 '6 5 F	%#&"5@ A -B I A 'FC I B 8 '6 5 F	(
%&	B@!%\$!+\$K !+!@)!&: M7 5 GH 6 F 5 7 ? 9H	GHC 7 ? 7 5 GH D 5 FH	%
%	B@!%\$!+\$K !+!@)!&: M: @GG @BG	GHC 7 ? : @GG @BG	%

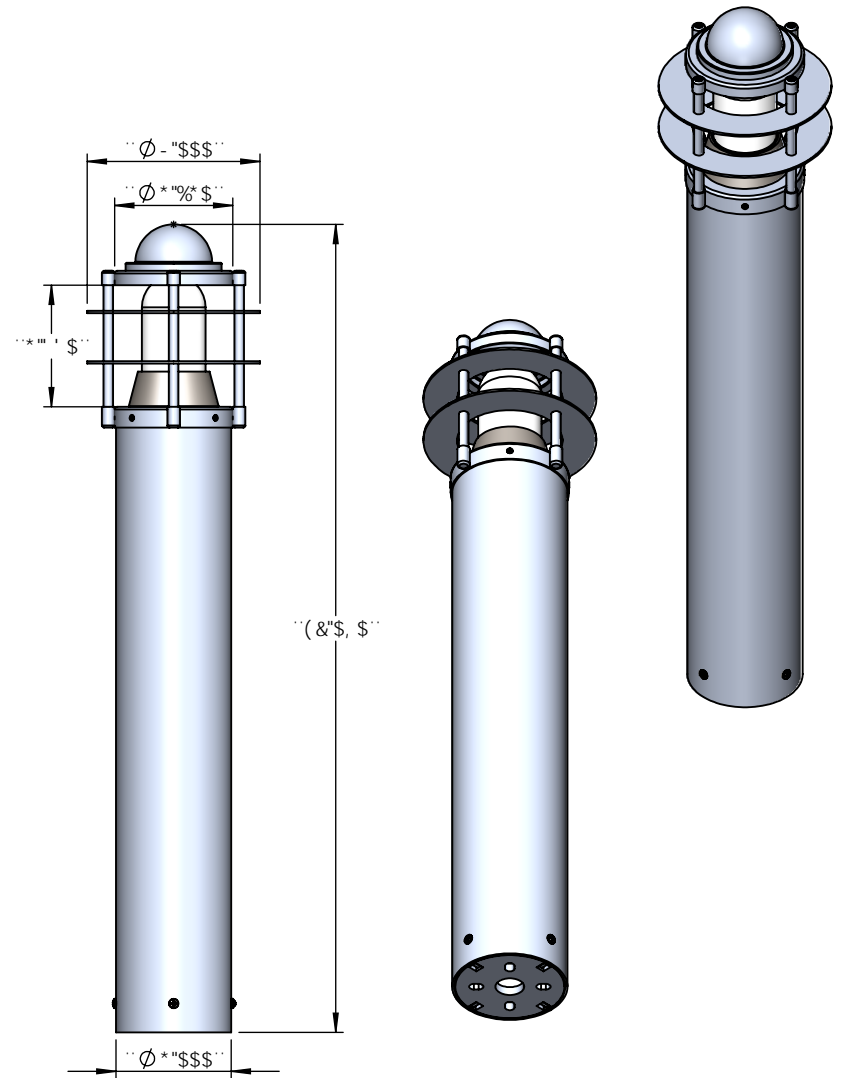
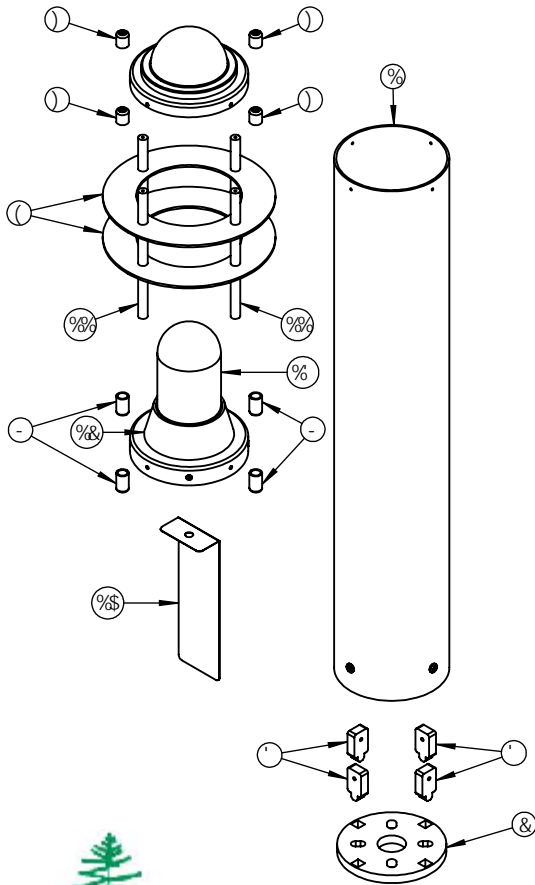

I B @GG C H: 9FK @9 GD97 ÷ 98.	B5A 9	85H9	
8-A 9BG@BG5F9-B 'B7 < 9G HC @F 5B 7 9G : F57 HC B 5 @± "\$\$' 5B: I @F: A 57 < ± "\$%'' 69B 8 ± HK C D@5 7 9 8 97 A 5 @'' ± H:F99D@5 7 9 8 97 A 5 @ ± "\$\$%	8F5K B		H#@.
	7 < 97 ? 98		
	9B: 5DDF"		B@!%\$!+\$K !+!@)!&: M
	A: : 5DDF"		
	E "5"		
BHFDF 9H: 9C A 9F 7 HC @F 5B 7 B: D9F. A 5HF 5@	7 C A A 9BHG		G#9 8K ; "'BC"
			5 H7 ? 9H&' &) +
: B @<			F9J
8C B@HG7 5 @9 8F5K B:			G7 5 @. % % \$ K 9 ÷ < H'
			G < 99H % C : ' % %

)

(

&

%

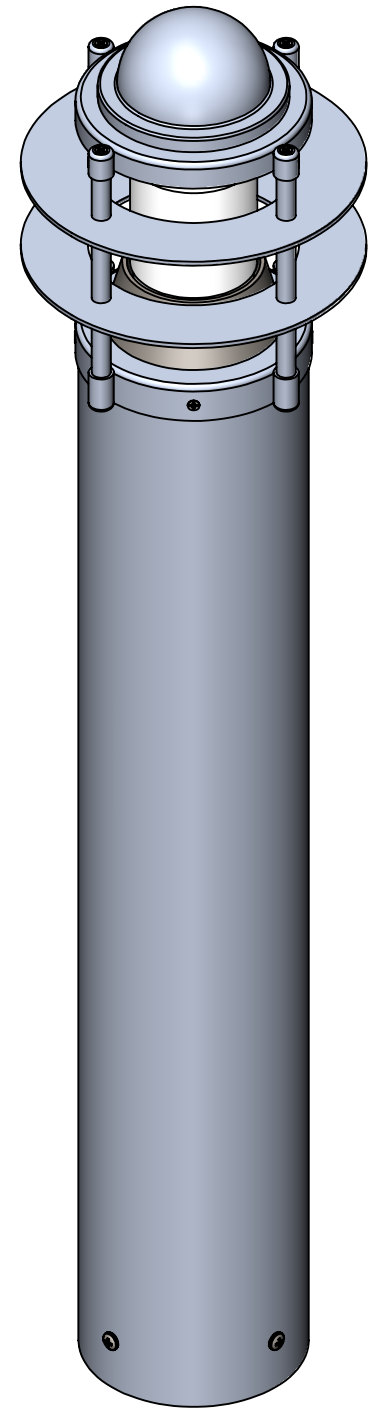
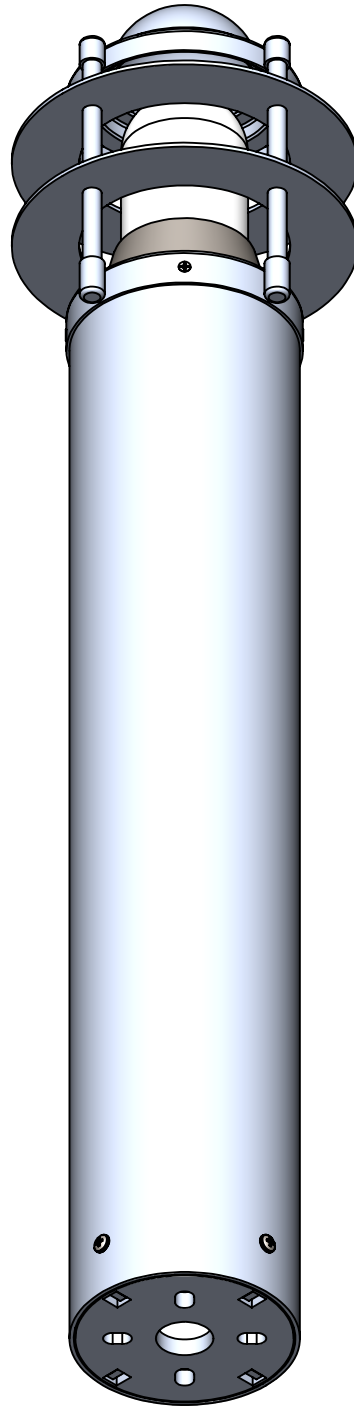
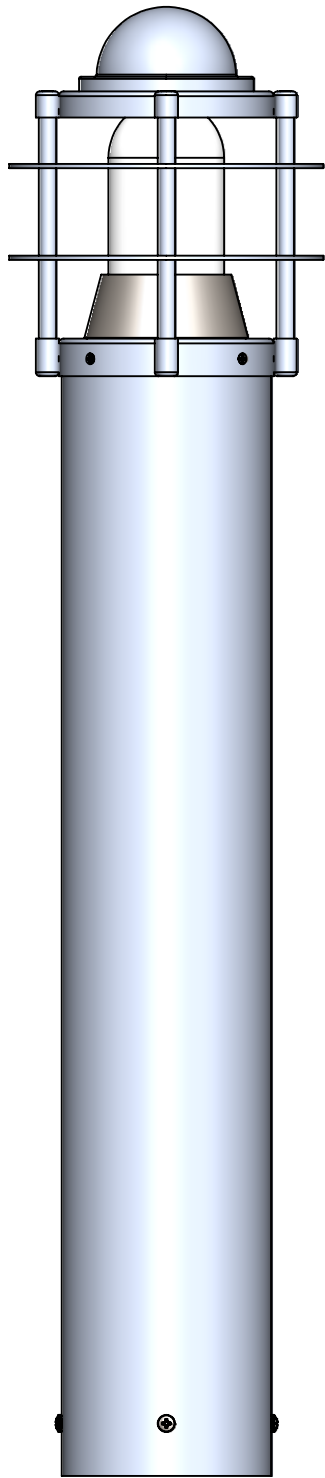

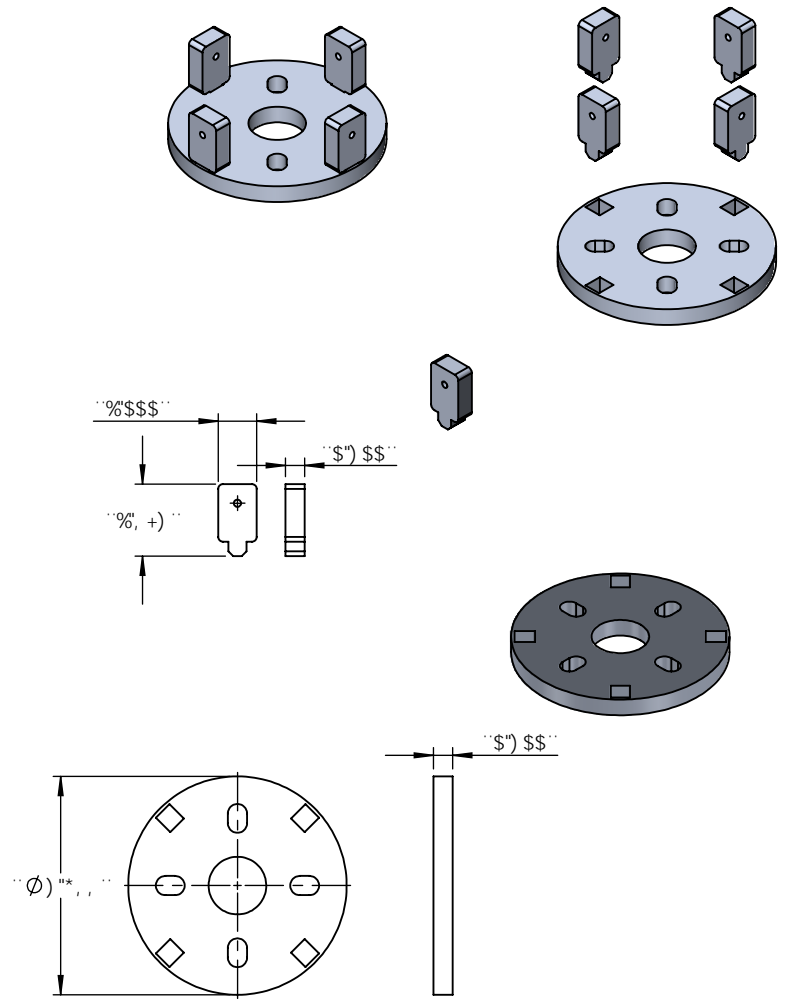
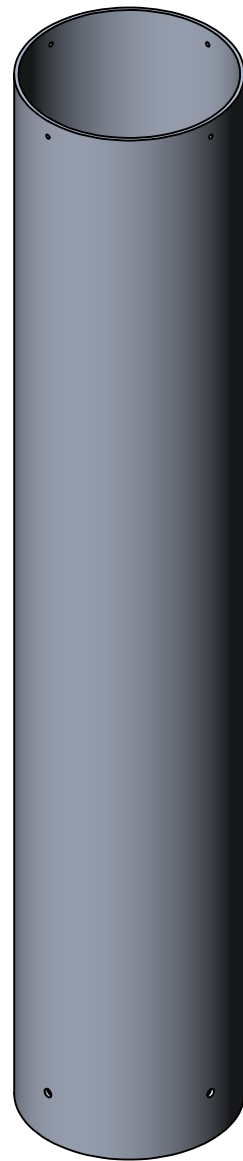
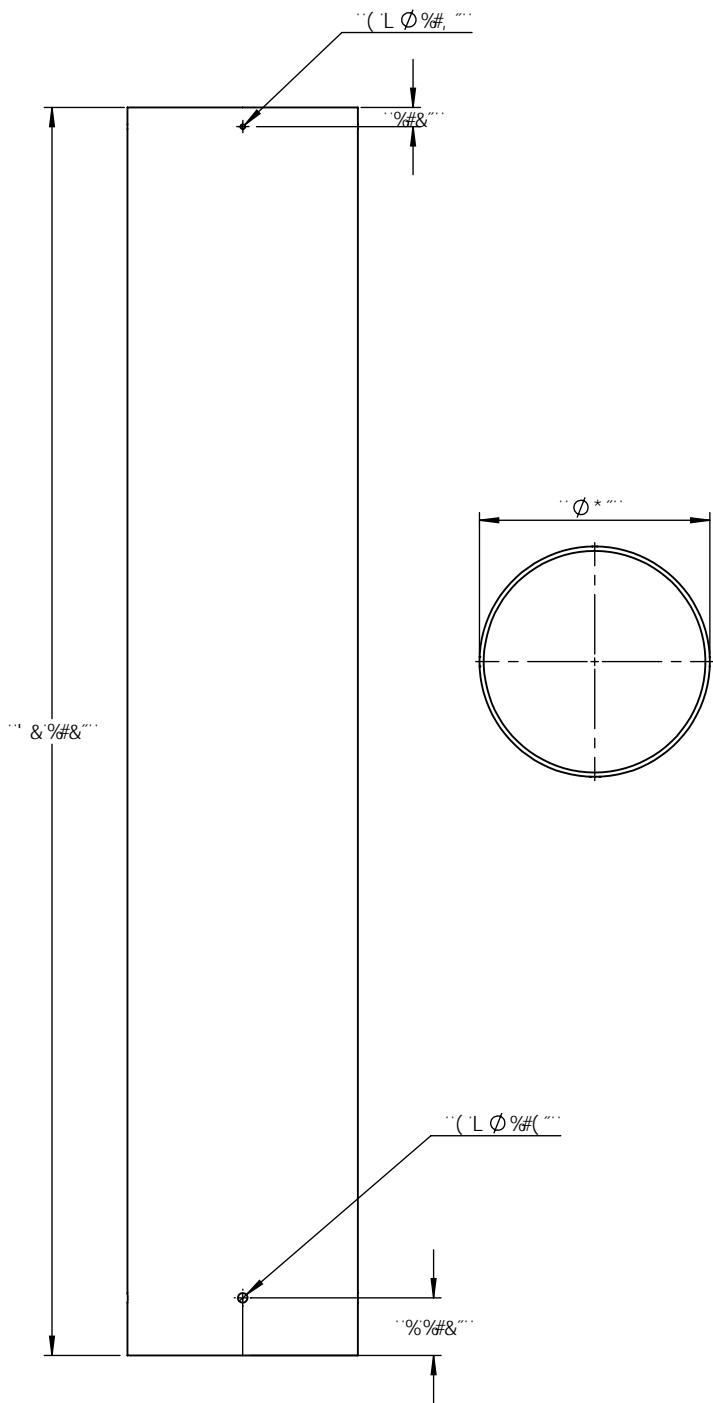

BH9DF9H; 9CA 9FF 7
HC @F 5B7 B; D9F.
A 5H9F 5@
: B G<
8C BCHG75 @98F5K B;

	B5A 9	85H9	* "5@ A B I A 7 M @ B 8 9 F
8F5K B			H# @.
7 < 97 ? 98			B @ ! % \$! + \$ K ! + ! @) ! & ! ; M
9B; 5DDF"			
A :: 5DDF"			
E "5"			
7 C A A 9BHG			
			G# 9 8 K ; "BC "
			F9J
			G7 5 @. %) K 9 > < H ' G < 99 H ' C : % %

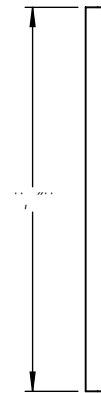
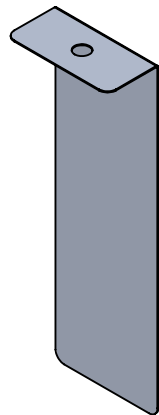
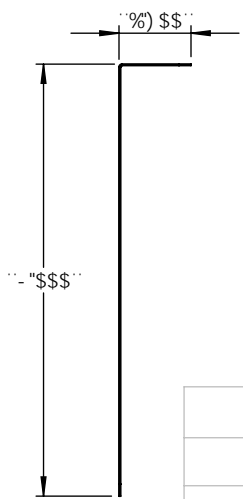
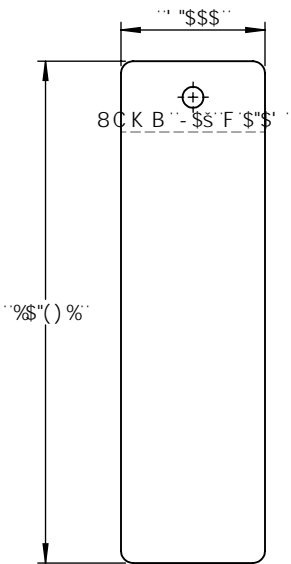
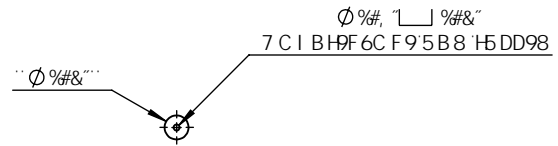
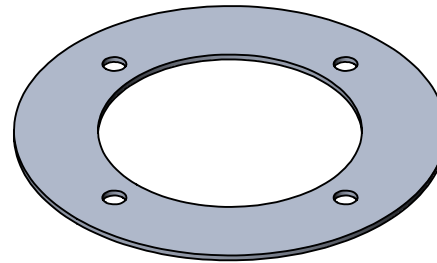
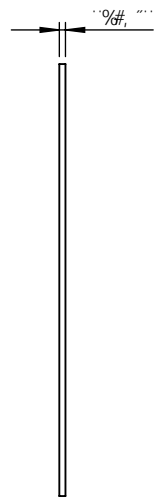
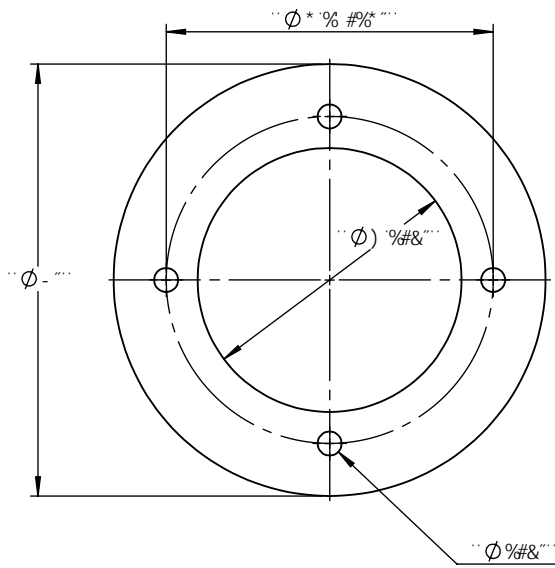

DFC DF 5 FM 5 B 8 7 C B : 8 9 B H 5 @
 H: 9 B: C F A 5 H C B 7 C B H 5 B 9 8 B H: 6
 8 F 5 K B: 6 H: 9 G C @ D F C D 9 F H M C:
 O B G 9 F H 7 C A D 5 B M B 5 A 9 < 9 F 9 2 " 5 B M
 F 9 D F C 8 1 7 H C B B D 5 F H C F 5 G 5 K < C @
 K H: C 1 H H: 9 K F H 9 B D 9 F A 6 G C B C:
 O B G 9 F H 7 C A D 5 B M B 5 A 9 < 9 F 9 2 G
 D F C < 6 H 9 8 "

		I B @ G G C H: 9 F K 6 9 G D 9 7 ÷ 9 8.		B 5 A 9	8 5 H 9	5 @ A B I A '\$"%&)" "D @ 5 H 9
		8 A 9 B G C B G 5 F 9 B B 7 < 9 G H C @ F 5 B 7 9 G : F 5 7 H C B 5 @ ± 5 B: I @ 5 F: A 5 7 < ± 6 9 B 8 ± H K C D @ 5 7 9 8 9 7 A 5 @ ± ± H: F 9 9 D @ 5 7 9 8 9 7 A 5 @ ±	8 F 5 K B			H # @.
		B H F D F 9 H: 9 C A 9 F 7 H C @ F 5 B 7 B: D 9 F.	7 < 9 7 ? 9 8			B @ ! % \$! + \$ K ! + ! @) ! & ! ; M
		A 5 H F 5 @	9 B: 5 D D F "			
			A: : 5 D D F "			
			E " 5 "			
			7 C A A 9 B H G			
B 9 L H 5 G G M	I G 9 8 C B	: B 6 <				G A 9 8 K ; " " B C " F 9 J
5 D D @ 7 5 H C B	8 C B C H G 7 5 @ 8 F 5 K B:					G 7 5 @ . % (K 9 ÷ < H ' G < 9 9 H (' C : ' % %

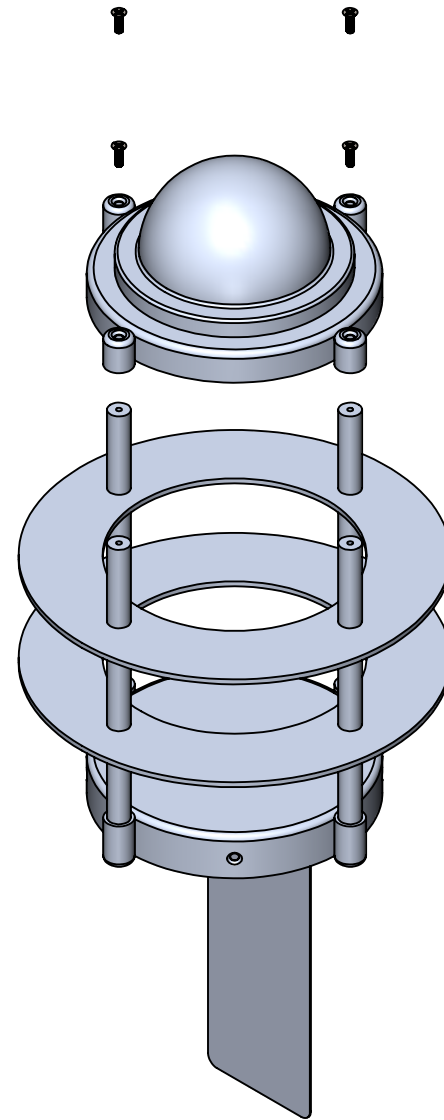
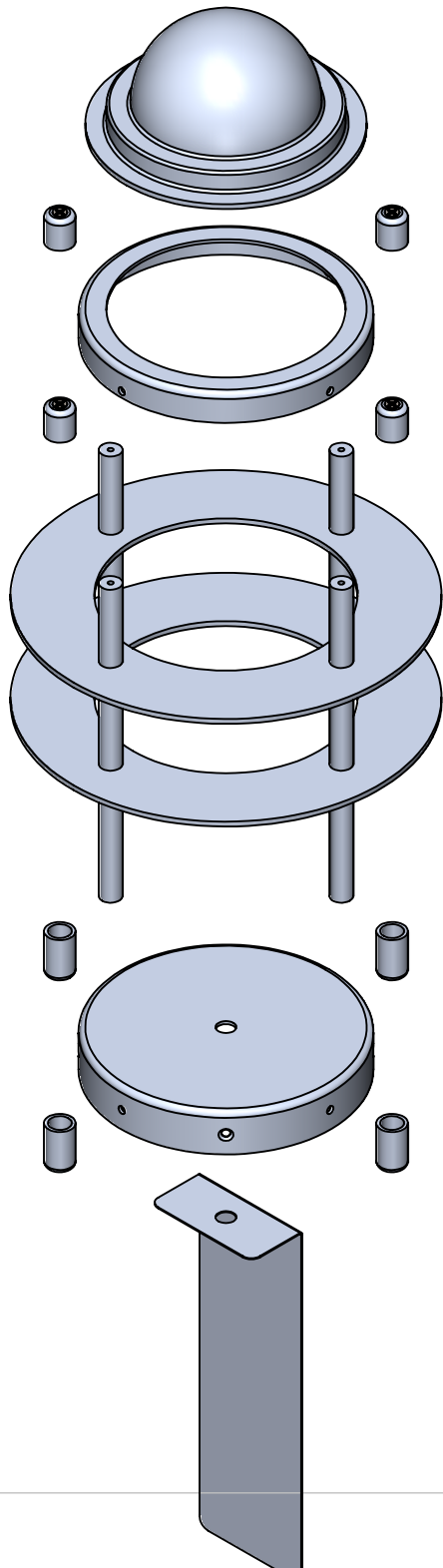

5@K 9@98 BHC CB9D-97 9

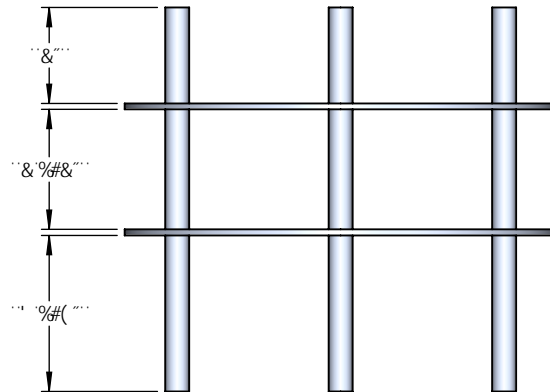
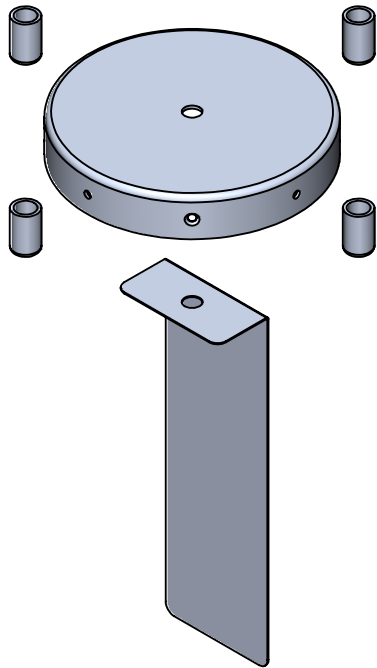
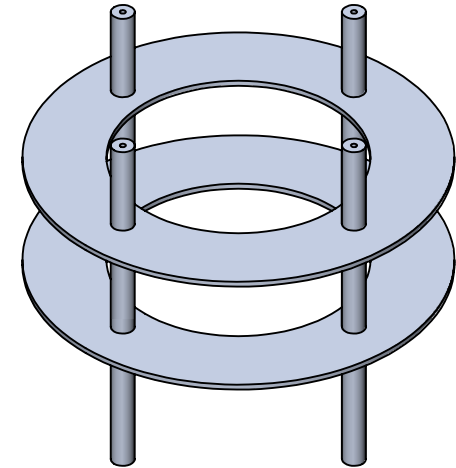
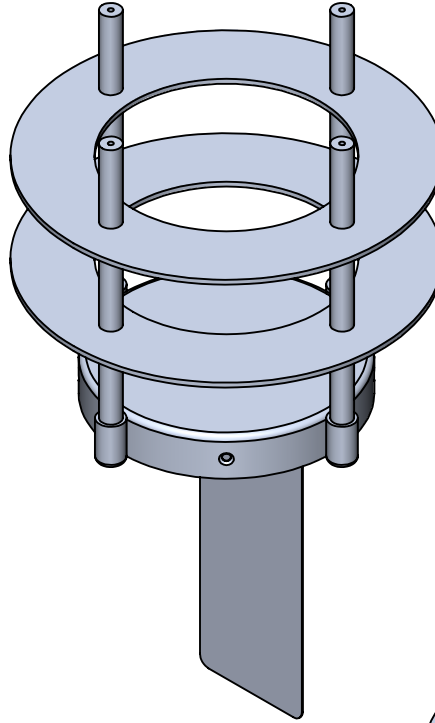
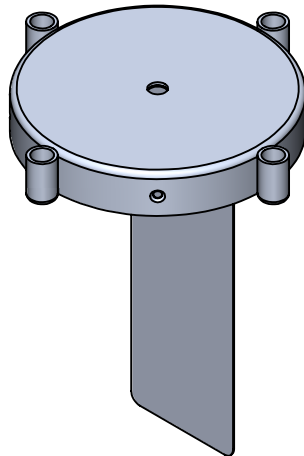
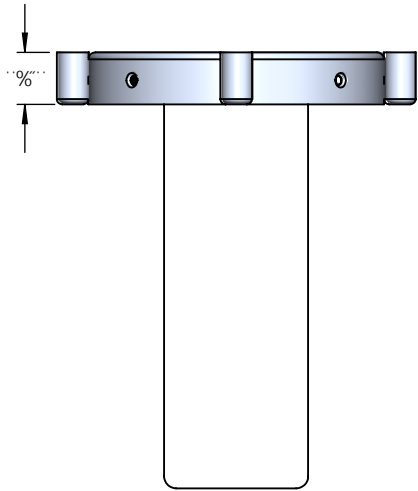

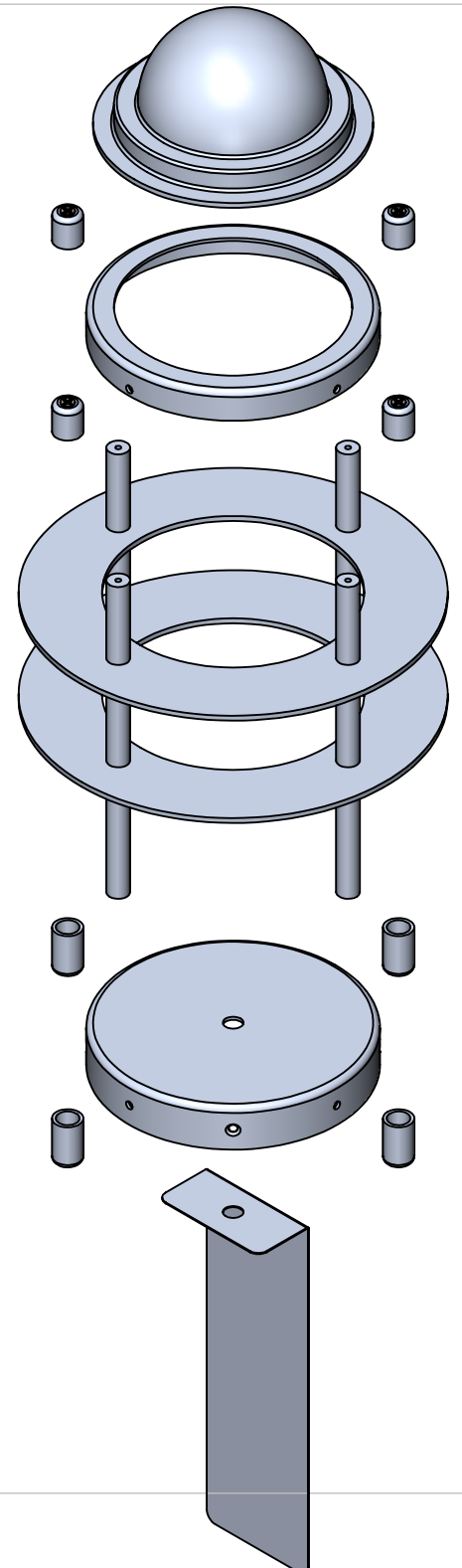
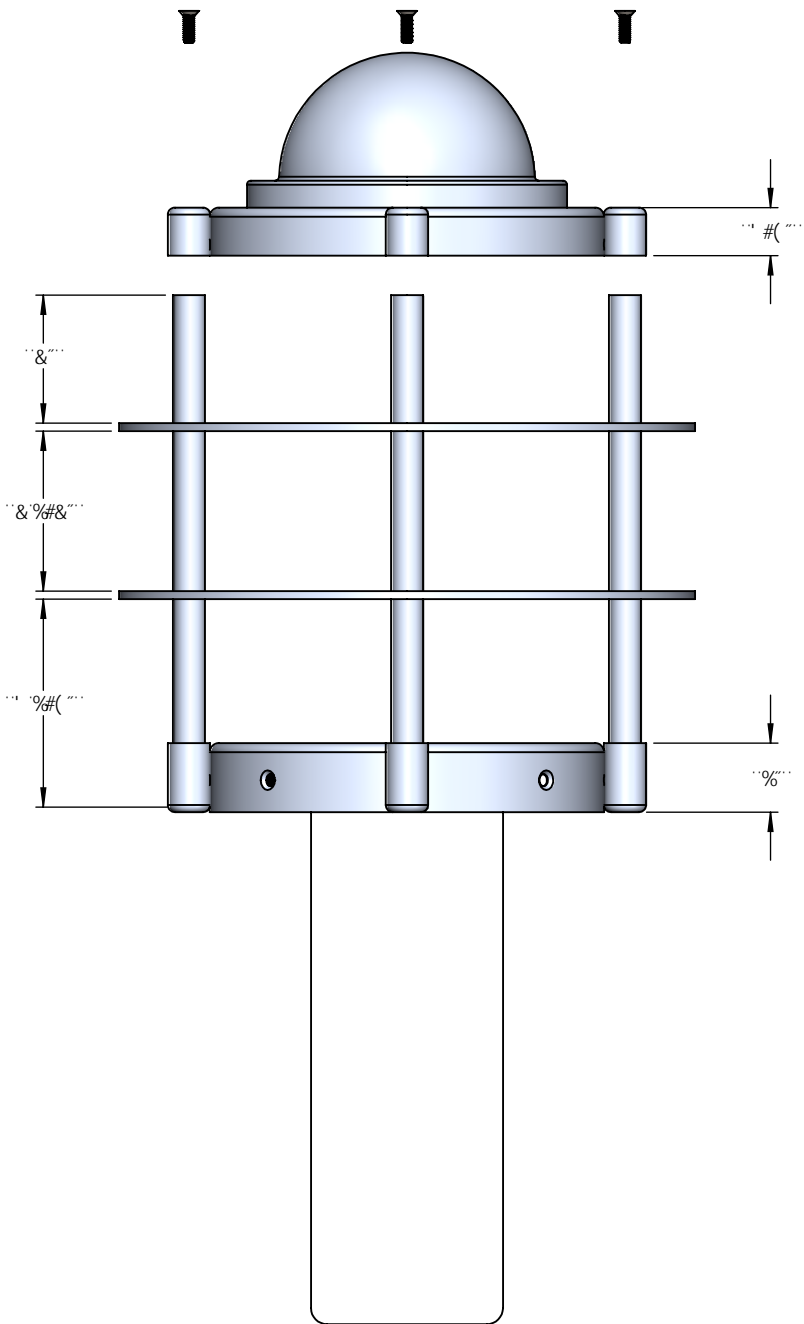

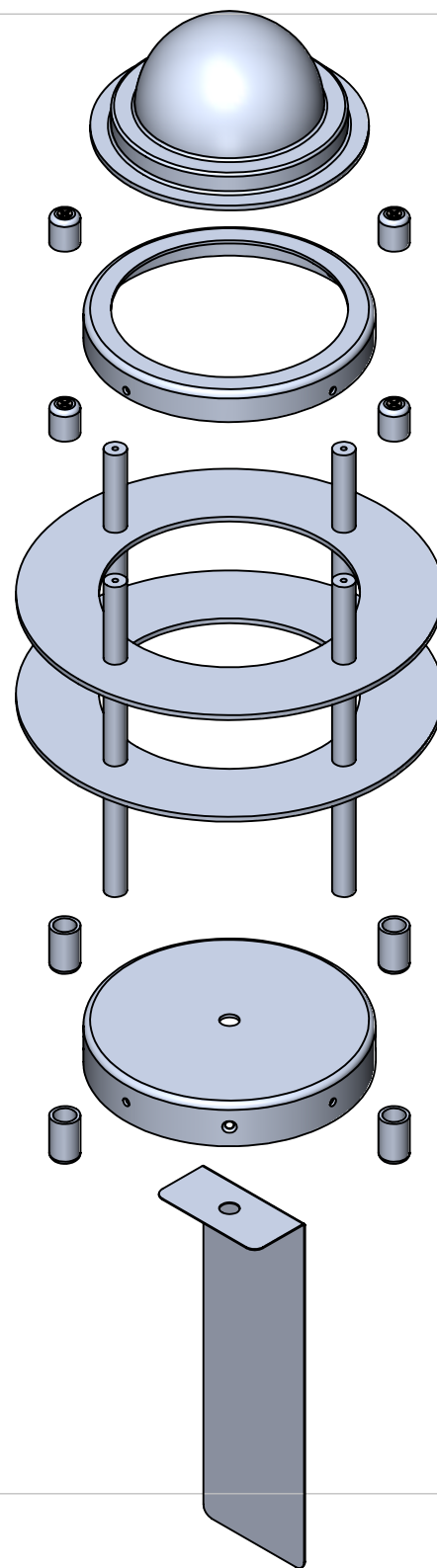
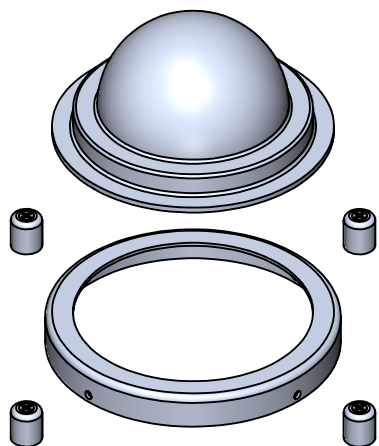
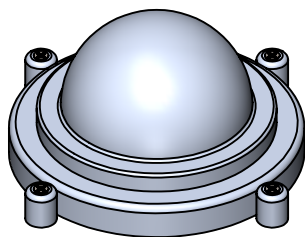

#PA BC "	D5FHBI A 69F	8 9G7 F-DHC B	E HM
%	B @ ! % \$! + \$ K ! + ! @) ! & ; M GDI B HC D 7 5 D	GDI B ' 5 @ A B I A '\$ \$, \$ '	%

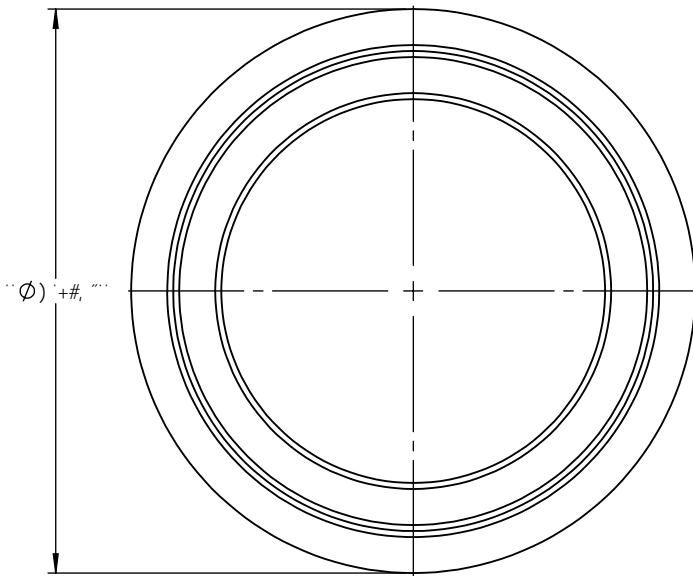
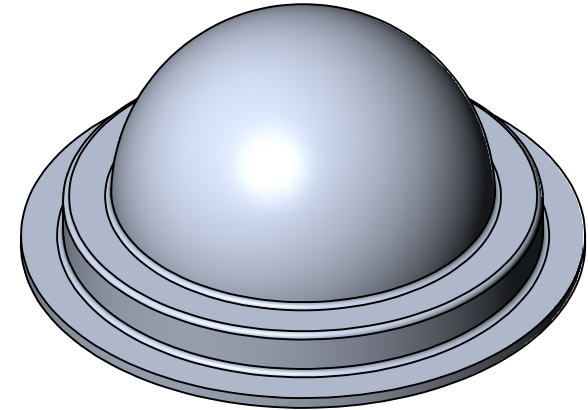
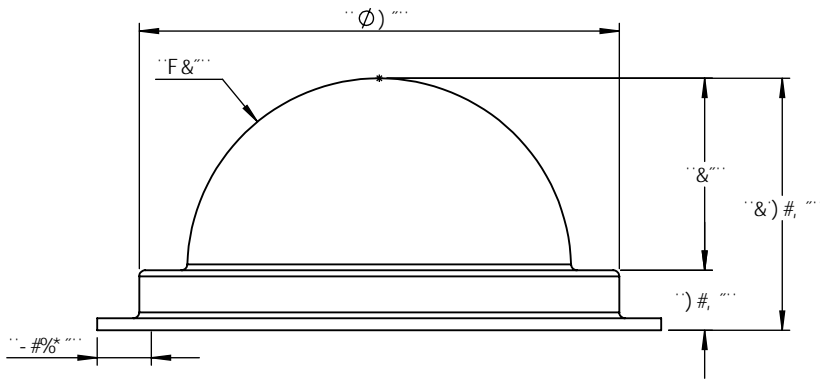

DFC DF 5 FM 5 B 8 7 C B : 8 9 B H 5 @
 H: 9 B: CFA 5HC B 7 C B H 5 B 9 B B H: 6
 8 F 5 K B: 6 H: 9 G C @ DFC D 9 F H M C:
 O B G 9 F H 7 C A D 5 B M B 5 A 9 < 9 F 9 2 " 5 B M
 F 9 D F C 8 1 7 H C B B D 5 F H C F 5 G 5 K < C @
 K H: C 1 H H: 9 K F H 9 B D 9 F A 6 G C B C:
 O B G 9 F H 7 C A D 5 B M B 5 A 9 < 9 F 9 2 G
 D F C < 6 H 9 8 "

		I B @ G G C H: 9 F K 6 9 G D 9 7 ÷ 9 8.		B 5 A 9	8 5 H 9	GDI B ' 5 @ A B I A '\$ \$, \$ '
		8 A 9 B G C B G 5 F 9 B B 7 < 9 G H C @ F 5 B 7 9 G : F 5 7 H C B 5 @ ± 5 B: I @ 5 F: A 5 7 < ± " 6 9 B 8 ± H K C D @ 5 7 9 8 9 7 A 5 @ ± ± H: F 9 9 D @ 5 7 9 8 9 7 A 5 @ ±	8 F 5 K B 7 < 9 7 ? 9 8 9 B: 5 D D F " A: : 5 D D F "			
		B H 9 F D F 9 H: 9 C A 9 F 7 H C @ F 5 B 7 B: D 9 F. A 5 H 9 F 5 @	E " 5 " 7 C A A 9 B H G			G A 9 8 K ; " " B C " F 9 J
B 9 L H 5 G G M	I G 9 8 C B	: B @ <				G 7 5 @ . % & K 9 ÷ < H ' G < 9 9 H - ' C : ' % %
	5 D D @ 7 5 H C B	8 C B C H G 7 5 @ 9 8 F 5 K B:				

)

(

&

%

±9A 'BC "	D5FHBI A 69F	8 9G7 F-DHC B	E HM
%	B @!%\$!+\$K !+!@)!&!; MGDI B '7 M@B89F : ±H9F	GDI B '5 @ A -BI A '\$"\$, \$"	%

±9A 'BC "	D5FHBI A 69F	8 9G7 F-DHC B	E HM
%	B @!%\$!+\$K !+!@)!&!; MGDI B '7 M@B89F : ±H9F 'HC D	GDI B '5 @ A -BI A '\$"\$, \$"	%

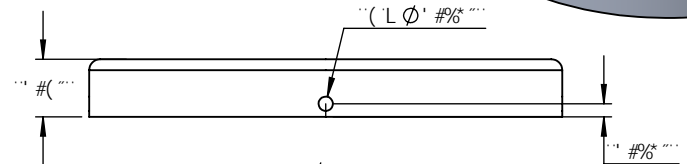
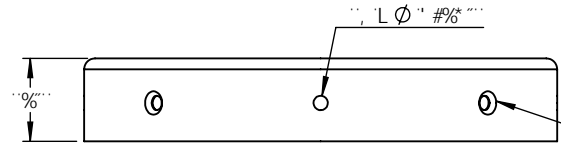
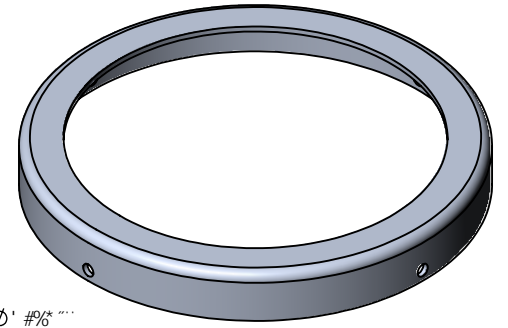
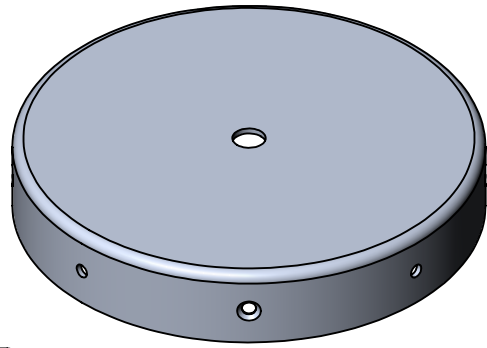

('7 <5A : 9F98 : C F'
: @H<958 G7 F9K

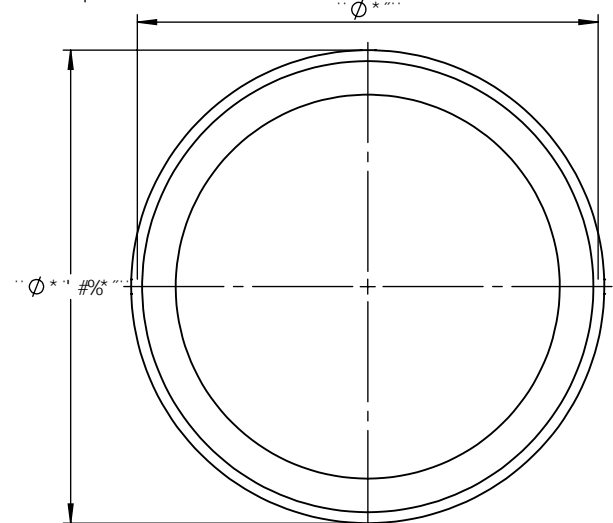
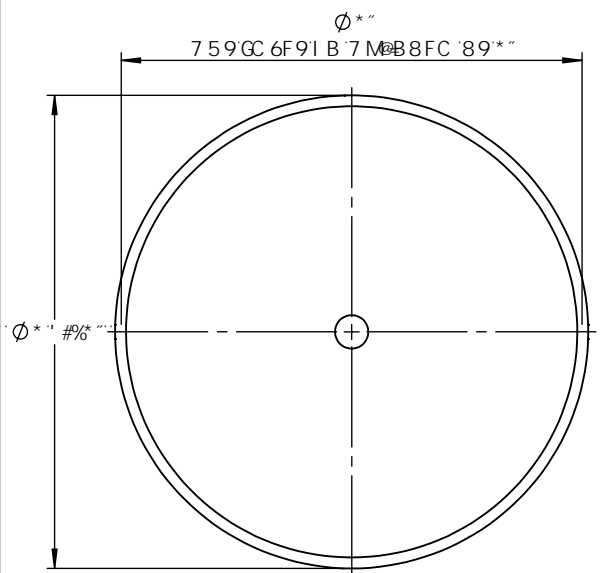

DFC DF-915FM5B87CB: @9BH5@
 H:9 B: CFA 5HC B 7 C B15-B98 -B H:6
 8F5K -B: @GH:9GC @DFC D9FHMC:
 OBG9FH7 CA D5BMB5A 9<9F92'' 5BM
 F9DFC 81 7 HC B -B D5FHCF 5G5'K <C @
 K H:C1 H:9K F H@B D9FA @GC B C:
 OBG9FH7 CA D5BMB5A 9<9F92 -G
 DFC <6#98*

		I B @GGC H:9FK @9GD97 @98.		B5A 9	85H9
		8-A 9BG@BG5F9-B -B7<9G HC @F5B7 9G :F57 HC B5@± 5B: I @5F: A 57 <±''''69B8 ± HK C D@57 9897 -A 5@''± H:F99D@57 9897 -A 5@±	8F5K B 7<97?98 9B: 5DDF" A: : 5DDF"		
		-BH9FDF9H: 9CA 9FF 7 HC @F5B7 B: D9F. A 5H9F 5@	E "5" 7 C A A 9BHG		
B9LH5GGM	I G98 C B	:B @<			
5DD@7 5HC B		8C B CHG7 5 @98F5K B:			

GDI B '5 @ A -BI A '\$"\$, \$"	
H#@.	
B @!%\$!+\$K !+!@)!&!; M	
G#9 5	8K ; "'BC" F9J
G7 5 @. %&)"K 9≠ <H'	G<99H%\$'C : '%%

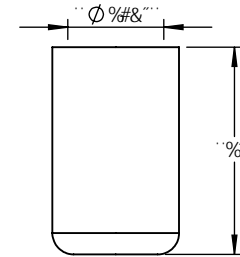
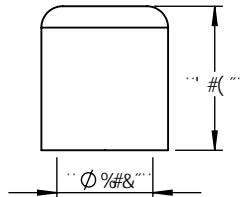
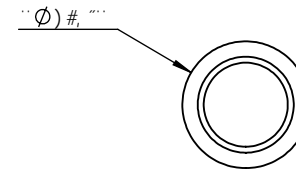
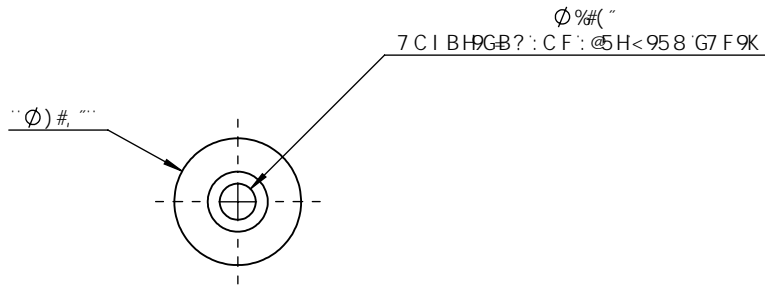
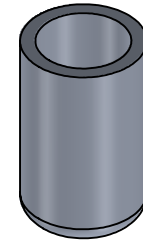

DFC DF 9 5 FM 5 B 8 7 C B : 8 9 B H 5 @
 H 9 B : C F A 5 H C B 7 C B H 5 B 9 8 B H 6
 8 F 5 K B : 6 H 9 G C @ D F C D 9 F H M C :
 O B G 9 F H 7 C A D 5 B M B 5 A 9 < 9 F 9 2 " 5 B M
 F 9 D F C 8 1 7 H C B B D 5 F H C F 5 G 5 K < C @
 K 4 C 1 H H 9 K F H 9 B D 9 F A 6 G C B C :
 O B G 9 F H 7 C A D 5 B M B 5 A 9 < 9 F 9 2 6
 D F C < 6 H 9 8 "

		I B @ G G C H : 9 F K @ 9 G D 9 7 ÷ 9 8 .	B 5 A 9	8 5 H 9	G D I B ' 5 @ A B I A '\$ \$, \$ "		
		8 A 9 B G C B G 5 F 9 B B 7 < 9 G H C @ F 5 B 7 9 G : F 5 7 H C B 5 @ ± 5 B : I @ 5 F : A 5 7 < ± 6 9 B 8 ± H K C D @ 5 7 9 8 9 7 A 5 @ ± ± H K F 9 9 D @ 5 7 9 8 9 7 A 5 @ ±	8 F 5 K B			H # @ .	
		B H 9 F D F 9 H : 9 C A 9 F 7 H C @ F 5 B 7 B : D 9 F .	7 < 9 7 ? 9 8		B @ ! % \$! + \$ K ! + ! @) ! & ; M		
		A 5 H 9 F 5 @	9 B : 5 D D F "				
	B 9 L H 5 G G M	I G 9 8 C B	A : : 5 D D F "		G A 9	8 K ; " " B C "	F 9 J
	5 D D @ 7 5 H C B	8 C B C H G 7 5 @ 9 8 F 5 K B :	E " 5 "		5		
			7 C A A 9 B H G			G 7 5 @ . % %	K 9 ÷ < H '