

#PA BC "	D5FHBI A 69F	89G7 F-DHC B	E HM	7 I H
%	5FIK !&(!, K !A K !K 5!')?!: F5A 9	&&; 5I ; 9	%	
&	5FIK !&(!, K !A K !K 5!')?!657?D@5H9	&&; 5I ; 9	%	
'	5FIK !&(!, K !A K !K 5!')?!657?D@5H9GF-D7CJ 9F	&&; 5I ; 9	%	
(5FIK !&(!, K !A K !K 5!')?!657?D@5H9H56	&&; 5I ; 9	&	
)	5FIK !&(!, K !A K !K 5!')?!57FM@7	57FM@7	%	
*	9gdYbH97 <S%&\$&+J SG?I , \$, \$+*	8FJ 9F	%	
+	5`HJ`@98`DB`%)6!%@4GG	@98	&	

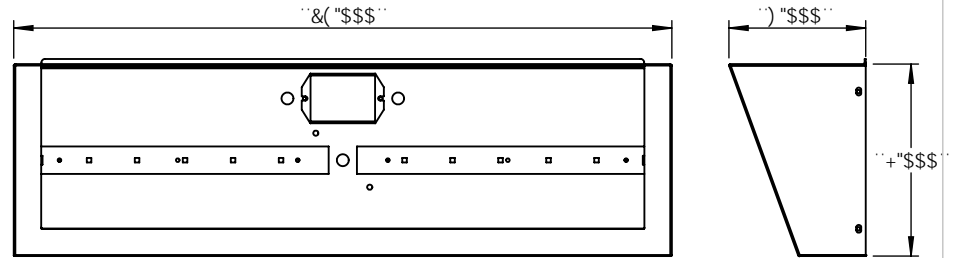

I B @GGC H: 9FK 69 GD97 ÷ 98.	B5A 9	85H9	5FIK !&(!, K !A K !K 5!') ?
8A 9BGC BG5F9 B`B7 <9G HC @F5B7 9G : F57 HC B5 @± "\$\$" 5B; I @F: A 57 < ± "\$\$""69B8 ± HK C D@57 9897 A 5@ ± "\$\$" H: F99D@57 9897 A 5@ ± "\$\$"	8F5K B		
BH@DF9H: 9CA 9F7 HC @F5B7 B: D9F. A 5H@F 5@	7 <97 ?98	9B: 5DDF"	
: B @<	A: : 5DDF"	E "5"	
5 @69B8`F58+ G"\$`\$`"	7 C A A 9BHG		G@9 8K ; ""BC "
5DD@7 5HC B	8C B CHG7 5 @98F5K B:		5 H7 ?9H&' &, +
			G7 5 @. % + K 9 ÷ <H'
			G <99H%C :)

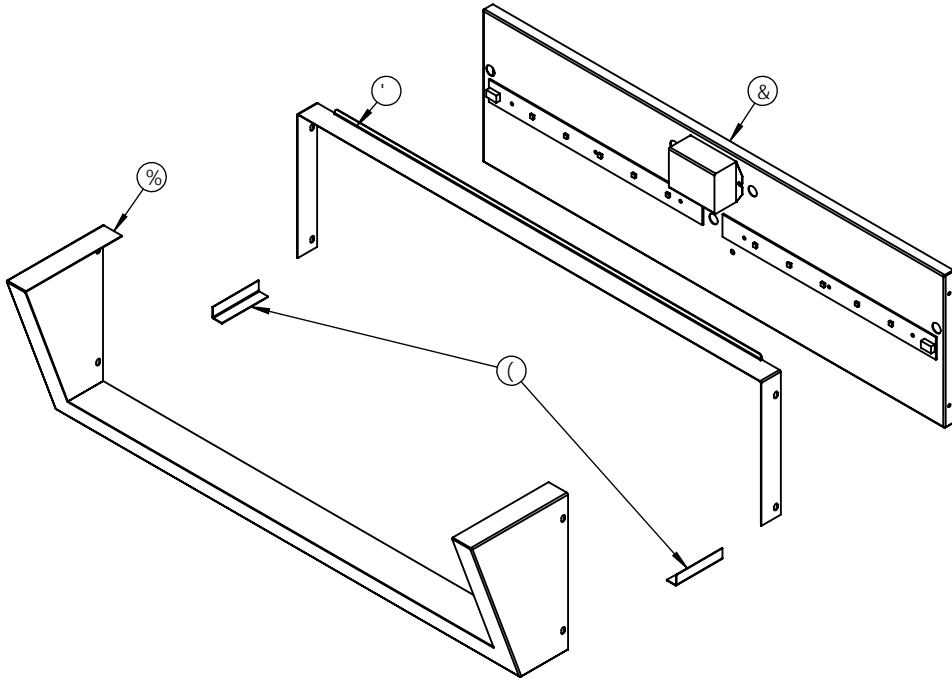
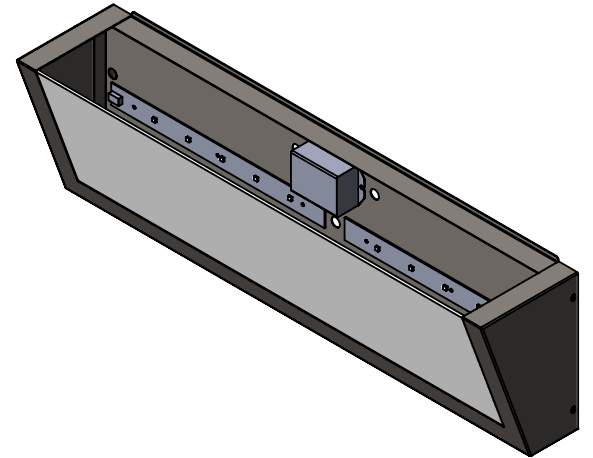

EVERGREEN LIGHTING

) ↑ (' & %

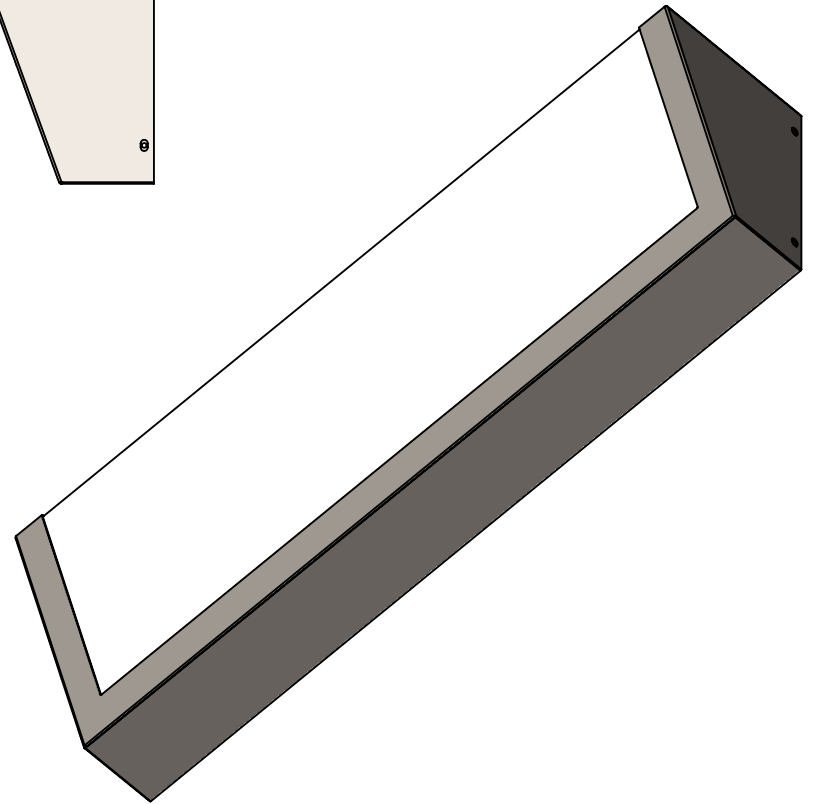
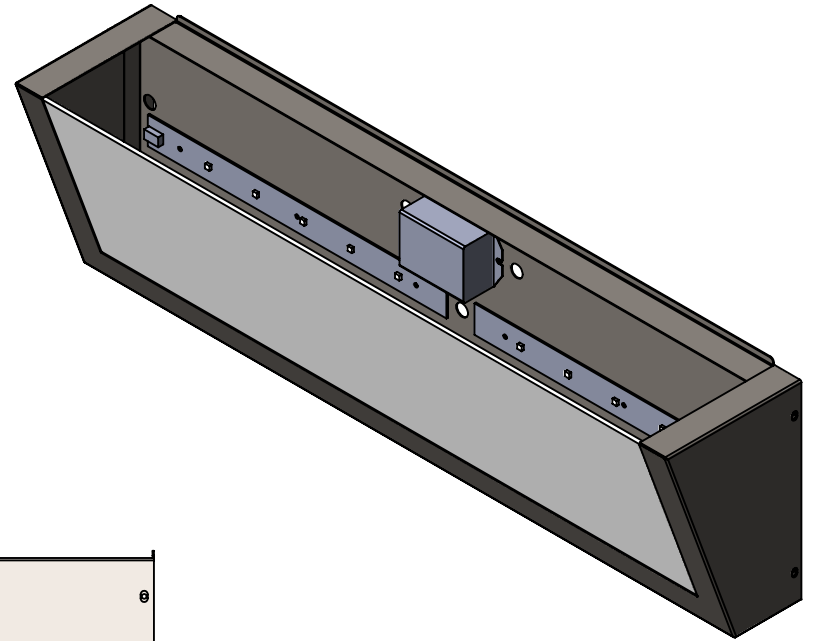
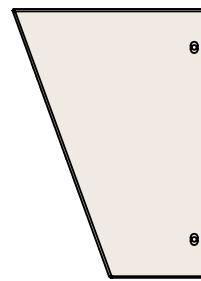

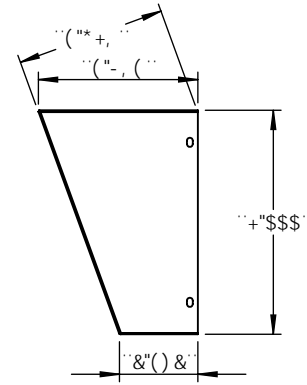
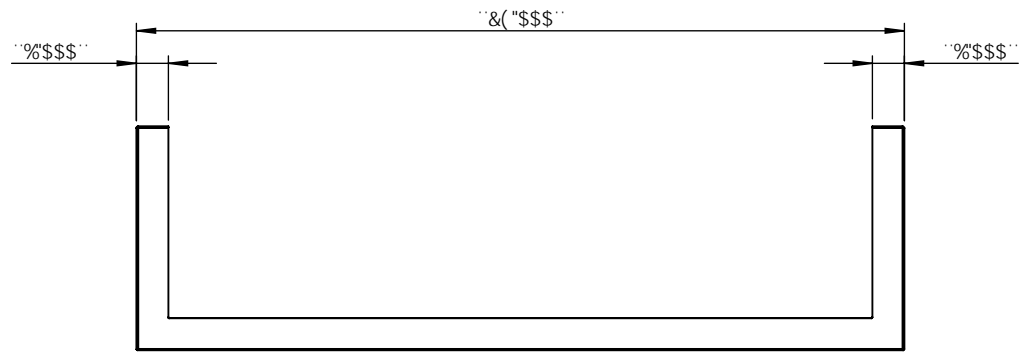
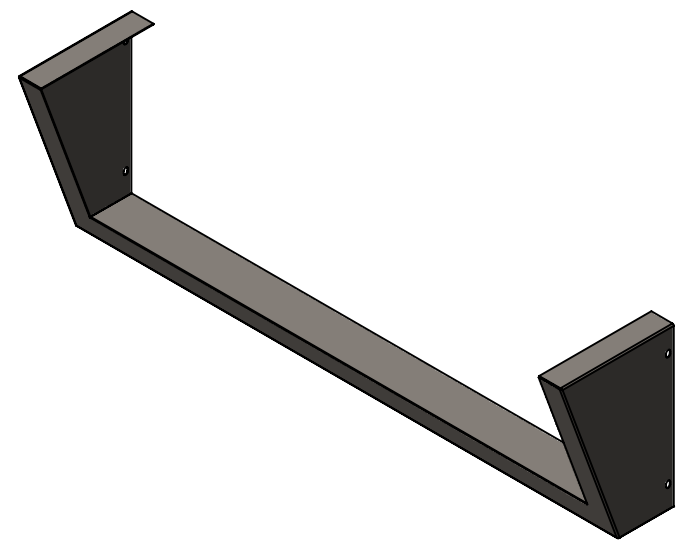
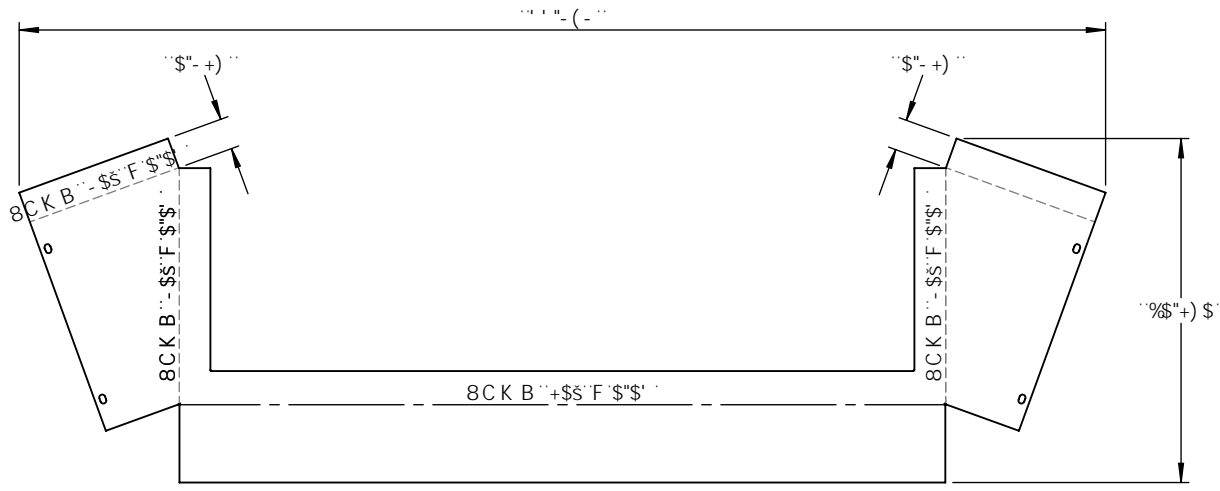

<p>DFC DF 5FM5B87CB: 89B H5@</p> <p>H:9 B: CFA 5HC B 7 C B H5 B 98 B H:6</p> <p>8F5K B: 6H:9 GC @DFC D9FHVC:</p> <p>OBG9FH7 CA D5BMB5A 9<9F92" 5BM</p> <p>F9DFC 81 7 HC B B D5FHCF 5G5 K <C @</p> <p>K H:C I H:9 K F H9B D9FA 6GC B C:</p> <p>OBG9FH7 CA D5BMB5A 9<9F92" 6</p> <p>DFC <6H98*</p>	<p>B9LH5GGM</p> <p>I G98 C B</p>	<p>I B @GGC H:9FK 69 GD97 ÷ 98.</p> <p>8 A 9BG C BG5F9 B B7 <9G</p> <p>HC @F 5B7 9G</p> <p>: F57 HC B5 @±</p> <p>5B: I @F: A 57 <±69B 8 ±</p> <p>HC C D @5 7 9 8 97 A 5 @ ±</p> <p>H: F99 D @5 7 9 8 97 A 5 @ ±</p>	<p>8F5K B</p> <p>7 <97 ?98</p> <p>9B: 5DDF"</p> <p>A: : 5DDF"</p> <p>E "5"</p> <p>7 C A A 9BHG</p>	<p>B5A 9</p> <p>85H9</p>	<p>&&; 5I; 9</p> <p>H#@.</p> <p>5FIK !&(!, K !A K !K 5!') ?</p>
<p>5DD@7 5HC B</p>	<p>8C B CHG7 5 @ 8F5K B:</p>				<p>G7 5 @. %* K 9 ÷ <H'</p> <p>G<99H' 'C:)</p>

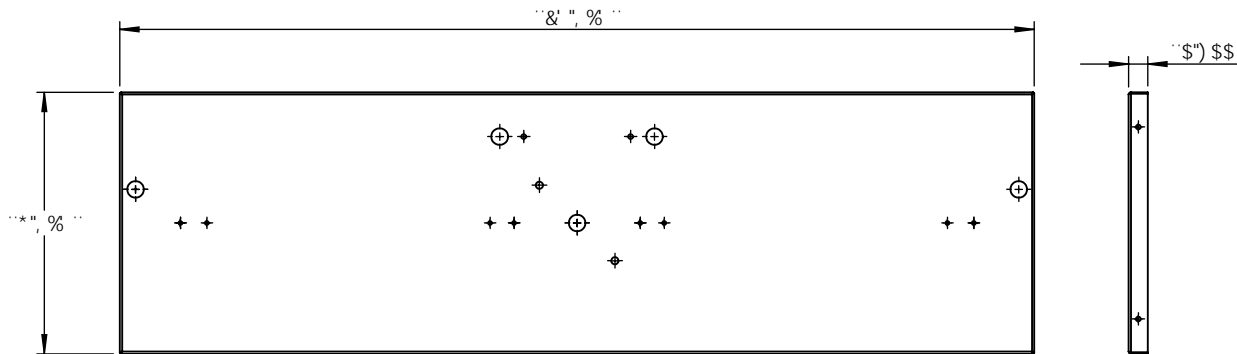
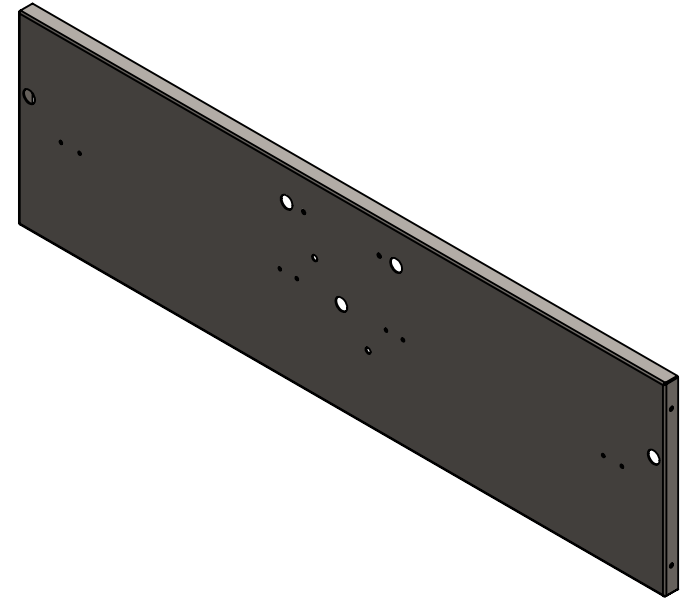
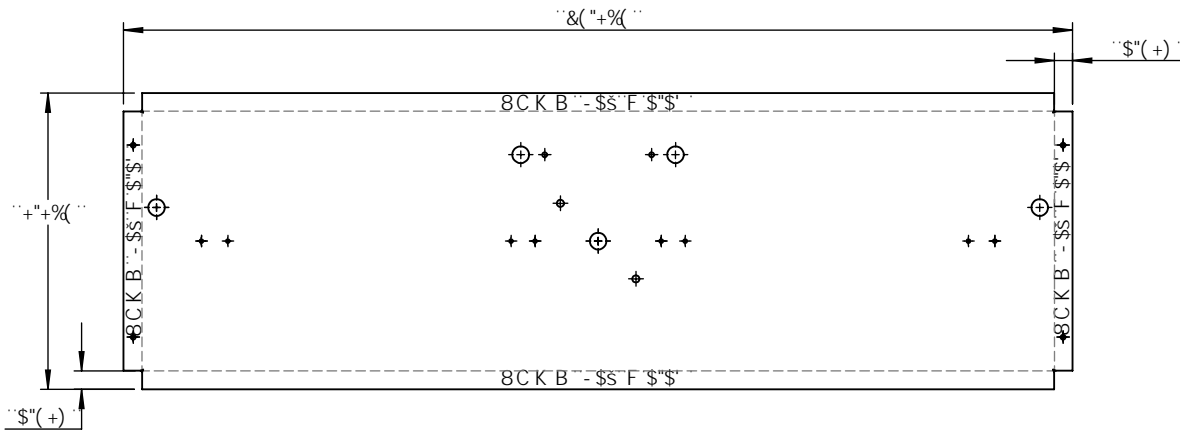

DFC DF 5FM5B87CB: 89BH5@
 H:9 B: CFA 5HC B 7 C B H5 B 98 B H:6
 8F5K B: 6H:9 GC @DFC D9F HVC:
 OBG9FH7 CA D5BMB5A 9<9F92" 5BM
 F9DFC 81 7 HC B B D5FHCF 5G5 K <C @
 K H:C I H:9K F H9B D9FA 6GC B C:
 OBG9FH7 CA D5BMB5A 9<9F92 6
 DFC <6#98"

		I B @GGCH:9FK 69 GD97 ÷ 98.		B5A 9	85H9	&&; 5I; 9	
		8 A 9BG@BG5F9 B B7 <9G HC @F5B7 9G ;F57 HC B5@± 5B: I @5F: A 57 <± ""69B8 ± HK C D@57 9897 A 5@""± H:F99D@57 9897 A 5@±	8F5K B 7 <97 ?98 9B: 5DDF" A:; 5DDF"			H#@.	
		BH9FDF9H: 9C A 9F 7 HC @F5B7 B: D9F. A 5H9F 5@	E "5" 7 C A A 9BHG			5FIK !&(!, K !A K !K 5!') ?	
	B9LH5GGM	I G98 C B	: B @<			G#9 5	8K; ""BC" F9J
	5DD@7 5HC B	8C B CHG75 @98F5K B:				G7 5 @.%)	K 9 ÷ <H' G<99H('C:)

)

(

&

%

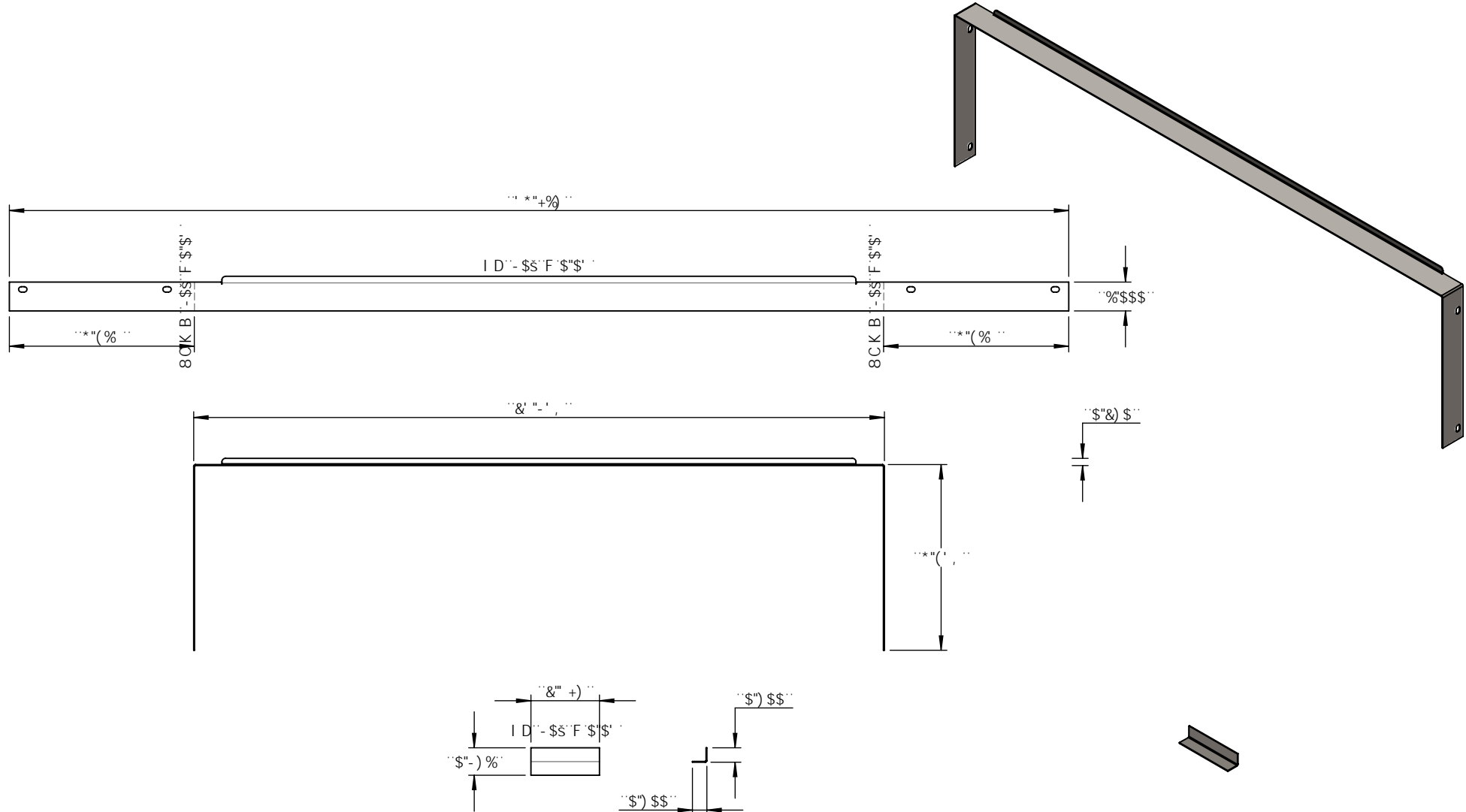

DFC DF 5 FM 5 B 8 7 C B : 8 9 B H 5 @
 H: 9 B: CFA 5HC B 7 C B H 5 B 98 B H: 6
 8F5K B: 6H: 9GC @DFC D9F HVC:
 O B G 9 F H 7 C A D 5 B M B 5 A 9 < 9 F 9 2 " 5 B M
 F 9 D F C 8 1 7 H C B B D 5 F H C F 5 G 5 K < C @
 K H: C I H H: 9 K F H 9 B D 9 F A 6 G C B C:
 O B G 9 F H 7 C A D 5 B M B 5 A 9 < 9 F 9 2 6
 D F C < 6 H 9 8 "

		I B @ G G C H: 9 F K 6 9 G D 9 7 ÷ 9 8.	B 5 A 9	8 5 H 9	&&; 5 I ; 9		
		8 A 9 B G C B G 5 F 9 B B 7 < 9 G H C @ F 5 B 7 9 G : F 5 7 H C B 5 @ ± 5 B: I @ F: A 5 7 < ± 6 9 B 8 ± H C D @ 5 7 9 8 9 7 A 5 @ ± H: F 9 9 D @ 5 7 9 8 9 7 A 5 @ ±	8 F 5 K B			H # @.	
		B H F D F 9 H: 9 C A 9 F F 7 H C @ F 5 B 7 B: D 9 F.	9 B: 5 D D F "		5 F I K ! & (! , K I A K ! K 5 ! ') ?		
		A 5 H F 5 @	A: : 5 D D F "				
	B 9 L H 5 G G M	I G 9 8 C B	E " 5 "		G A 9 8 K ; " " B C "	F 9 J	
	5 D D @ 7 5 H C B	8 C B C H G 7 5 @ 8 F 5 K B:	7 C A A 9 B H G		G 7 5 @ . %)	K 9 ÷ < H '	G < 9 9 H) ' C :)