

ITEM NO.	PART NUMBER	DESCRIPTION	QTY.	CUT
1	TS24-MBK-CFA-PCRD-40W-DIM-35K-OA90"-SPUN HOUSING	SPUN ALUMINUM 0.080"	1	
2	TS24-MBK-CFA-PCRD-40W-DIM-35K-OA90"-CANOPY	SPUN ALUMINUM 0.080"	1	
3	TS24-MBK-CFA-PCRD-40W-DIM-35K-OA90"-MOUNTING BRACKET	ALUMINUM 0.0635"	1	
4	TS24-MBK-CFA-PCRD-40W-DIM-35K-OA90"-LED BRACKET	ALUMINUM 0.0635"	1	
6	TS24-MBK-CFA-PCRD-40W-DIM-35K-OA90"-SPUN BRACKET	SPUN ALUMINUM 0.080"	1	
7	TS24-MBK-CFA-PCRD-40W-DIM-35K-OA90"-SPUN DOOR	SPUN ALUMINUM 0.080"	1	
8	TS24-MBK-CFA-PCRD-40W-DIM-35K-OA90"-ACRYLIC LENS	ACRYLIC	1	
9	.375 BRASS BALL	3/8" BRASS BALL	2	
10	KTLD-25-UV-700-VDIM-LA1	DRIVER	2	
11	AltaiLED_PN1010_RevD	LED	8	

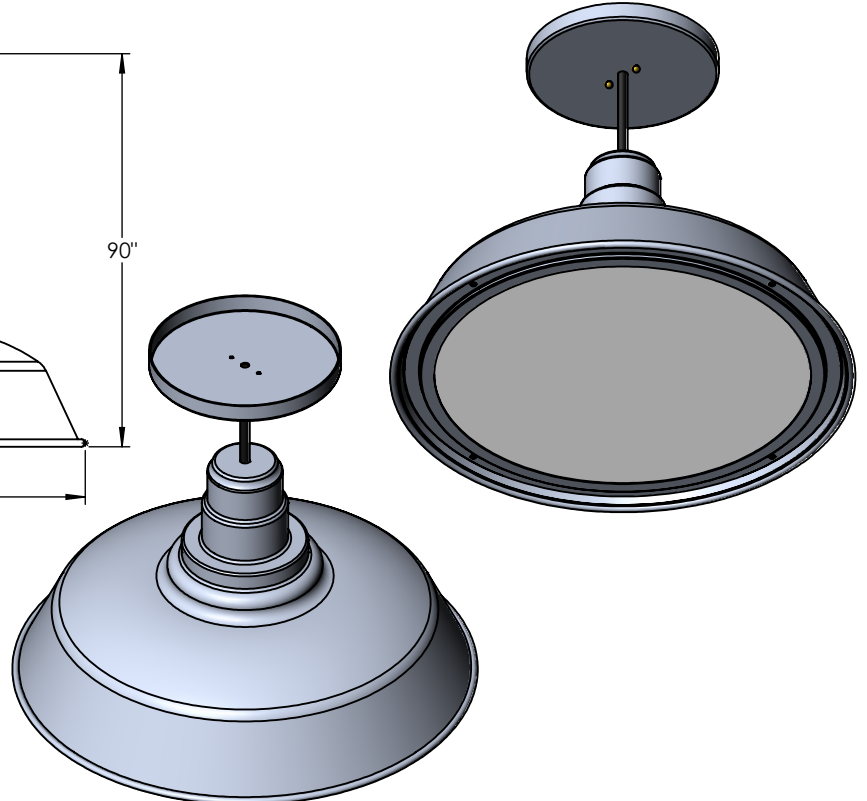

UNLESS OTHERWISE SPECIFIED:		NAME	DATE		
DIMENSIONS ARE IN INCHES		DRAWN		TITLE: TS24-MBK-CFA-PCRD-40W-DIM-35K-OA90"	
TOLERANCES:		CHECKED			
FRACTIONAL ± .003		ENG APPR.			
ANGULAR: MACH ± .01 BEND ±		MFG APPR.			
TWO PLACE DECIMAL ±		Q.A.		SIZE	DWG. NO.
THREE PLACE DECIMAL ±.001		COMMENTS:		A	TICKET 25526
INTERPRET GEOMETRIC TOLERANCING PER:				SCALE: 1:10	WEIGHT:
MATERIAL					SHEET 1 OF 7
FINISH					

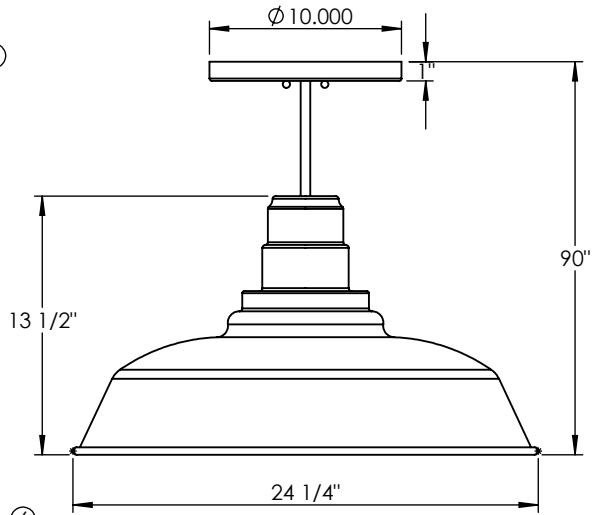
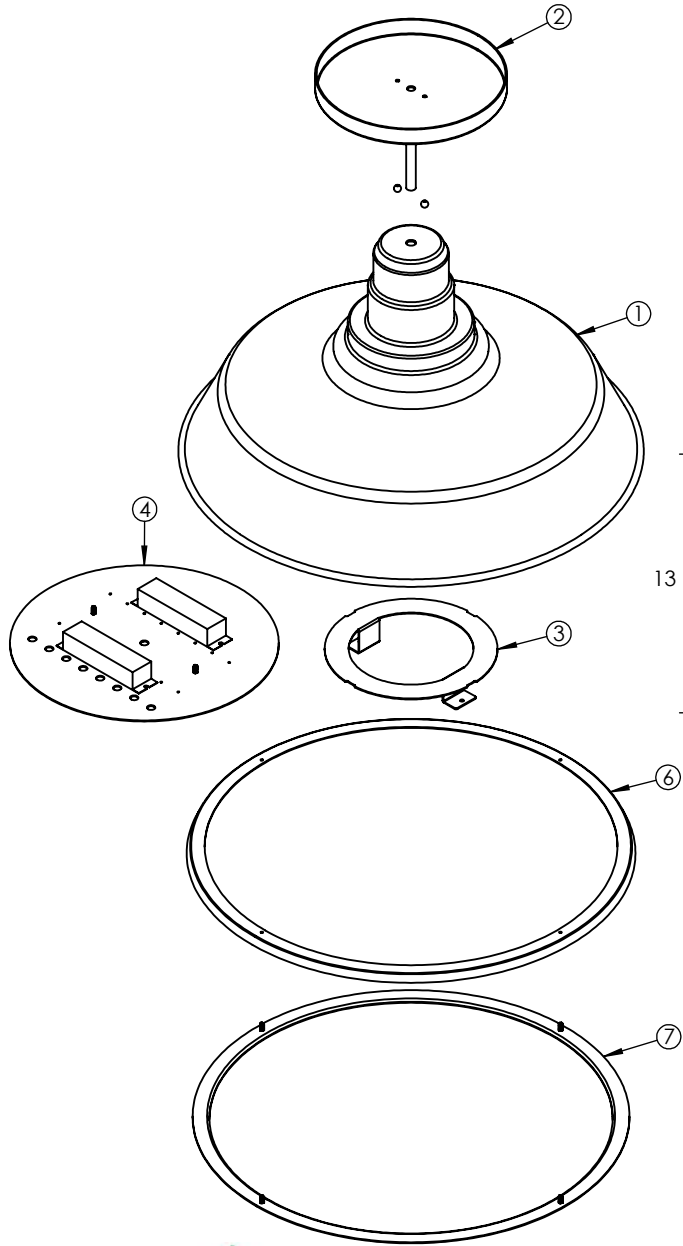

ALL BEND RADIUS .030"

APPLICATION DO NOT SCALE DRAWING

5 4 3 2 1

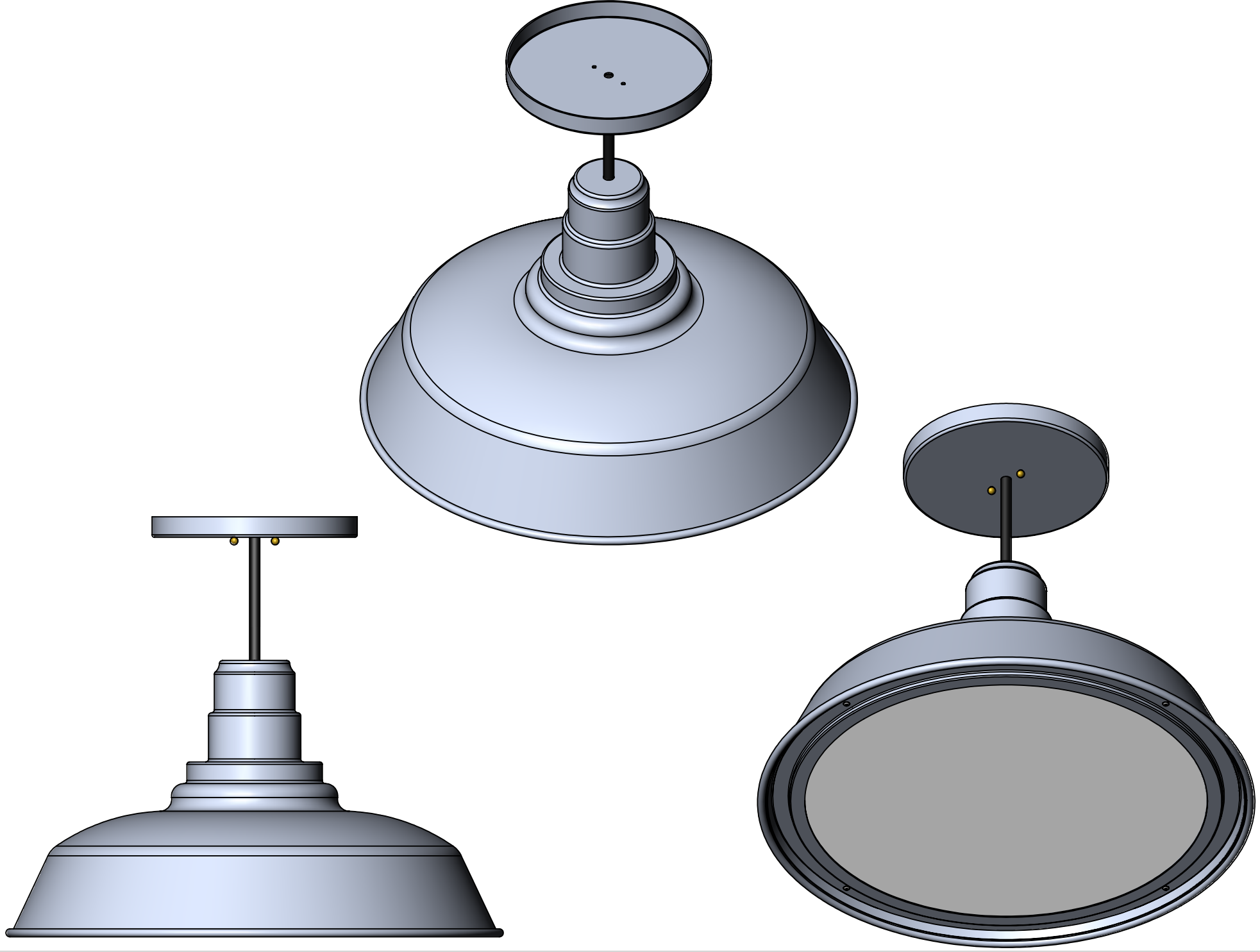

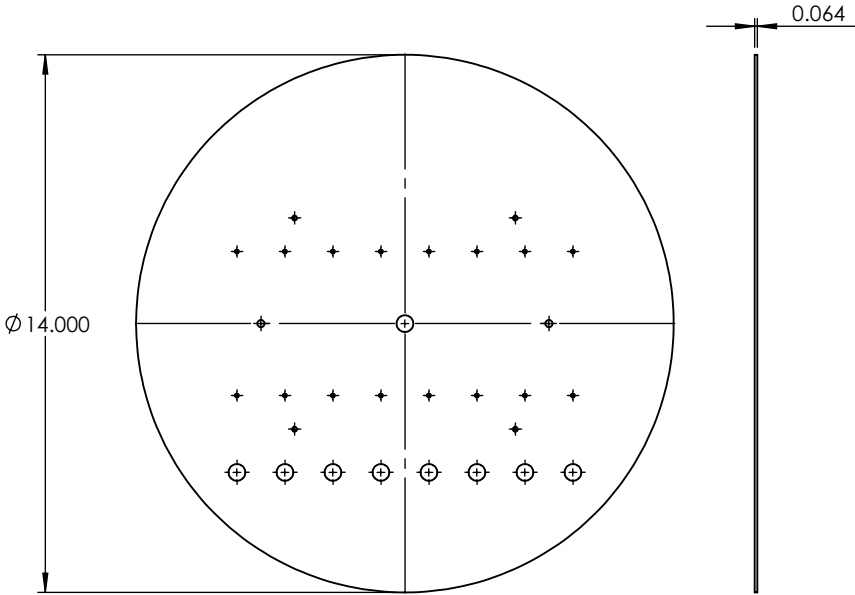
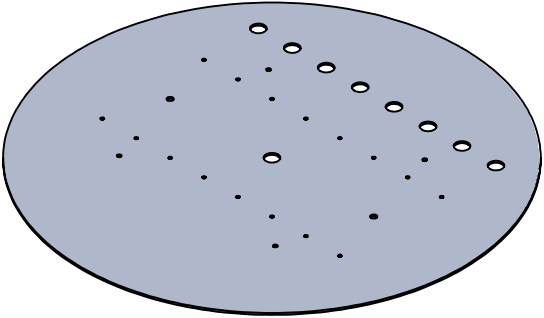

PROPRIETARY AND CONFIDENTIAL
 THE INFORMATION CONTAINED IN THIS DRAWING IS THE SOLE PROPERTY OF <INSERT COMPANY NAME HERE>. ANY REPRODUCTION IN PART OR AS A WHOLE WITHOUT THE WRITTEN PERMISSION OF <INSERT COMPANY NAME HERE> IS PROHIBITED.

		UNLESS OTHERWISE SPECIFIED:		NAME	DATE
		DIMENSIONS ARE IN INCHES	DRAWN		
		TOLERANCES:	CHECKED		
		FRACTIONAL ±	ENG APPR.		
		ANGULAR: MACH ± BEND ±	MFG APPR.		
		TWO PLACE DECIMAL ±	Q.A.		
		THREE PLACE DECIMAL ±	COMMENTS:		
		INTERPRET GEOMETRIC TOLERANCING PER:			
		MATERIAL			
		FINISH			
NEXT ASSY	USED ON				
APPLICATION		DO NOT SCALE DRAWING			

ALUMINUM 0.0635"		
TITLE:		
TS24-MBK-CFA-PCRD-40W-DIM-35K-OA90"		
SIZE	DWG. NO.	REV
A		
SCALE: 1:5	WEIGHT:	SHEET 3 OF 7

5

4

3

2

1

ITEM NO.	PART NUMBER	DESCRIPTION	QTY.
1	TS24-MBK-CFA-PCRD-40W-DIM-35K-OA90"-SPUN HOUSING	SPUN ALUMINUM 0.080"	1

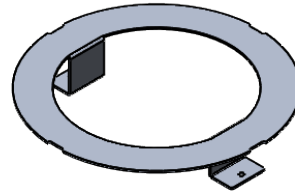
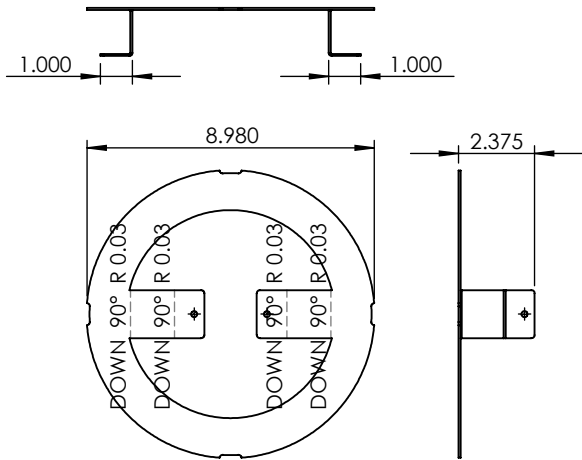
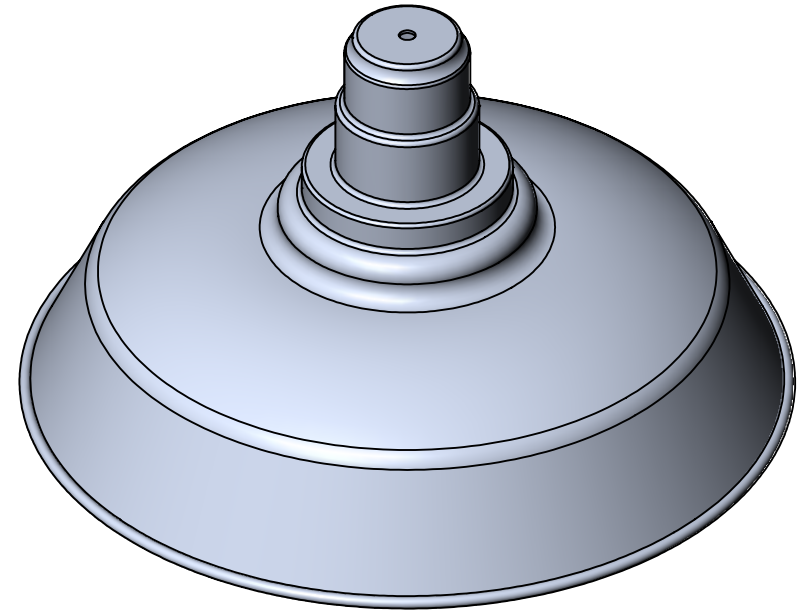
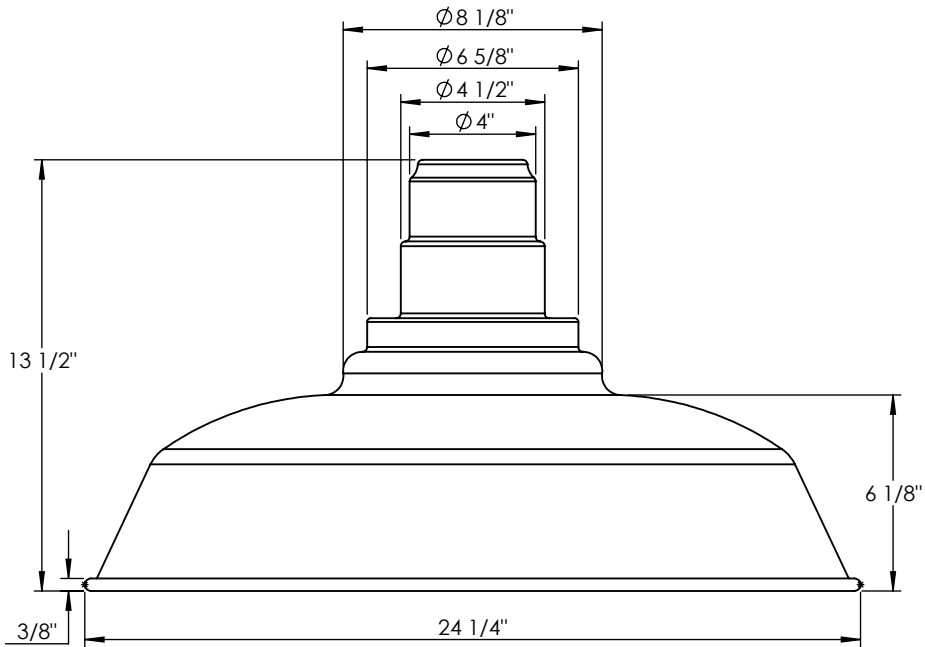

UNLESS OTHERWISE SPECIFIED:

DIMENSIONS ARE IN INCHES
 TOLERANCES:
 FRACTIONAL ±
 ANGULAR: MACH ± BEND ±
 TWO PLACE DECIMAL ±
 THREE PLACE DECIMAL ±

INTERPRET GEOMETRIC
 TOLERANCING PER:

MATERIAL

FINISH

DO NOT SCALE DRAWING

NAME DATE

DRAWN
 CHECKED
 ENG APPR.
 MFG APPR.

Q.A.
 COMMENTS:

SPUN ALUMINUM 0.080"

TITLE:

TS24-MBK-CFA-PCRD-40W-DIM-35K-OA90"

PROPRIETARY AND CONFIDENTIAL
 THE INFORMATION CONTAINED IN THIS
 DRAWING IS THE SOLE PROPERTY OF
 <INSERT COMPANY NAME HERE>. ANY
 REPRODUCTION IN PART OR AS A WHOLE
 WITHOUT THE WRITTEN PERMISSION OF
 <INSERT COMPANY NAME HERE> IS
 PROHIBITED.

NEXT ASSY	USED ON
APPLICATION	

SIZE A	DWG. NO.	REV
SCALE: 1:6	WEIGHT:	SHEET 4 OF 7

ITEM NO.	PART NUMBER	DESCRIPTION	QTY.
1	TS24-MBK-CFA-PCRD-40W-DIM-35K-OA90"-CANOPY	SPUN ALUMINUM 0.080"	1

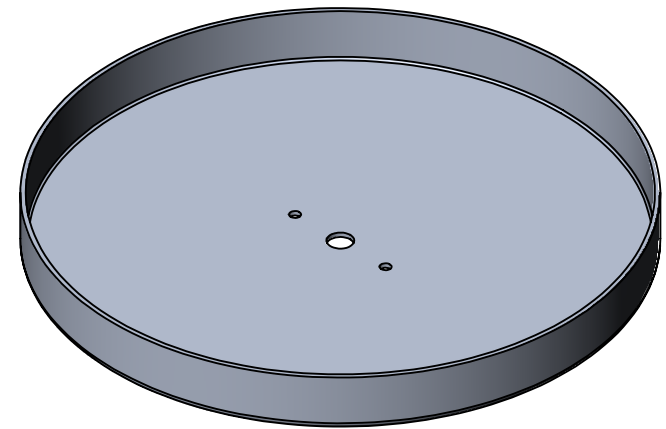
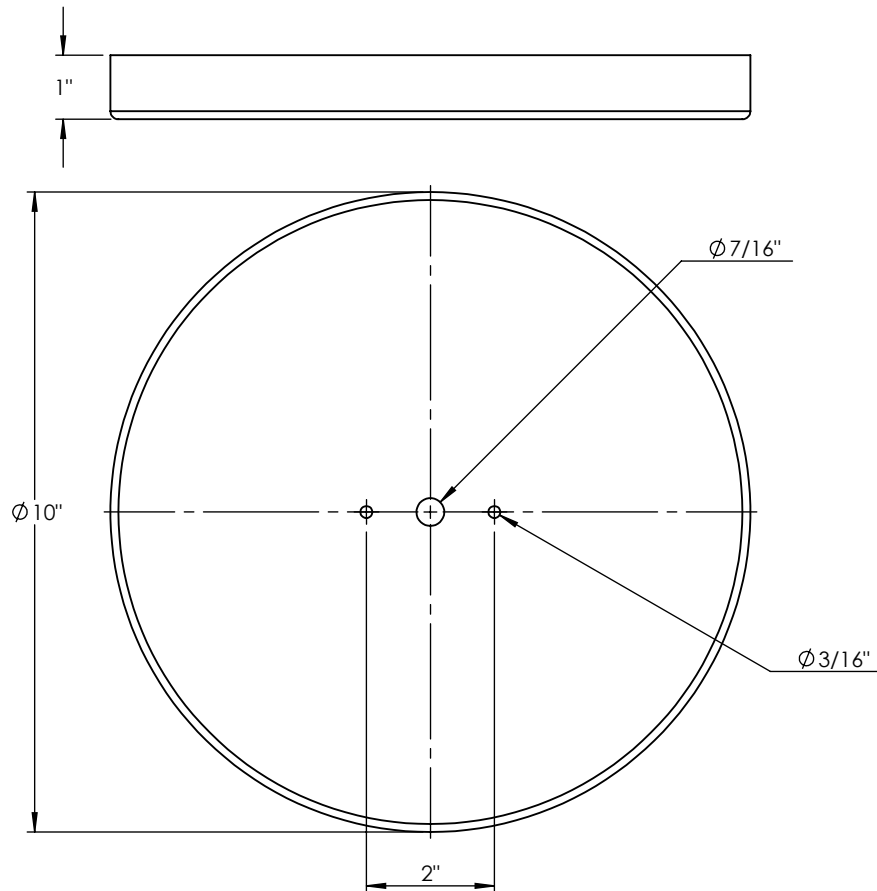

PROPRIETARY AND CONFIDENTIAL
 THE INFORMATION CONTAINED IN THIS DRAWING IS THE SOLE PROPERTY OF <INSERT COMPANY NAME HERE>. ANY REPRODUCTION IN PART OR AS A WHOLE WITHOUT THE WRITTEN PERMISSION OF <INSERT COMPANY NAME HERE> IS PROHIBITED.

		UNLESS OTHERWISE SPECIFIED:		NAME	DATE
		DIMENSIONS ARE IN INCHES	DRAWN		
		TOLERANCES:	CHECKED		
		FRACTIONAL ±	ENG APPR.		
		ANGULAR: MACH ± BEND ±	MFG APPR.		
		TWO PLACE DECIMAL ±	Q.A.		
		THREE PLACE DECIMAL ±	COMMENTS:		
		INTERPRET GEOMETRIC TOLERANCING PER:			
		MATERIAL			
		FINISH			
NEXT ASSY	USED ON				
APPLICATION		DO NOT SCALE DRAWING			

SPUN ALUMINUM 0.080"		
TITLE:		
TS24-MBK-CFA-PCRD-40W-DIM-35K-OA90"		
SIZE	DWG. NO.	REV
A		
SCALE: 1:3	WEIGHT:	SHEET 5 OF 7

ITEM NO.	PART NUMBER	DESCRIPTION	QTY.
1	TS24-MBK-CFA-PCRD-40W-DIM-35K-OA90"-SPUN BRACKET	SPUN ALUMINUM 0.080"	1

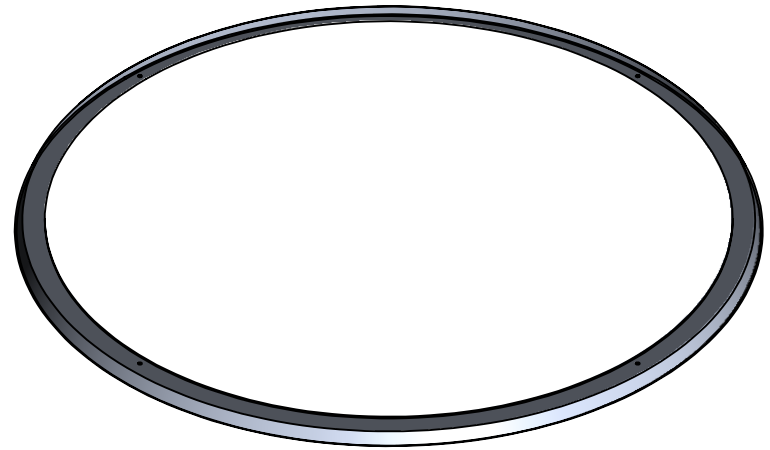
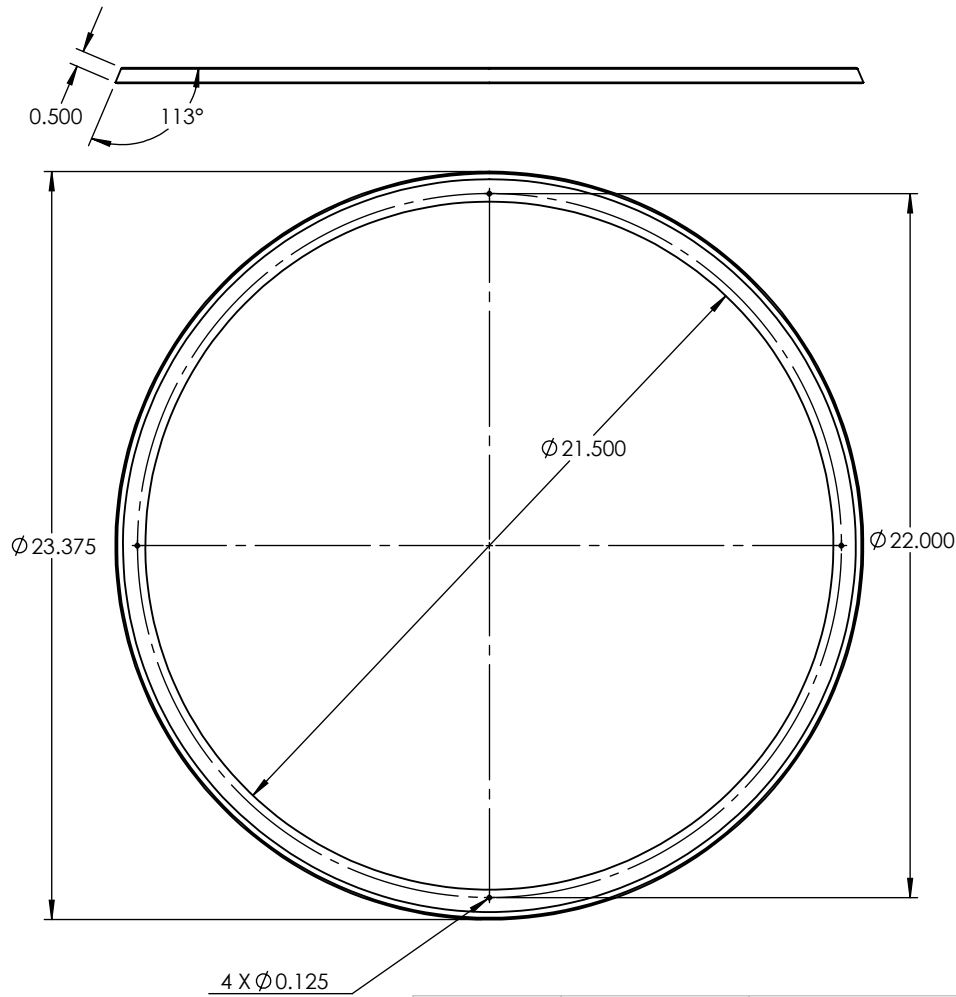

PROPRIETARY AND CONFIDENTIAL
 THE INFORMATION CONTAINED IN THIS DRAWING IS THE SOLE PROPERTY OF <INSERT COMPANY NAME HERE>. ANY REPRODUCTION IN PART OR AS A WHOLE WITHOUT THE WRITTEN PERMISSION OF <INSERT COMPANY NAME HERE> IS PROHIBITED.

		UNLESS OTHERWISE SPECIFIED:		NAME	DATE
		DIMENSIONS ARE IN INCHES	DRAWN		
		TOLERANCES:	CHECKED		
		FRACTIONAL ±	ENG APPR.		
		ANGULAR: MACH ± BEND ±	MFG APPR.		
		TWO PLACE DECIMAL ±	Q.A.		
		THREE PLACE DECIMAL ±	COMMENTS:		
		INTERPRET GEOMETRIC TOLERANCING PER:			
		MATERIAL			
NEXT ASSY	USED ON	FINISH			
	APPLICATION	DO NOT SCALE DRAWING			

SPUN ALUMINUM 0.080"		
TITLE:		
TS24-MBK-CFA-PCRD-40W-DIM-35K-OA90"		
SIZE	DWG. NO.	REV
A		
SCALE: 1:6	WEIGHT:	SHEET 6 OF 7

5

4

3

2

1

ITEM NO.	PART NUMBER	DESCRIPTION	QTY.
1	TS24-MBK-CFA-PCRD-40W-DIM-35K-OA90"-SPUN DOOR	SPUN ALUMINUM 0.080"	1

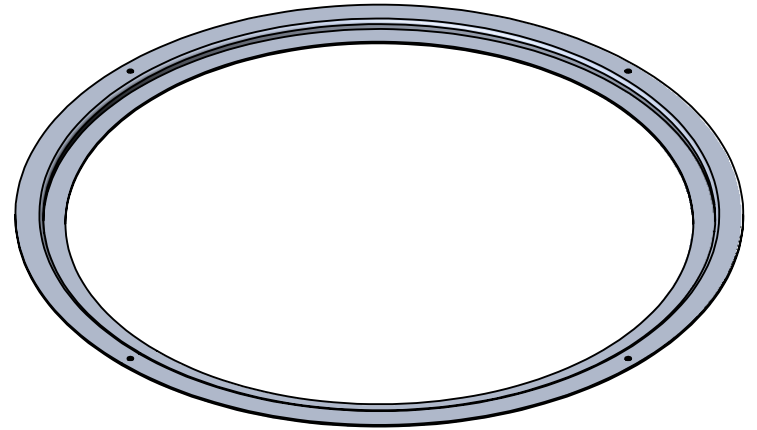
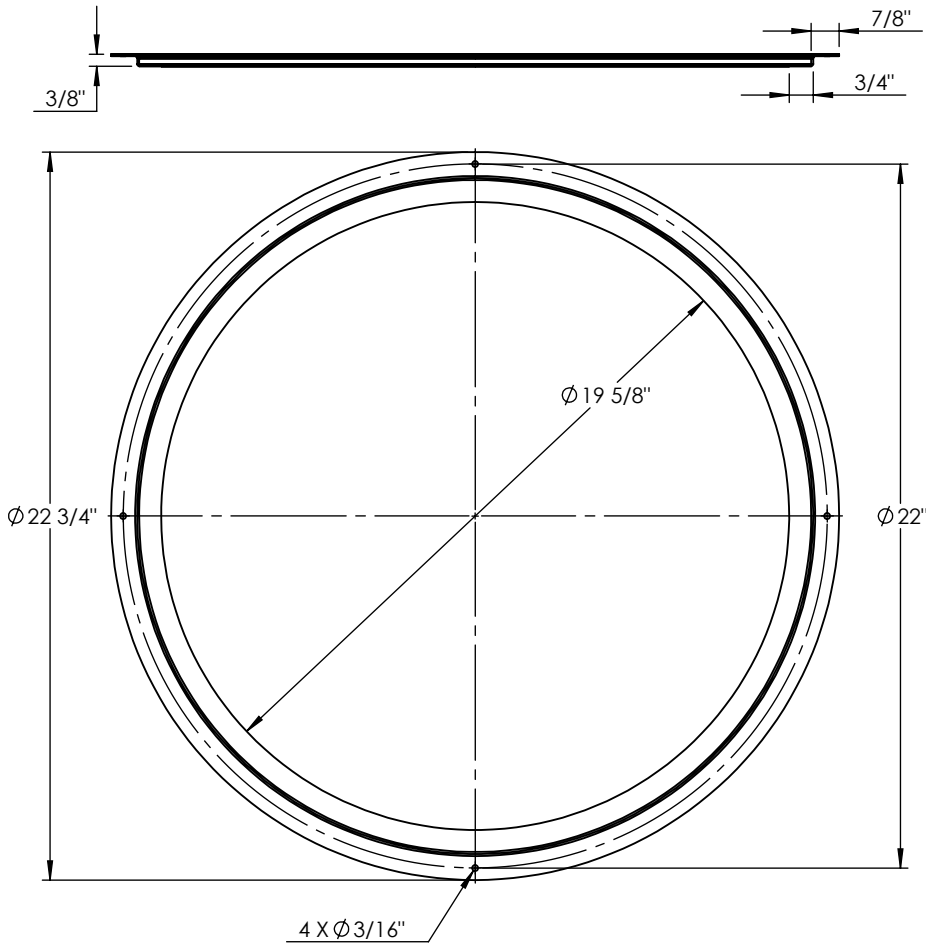

PROPRIETARY AND CONFIDENTIAL
 THE INFORMATION CONTAINED IN THIS DRAWING IS THE SOLE PROPERTY OF <INSERT COMPANY NAME HERE>. ANY REPRODUCTION IN PART OR AS A WHOLE WITHOUT THE WRITTEN PERMISSION OF <INSERT COMPANY NAME HERE> IS PROHIBITED.

		UNLESS OTHERWISE SPECIFIED:	NAME	DATE	SPUN ALUMINUM 0.080"	
		DIMENSIONS ARE IN INCHES	DRAWN		TITLE:	
		TOLERANCES:	CHECKED		TS24-MBK-CFA-PCRD-40W-DIM-35K-OA90"	
		FRACTIONAL ±	ENG APPR.		SIZE DWG. NO. REV	
		ANGULAR: MACH ± BEND ±	MFG APPR.		A	
		TWO PLACE DECIMAL ±	Q.A.		SCALE: 1:6 WEIGHT: SHEET 7 OF 7	
		THREE PLACE DECIMAL ±	COMMENTS:			
		INTERPRET GEOMETRIC TOLERANCING PER:				
		MATERIAL				
NEXT ASSY	USED ON	FINISH				
APPLICATION		DO NOT SCALE DRAWING				