

ITEM NO.	PART NUMBER	DESCRIPTION	QTY.	CUT
1	INDVRT24"-WBB-18W-MN-WF-41K-FRAME	22 GAUGE	1	
2	INDVRT24"-WBB-18W-MN-WF-41K-FRAME TAB	22 GAUGE	4	
3	INDVRT24"-WBB-18W-MN-WF-41K-DRIVER BRACKET	22 GAUGE	1	
4	INDVRT24"-WBB-18W-MN-WF-41K-FIREPLATE	22 GAUGE	1	
5	INDVRT24"-WBB-18W-MN-WF-41K-TUBE DOOR	22 GAUGE	1	
6	INDVRT24"-WBB-18W-MN-WF-41K-ALUMINUM ACCENT 1	ALUMINUM 0.0635"	1	
7	INDVRT24"-WBB-18W-MN-WF-41K-ALUMINUM ACCENT 2	ALUMINUM 0.0635"	1	
8	INDVRT24"-WBB-18W-MN-WF-41K-LED BRACKET	ALUMINUM 0.0635"	1	
9	INDVRT24"-WBB-18W-MN-WF-41K-LED PLATE	ALUMINUM 0.0635"	2	
10	INDVRT24"-WBB-18W-MN-WF-41K-ACRYLIC	ACRYLIC	1	
11	Espen VEL19070MVH-1	DRIVER	1	
12	AlfaLED PN107B-11-SS	LED	2	

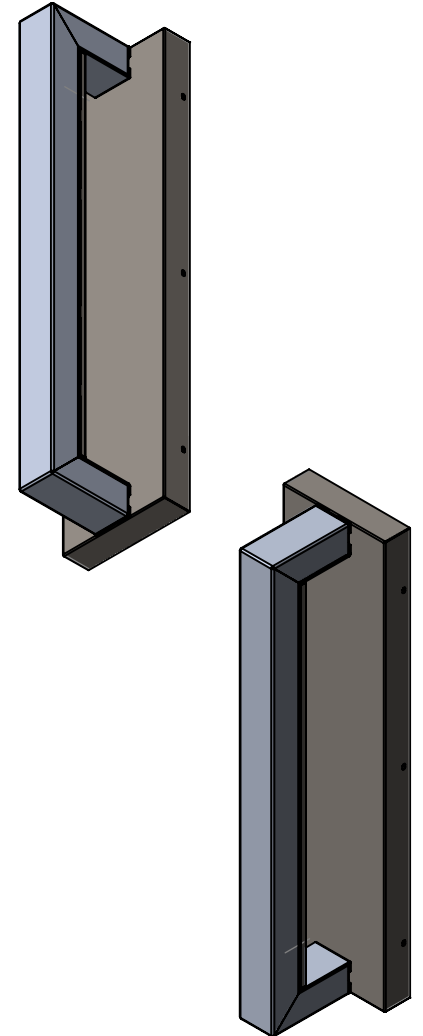
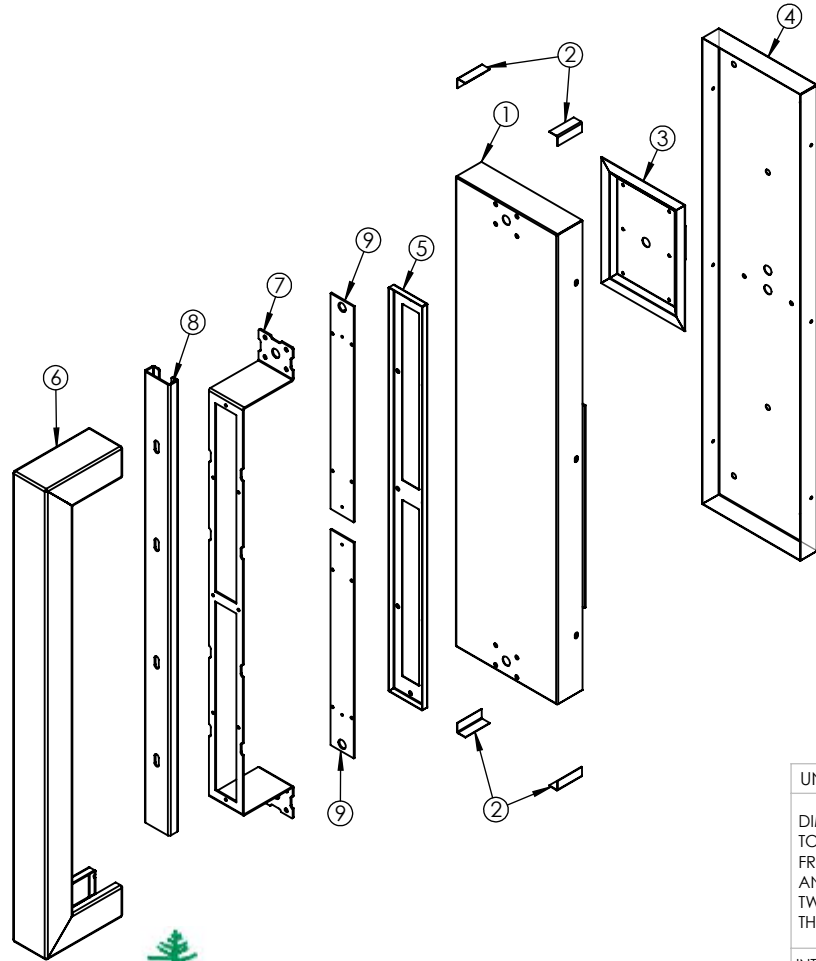

ALL BEND RADIUS .030"

APPLICATION

DO NOT SCALE DRAWING

UNLESS OTHERWISE SPECIFIED:

DIMENSIONS ARE IN INCHES
TOLERANCES:
FRACTIONAL ± .003
ANGULAR: MACH ± .01 BEND ±
TWO PLACE DECIMAL ±
THREE PLACE DECIMAL ±.001

INTERPRET GEOMETRIC
TOLERANCING PER:

MATERIAL

FINISH

NAME

DATE

DRAWN

CHECKED

ENG APPR.

MFG APPR.

Q.A.

COMMENTS:

TITLE:

INDVRT24"-WBB-18W-MN-WF-41K

SIZE DWG. NO.

REV

A TICKET 25617

SCALE: 1:8

WEIGHT:

SHEET 1 OF 7

5

4

3

2

1

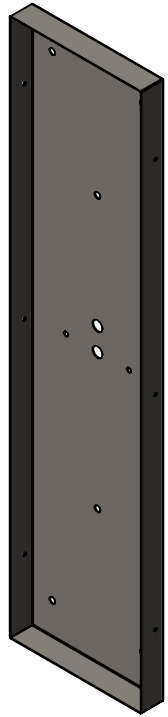
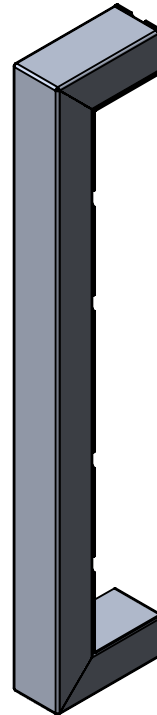
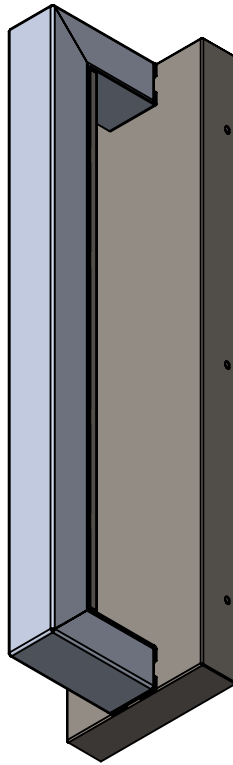
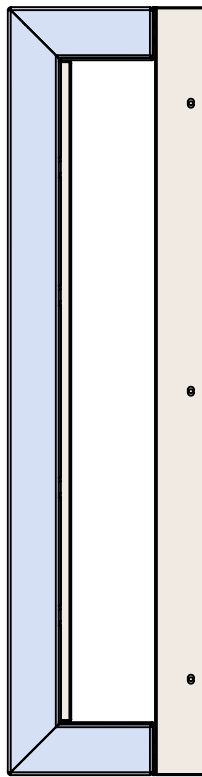
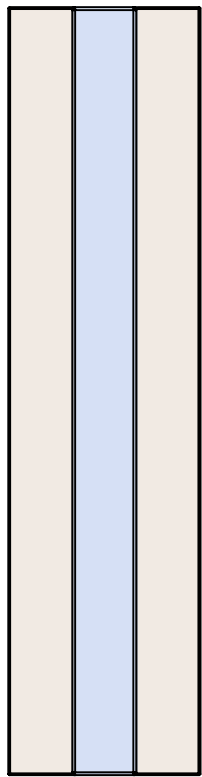

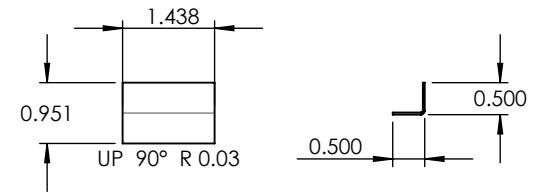
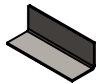
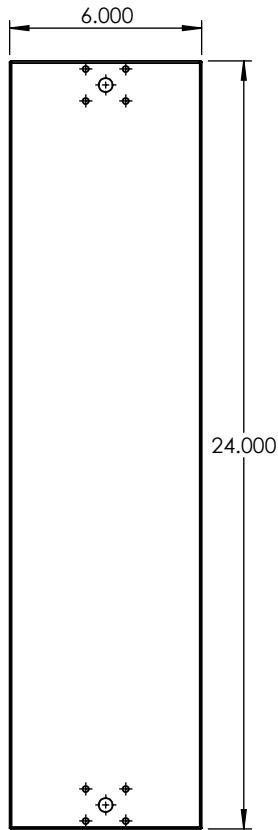
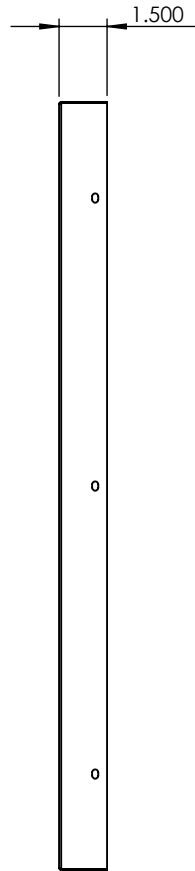
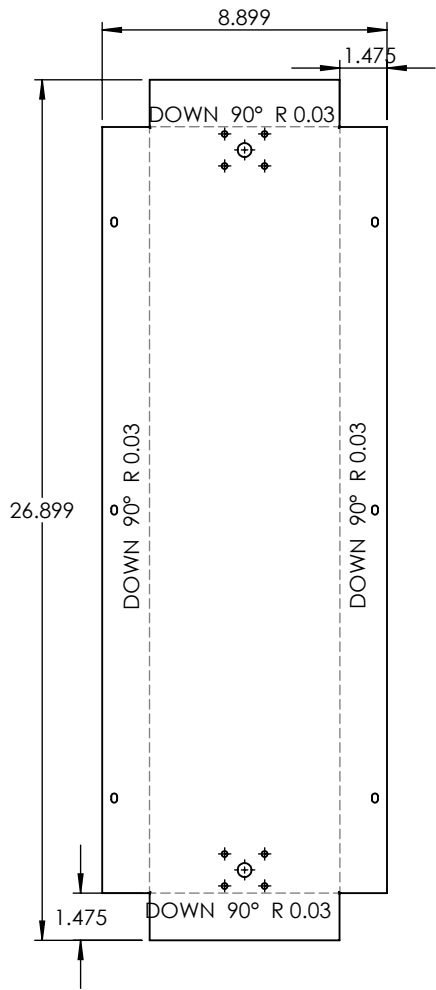

UNLESS OTHERWISE SPECIFIED:

DIMENSIONS ARE IN INCHES
 TOLERANCES:
 FRACTIONAL ±
 ANGULAR: MACH ± BEND ±
 TWO PLACE DECIMAL ±
 THREE PLACE DECIMAL ±

INTERPRET GEOMETRIC
 TOLERANCING PER:

MATERIAL

FINISH

DO NOT SCALE DRAWING

NAME

DATE

22 GAUGE

TITLE:

INDVRT24"-WBB-18W-MN-WF-41K

SIZE
A

DWG. NO.

REV

SCALE: 1:6

WEIGHT:

SHEET 3 OF 7

PROPRIETARY AND CONFIDENTIAL
 THE INFORMATION CONTAINED IN THIS
 DRAWING IS THE SOLE PROPERTY OF
 <INSERT COMPANY NAME HERE>. ANY
 REPRODUCTION IN PART OR AS A WHOLE
 WITHOUT THE WRITTEN PERMISSION OF
 <INSERT COMPANY NAME HERE> IS
 PROHIBITED.

NEXT ASSY

USED ON

APPLICATION

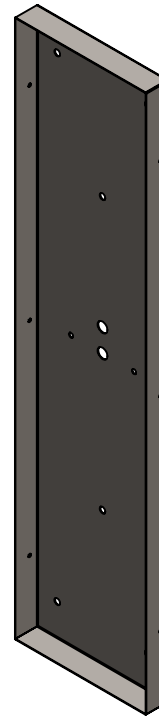
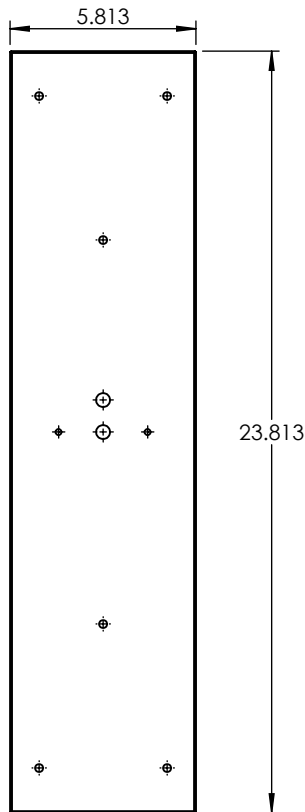
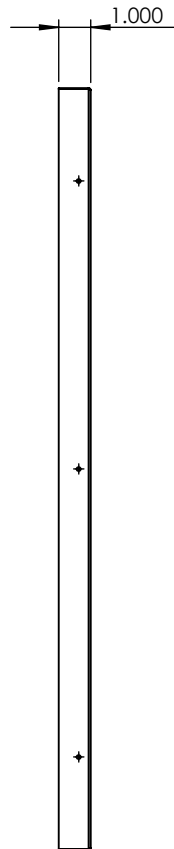
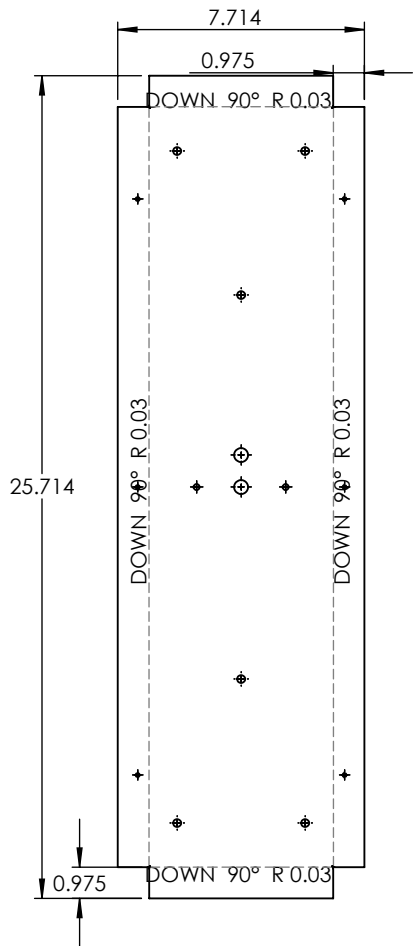

PROPRIETARY AND CONFIDENTIAL
 THE INFORMATION CONTAINED IN THIS DRAWING IS THE SOLE PROPERTY OF <INSERT COMPANY NAME HERE>. ANY REPRODUCTION IN PART OR AS A WHOLE WITHOUT THE WRITTEN PERMISSION OF <INSERT COMPANY NAME HERE> IS PROHIBITED.

NEXT ASSY	USED ON
APPLICATION	

UNLESS OTHERWISE SPECIFIED:
DIMENSIONS ARE IN INCHES
TOLERANCES:
FRACTIONAL ±
ANGULAR: MACH ± BEND ±
TWO PLACE DECIMAL ±
THREE PLACE DECIMAL ±
INTERPRET GEOMETRIC TOLERANCING PER:
MATERIAL
FINISH
DO NOT SCALE DRAWING

	NAME	DATE
DRAWN		
CHECKED		
ENG APPR.		
MFG APPR.		
Q.A.		
COMMENTS:		

22 GAUGE		
TITLE:		
INDVRT24"-WBB-18W-MN-WF-41K		
SIZE	DWG. NO.	REV
A		
SCALE: 1:6	WEIGHT:	SHEET 4 OF 7

5

4

3

2

1

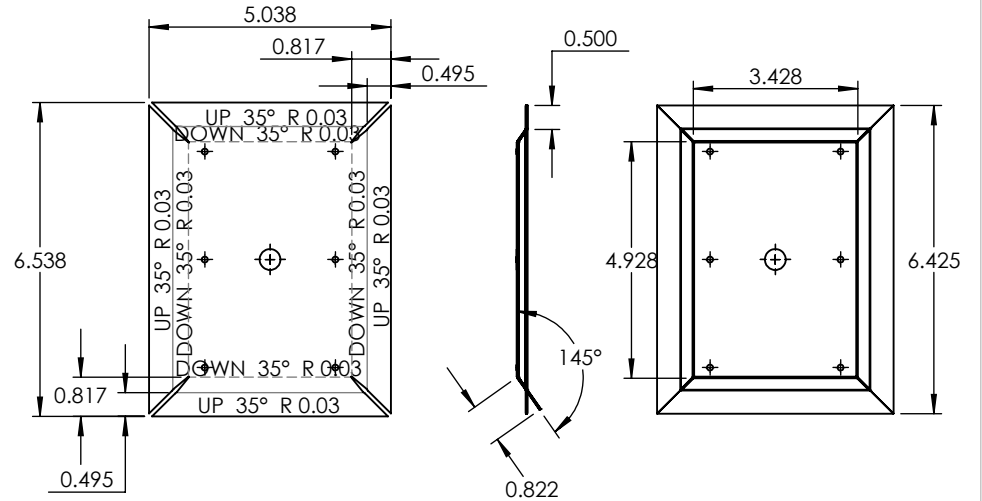
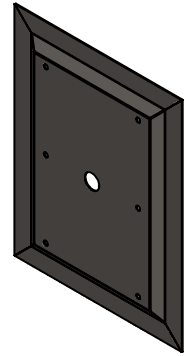
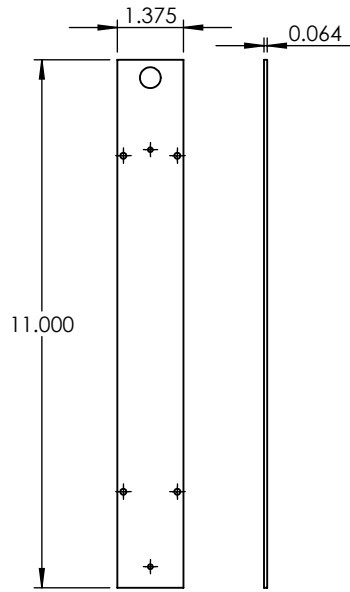
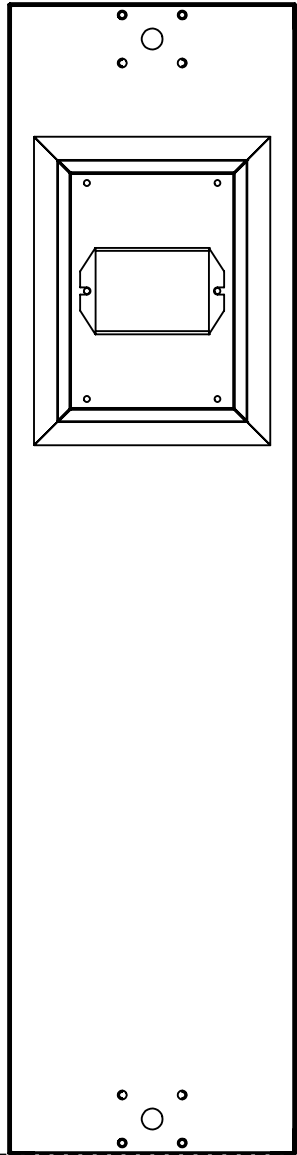

UNLESS OTHERWISE SPECIFIED:		NAME	DATE	22 GAUGE		
DIMENSIONS ARE IN INCHES TOLERANCES: FRACTIONAL ± ANGULAR: MACH ± BEND ± TWO PLACE DECIMAL ± THREE PLACE DECIMAL ±		DRAWN				TITLE:
INTERPRET GEOMETRIC TOLERANCING PER:		CHECKED		INDVRT24"-WBB-18W-MN-WF-41K		
MATERIAL		ENG APPR.				
FINISH		MFG APPR.		SIZE	DWG. NO.	REV
NEXT ASSY	USED ON	Q.A.		A		
APPLICATION		COMMENTS:			SCALE: 1:4	WEIGHT:
DO NOT SCALE DRAWING						

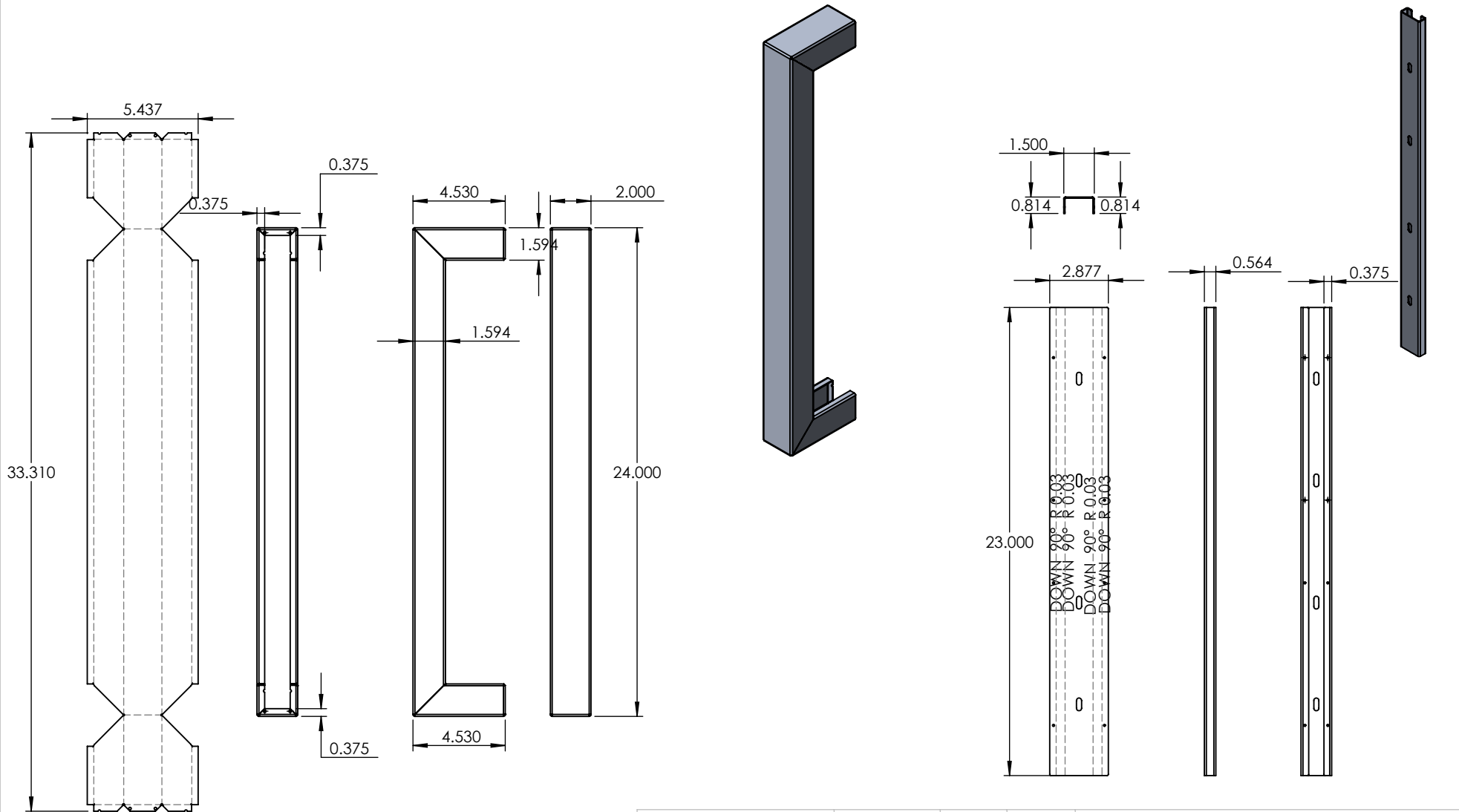

UNLESS OTHERWISE SPECIFIED:		NAME	DATE	ALUMINUM 0.0635"	
DIMENSIONS ARE IN INCHES TOLERANCES: FRACTIONAL ± ANGULAR: MACH ± BEND ± TWO PLACE DECIMAL ± THREE PLACE DECIMAL ±		DRAWN			
INTERPRET GEOMETRIC TOLERANCING PER:		CHECKED		INDVRT24"-WBB-18W-MN-WF-41K	
		ENG APPR.		SIZE	DWG. NO.
MATERIAL		MFG APPR.		REV	
FINISH		Q.A.		SCALE: 1:7	
DO NOT SCALE DRAWING		COMMENTS:		WEIGHT:	SHEET 6 OF 7

PROPRIETARY AND CONFIDENTIAL
THE INFORMATION CONTAINED IN THIS DRAWING IS THE SOLE PROPERTY OF <INSERT COMPANY NAME HERE>. ANY REPRODUCTION IN PART OR AS A WHOLE WITHOUT THE WRITTEN PERMISSION OF <INSERT COMPANY NAME HERE> IS PROHIBITED.

NEXT ASSY	USED ON
APPLICATION	

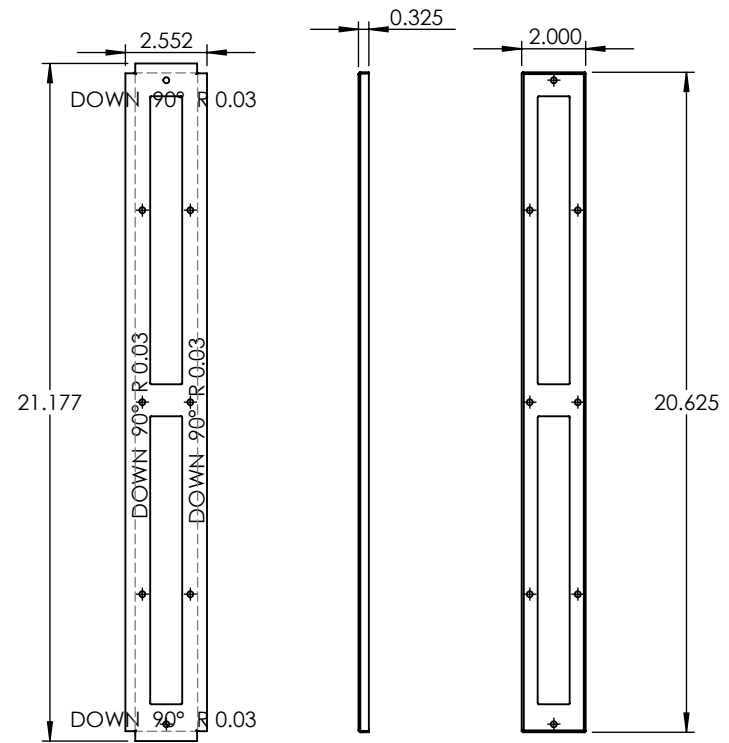
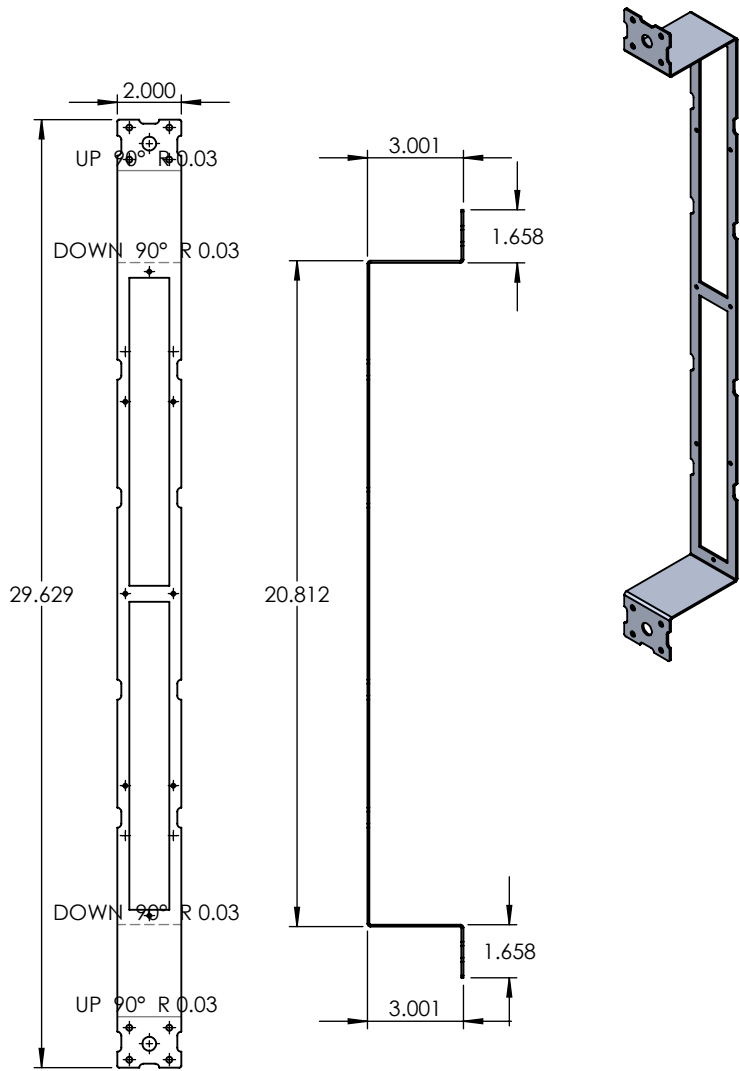

UNLESS OTHERWISE SPECIFIED: DIMENSIONS ARE IN INCHES TOLERANCES: FRACTIONAL ± ANGULAR: MACH ± BEND ± TWO PLACE DECIMAL ± THREE PLACE DECIMAL ±	DRAWN	NAME	DATE	22 GAUGE	
	CHECKED				
	ENG APPR.			INDVRT24"-WBB-18W-MN-WF-41K	
	MFG APPR.			SIZE	REV
INTERPRET GEOMETRIC TOLERANCING PER:	Q.A.			A	
MATERIAL	COMMENTS:			SCALE: 1:6	WEIGHT:
FINISH					SHEET 7 OF 7
NEXT ASSY	USED ON				
APPLICATION	DO NOT SCALE DRAWING				

PROPRIETARY AND CONFIDENTIAL
THE INFORMATION CONTAINED IN THIS DRAWING IS THE SOLE PROPERTY OF <INSERT COMPANY NAME HERE>. ANY REPRODUCTION IN PART OR AS A WHOLE WITHOUT THE WRITTEN PERMISSION OF <INSERT COMPANY NAME HERE> IS PROHIBITED.