

ITEM NO.	PART NUMBER	DESCRIPTION	QTY.	CUT
1	YSHP-PST-60W-TVP-A-13AB3-RD-AL-X442-30K- CUSTOM POST FITTER	3" ALUMINUM POST FITTER	1	
2	YSHP-PST-60W-TVP-A-13AB3-RD-AL-X442-30K-2" SPACER BRACKET	ALUMINUM 0.250" PLATE	2	
3	YSHP-PST-60W-TVP-A-13AB3-RD-AL-X442-30K-2" CYLINDER SPACER	3" ALUMINUM TUBE POST	1	
4	YSHP-PST-60W-TVP-A-13AB3-RD-AL-X442-30K-3" CYLINDER POST	3" ALUMINUM TUBE	1	
5	YSHP-PST-60W-TVP-A-13AB3-RD-AL-X442-30K-CAST BASE	CAST ALUMINUM	1	
6	YSHP-PST-60W-TVP-A-13AB3-RD-AL-X442-30K-SPUN BOTTOM	SPUN ALUMINUM 0.080"	1	
7	YSHP-PST-60W-TVP-A-13AB3-RD-AL-X442-30K-SPUN BOTTOM PLATE	ALUMINUM 0.250" PLATE	1	
8	YSHP-PST-60W-TVP-A-13AB3-RD-AL-X442-30K-TUBE BRACKET	22 GAUGE	1	
9	YSHP-PST-60W-TVP-A-13AB3-RD-AL-X442-30K-TOP LENS SPACER	SPUN ALUMINUM 0.080"	1	
10	YSHP-PST-60W-TVP-A-13AB3-RD-AL-X442-30K-SPUN SHADE	SPUN ALUMINUM 0.080"	1	
11	YSHP-PST-60W-TVP-A-13AB3-RD-AL-X442-30K-TOP SPUN ACCENTS	SPUN ALUMINUM 0.080"	1	
12	YSHP-PST-60W-TVP-A-13AB3-RD-AL-X442-30K-STRAP 1	ALUMINUM 0.125" PLATE	3	
13	YSHP-PST-60W-TVP-A-13AB3-RD-AL-X442-30K-STRAP 2	SPUN ALUMINUM 0.080"	3	
14	YSHP-PST-60W-TVP-A-13AB3-RD-AL-X442-30K-LED TUBE	1" SQUARE ALUMINUM TUBE	1	
15	YSHP-PST-60W-TVP-A-13AB3-RD-AL-X442-30K-0.625 INCH TUBE	1/2" ROUND ALUMINUM TUBE	1	
16	YSHP-PST-60W-TVP-A-13AB3-RD-AL-X442-30K-ACRYLIC	ACRYLIC	1	
17	YSHP-PST-60W-TVP-A-13AB3-RD-AL-X442-30K-NIPPLE	NIPPLE	1	
18	YSHP-PST-60W-TVP-A-13AB3-RD-AL-X442-30K-DRIVER BRACKET	ALUMINUM 0.0635"	1	
19	BULLET ACCENT	BRASS ACCENT	1	
20	ESPEN VEL29070MVH-1	DRIVER	2	
21	Altailed_PN1004RevD	LED	8	

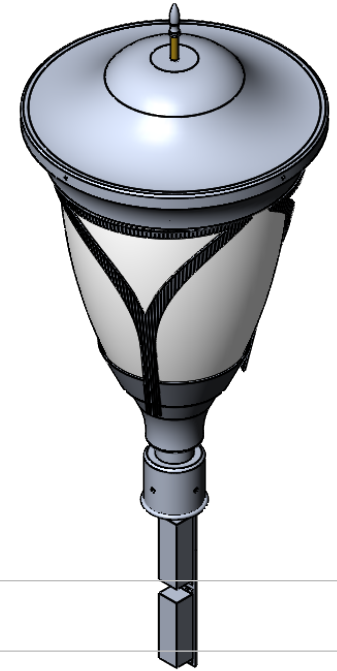
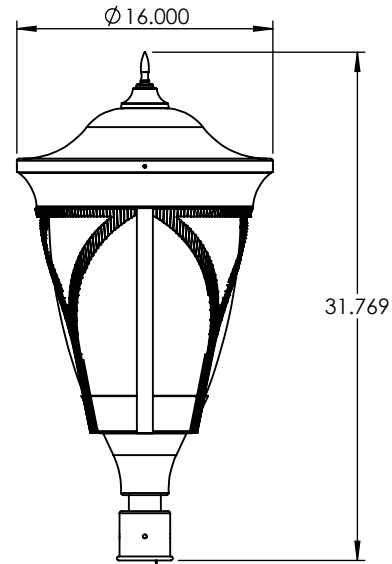
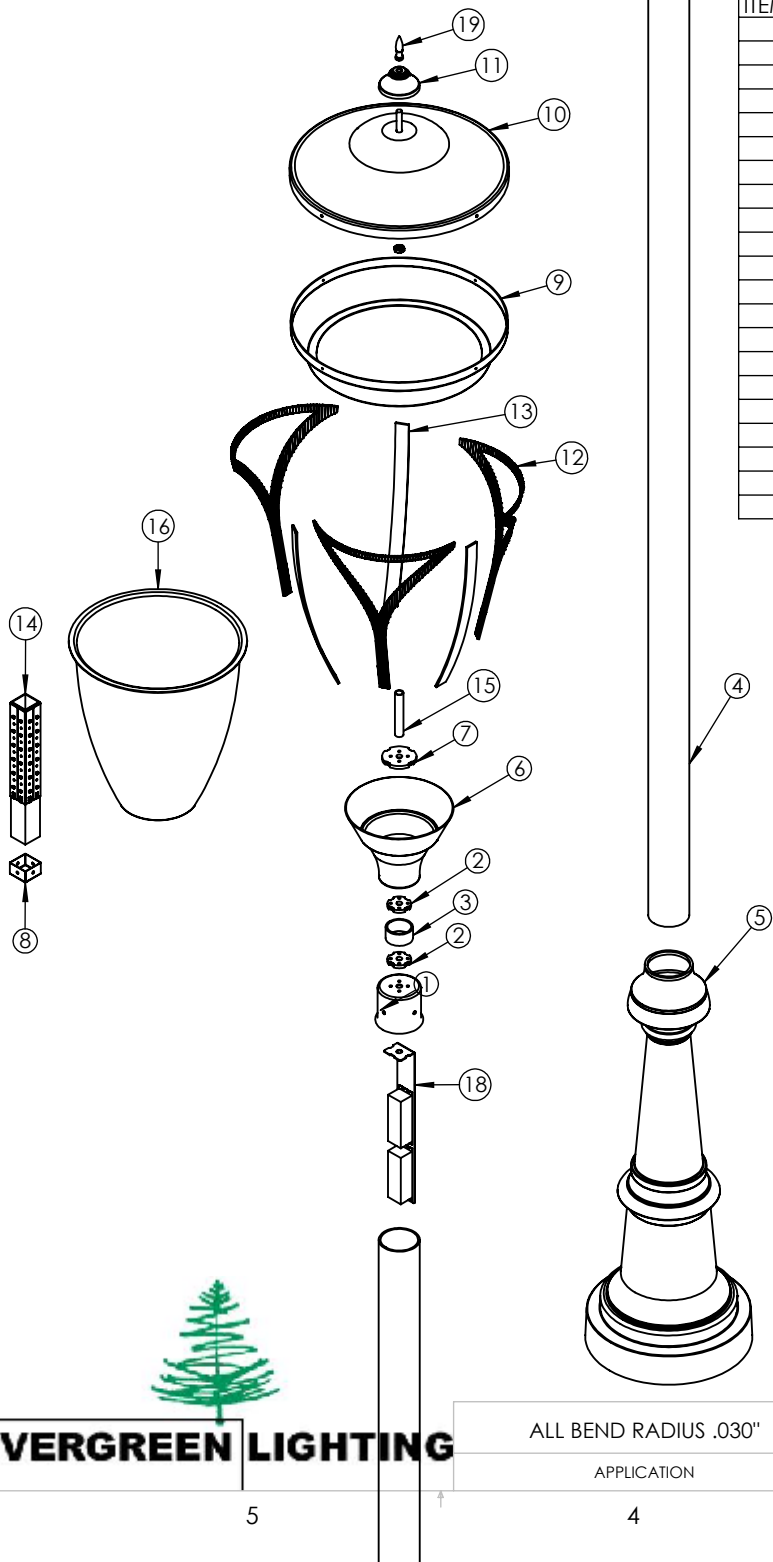

UNLESS OTHERWISE SPECIFIED:

DIMENSIONS ARE IN INCHES
 TOLERANCES:
 FRACTIONAL ± .003
 ANGULAR: MACH ± .01 BEND ±
 TWO PLACE DECIMAL ±
 THREE PLACE DECIMAL ± .001

INTERPRET GEOMETRIC
 TOLERANCING PER:
 MATERIAL

FINISH

NAME	DATE
DRAWN	
CHECKED	
ENG APPR.	
MFG APPR.	
Q.A.	

COMMENTS:

TITLE:

YSHP-PST-60W-TVP-A-13AB3-RD-AL-X442-3

SIZE DWG. NO. REV
A TICKET 25677

SCALE: 1:14 WEIGHT: SHEET 1 OF 12

EVERGREEN LIGHTING

ALL BEND RADIUS .030"

APPLICATION

DO NOT SCALE DRAWING

5

4

3

2

1



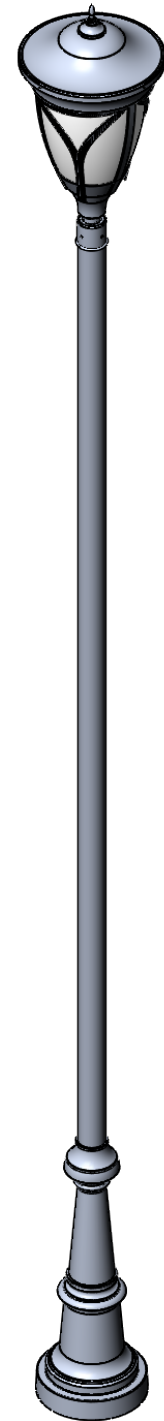
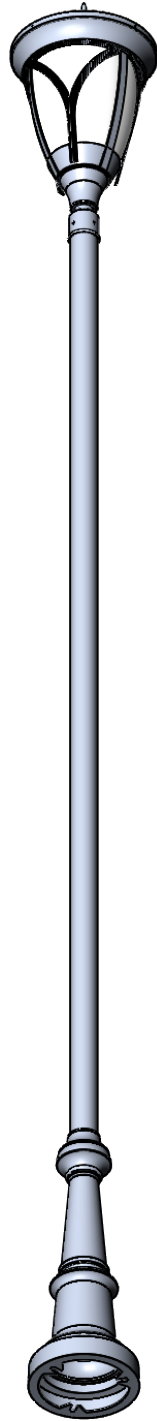
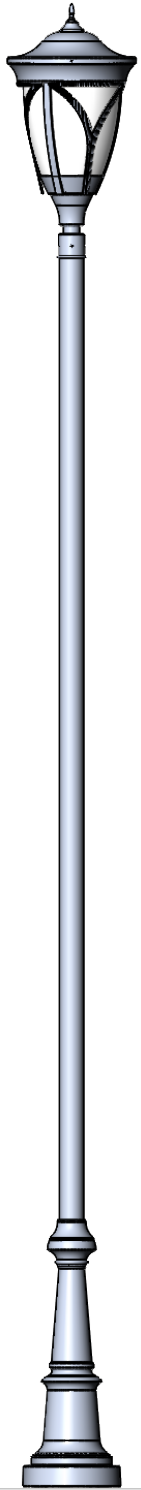

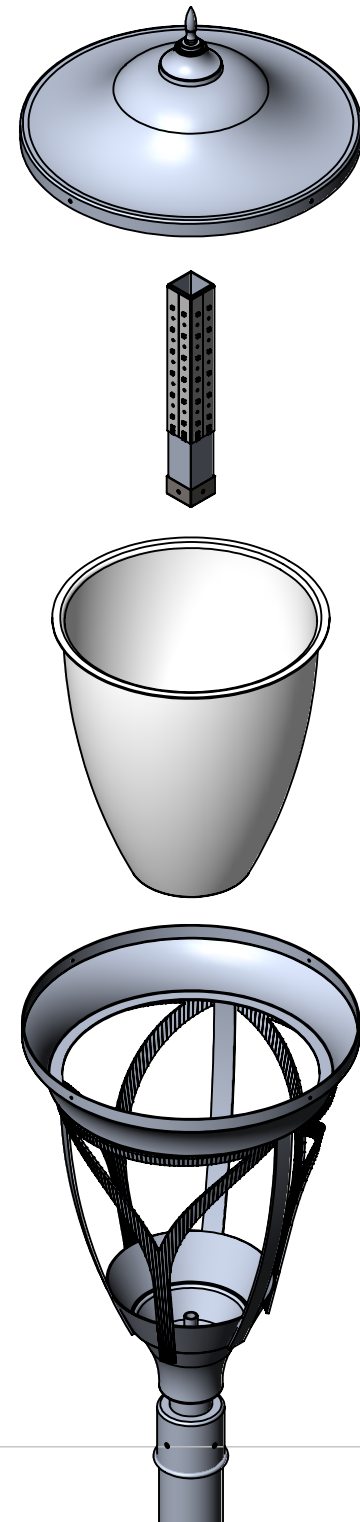
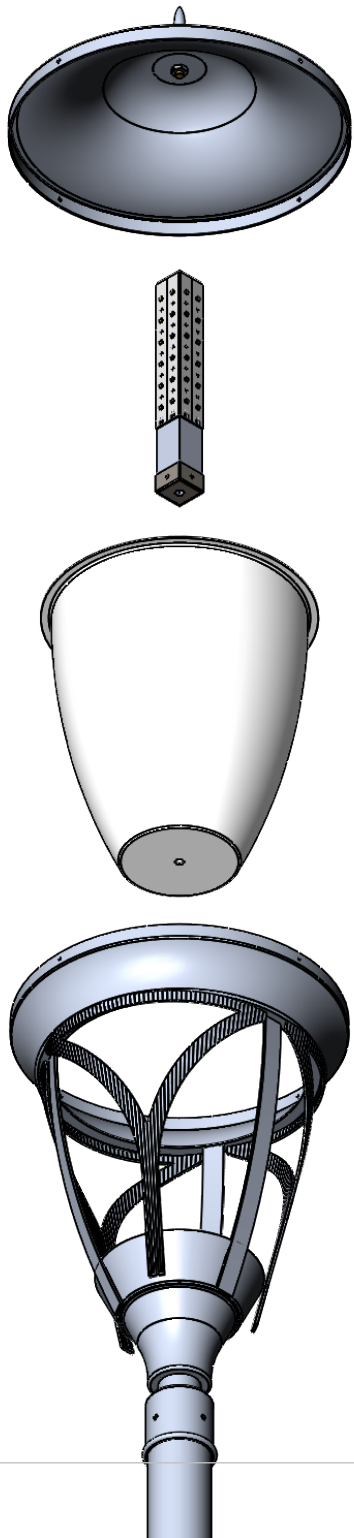
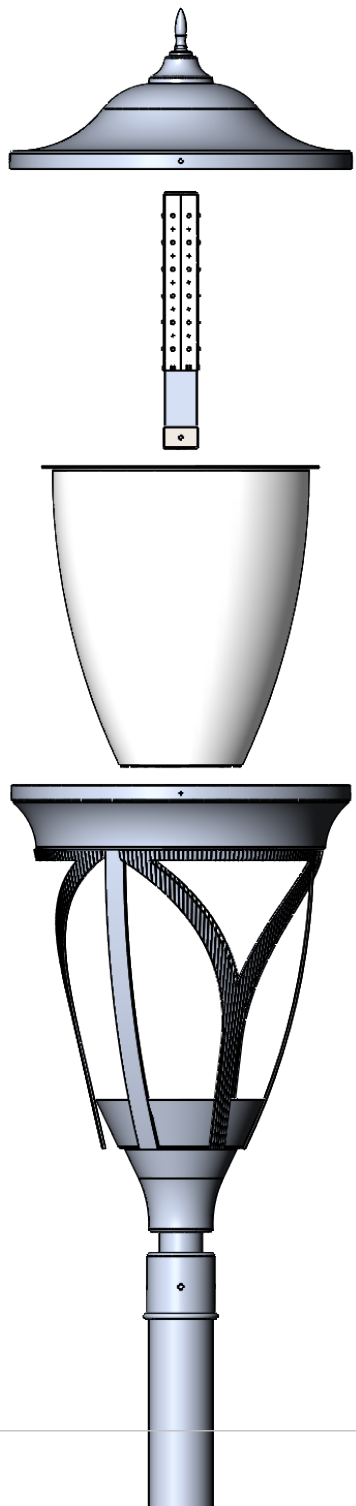

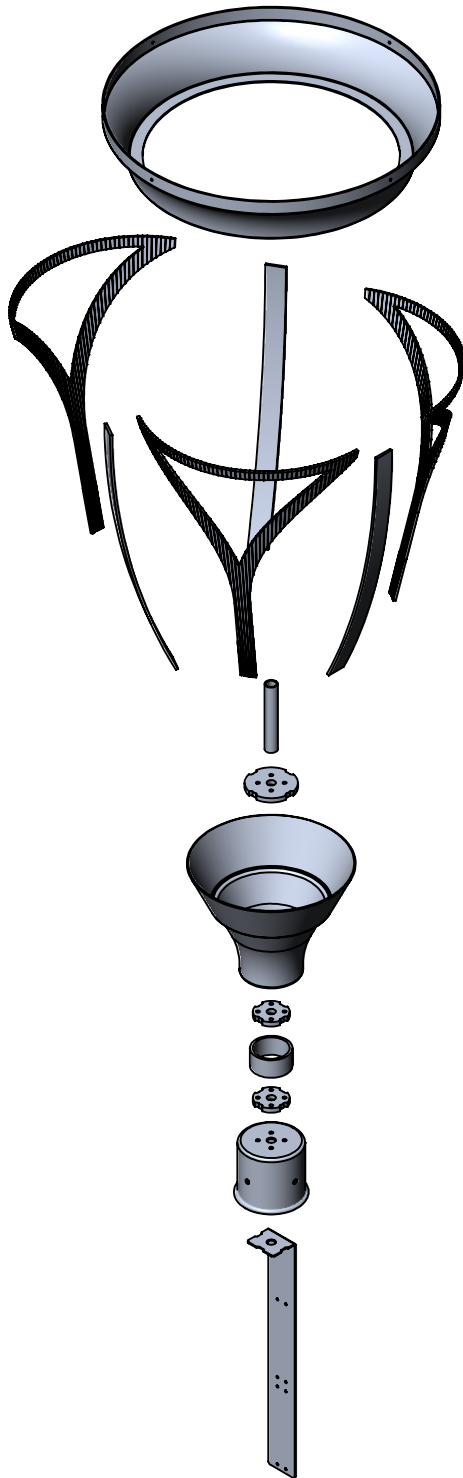

VERTICAL TRAPS TO COVER THE "Y" STRAP CORNERS

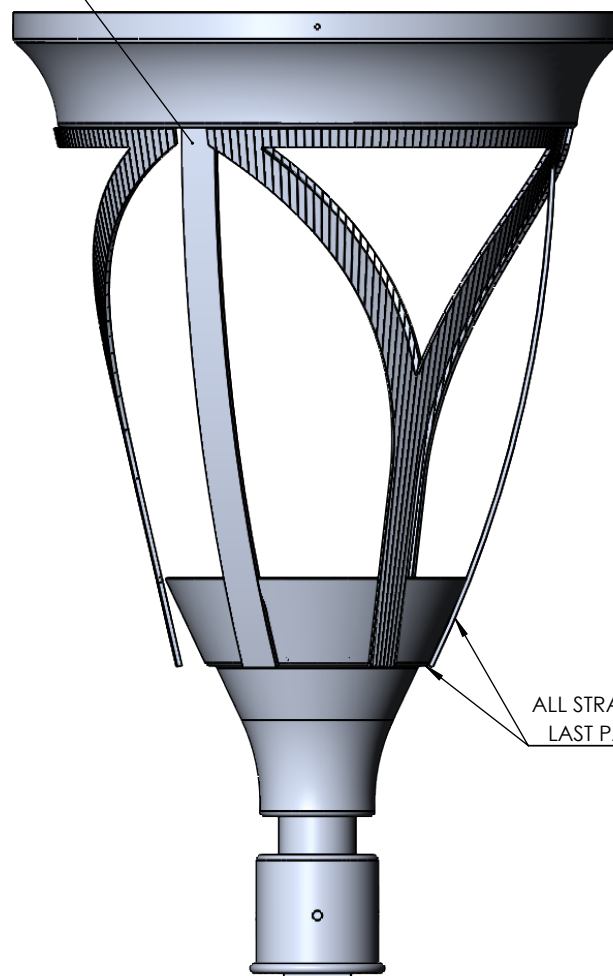

ALL STRAPS SHOULD COVER THE LAST PART OF THE SPUN CUP

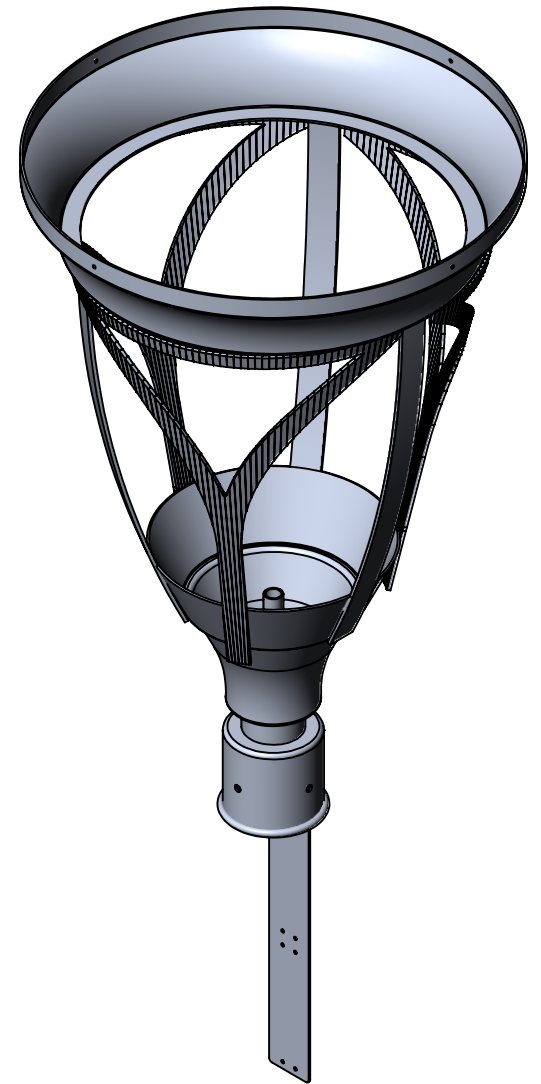

ITEM NO.	PART NUMBER	DESCRIPTION	QTY.
1	YSHP-PST-60W-TVP-A-13AB3-RD-AL-X442-30K- CUSTOM POST FITTER	3" ALUMINUM POST FITTER	1

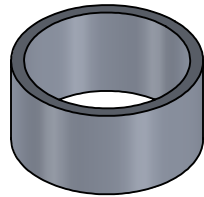
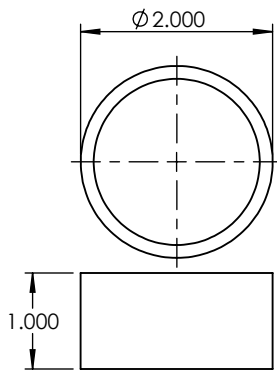
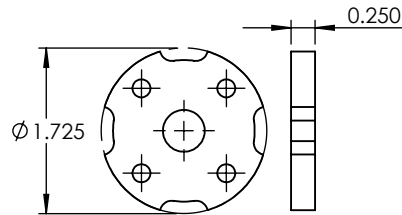
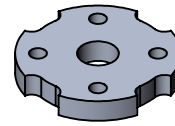
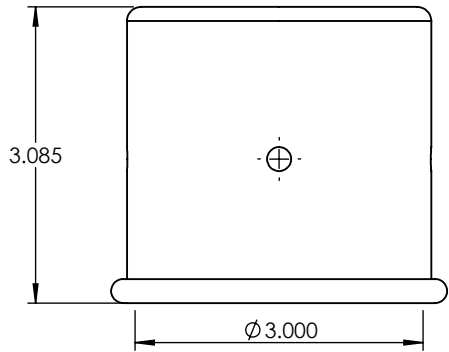
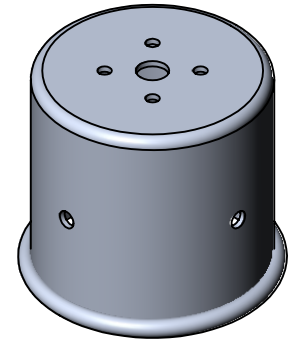
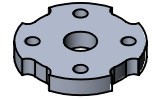
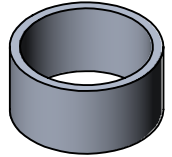
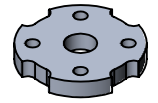
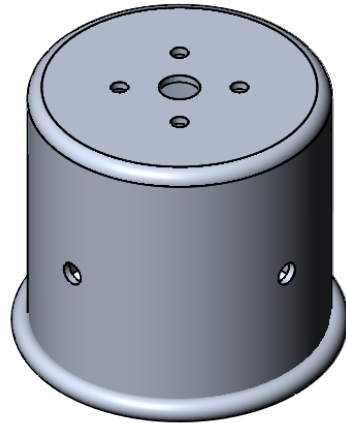
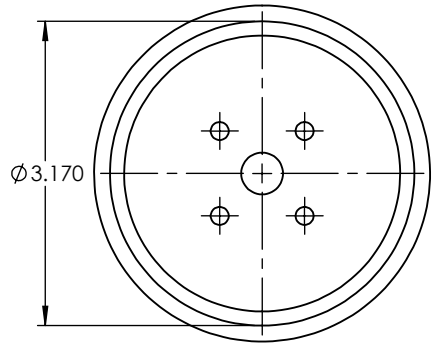

UNLESS OTHERWISE SPECIFIED:
 DIMENSIONS ARE IN INCHES
 TOLERANCES:
 FRACTIONAL ±
 ANGULAR: MACH ± BEND ±
 TWO PLACE DECIMAL ±
 THREE PLACE DECIMAL ±

INTERPRET GEOMETRIC TOLERANCING PER:
 MATERIAL
 FINISH
 DO NOT SCALE DRAWING

NAME	DATE
DRAWN	
CHECKED	
ENG APPR.	
MFG APPR.	
Q.A.	

3" ALUMINUM POST FITTER
 TITLE:
 YSHP-PST-60W-TVP-A-13AB3-RD-AL-X442-30K

PROPRIETARY AND CONFIDENTIAL
 THE INFORMATION CONTAINED IN THIS DRAWING IS THE SOLE PROPERTY OF <INSERT COMPANY NAME HERE>. ANY REPRODUCTION IN PART OR AS A WHOLE WITHOUT THE WRITTEN PERMISSION OF <INSERT COMPANY NAME HERE> IS PROHIBITED.

NEXT ASSY	USED ON
APPLICATION	

COMMENTS:

SIZE	DWG. NO.	REV
A		
SCALE: 1:2	WEIGHT:	SHEET 5 OF 12

ITEM NO.	PART NUMBER	DESCRIPTION	QTY.
1	YSHP-PST-60W-TVP-A-13AB3-RD-AL-X442-30K-SPUN BOTTOM	SPUN ALUMINUM 0.080"	1

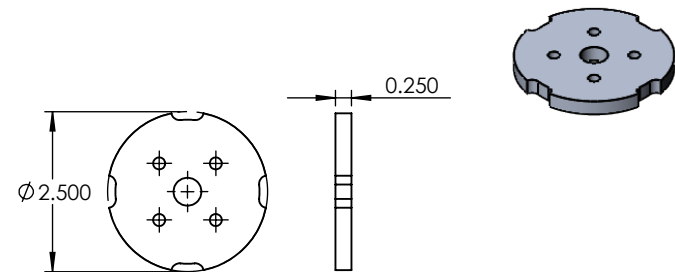
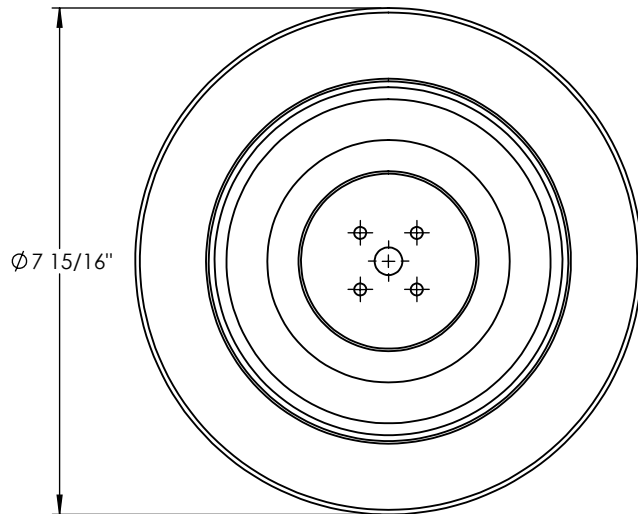
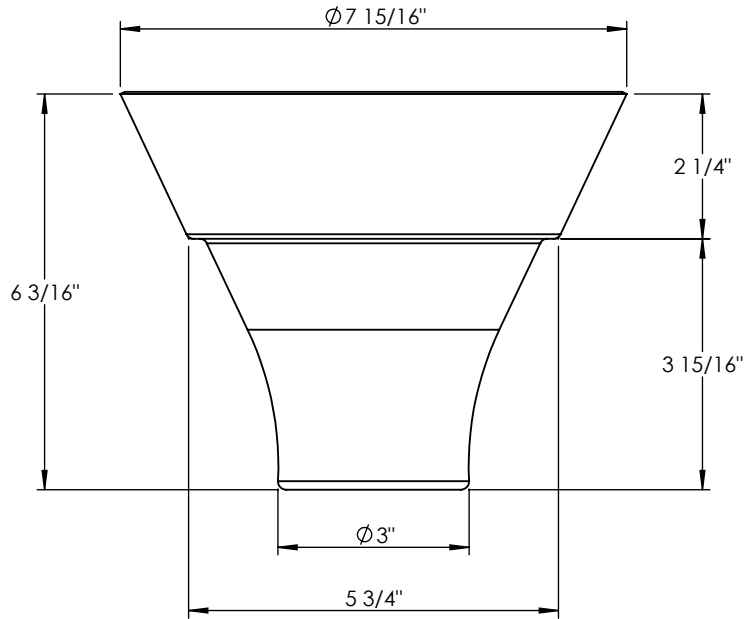

UNLESS OTHERWISE SPECIFIED:		NAME	DATE	SPUN ALUMINUM 0.080"	
DIMENSIONS ARE IN INCHES TOLERANCES: FRACTIONAL ± ANGULAR: MACH ± BEND ± TWO PLACE DECIMAL ± THREE PLACE DECIMAL ±		DRAWN		TITLE:	
INTERPRET GEOMETRIC TOLERANCING PER:		CHECKED		YSHP-PST-60W-TVP-A-13AB3-RD-AL-X442-30K	
MATERIAL		ENG APPR.		SIZE DWG. NO. REV	
FINISH		MFG APPR.		A	
NEXT ASSY		Q.A.		SCALE: 1:3 WEIGHT: SHEET 6 OF 12	
USED ON		COMMENTS:			
APPLICATION					
DO NOT SCALE DRAWING					

PROPRIETARY AND CONFIDENTIAL
THE INFORMATION CONTAINED IN THIS DRAWING IS THE SOLE PROPERTY OF <INSERT COMPANY NAME HERE>. ANY REPRODUCTION IN PART OR AS A WHOLE WITHOUT THE WRITTEN PERMISSION OF <INSERT COMPANY NAME HERE> IS PROHIBITED.

ITEM NO.	PART NUMBER	DESCRIPTION	QTY.
1	YSHP-PST-60W-TVP-A-13AB3-RD-AL-X442-30K-TOP LENS SPACER	SPUN ALUMINUM 0.080"	1

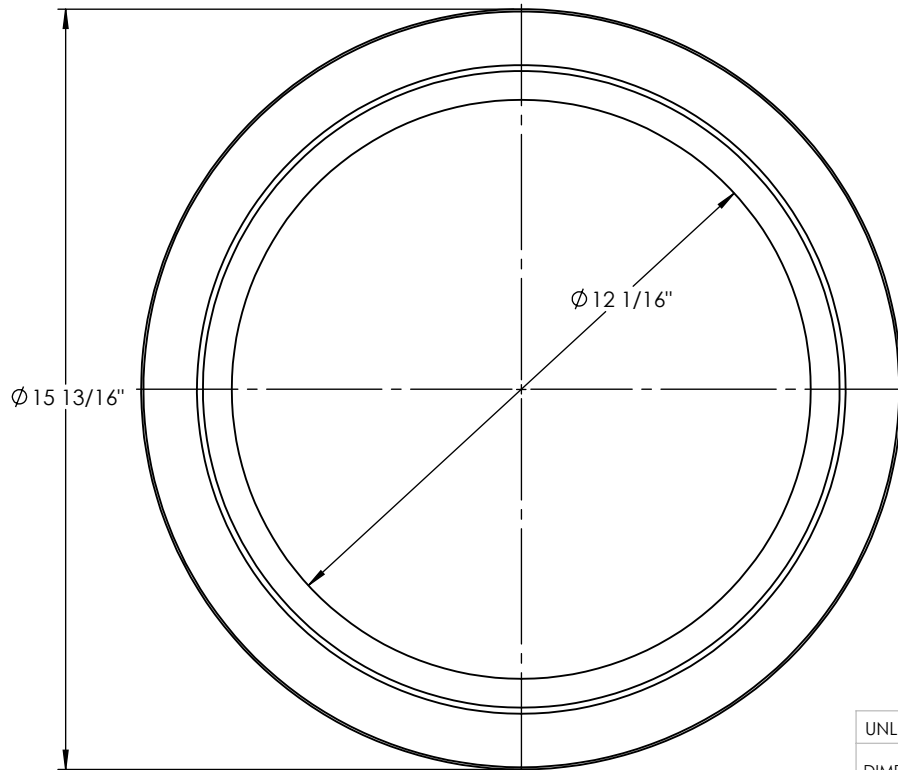
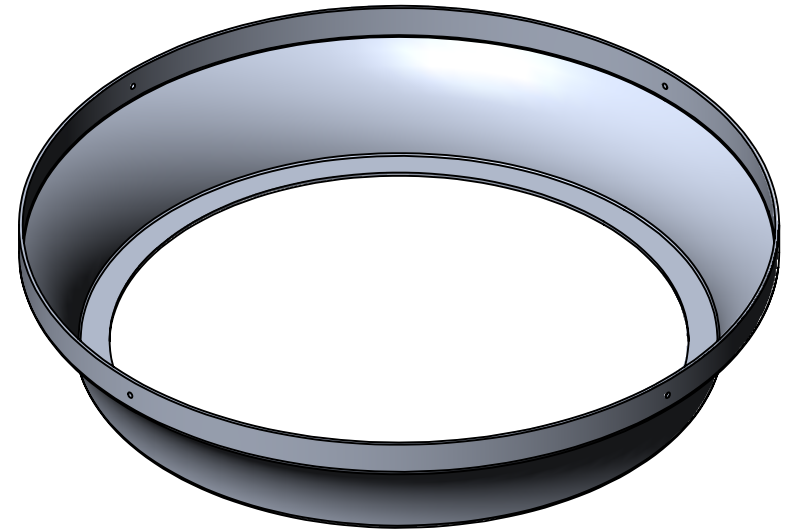
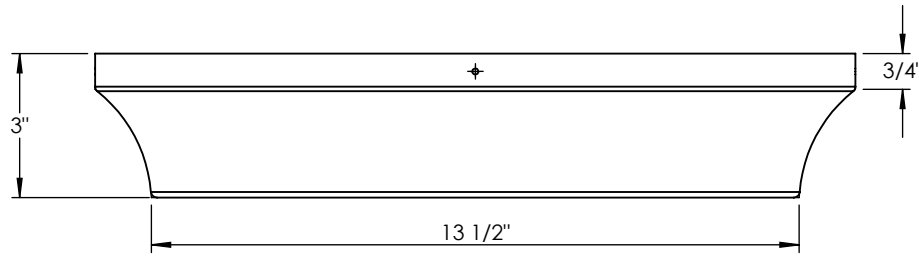

UNLESS OTHERWISE SPECIFIED:		NAME	DATE	SPUN ALUMINUM 0.080"	
DIMENSIONS ARE IN INCHES TOLERANCES: FRACTIONAL ± ANGULAR: MACH ± BEND ± TWO PLACE DECIMAL ± THREE PLACE DECIMAL ±		DRAWN		TITLE:	
		CHECKED		YSHP-PST-60W-TVP-A-13AB3-RD-AL-X442-30K	
		ENG APPR.			
		MFG APPR.			
		Q.A.			
		COMMENTS:			
		INTERPRET GEOMETRIC TOLERANCING PER:		SIZE	DWG. NO.
		MATERIAL		A	
		FINISH			REV
		DO NOT SCALE DRAWING		SCALE: 1:4	WEIGHT:
					SHEET 7 OF 12

PROPRIETARY AND CONFIDENTIAL
THE INFORMATION CONTAINED IN THIS DRAWING IS THE SOLE PROPERTY OF <INSERT COMPANY NAME HERE>. ANY REPRODUCTION IN PART OR AS A WHOLE WITHOUT THE WRITTEN PERMISSION OF <INSERT COMPANY NAME HERE> IS PROHIBITED.

NEXT ASSY	USED ON
APPLICATION	

ITEM NO.	PART NUMBER	DESCRIPTION	QTY.
1	YSHP-PST-60W-TVP-A-13AB3-RD-AL-X442-30K-SPUN SHADE	SPUN ALUMINUM 0.080"	1

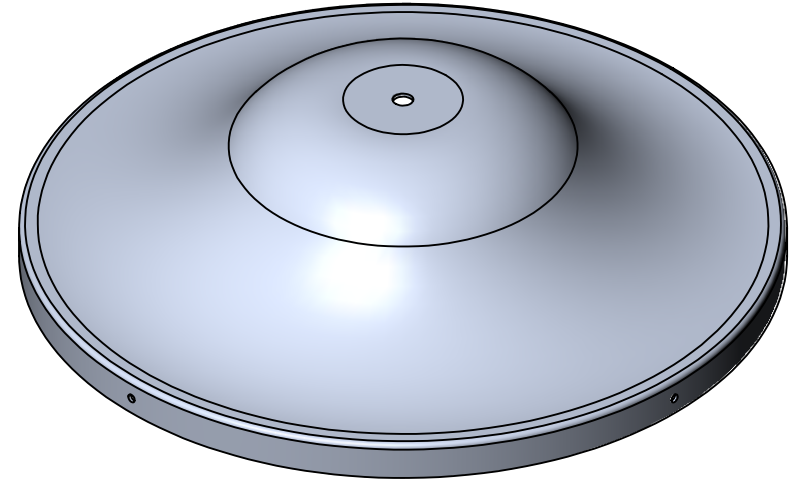
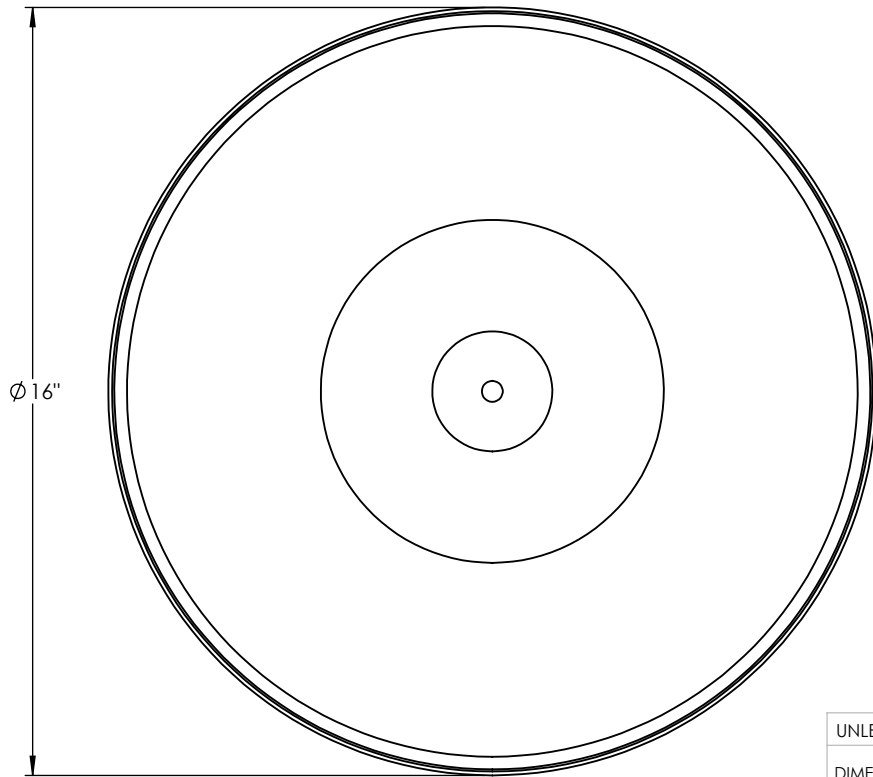
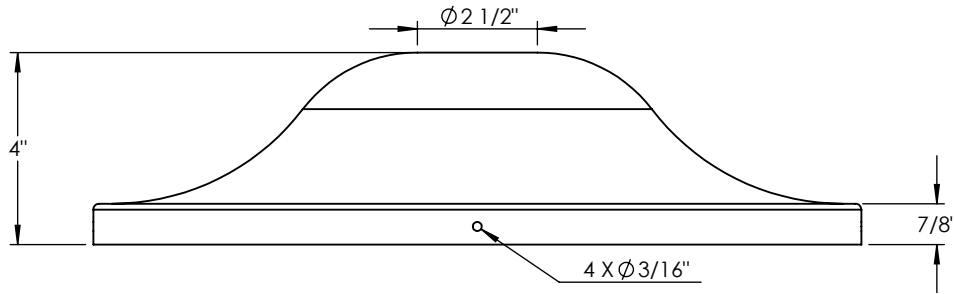

ITEM NO.	PART NUMBER	DESCRIPTION	QTY.
1	YSHP-PST-60W-TVP-A-13AB3-RD-AL-X442-30K-TOP SPUN ACCENTS	SPUN ALUMINUM 0.080"	1

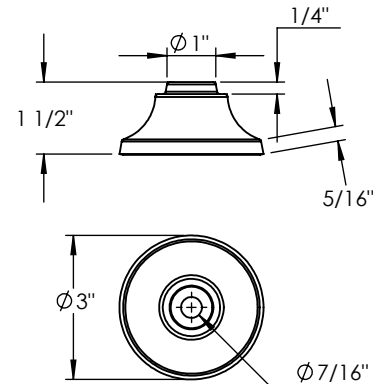

UNLESS OTHERWISE SPECIFIED:		NAME	DATE	SPUN ALUMINUM 0.080"	
DIMENSIONS ARE IN INCHES TOLERANCES: FRACTIONAL ± ANGULAR: MACH ± BEND ± TWO PLACE DECIMAL ± THREE PLACE DECIMAL ±		DRAWN		TITLE:	
INTERPRET GEOMETRIC TOLERANCING PER:		CHECKED		YSHP-PST-60W-TVP-A-13AB3-RD-AL-X442-30K	
MATERIAL		ENG APPR.		Q.A.	
FINISH		MFG APPR.		COMMENTS:	
PROPRIETARY AND CONFIDENTIAL THE INFORMATION CONTAINED IN THIS DRAWING IS THE SOLE PROPERTY OF <INSERT COMPANY NAME HERE>. ANY REPRODUCTION IN PART OR AS A WHOLE WITHOUT THE WRITTEN PERMISSION OF <INSERT COMPANY NAME HERE> IS PROHIBITED.	NEXT ASSY	USED ON	SIZE	DWG. NO.	REV
APPLICATION	DO NOT SCALE DRAWING		A		
	SCALE: 1:4	WEIGHT:	SHEET 8 OF 12		

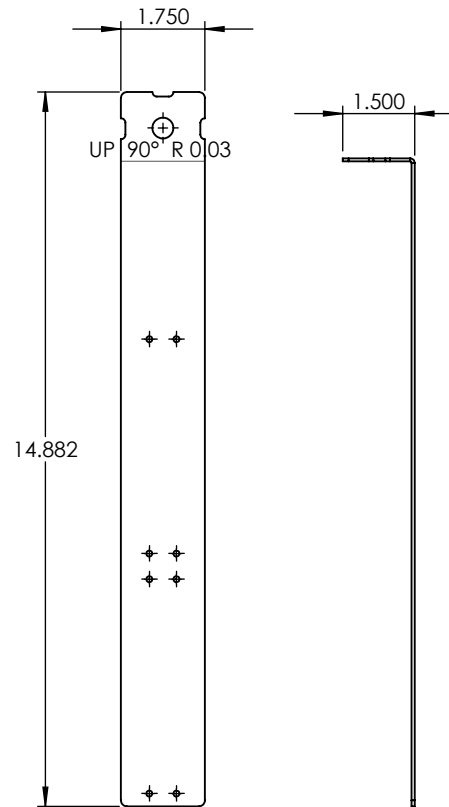
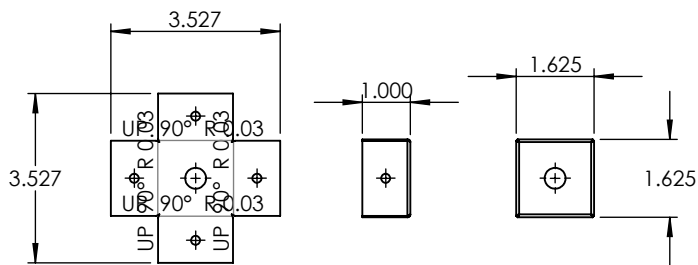
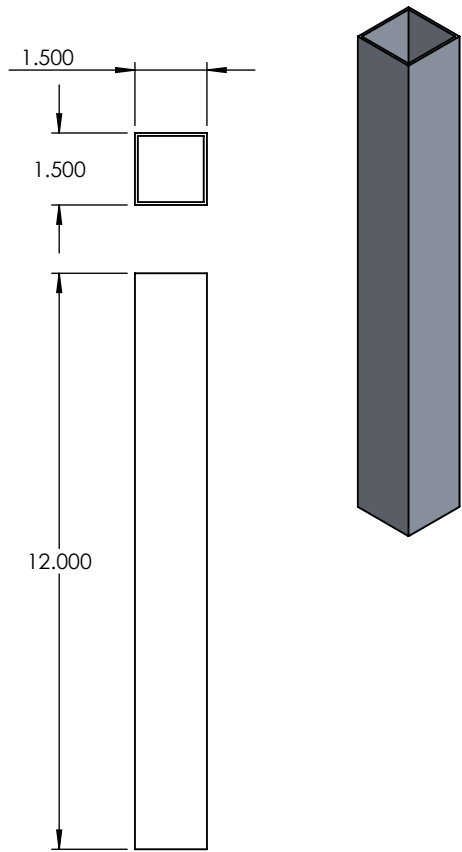

UNLESS OTHERWISE SPECIFIED:		NAME	DATE	22 GAUGE		
DIMENSIONS ARE IN INCHES TOLERANCES: FRACTIONAL ± ANGULAR: MACH ± BEND ± TWO PLACE DECIMAL ± THREE PLACE DECIMAL ±		DRAWN				TITLE:
INTERPRET GEOMETRIC TOLERANCING PER:		ENG APPR.		YSHP-PST-60W-TVP-A-13AB3-RD-AL-X442-30K		
MATERIAL		MFG APPR.				
FINISH		Q.A.		COMMENTS:		
DO NOT SCALE DRAWING				SIZE	DWG. NO.	REV
				A		
				SCALE: 1:4	WEIGHT:	SHEET 9 OF 12

PROPRIETARY AND CONFIDENTIAL
THE INFORMATION CONTAINED IN THIS DRAWING IS THE SOLE PROPERTY OF <INSERT COMPANY NAME HERE>. ANY REPRODUCTION IN PART OR AS A WHOLE WITHOUT THE WRITTEN PERMISSION OF <INSERT COMPANY NAME HERE> IS PROHIBITED.

NEXT ASSY	USED ON
APPLICATION	

5

4

3

2

1

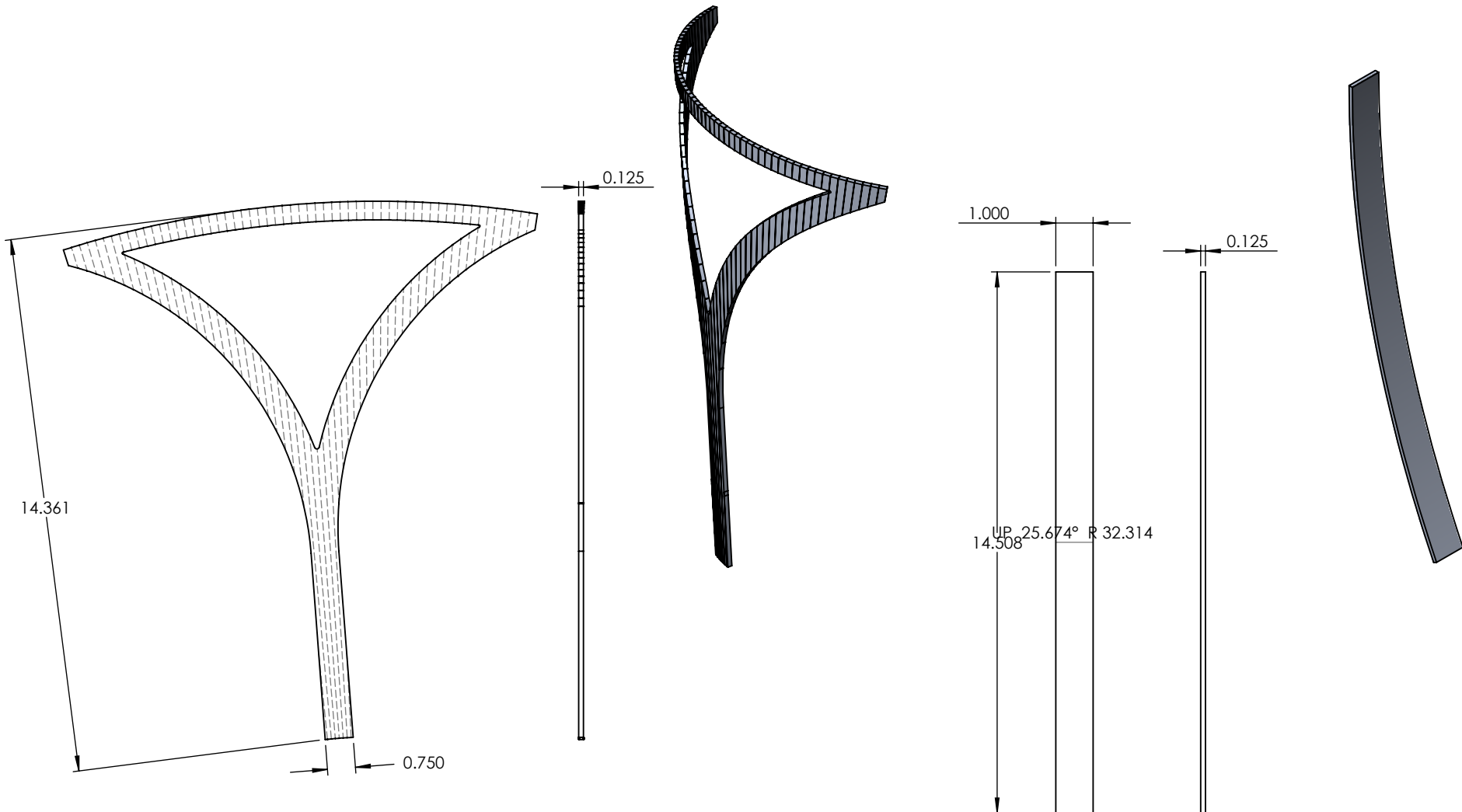

PROPRIETARY AND CONFIDENTIAL
 THE INFORMATION CONTAINED IN THIS DRAWING IS THE SOLE PROPERTY OF <INSERT COMPANY NAME HERE>. ANY REPRODUCTION IN PART OR AS A WHOLE WITHOUT THE WRITTEN PERMISSION OF <INSERT COMPANY NAME HERE> IS PROHIBITED.

		UNLESS OTHERWISE SPECIFIED:		NAME	DATE
		DIMENSIONS ARE IN INCHES	DRAWN		
		TOLERANCES:	CHECKED		
		FRACTIONAL ±	ENG APPR.		
		ANGULAR: MACH ± BEND ±	MFG APPR.		
		TWO PLACE DECIMAL ±	Q.A.		
		THREE PLACE DECIMAL ±	COMMENTS:		
		INTERPRET GEOMETRIC TOLERANCING PER:			
		MATERIAL			
		FINISH			
NEXT ASSY	USED ON				
APPLICATION		DO NOT SCALE DRAWING			

ALUMINUM 0.125" PLATE		
TITLE:		
YSHP-PST-60W-TVP-A-13AB3-RD-AL-X442-30K		
SIZE	DWG. NO.	REV
A		
SCALE: 1:4	WEIGHT:	SHEET 10 OF 12

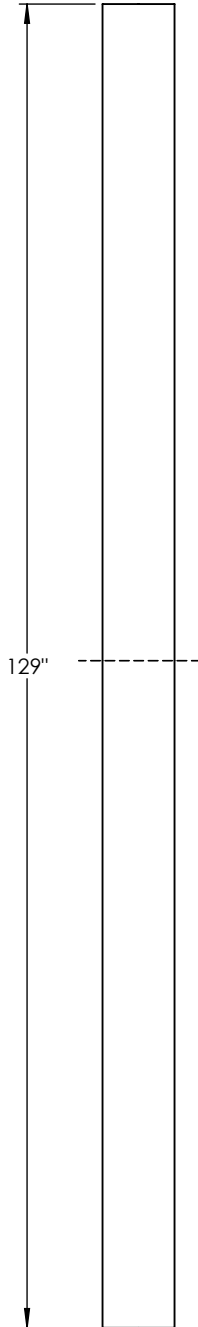
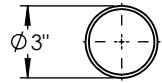

5



4

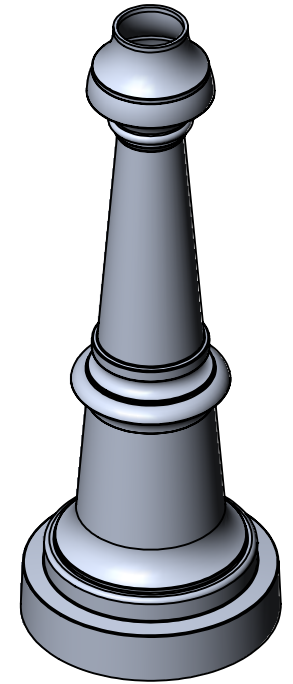
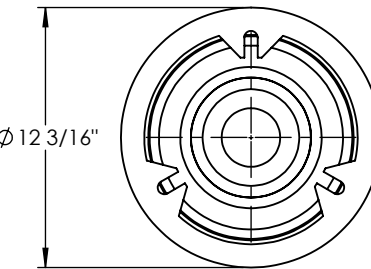
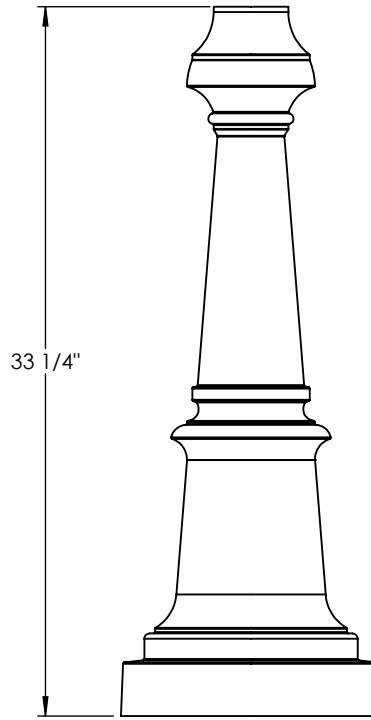

UNLESS OTHERWISE SPECIFIED:		NAME	DATE	3" ALUMINUM TUBE	
DIMENSIONS ARE IN INCHES		DRAWN			
TOLERANCES:		CHECKED		YSHP-PST-60W-TVP-A-13AB3-RD-AL-X442-30K	
FRACTIONAL ±		ENG APPR.			
ANGULAR: MACH ± BEND ±		MFG APPR.		SCALE: 1:8 WEIGHT: SHEET 11 OF 12	
TWO PLACE DECIMAL ±		Q.A.			
THREE PLACE DECIMAL ±		COMMENTS:		DO NOT SCALE DRAWING	
INTERPRET GEOMETRIC TOLERANCING PER:					
MATERIAL					
FINISH					

3

2

1

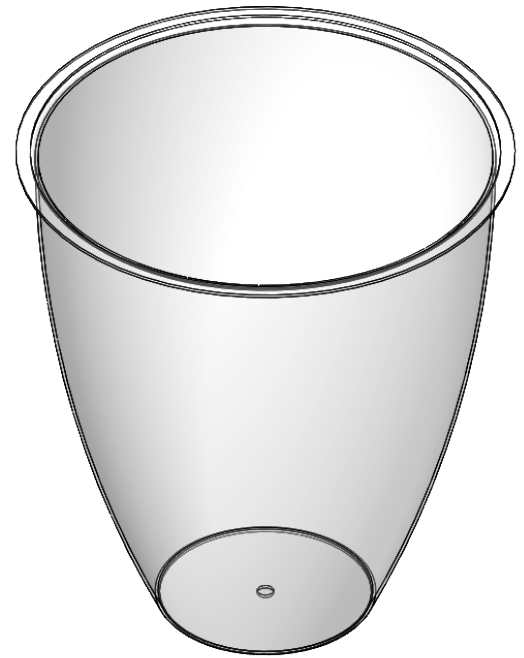
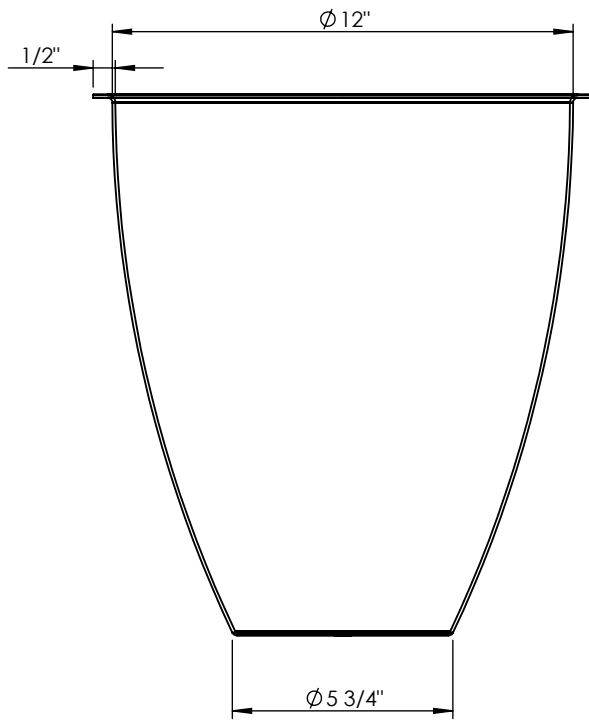

PROPRIETARY AND CONFIDENTIAL
 THE INFORMATION CONTAINED IN THIS DRAWING IS THE SOLE PROPERTY OF <INSERT COMPANY NAME HERE>. ANY REPRODUCTION IN PART OR AS A WHOLE WITHOUT THE WRITTEN PERMISSION OF <INSERT COMPANY NAME HERE> IS PROHIBITED.

		UNLESS OTHERWISE SPECIFIED:		NAME	DATE	ACRYLIC		
		DIMENSIONS ARE IN INCHES TOLERANCES: FRACTIONAL \pm ANGULAR: MACH \pm BEND \pm TWO PLACE DECIMAL \pm THREE PLACE DECIMAL \pm	DRAWN					TITLE:
		INTERPRET GEOMETRIC TOLERANCING PER:	CHECKED			YSHP-PST-60W-TVP-A-13AB3-RD-AL-X442-30K		
		MATERIAL	ENG APPR.					
		FINISH	MFG APPR.			SIZE	DWG. NO.	REV
NEXT ASSY	USED ON		Q.A.			A		
APPLICATION		DO NOT SCALE DRAWING	COMMENTS:			SCALE: 1:5	WEIGHT:	SHEET 12 OF 12