

ALL BEND RADIUS .030"

UNLESS OTHERWISE SPECIFIED:

DIMENSIONS ARE IN INCHES
 TOLERANCES:
 FRACTIONAL ± .003
 ANGULAR: MACH ± .01 BEND ±
 TWO PLACE DECIMAL ±
 THREE PLACE DECIMAL ± .001

INTERPRET GEOMETRIC
 TOLERANCING PER:

MATERIAL

FINISH

DO NOT SCALE DRAWING

NAME	DATE

DRAWN
 CHECKED
 ENG APPR.
 MFG APPR.

Q.A.
 COMMENTS:

TITLE:

GL-P-SGL-MODUP-54W-TW-CG-41K-15X18

SIZE	DWG. NO.	REV
A	TICKET 25728	

SCALE: 1:13 WEIGHT: SHEET 1 OF 13

5

4

3

2

1

ITEM NO.	PART NUMBER	DESCRIPTION	QTY.	CUT
1	GL-P-SGL-MODUP-54W-7-CG-41K-15X18-SPUN CANOPY	SPUN ALUMINUM 0.125"	1	
2	GL-P-SGL-MODUP-54W-7-CG-41K-15X18-SPUN FIREPLATE	SPUN ALUMINUM 0.125"	1	
3	GL-P-SGL-MODUP-54W-7-CG-41K-15X18-0.250" NUT	ALUMINUM 0.250" PLATE	1	
4	GL-P-SGL-MODUP-54W-7-CG-41K-15X18-CANOPY BRACKET	ALUMINUM 0.250" PLATE	1	
5	GL-P-SGL-MODUP-54W-7-CG-41K-15X18-NECK BRACKET CLEAN	ALUMINUM 0.250" PLATE	1	
6	GL-P-SGL-MODUP-54W-7-CG-41K-15X18-NECK BRACKET HOLES	ALUMINUM 0.250" PLATE	1	
7	GL-P-SGL-MODUP-54W-7-CG-41K-15X18-FIREPLATE	ALUMINUM 0.125" PLATE	1	
8	GL-P-SGL-MODUP-54W-7-CG-41K-15X18-FRONT PANEL	ALUMINUM 0.125" PLATE	1	
9	GL-P-SGL-MODUP-54W-7-CG-41K-15X18-TOP PANEL	ALUMINUM 0.125" PLATE	1	
10	GL-P-SGL-MODUP-54W-7-CG-41K-15X18-SIDE PANEL	ALUMINUM 0.125" PLATE	2	
11	GL-P-SGL-MODUP-54W-7-CG-41K-15X18-LED PANEL BRACKET	ALUMINUM 0.0635"	1	
12	GL-P-SGL-MODUP-54W-7-CG-41K-15X18-LED BRACKET	ALUMINUM 0.0635"	1	
13	GL-P-SGL-MODUP-54W-7-CG-41K-15X18-LED PLATE	ALUMINUM 0.0635"	1	
14	GL-P-SGL-MODUP-54W-7-CG-41K-15X18-DRIVER BRACKET	ALUMINUM 0.0635"	1	
15	GL-P-SGL-MODUP-54W-7-CG-41K-15X18-POST NECK	3" SQUARE ALUMINUM TUBE	1	
16	GL-P-SGL-MODUP-54W-7-CG-41K-15X18-0.875" NECK TUBE	7/8" ROUND ALUMINUM TUBE	1	
17	GL-P-SGL-MODUP-54W-7-CG-41K-15X18-ACRYLIC	ACRYLIC	1	
18	ESPEN VEL29070MVH-1	DRIVER	3	
19	Altailed_PN110B_RevC	LED	6	

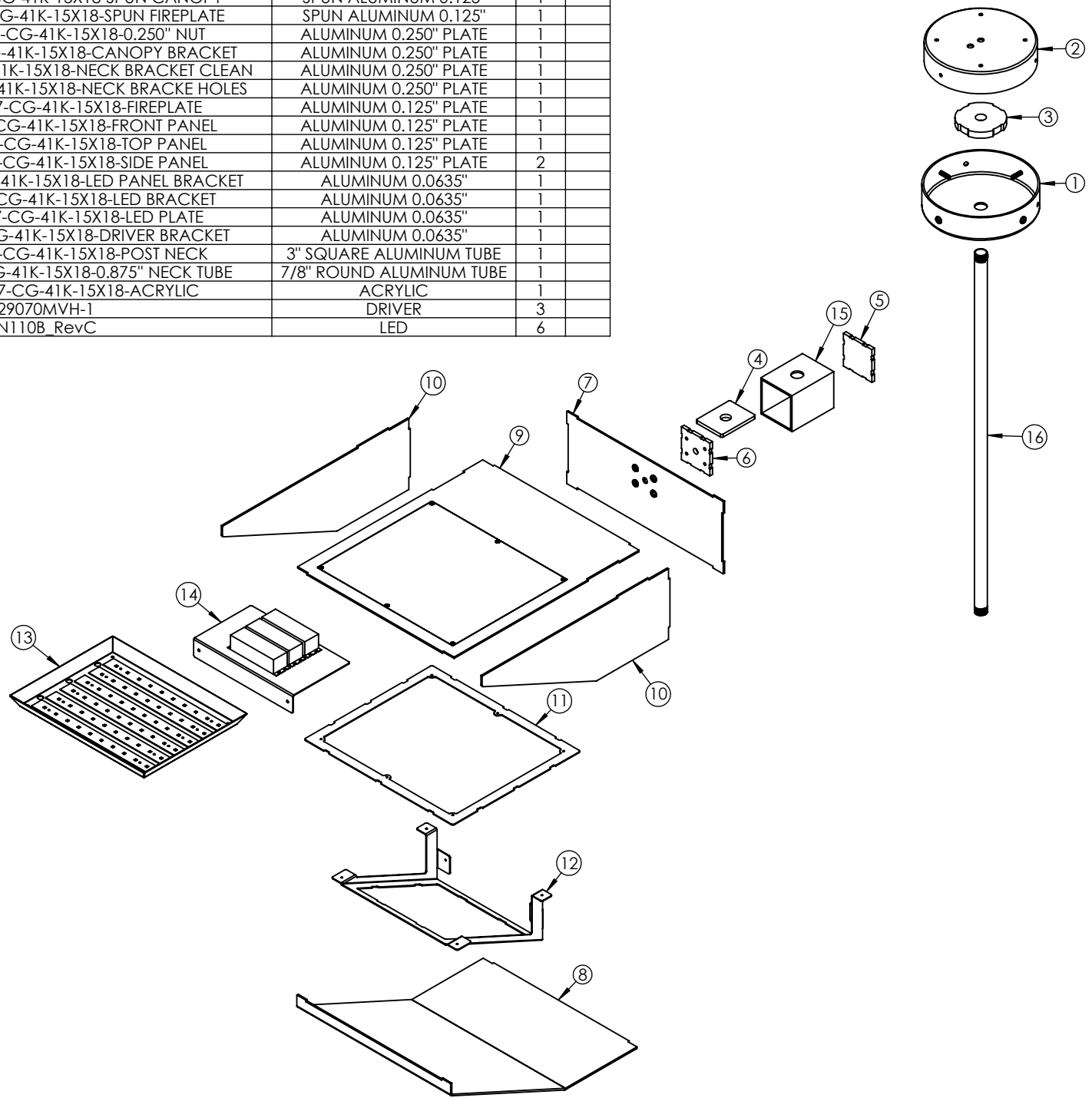

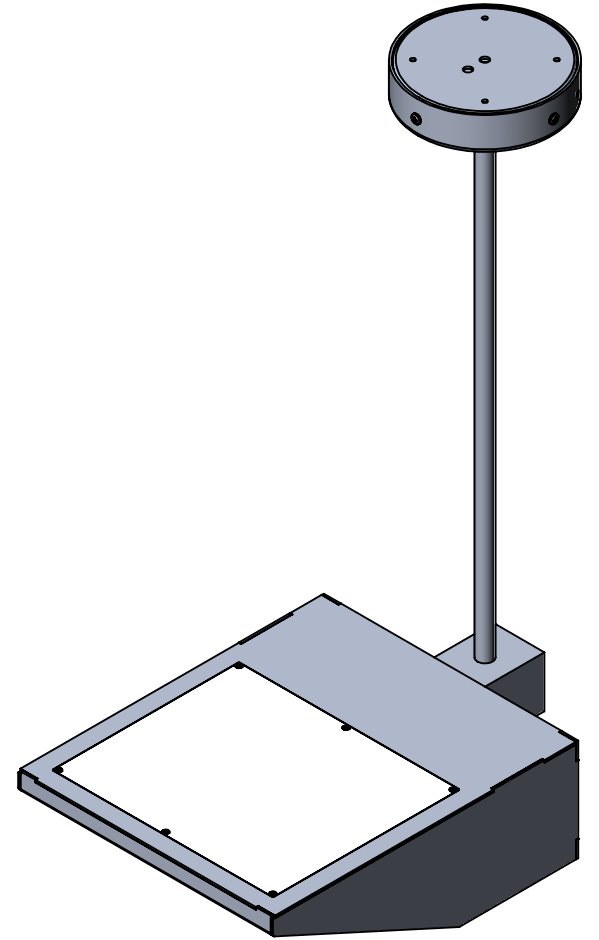
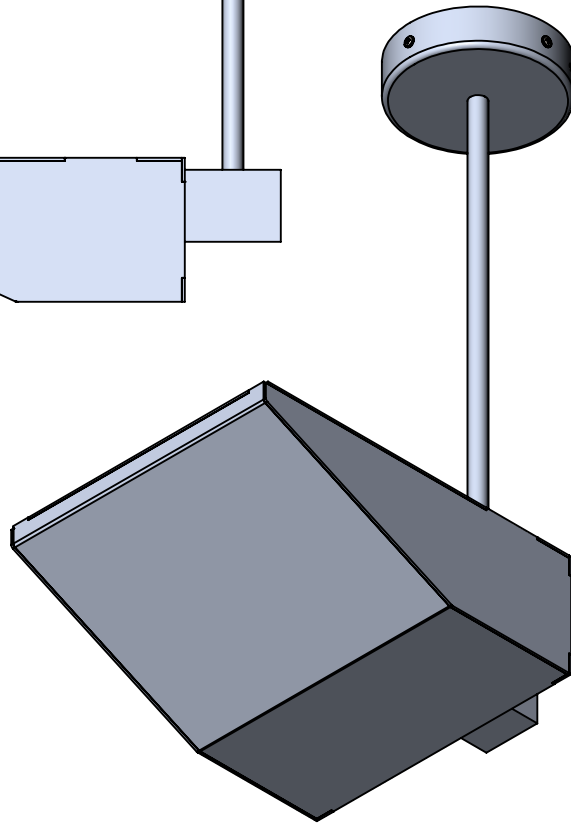
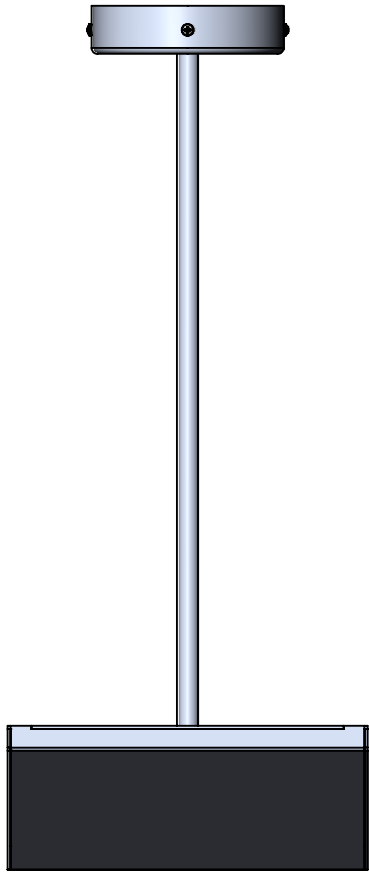

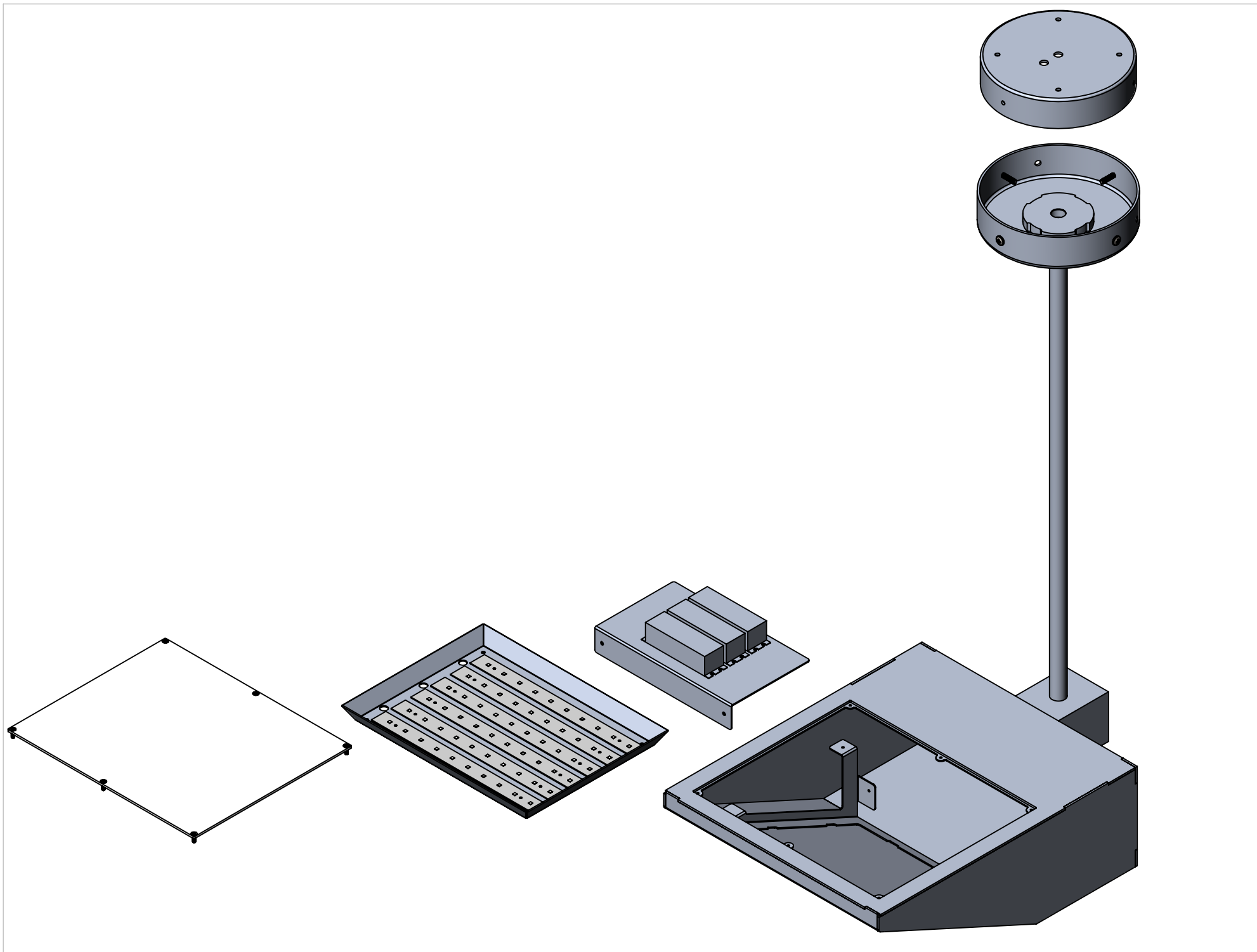

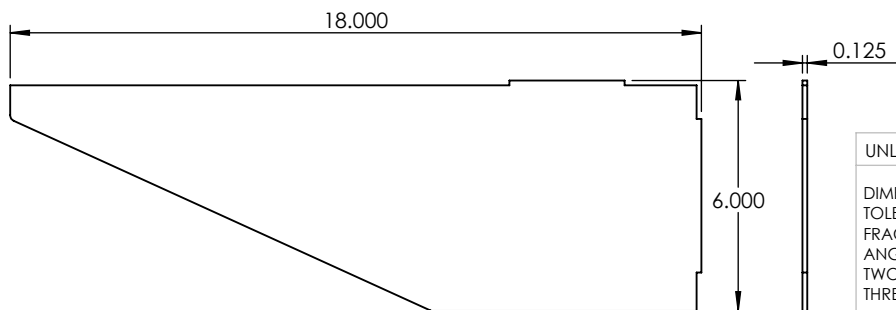
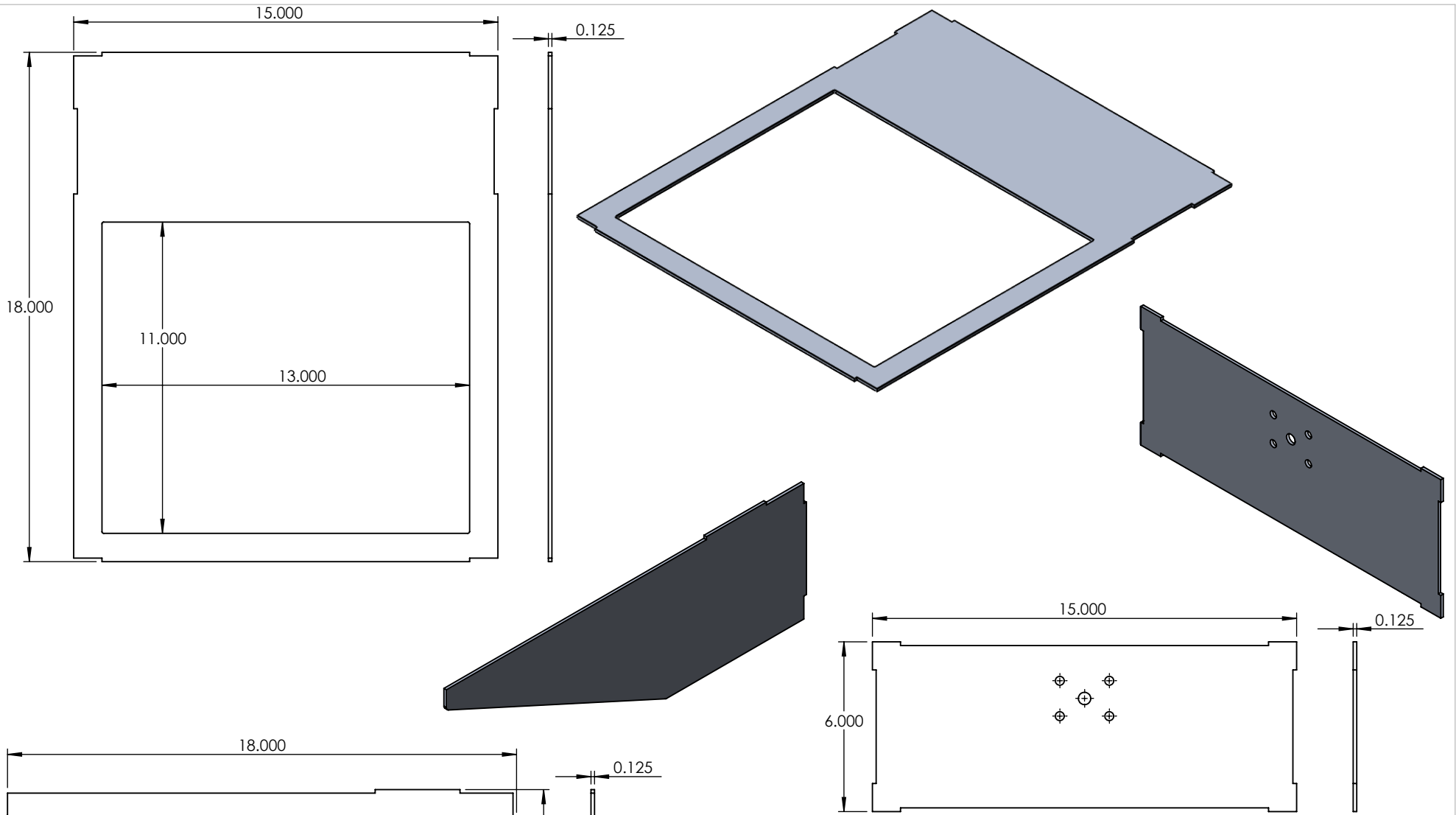

UNLESS OTHERWISE SPECIFIED:

DIMENSIONS ARE IN INCHES
 TOLERANCES:
 FRACTIONAL ±
 ANGULAR: MACH ± BEND ±
 TWO PLACE DECIMAL ±
 THREE PLACE DECIMAL ±

INTERPRET GEOMETRIC TOLERANCING PER:

MATERIAL
 FINISH

DO NOT SCALE DRAWING

	NAME	DATE
DRAWN		
CHECKED		
ENG APPR.		
MFG APPR.		
Q.A.		
COMMENTS:		

ALUMINUM 0.064"

TITLE:

GL-P-SGL-MODUP-54W-TW-CG-41K-15X18

PROPRIETARY AND CONFIDENTIAL
 THE INFORMATION CONTAINED IN THIS DRAWING IS THE SOLE PROPERTY OF <INSERT COMPANY NAME HERE>. ANY REPRODUCTION IN PART OR AS A WHOLE WITHOUT THE WRITTEN PERMISSION OF <INSERT COMPANY NAME HERE> IS PROHIBITED.

NEXT ASSY	USED ON
APPLICATION	

SIZE	DWG. NO.	REV
A		
SCALE: 1:5	WEIGHT:	SHEET 5 OF 13

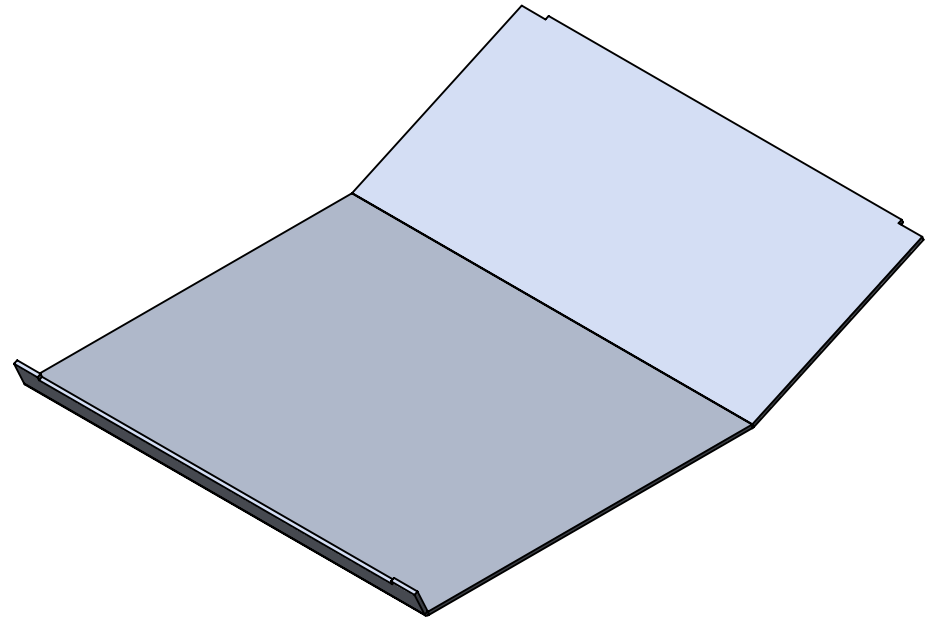
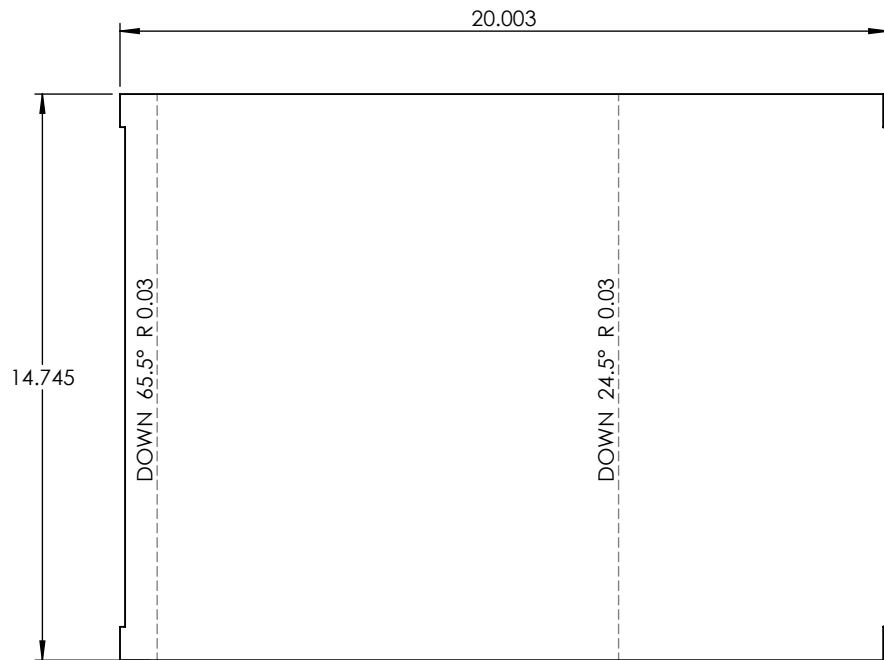
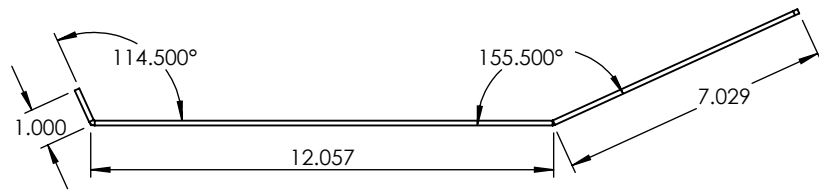

PROPRIETARY AND CONFIDENTIAL
 THE INFORMATION CONTAINED IN THIS DRAWING IS THE SOLE PROPERTY OF <INSERT COMPANY NAME HERE>. ANY REPRODUCTION IN PART OR AS A WHOLE WITHOUT THE WRITTEN PERMISSION OF <INSERT COMPANY NAME HERE> IS PROHIBITED.

		UNLESS OTHERWISE SPECIFIED:		NAME	DATE
		DIMENSIONS ARE IN INCHES	DRAWN		
		TOLERANCES:	CHECKED		
		FRACTIONAL ±	ENG APPR.		
		ANGULAR: MACH ± BEND ±	MFG APPR.		
		TWO PLACE DECIMAL ±	Q.A.		
		THREE PLACE DECIMAL ±	COMMENTS:		
		INTERPRET GEOMETRIC TOLERANCING PER:			
		MATERIAL			
		FINISH			
NEXT ASSY	USED ON				
APPLICATION		DO NOT SCALE DRAWING			

ALUMINUM 0.125" PLATE

TITLE:

GL-P-SGL-MODUP-54W-TW-CG-41K-15X18

SIZE	DWG. NO.	REV
A		

SCALE: 1:5	WEIGHT:	SHEET 6 OF 13
------------	---------	---------------

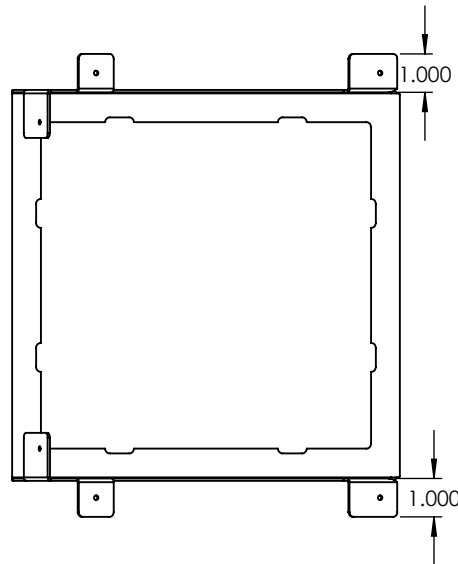
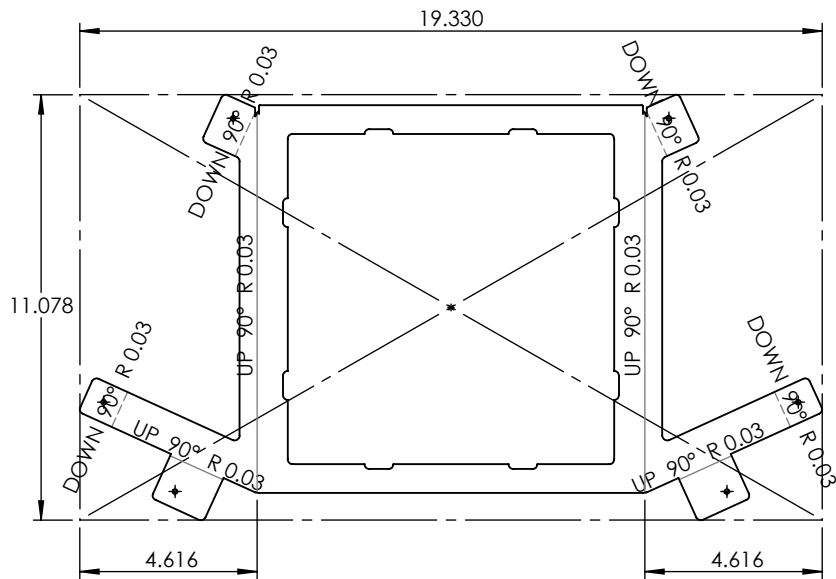
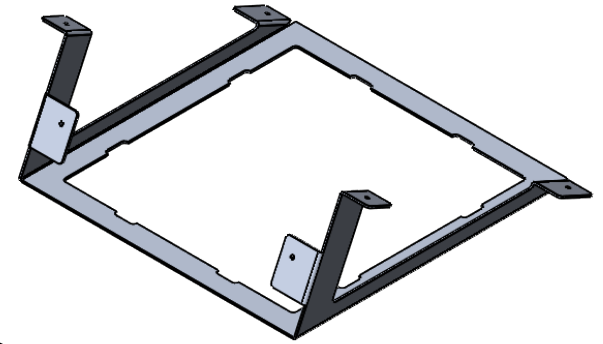

PROPRIETARY AND CONFIDENTIAL
 THE INFORMATION CONTAINED IN THIS DRAWING IS THE SOLE PROPERTY OF <INSERT COMPANY NAME HERE>. ANY REPRODUCTION IN PART OR AS A WHOLE WITHOUT THE WRITTEN PERMISSION OF <INSERT COMPANY NAME HERE> IS PROHIBITED.

		UNLESS OTHERWISE SPECIFIED:	NAME	DATE
		DIMENSIONS ARE IN INCHES	DRAWN	
		TOLERANCES:	CHECKED	
		FRACTIONAL ±	ENG APPR.	
		ANGULAR: MACH ± BEND ±	MFG APPR.	
		TWO PLACE DECIMAL ±	Q.A.	
		THREE PLACE DECIMAL ±	COMMENTS:	
		INTERPRET GEOMETRIC TOLERANCING PER:		
		MATERIAL		
NEXT ASSY	USED ON	FINISH		
APPLICATION		DO NOT SCALE DRAWING		

ALUMINUM 0.0635"

TITLE:
 GL-P-SGL-MODUP-54W-TW-CG-41K-15X18

SIZE DWG. NO. REV
A

SCALE: 1:5 WEIGHT: SHEET 7 OF 13

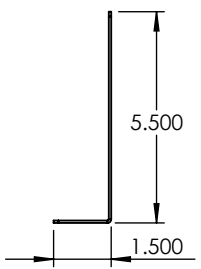
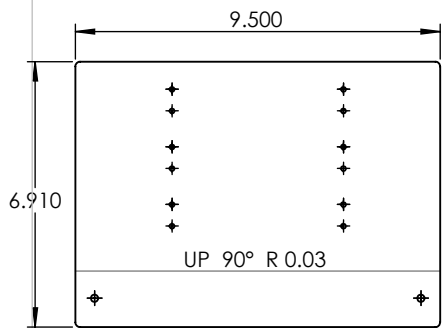
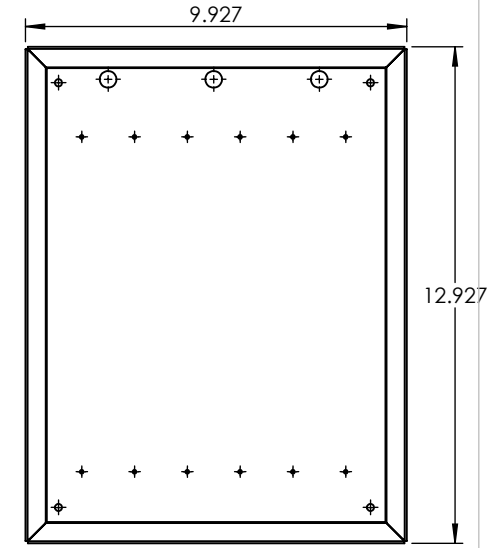
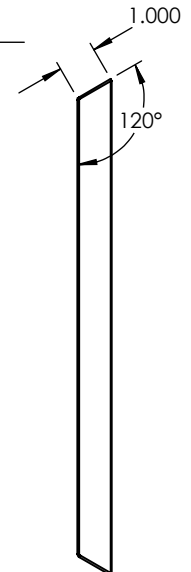
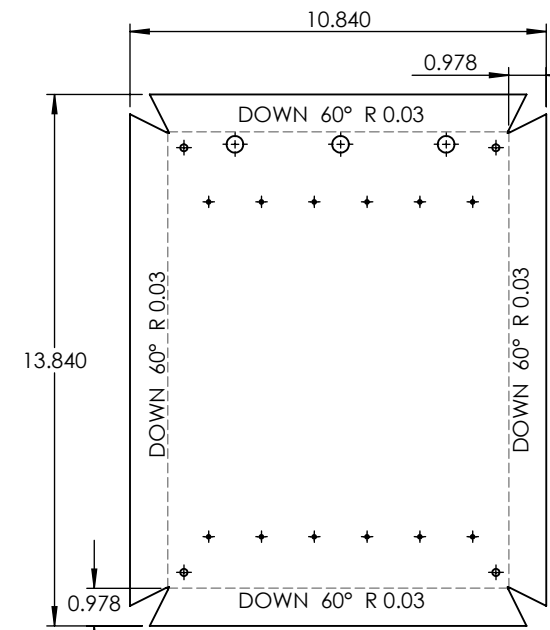
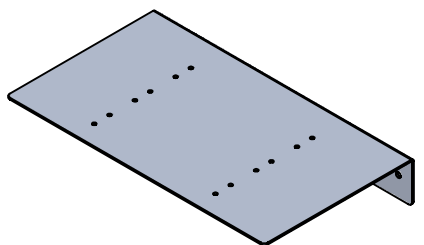
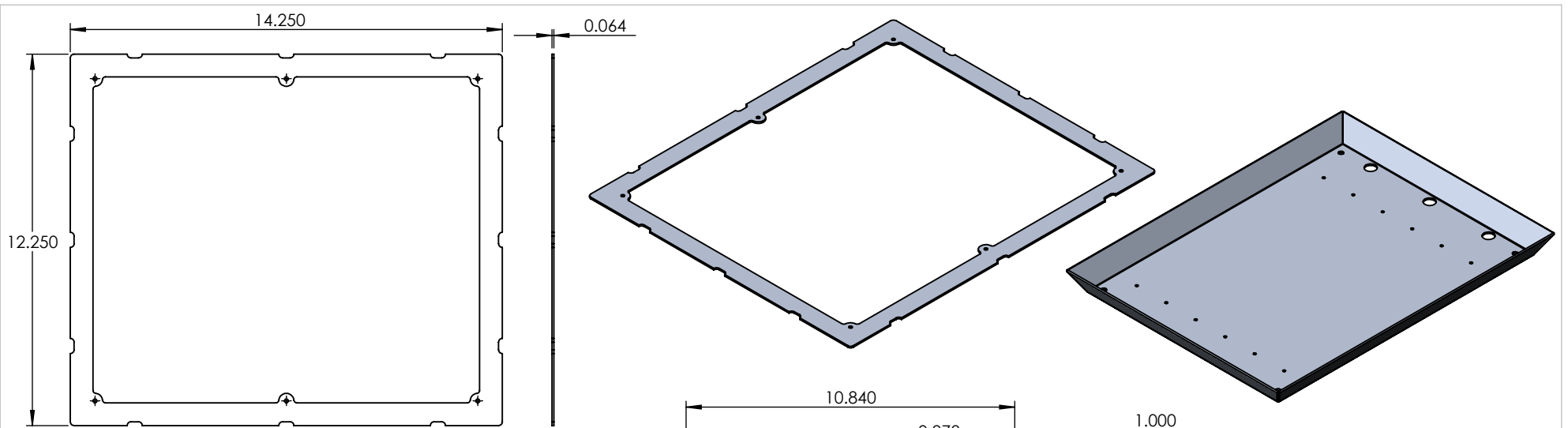

UNLESS OTHERWISE SPECIFIED:

DIMENSIONS ARE IN INCHES
 TOLERANCES:
 FRACTIONAL ±
 ANGULAR: MACH ± BEND ±
 TWO PLACE DECIMAL ±
 THREE PLACE DECIMAL ±

INTERPRET GEOMETRIC TOLERANCING PER:

MATERIAL

FINISH

DO NOT SCALE DRAWING

	NAME	DATE
DRAWN		
CHECKED		
ENG APPR.		
MFG APPR.		
Q.A.		

COMMENTS:

ALUMINUM 0.0635"

TITLE:
 GL-P-SGL-MODUP-54W-TW-CG-41K-15X18

PROPRIETARY AND CONFIDENTIAL
 THE INFORMATION CONTAINED IN THIS DRAWING IS THE SOLE PROPERTY OF <INSERT COMPANY NAME HERE>. ANY REPRODUCTION IN PART OR AS A WHOLE WITHOUT THE WRITTEN PERMISSION OF <INSERT COMPANY NAME HERE> IS PROHIBITED.

NEXT ASSY	USED ON
APPLICATION	

SIZE	DWG. NO.	REV
A		
SCALE: 1:5	WEIGHT:	SHEET 8 OF 13

5

4

3

2

1

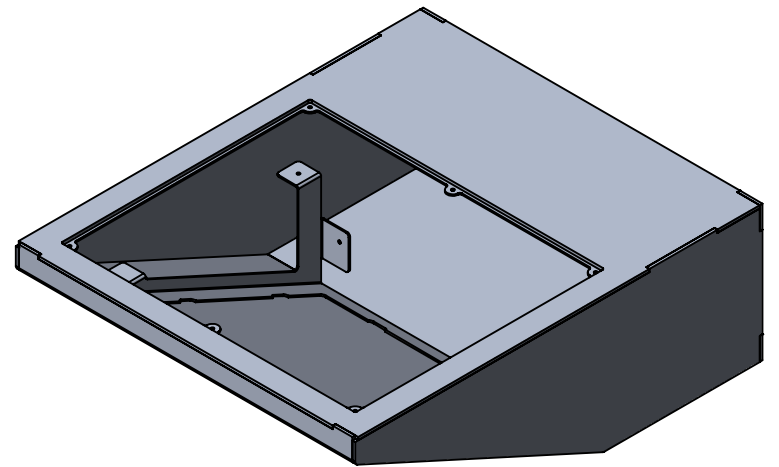
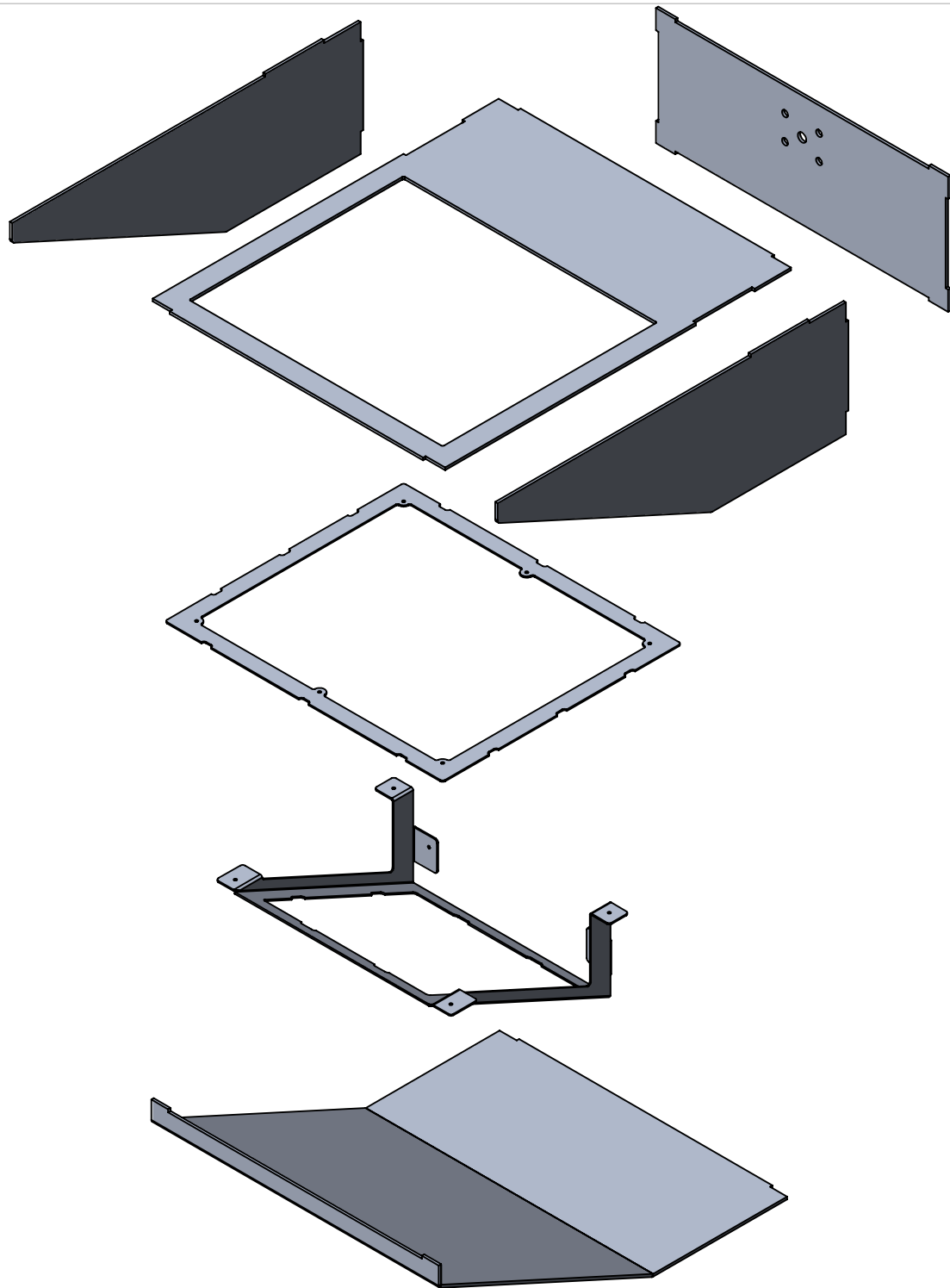

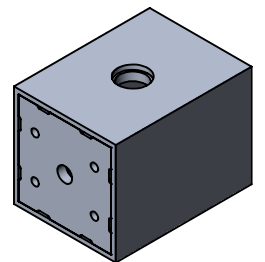
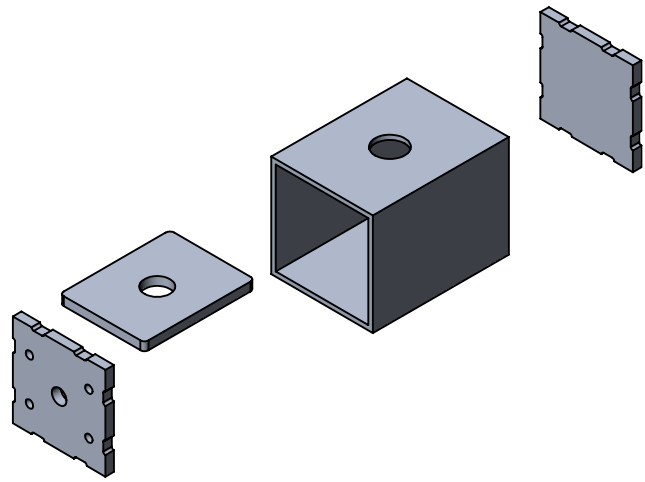
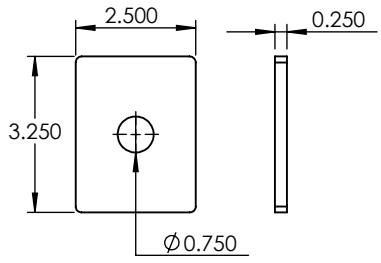
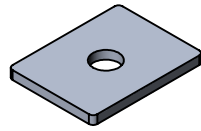
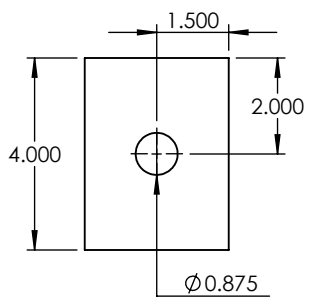
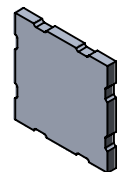
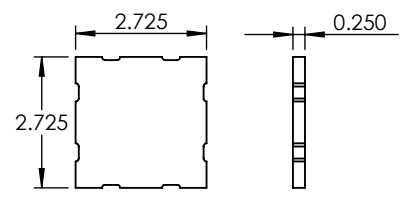
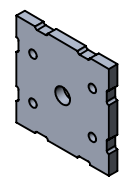
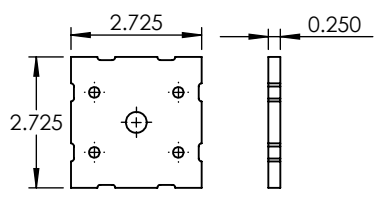
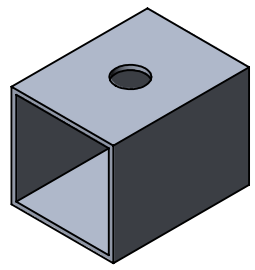
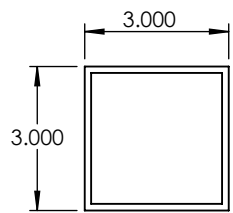

PROPRIETARY AND CONFIDENTIAL
 THE INFORMATION CONTAINED IN THIS DRAWING IS THE SOLE PROPERTY OF <INSERT COMPANY NAME HERE>. ANY REPRODUCTION IN PART OR AS A WHOLE WITHOUT THE WRITTEN PERMISSION OF <INSERT COMPANY NAME HERE> IS PROHIBITED.

		UNLESS OTHERWISE SPECIFIED:		NAME	DATE
		DIMENSIONS ARE IN INCHES	DRAWN		
		TOLERANCES:	CHECKED		
		FRACTIONAL ±	ENG APPR.		
		ANGULAR: MACH ± BEND ±	MFG APPR.		
		TWO PLACE DECIMAL ±	Q.A.		
		THREE PLACE DECIMAL ±	COMMENTS:		
		INTERPRET GEOMETRIC TOLERANCING PER:			
		MATERIAL			
		FINISH			
NEXT ASSY	USED ON				
APPLICATION	DO NOT SCALE DRAWING				

3" SQUARE ALUMINUM TUBE

TITLE:
GL-P-SGL-MODUP-54W-TW-CG-41K-15X18

SIZE **A** DWG. NO. REV

SCALE: 1:4 WEIGHT: SHEET 10 OF 13

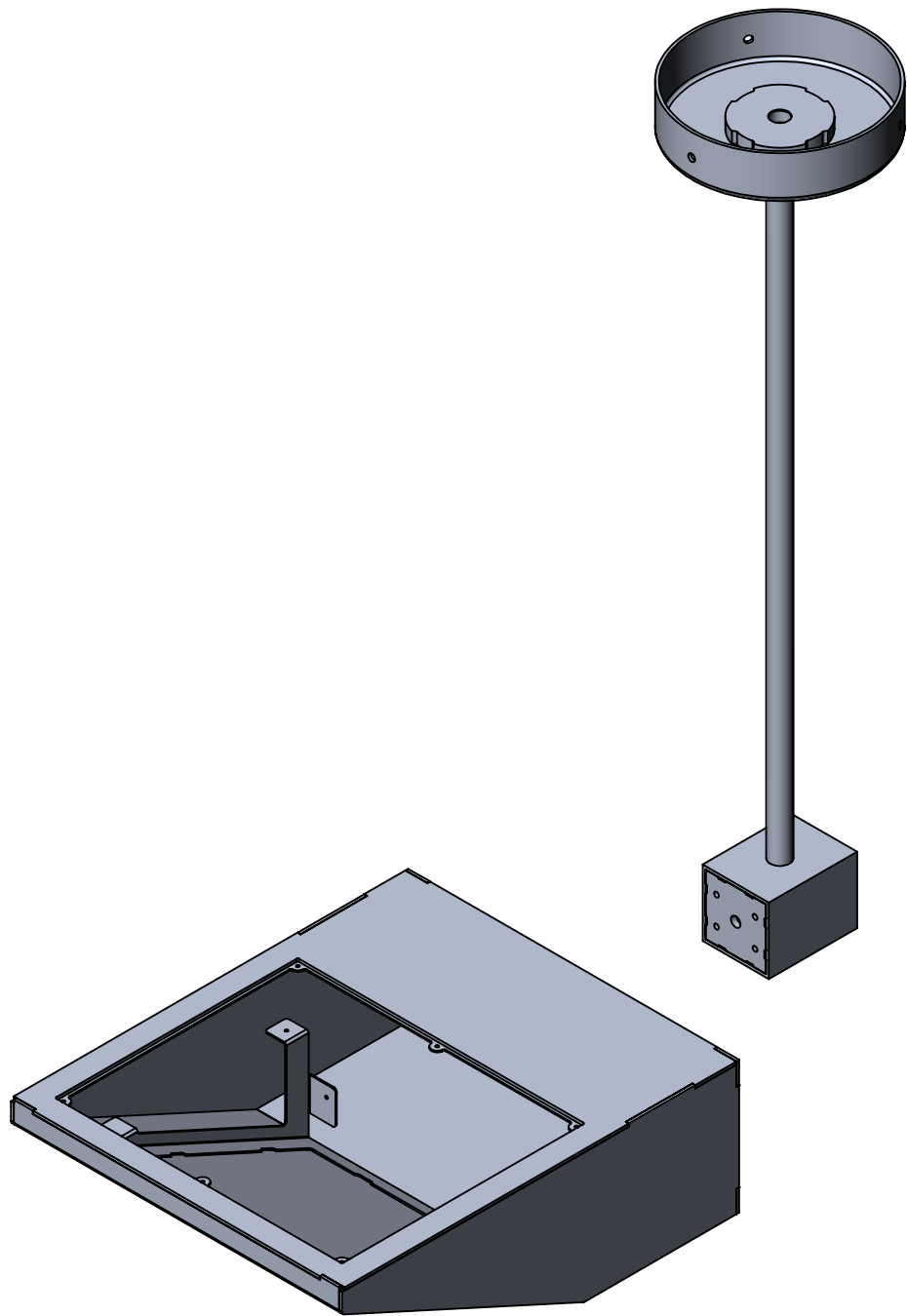

ITEM NO.	PART NUMBER	DESCRIPTION	QTY.
1	GL-P-SGL-MODUP-54W-7-CG-41K-15X18-SPUN CANOPY	SPUN ALUMINUM 0.125"	1

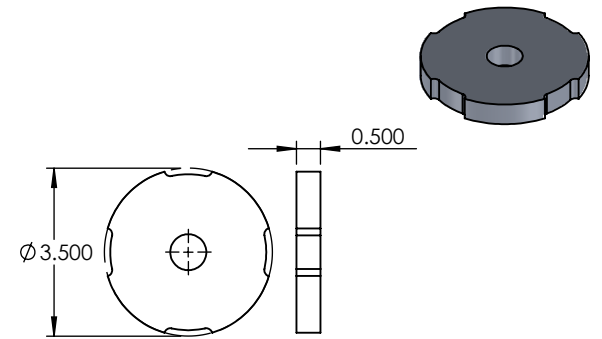
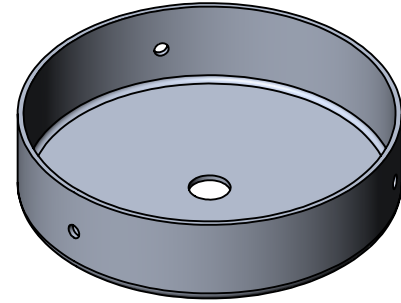
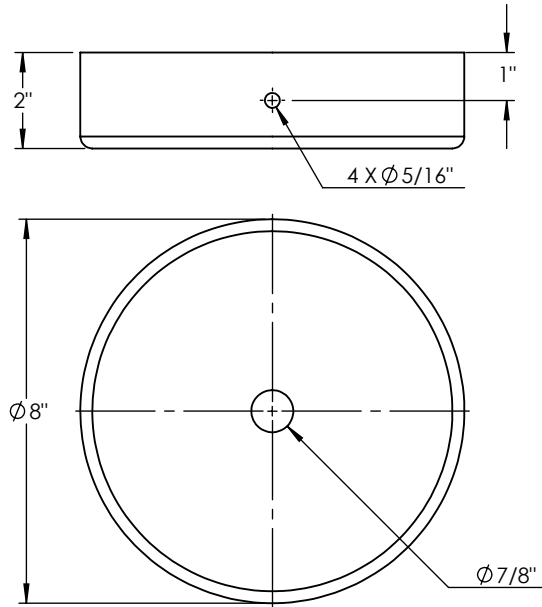
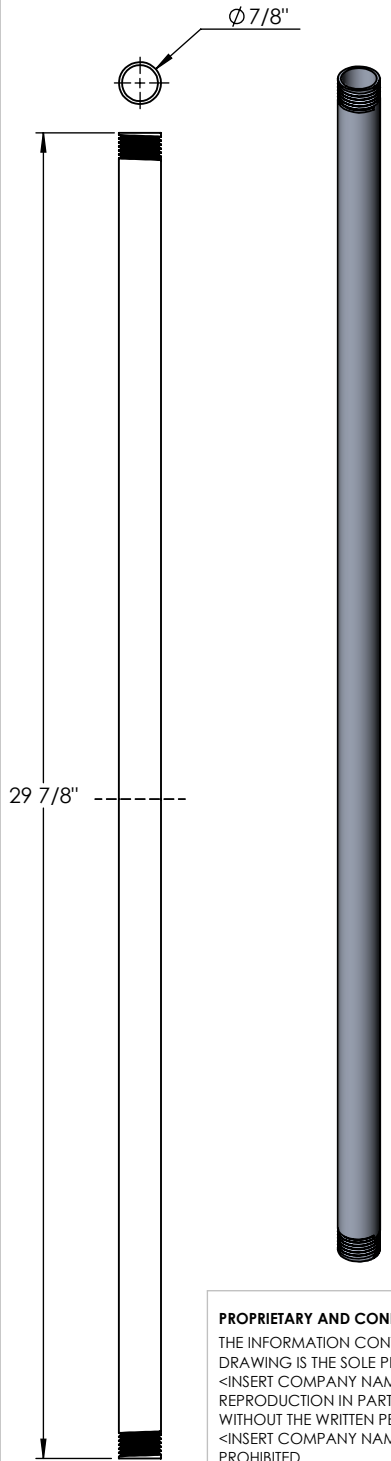

PROPRIETARY AND CONFIDENTIAL
 THE INFORMATION CONTAINED IN THIS DRAWING IS THE SOLE PROPERTY OF <INSERT COMPANY NAME HERE>. ANY REPRODUCTION IN PART OR AS A WHOLE WITHOUT THE WRITTEN PERMISSION OF <INSERT COMPANY NAME HERE> IS PROHIBITED.

		UNLESS OTHERWISE SPECIFIED:	NAME	DATE	SPUN ALUMINUM 0.125"	
		DIMENSIONS ARE IN INCHES	DRAWN		TITLE:	
		TOLERANCES:	CHECKED		GL-P-SGL-MODUP-54W-TW-CG-41K-15X18	
		FRACTIONAL ±	ENG APPR.		SIZE DWG. NO. REV	
		ANGULAR: MACH ± BEND ±	MFG APPR.		A	
		TWO PLACE DECIMAL ±	Q.A.		SCALE: 1:4 WEIGHT: SHEET 12 OF 13	
		THREE PLACE DECIMAL ±	COMMENTS:			
		INTERPRET GEOMETRIC TOLERANCING PER:				
		MATERIAL				
NEXT ASSY	USED ON	FINISH				
APPLICATION		DO NOT SCALE DRAWING				

5

4

3

2

1

ITEM NO.	PART NUMBER	DESCRIPTION	QTY.
1	GL-P-SGL-MODUP-54W-7-CG-41K-15X18-SPUN FIREPLATE	SPUN ALUMINUM 0.125"	1

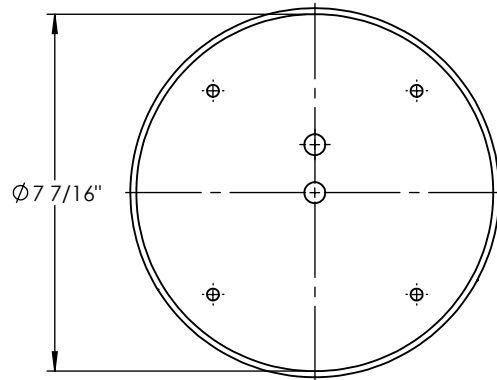
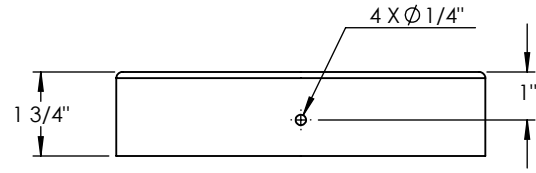
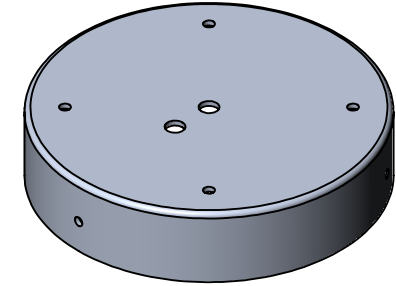

<p>PROPRIETARY AND CONFIDENTIAL THE INFORMATION CONTAINED IN THIS DRAWING IS THE SOLE PROPERTY OF <INSERT COMPANY NAME HERE>. ANY REPRODUCTION IN PART OR AS A WHOLE WITHOUT THE WRITTEN PERMISSION OF <INSERT COMPANY NAME HERE> IS PROHIBITED.</p>			UNLESS OTHERWISE SPECIFIED:		NAME	DATE	SPUN ALUMINUM 0.125"	
			DIMENSIONS ARE IN INCHES TOLERANCES: FRACTIONAL ± ANGULAR: MACH ± BEND ± TWO PLACE DECIMAL ± THREE PLACE DECIMAL ±	DRAWN			TITLE:	
			INTERPRET GEOMETRIC TOLERANCING PER:	CHECKED			GL-P-SGL-MODUP-54W-TW-CG-41K-15X18	
			MATERIAL	ENG APPR.			Q.A.	COMMENTS:
		NEXT ASSY	USED ON	FINISH			SIZE	DWG. NO.
	APPLICATION		DO NOT SCALE DRAWING			SCALE: 1:4	WEIGHT:	SHEET 13 OF 13
5	4	3	2	1				