

ALL BEND RADIUS .030"

APPLICATION

DO NOT SCALE DRAWING

UNLESS OTHERWISE SPECIFIED:

DIMENSIONS ARE IN INCHES
 TOLERANCES:
 FRACTIONAL ± .003
 ANGULAR: MACH ± .01 BEND ±
 TWO PLACE DECIMAL ±
 THREE PLACE DECIMAL ± .001

INTERPRET GEOMETRIC
 TOLERANCING PER:

MATERIAL

FINISH

NAME

DATE

DRAWN

CHECKED

ENG APPR.

MFG APPR.

Q.A.

COMMENTS:

TITLE:

NEEL-BOL-20LED-TBK-OA-30K

SIZE DWG. NO.

REV

A TICKET 25756

SCALE: 1:10 WEIGHT:

SHEET 1 OF 11

5

4

3

2

1

ITEM NO.	PART NUMBER	DESCRIPTION	QTY.	CUT
1	NEEL-BOL-20LED-TBK-OA-30K-CYLINDER BODY	8" DIAMETER CYLINDER	1	
2	NEEL-BOL-20LED-TBK-OA-30K-SPUN ANCHOR COVER	SPUN ALUMINUM 0.080"	2	
3	NEEL-BOL-20LED-TBK-OA-30K-ANCHOR COVER BRACKET	ALUMINUM 0.0635"	2	
4	NEEL-BOL-20LED-TBK-OA-30K-DRIVER BRACKET	ALUMINUM 0.0635"	1	
5	NEEL-BOL-20LED-TBK-OA-30K-HEAD PLATE 1	ALUMINUM 0.125" PLATE	6	
6	NEEL-BOL-20LED-TBK-OA-30K-HEAD PLATE 2	ALUMINUM 0.125" PLATE	1	
7	NEEL-BOL-20LED-TBK-OA-30K-HEAD PLATE 3	ALUMINUM 0.125" PLATE	1	
8	NEEL-BOL-20LED-TBK-OA-30K-HEAD PLATE 5	ALUMINUM 0.125" PLATE	1	
9	NEEL-BOL-20LED-TBK-OA-30K-HEAD PLATE 4	ALUMINUM 0.250" PLATE	1	
10	NEEL-BOL-20LED-TBK-OA-30K-TUBE FLANGE	ALUMINUM 0.250" PLATE	1	
11	NEEL-BOL-20LED-TBK-OA-30K-BASE ANCHOR PLATE	ALUMINUM 0.500" PLATE	1	
12	NEEL-BOL-20LED-TBK-OA-30K-SQUARE TUBE	1" SQUARE ALUMINUM TUBE	1	
13	NEEL-BOL-20LED-TBK-OA-30K-ACRYLIC	ACRYLIC	1	
14	ESPEN VEL29070MVH-1	DRIVER	1	
15	AltalLED_PN1010_RevD	LED	4	
16	8-32 SS Hex Drive Flat Head	8-32 FLAT HEAD SCREW	3	

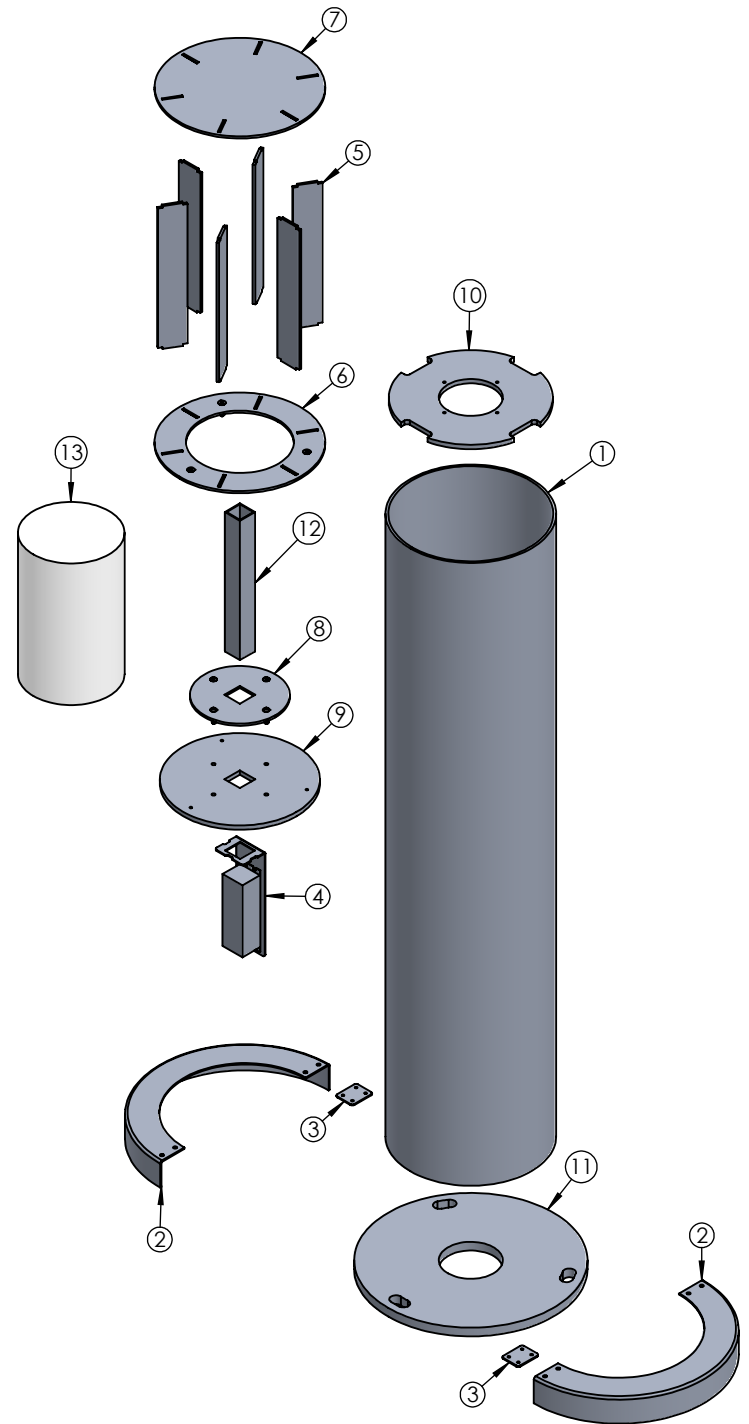

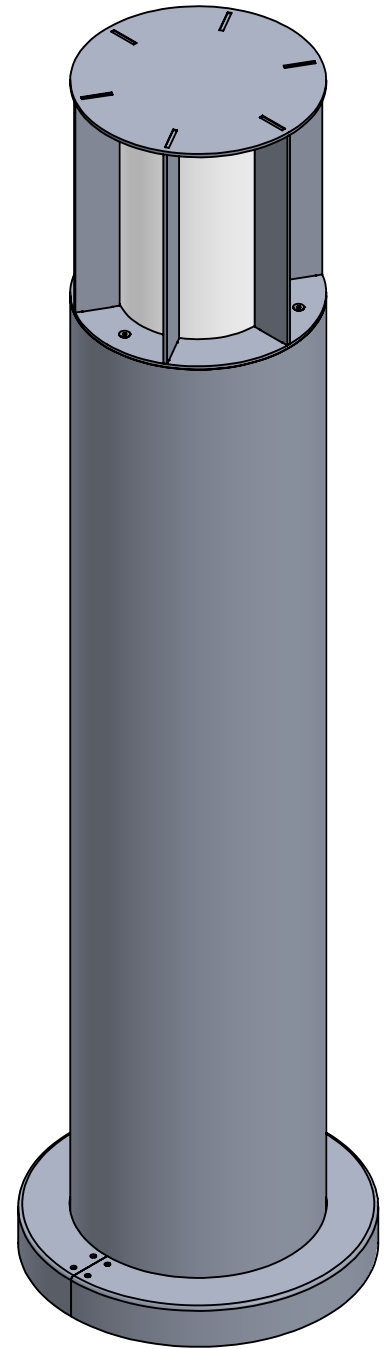
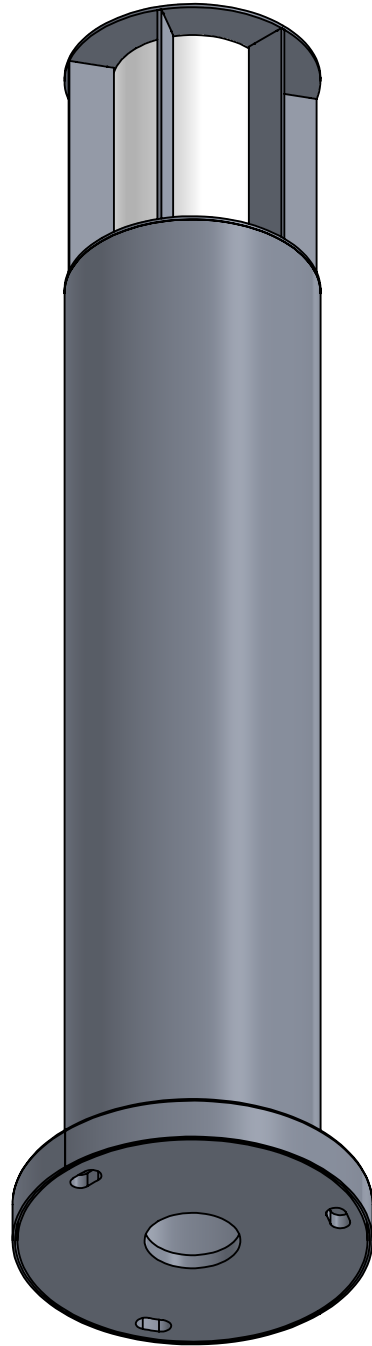
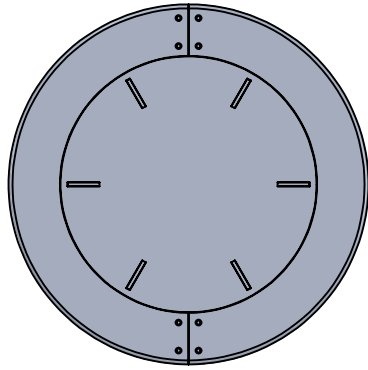
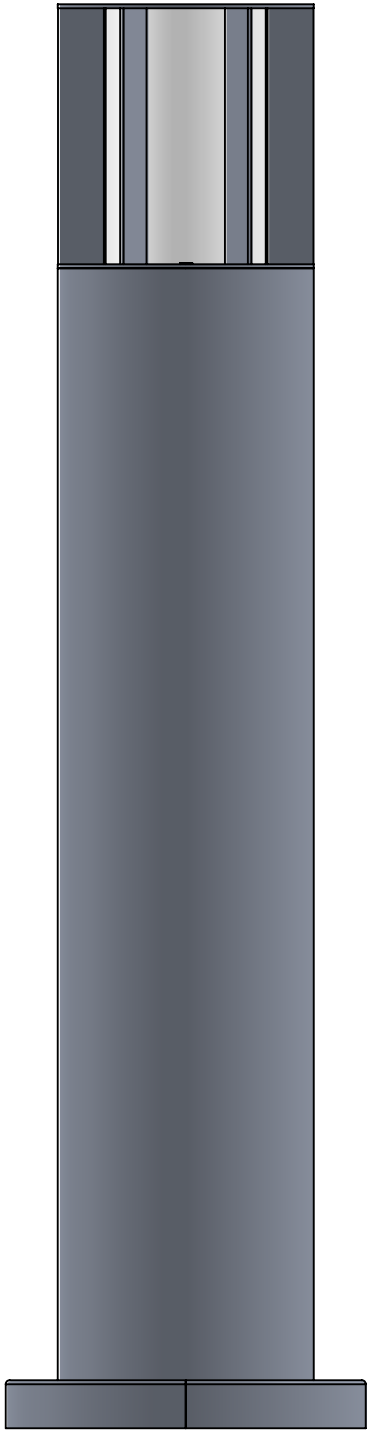

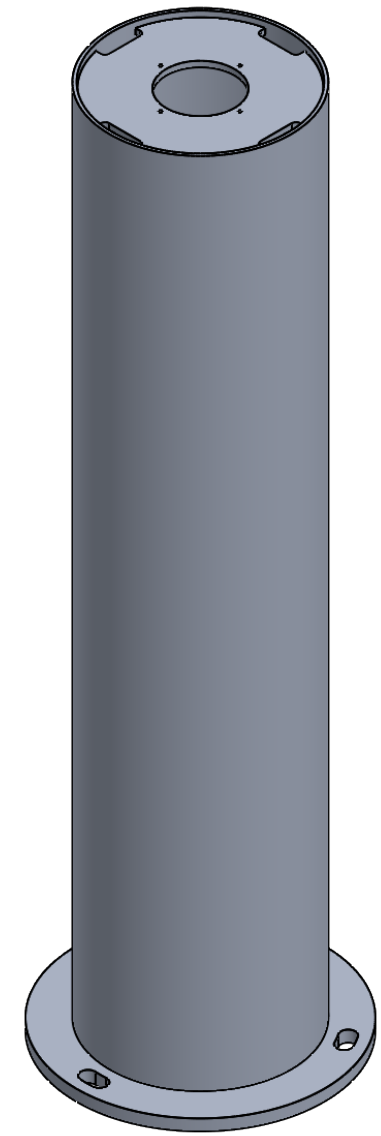
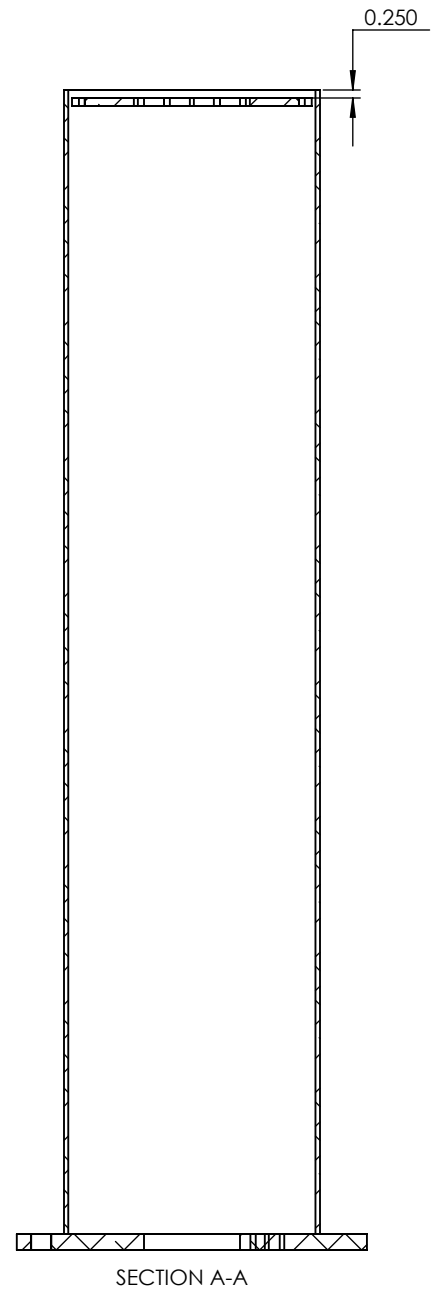
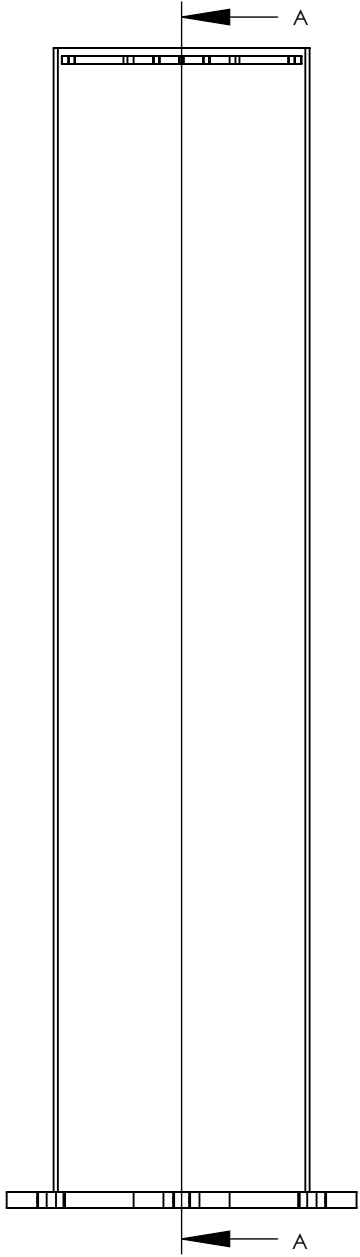

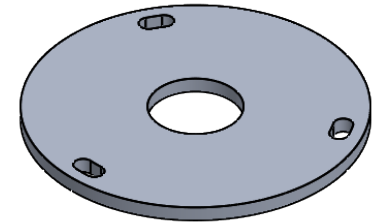
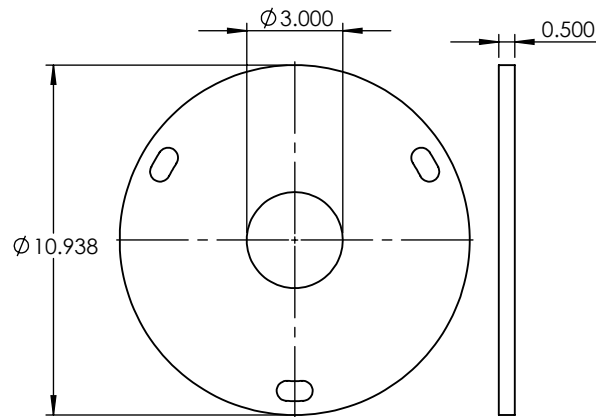
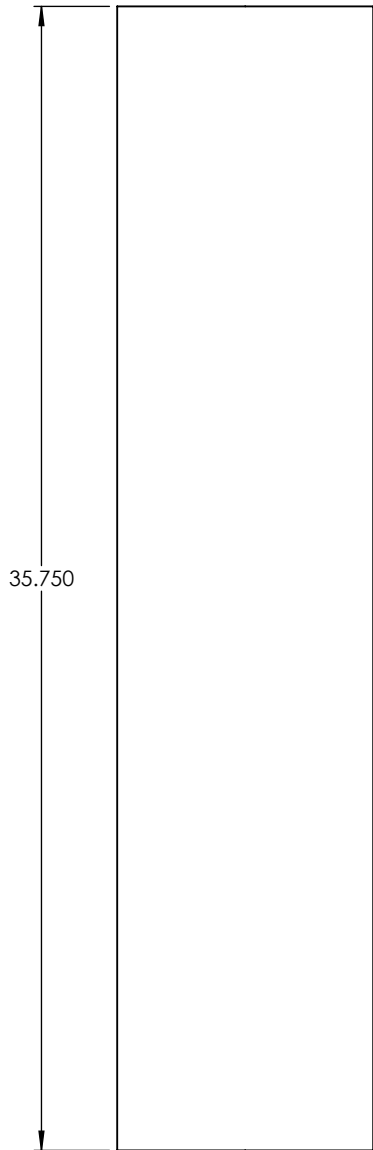
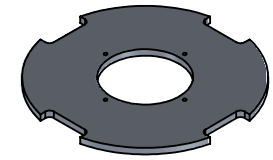
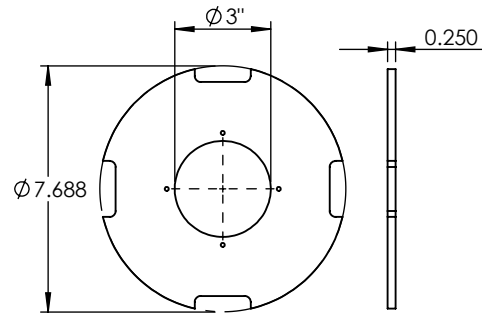
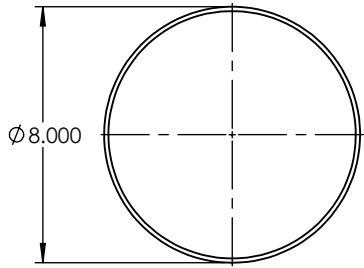

UNLESS OTHERWISE SPECIFIED:		NAME	DATE	8" DIAMETER CYLINDER	
DIMENSIONS ARE IN INCHES		DRAWN		TITLE: NEEL-BOL-20LED-TBK-OA-30K	
TOLERANCES:		CHECKED			
FRACTIONAL \pm		ENG APPR.			
ANGULAR: MACH \pm BEND \pm		MFG APPR.			
TWO PLACE DECIMAL \pm		Q.A.		SIZE	DWG. NO.
THREE PLACE DECIMAL \pm		COMMENTS:		A	
INTERPRET GEOMETRIC TOLERANCING PER:				SCALE: 1:6	WEIGHT:
MATERIAL					SHEET 5 OF 11
FINISH					
DO NOT SCALE DRAWING					

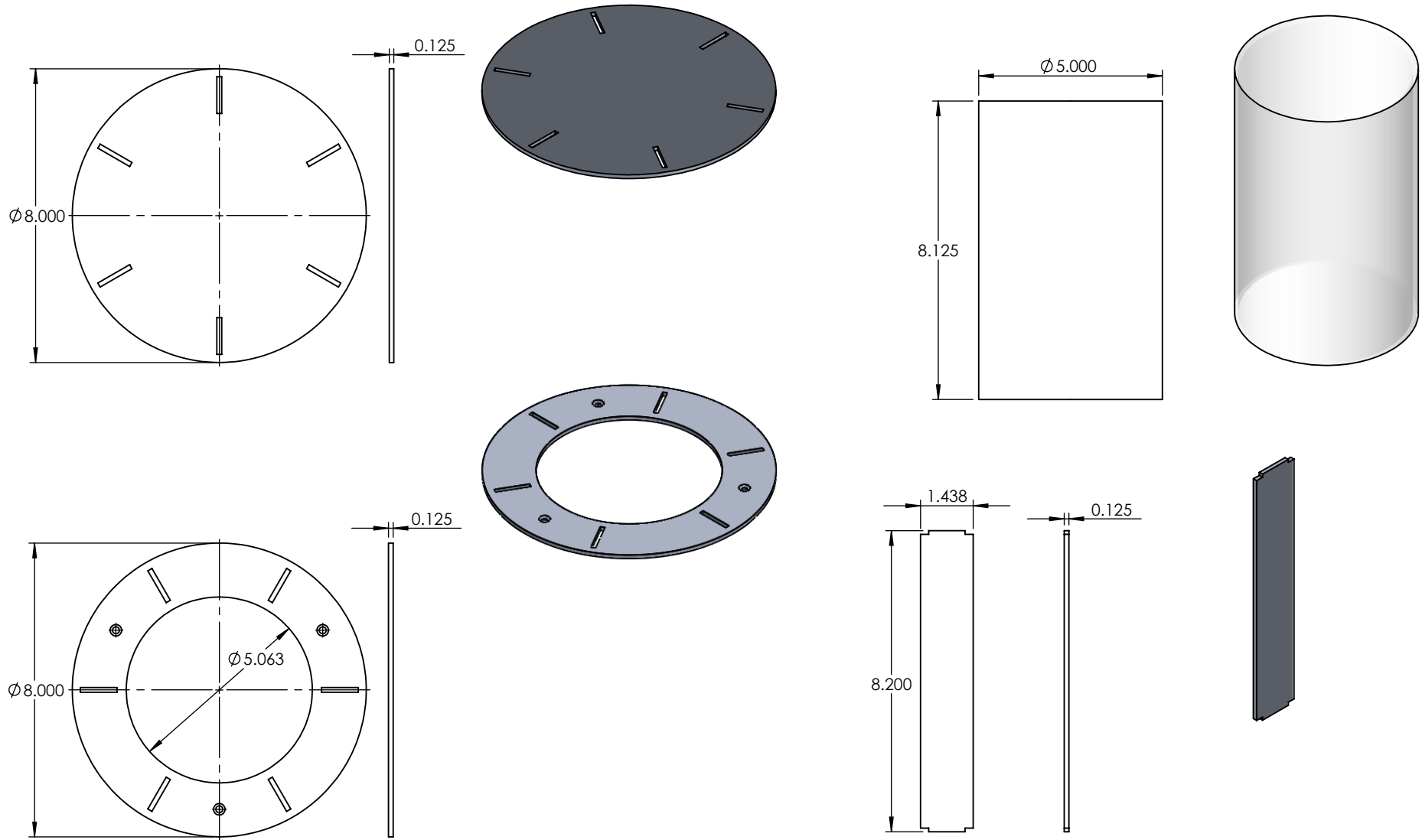

PROPRIETARY AND CONFIDENTIAL
 THE INFORMATION CONTAINED IN THIS DRAWING IS THE SOLE PROPERTY OF <INSERT COMPANY NAME HERE>. ANY REPRODUCTION IN PART OR AS A WHOLE WITHOUT THE WRITTEN PERMISSION OF <INSERT COMPANY NAME HERE> IS PROHIBITED.

		UNLESS OTHERWISE SPECIFIED:		NAME	DATE
		DIMENSIONS ARE IN INCHES		DRAWN	
		TOLERANCES:		CHECKED	
		FRACTIONAL ±		ENG APPR.	
		ANGULAR: MACH ± BEND ±		MFG APPR.	
		TWO PLACE DECIMAL ±		Q.A.	
		THREE PLACE DECIMAL ±		COMMENTS:	
		INTERPRET GEOMETRIC TOLERANCING PER:			
		MATERIAL			
		FINISH			
NEXT ASSY	USED ON				
APPLICATION		DO NOT SCALE DRAWING			

ALUMINUM 0.125" PLATE		
TITLE:		
NEEL-BOL-20LED-TBK-OA-30K		
SIZE	DWG. NO.	REV
A		
SCALE: 1:4	WEIGHT:	SHEET 6 OF 11

5

4

3

2

1

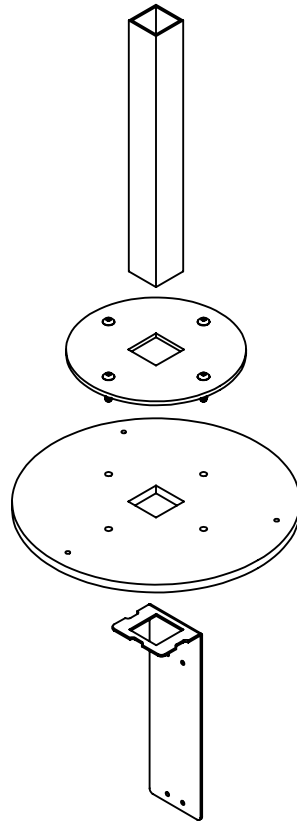
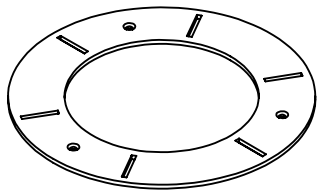
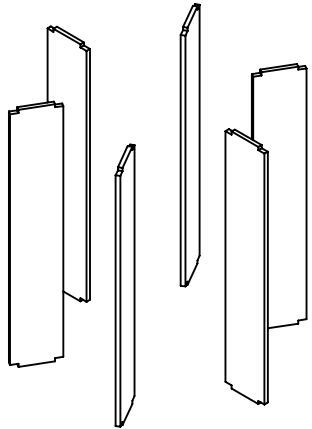
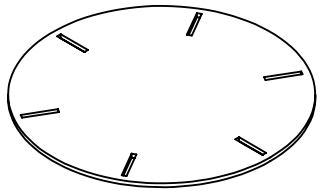
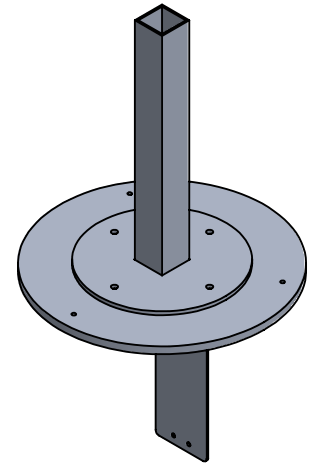
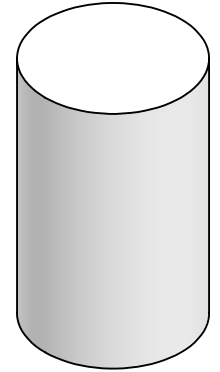
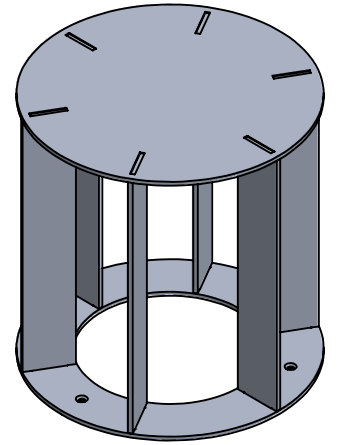
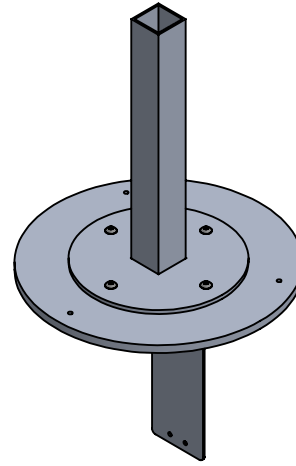
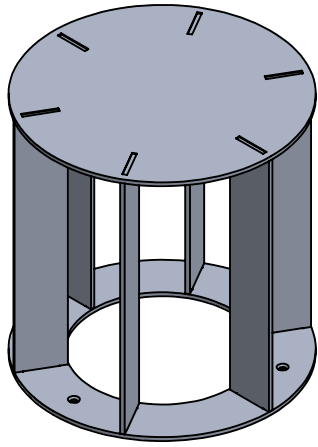

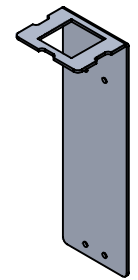
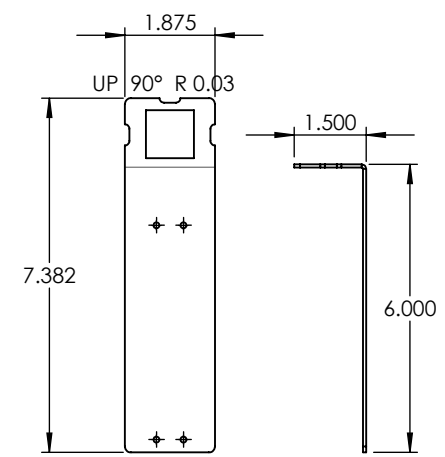
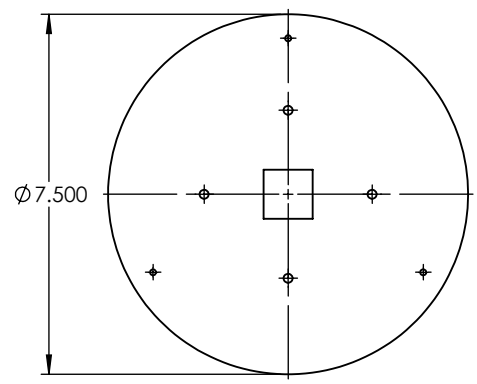
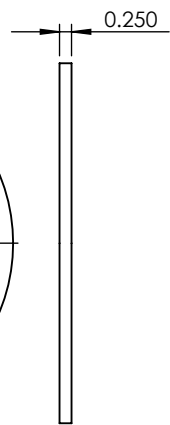
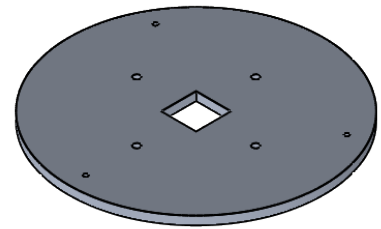
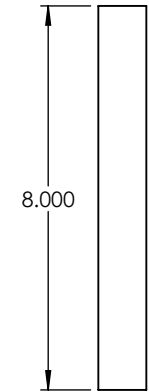
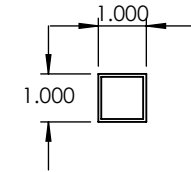
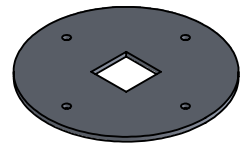
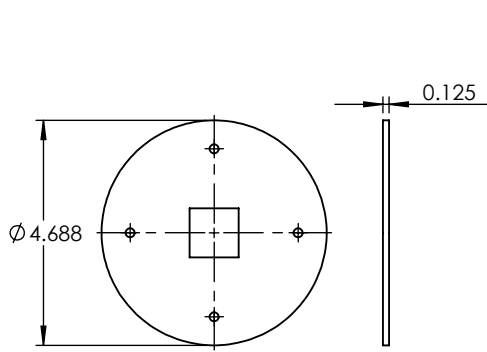

PROPRIETARY AND CONFIDENTIAL
 THE INFORMATION CONTAINED IN THIS DRAWING IS THE SOLE PROPERTY OF <INSERT COMPANY NAME HERE>. ANY REPRODUCTION IN PART OR AS A WHOLE WITHOUT THE WRITTEN PERMISSION OF <INSERT COMPANY NAME HERE> IS PROHIBITED.

		UNLESS OTHERWISE SPECIFIED:		NAME	DATE
		DIMENSIONS ARE IN INCHES	DRAWN		
		TOLERANCES:	CHECKED		
		FRACTIONAL ±	ENG APPR.		
		ANGULAR: MACH ± BEND ±	MFG APPR.		
		TWO PLACE DECIMAL ±	Q.A.		
		THREE PLACE DECIMAL ±	COMMENTS:		
		INTERPRET GEOMETRIC TOLERANCING PER:			
		MATERIAL			
		FINISH			
NEXT ASSY	USED ON				
APPLICATION	DO NOT SCALE DRAWING				

ALUMINUM 0.0635"		
TITLE:		
NEEL-BOL-20LED-TBK-OA-30K		
SIZE	DWG. NO.	REV
A		
SCALE: 1:4	WEIGHT:	SHEET 8 OF 11

ITEM NO.	PART NUMBER	DESCRIPTION	QTY.
1	NEEL-BOL-20LED-TBK-OA-30K-SPUN ANCHOR COVER	SPUN ALUMINUM 0.080"	1

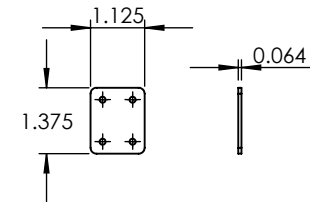
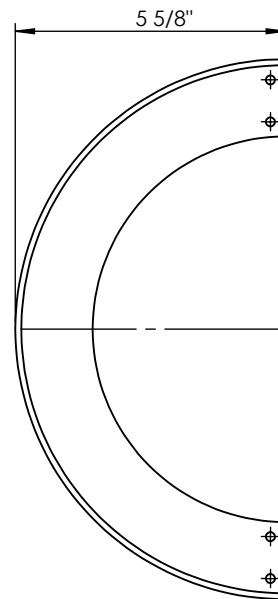
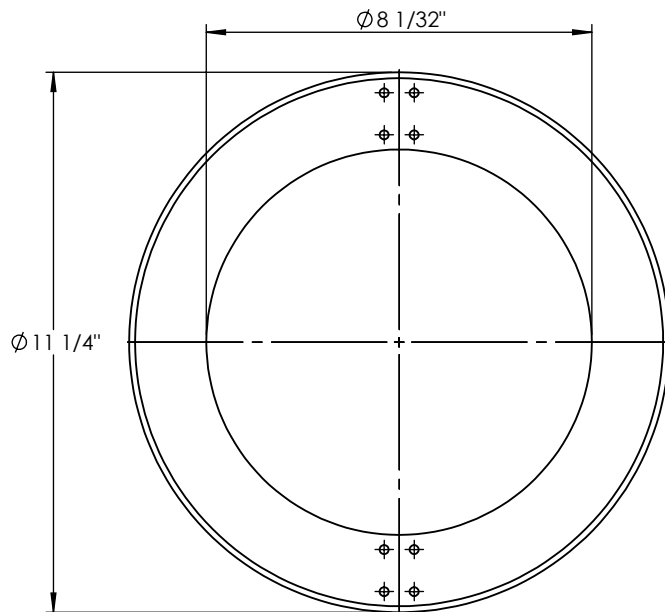
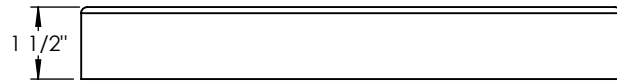
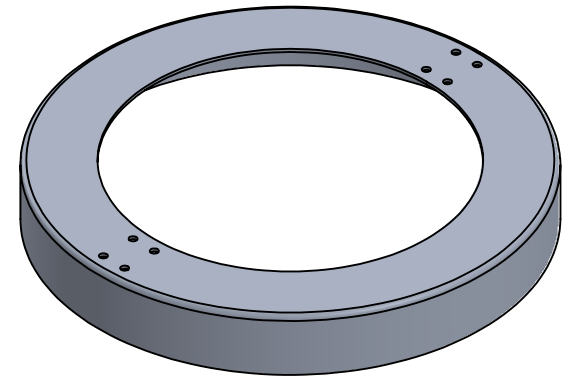

PROPRIETARY AND CONFIDENTIAL
 THE INFORMATION CONTAINED IN THIS DRAWING IS THE SOLE PROPERTY OF <INSERT COMPANY NAME HERE>. ANY REPRODUCTION IN PART OR AS A WHOLE WITHOUT THE WRITTEN PERMISSION OF <INSERT COMPANY NAME HERE> IS PROHIBITED.

UNLESS OTHERWISE SPECIFIED:		NAME	DATE
DIMENSIONS ARE IN INCHES		DRAWN	
TOLERANCES:		CHECKED	
FRACTIONAL ±		ENG APPR.	
ANGULAR: MACH ± BEND ±		MFG APPR.	
TWO PLACE DECIMAL ±		Q.A.	
THREE PLACE DECIMAL ±		COMMENTS:	
INTERPRET GEOMETRIC TOLERANCING PER:			
MATERIAL			
FINISH			
NEXT ASSY	USED ON		
APPLICATION	DO NOT SCALE DRAWING		

SPUN ALUMINUM 0.080"		
TITLE:		
NEEL-BOL-20LED-TBK-OA-30K		
SIZE	DWG. NO.	REV
A		
SCALE: 1:4	WEIGHT:	SHEET 9 OF 11

5

4

3

2

1

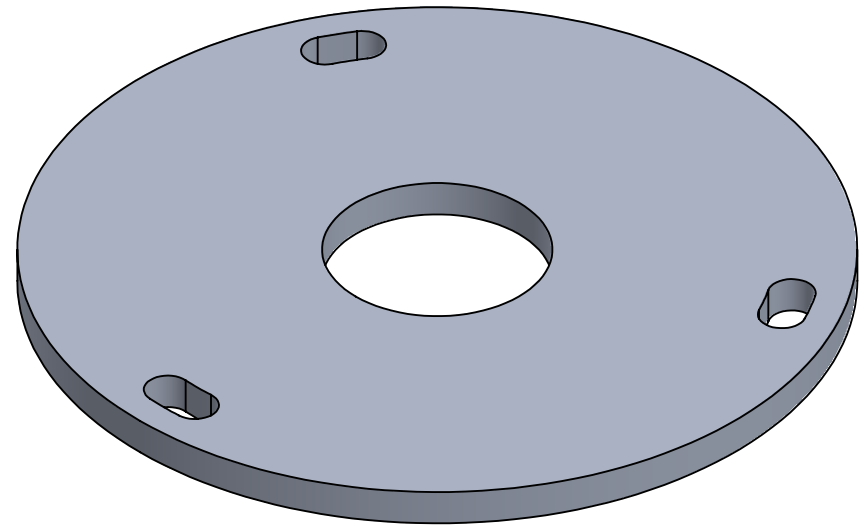
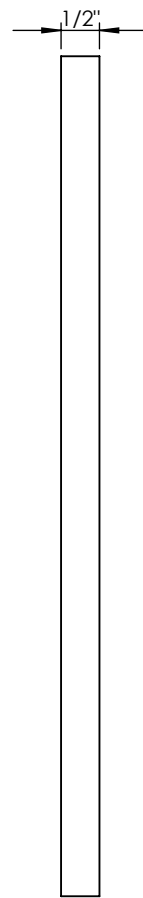
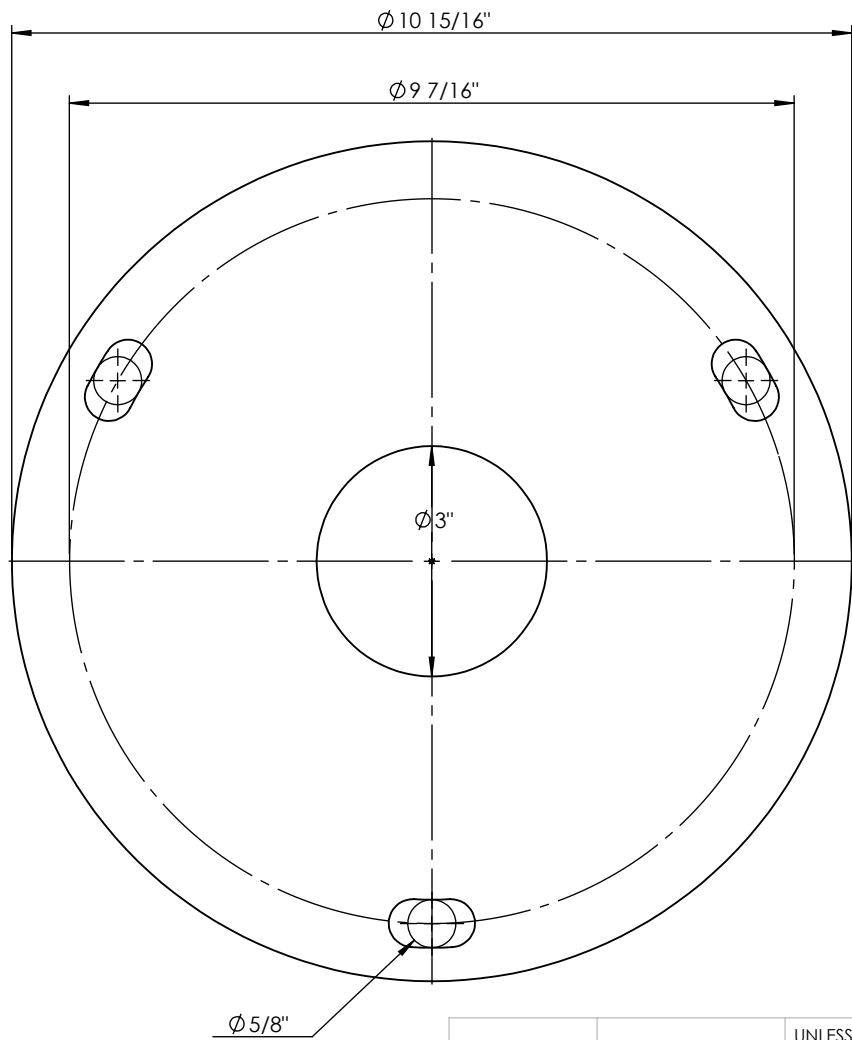

Ø 5/8"

		UNLESS OTHERWISE SPECIFIED:		NAME	DATE
		DIMENSIONS ARE IN INCHES	DRAWN		
		TOLERANCES:	CHECKED		
		FRACTIONAL ±	ENG APPR.		
		ANGULAR: MACH ± BEND ±	MFG APPR.		
		TWO PLACE DECIMAL ±	Q.A.		
		THREE PLACE DECIMAL ±	COMMENTS:		
		INTERPRET GEOMETRIC TOLERANCING PER:			
		MATERIAL			
		FINISH			
NEXT ASSY	USED ON				
APPLICATION		DO NOT SCALE DRAWING			

ALUMINUM 0.500" PLATE		
TITLE:		
NEEL-BOL-20LED-TBK-OA-30K		
SIZE	DWG. NO.	REV
A		
SCALE: 1:2.5WEIGHT:		SHEET 10 OF 11

