

| ITEM NO. | PART NUMBER | DESCRIPTION | QTY. | CUT |
|----------|---|-------------|------|-----|
| 1 | BV-BB-W22"-12W-MN-WF-TBL-DIM-WET-35K-FRAME | 22 GAUGE | 1 | |
| 2 | BV-BB-W22"-12W-MN-WF-TBL-DIM-WET-35K-BACKPLATE | 22 GAUGE | 1 | |
| 3 | BV-BB-W22"-12W-MN-WF-TBL-DIM-WET-35K-FIREPLATE | 22 GAUGE | 1 | |
| 4 | BV-BB-W22"-12W-MN-WF-TBL-DIM-WET-35K-FRAME TAB | 22 GAUGE | 4 | |
| 5 | BV-BB-W22"-12W-MN-WF-TBL-DIM-WET-35K-LONG RAIL | 22 GAUGE | 2 | |
| 6 | BV-BB-W22"-12W-MN-WF-TBL-DIM-WET-35K-SHORT RAIL | 22 GAUGE | 2 | |
| 7 | BV-BB-W22"-12W-MN-WF-TBL-DIM-WET-35K-HORIZONTAL STRAP | 22 GAUGE | 2 | |
| 8 | BV-BB-W22"-12W-MN-WF-TBL-DIM-WET-35K-ACRYLIC | ACRYLIC | 1 | |
| 9 | DS-15W-350C1542010-3001 | DRIVER | 1 | |
| 10 | AlfaLED PN1004RevD | LED | 2 | |

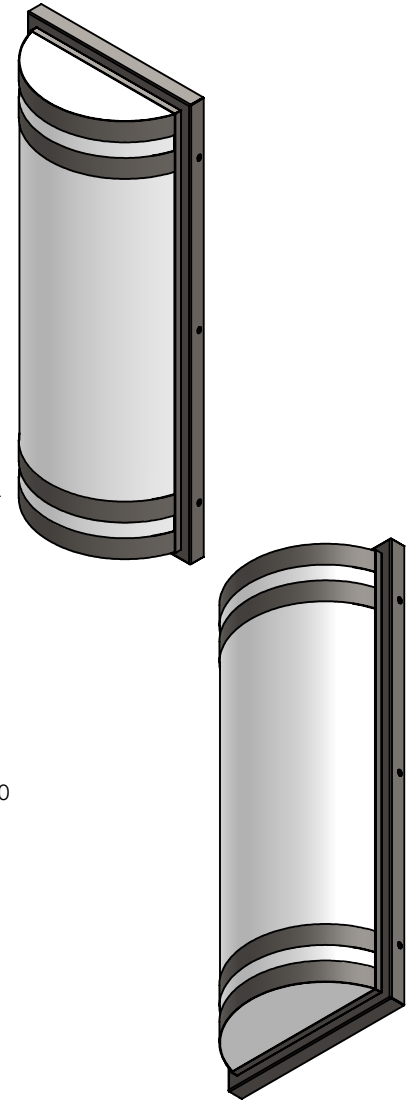

| UNLESS OTHERWISE SPECIFIED: | | NAME | DATE |
|--|---------------------|--------------------------------------|------|
| DIMENSIONS ARE IN INCHES TOLERANCES: FRACTIONAL ± .003 ANGULAR: MACH ± .01 BEND ± TWO PLACE DECIMAL ± THREE PLACE DECIMAL ±.001 | DRAWN | | |
| | CHECKED | | |
| | ENG APPR. | | |
| | MFG APPR. | | |
| INTERPRET GEOMETRIC TOLERANCING PER: | Q.A. | | |
| MATERIAL | COMMENTS: | | |
| FINISH | | | |
| TITLE: | | BV-BB-W22"-12W-MN-WF-TBL-DIM-WET-35K | |
| SIZE | DWG. NO. | REV | |
| A | TICKET 25757 | | |
| SCALE: 1:7.5WEIGHT: | | SHEET 1 OF 7 | |

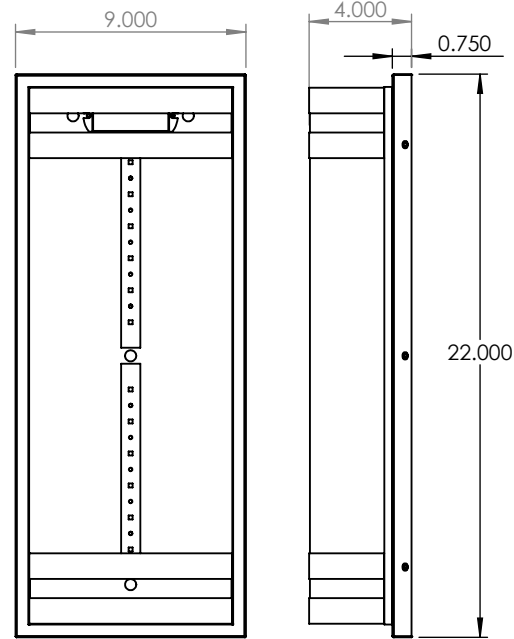
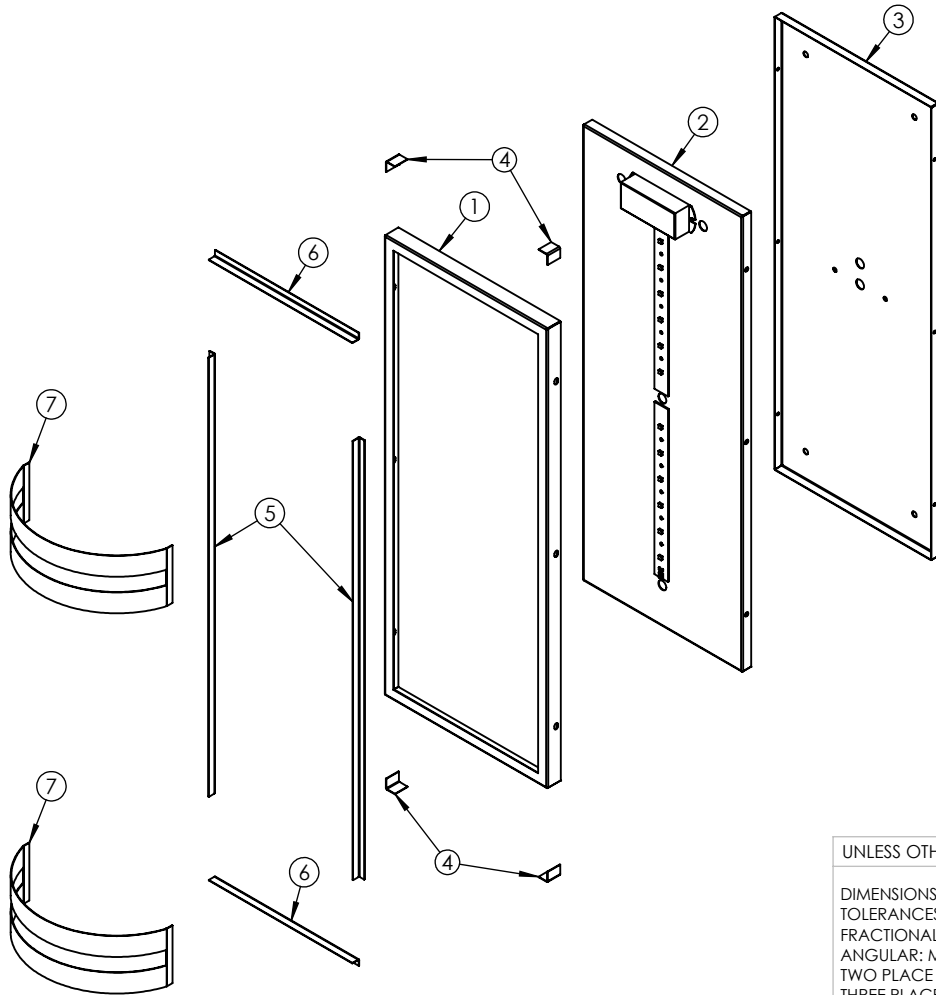

ALL BEND RADIUS .030"

APPLICATION

DO NOT SCALE DRAWING

5

4

3

2

1

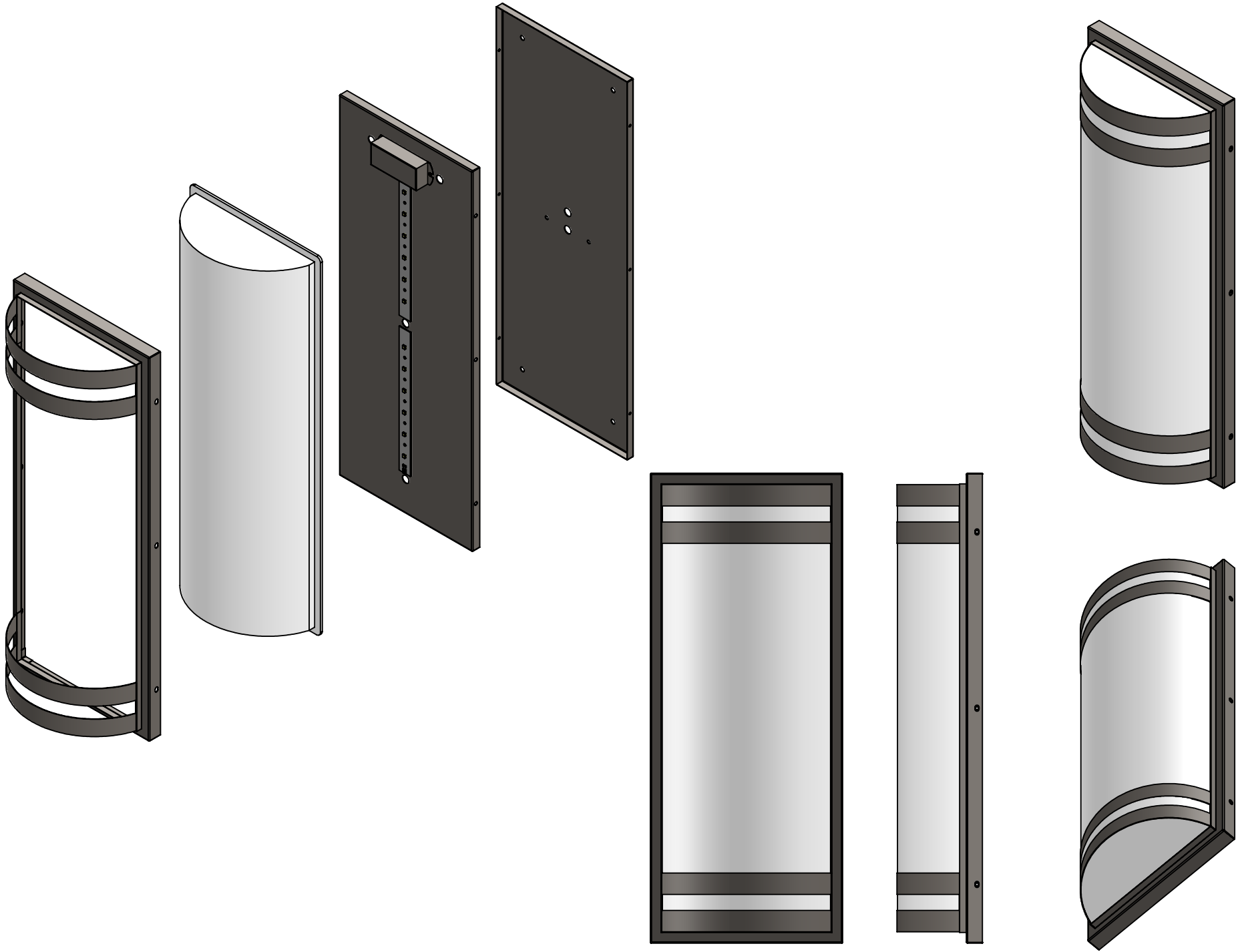

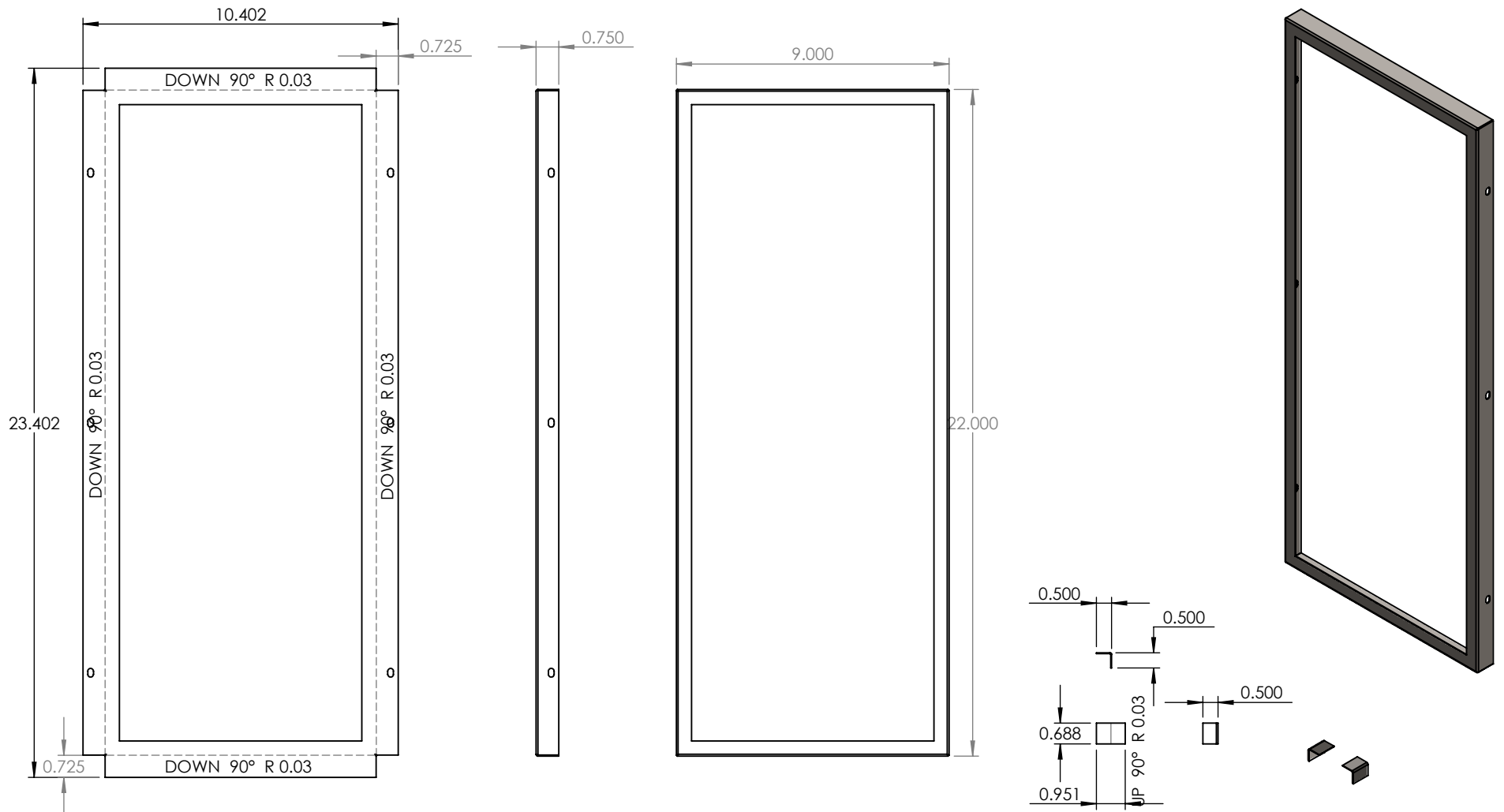

PROPRIETARY AND CONFIDENTIAL
 THE INFORMATION CONTAINED IN THIS DRAWING IS THE SOLE PROPERTY OF <INSERT COMPANY NAME HERE>. ANY REPRODUCTION IN PART OR AS A WHOLE WITHOUT THE WRITTEN PERMISSION OF <INSERT COMPANY NAME HERE> IS PROHIBITED.

| | | | | |
|-------------|---------|--------------------------------------|-----------|------|
| | | UNLESS OTHERWISE SPECIFIED: | NAME | DATE |
| | | DIMENSIONS ARE IN INCHES | DRAWN | |
| | | TOLERANCES: | CHECKED | |
| | | FRACTIONAL ± | ENG APPR. | |
| | | ANGULAR: MACH ± BEND ± | MFG APPR. | |
| | | TWO PLACE DECIMAL ± | Q.A. | |
| | | THREE PLACE DECIMAL ± | COMMENTS: | |
| | | INTERPRET GEOMETRIC TOLERANCING PER: | | |
| | | MATERIAL | | |
| NEXT ASSY | USED ON | FINISH | | |
| APPLICATION | | DO NOT SCALE DRAWING | | |

| | | |
|--------------------------------------|----------|--------------|
| 22 GAUGE | | |
| TITLE: | | |
| BV-BB-W22"-12W-MN-WF-TBL-DIM-WET-35K | | |
| SIZE | DWG. NO. | REV |
| A | | |
| SCALE: 1:5 | WEIGHT: | SHEET 3 OF 7 |

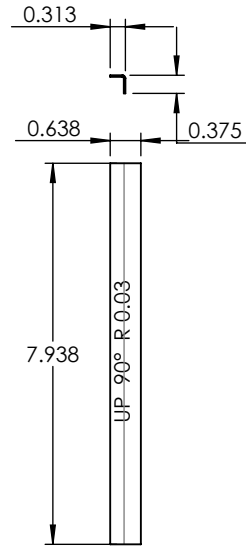
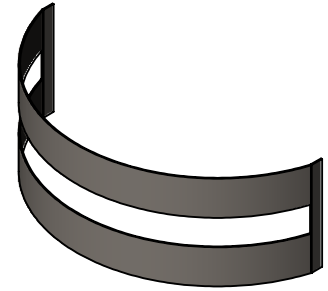
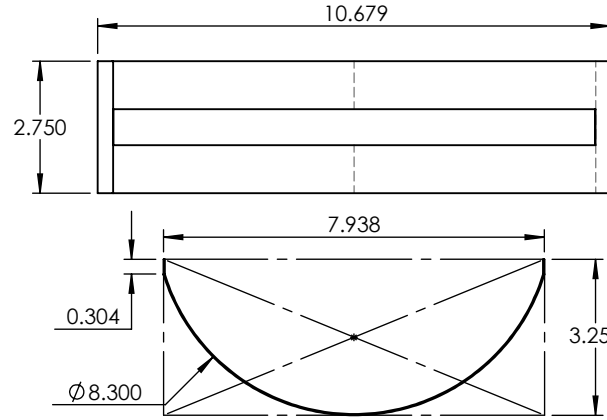
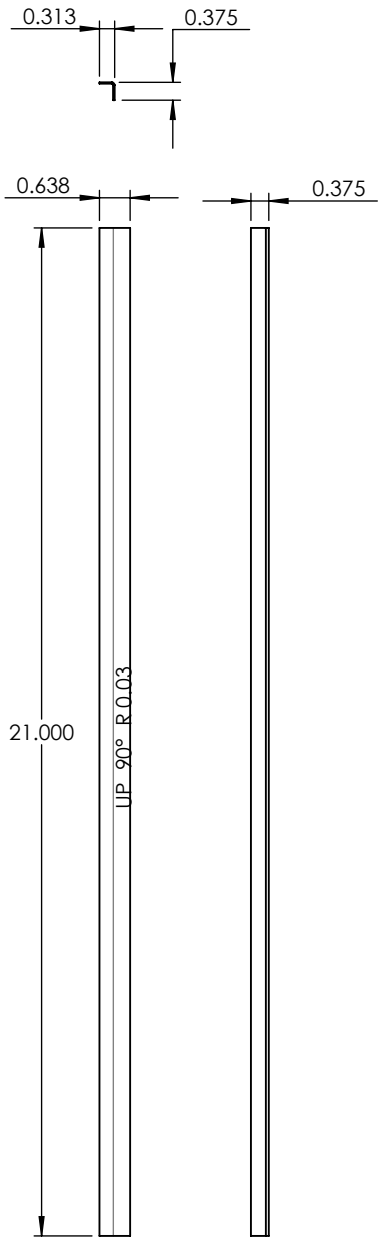

PROPRIETARY AND CONFIDENTIAL
 THE INFORMATION CONTAINED IN THIS DRAWING IS THE SOLE PROPERTY OF <INSERT COMPANY NAME HERE>. ANY REPRODUCTION IN PART OR AS A WHOLE WITHOUT THE WRITTEN PERMISSION OF <INSERT COMPANY NAME HERE> IS PROHIBITED.

| | | | | | | | |
|-------------|---------|---|-----------|------|------|--------------------------------------|----------|
| | | UNLESS OTHERWISE SPECIFIED: | | NAME | DATE | 22 GAUGE | |
| | | DIMENSIONS ARE IN INCHES TOLERANCES: FRACTIONAL ± ANGULAR: MACH ± BEND ± TWO PLACE DECIMAL ± THREE PLACE DECIMAL ± | DRAWN | | | TITLE: | |
| | | INTERPRET GEOMETRIC TOLERANCING PER: | CHECKED | | | BV-BB-W22"-12W-MN-WF-TBL-DIM-WET-35K | |
| | | MATERIAL | ENG APPR. | | | SIZE | DWG. NO. |
| | | FINISH | MFG APPR. | | | A | REV |
| NEXT ASSY | USED ON | | Q.A. | | | SCALE: 1:4 | WEIGHT: |
| APPLICATION | | DO NOT SCALE DRAWING | COMMENTS: | | | SHEET 4 OF 7 | |

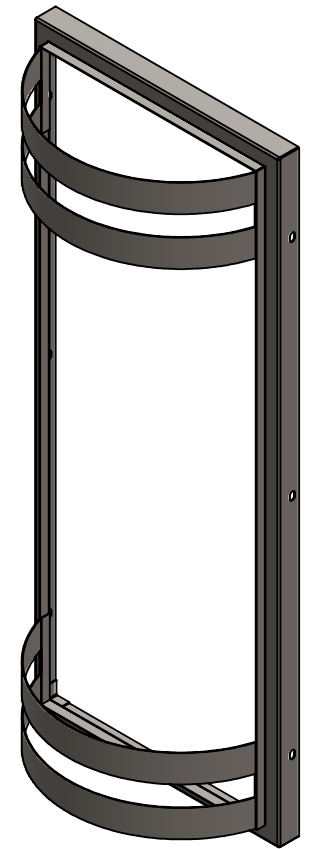
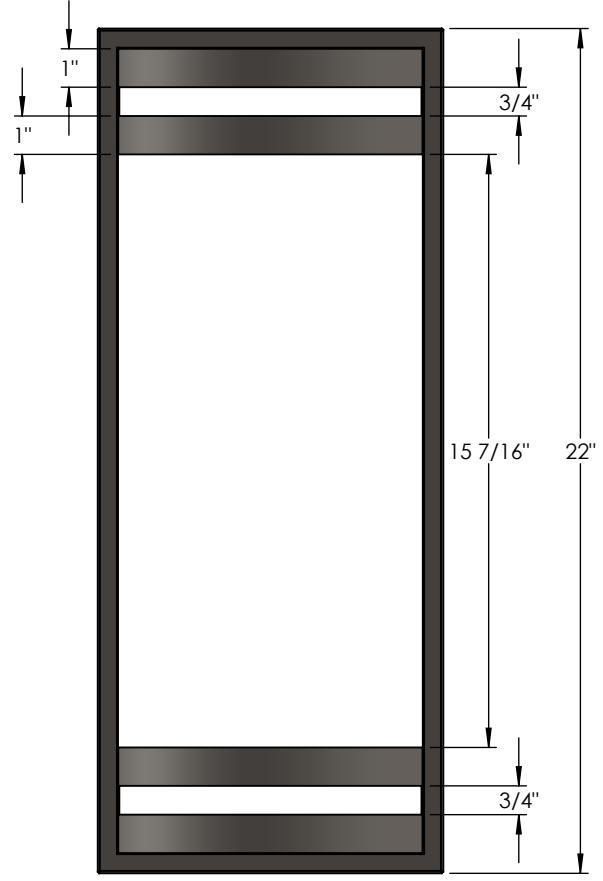
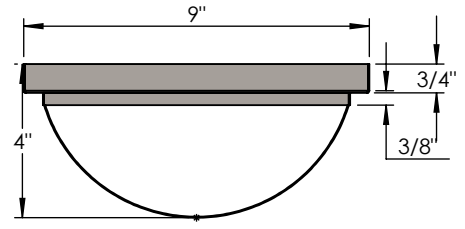
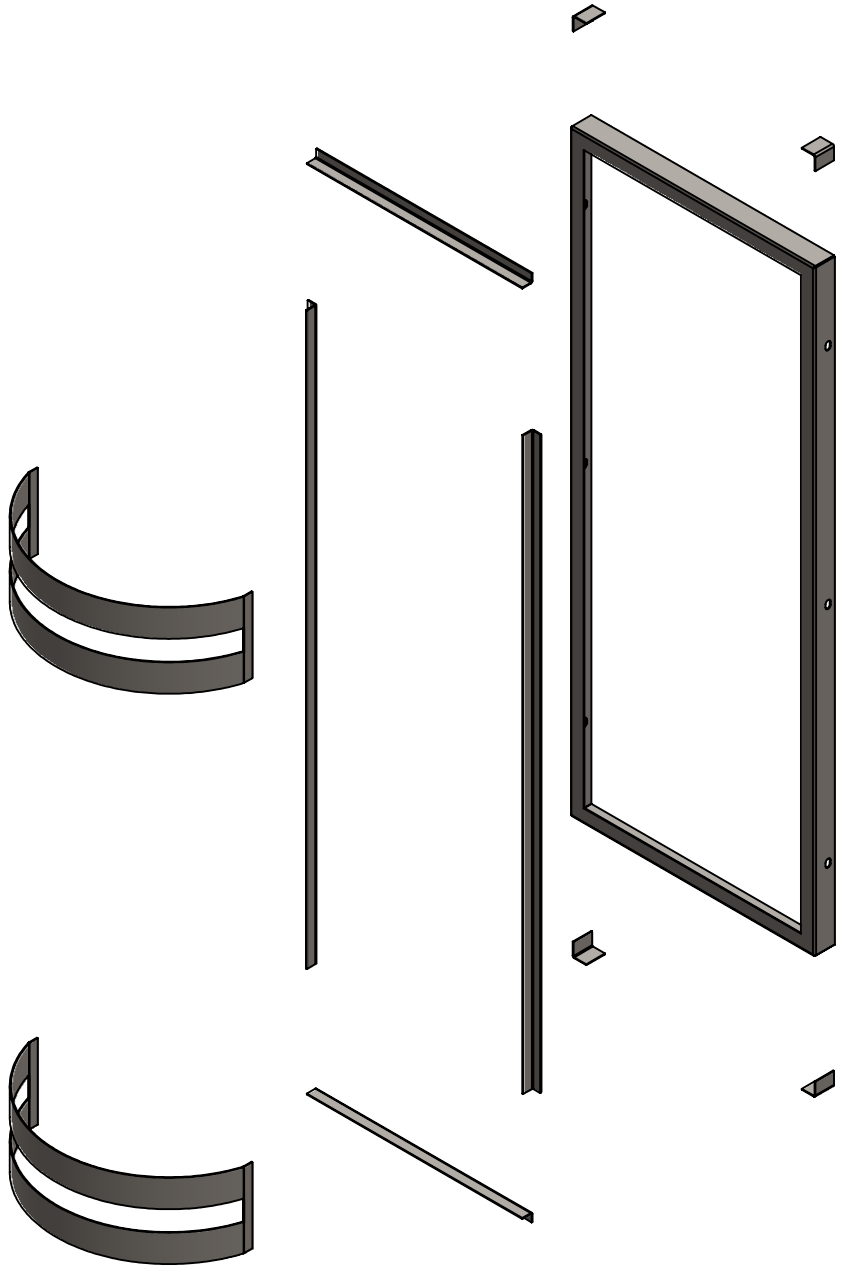

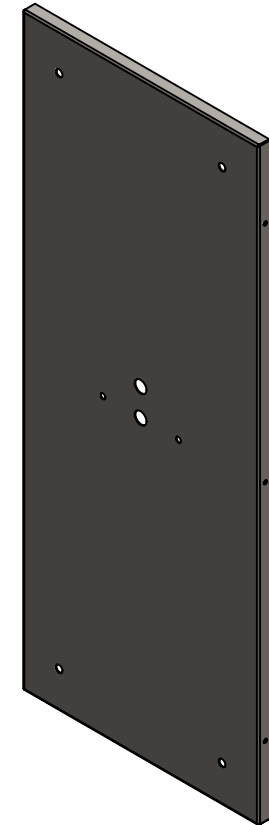
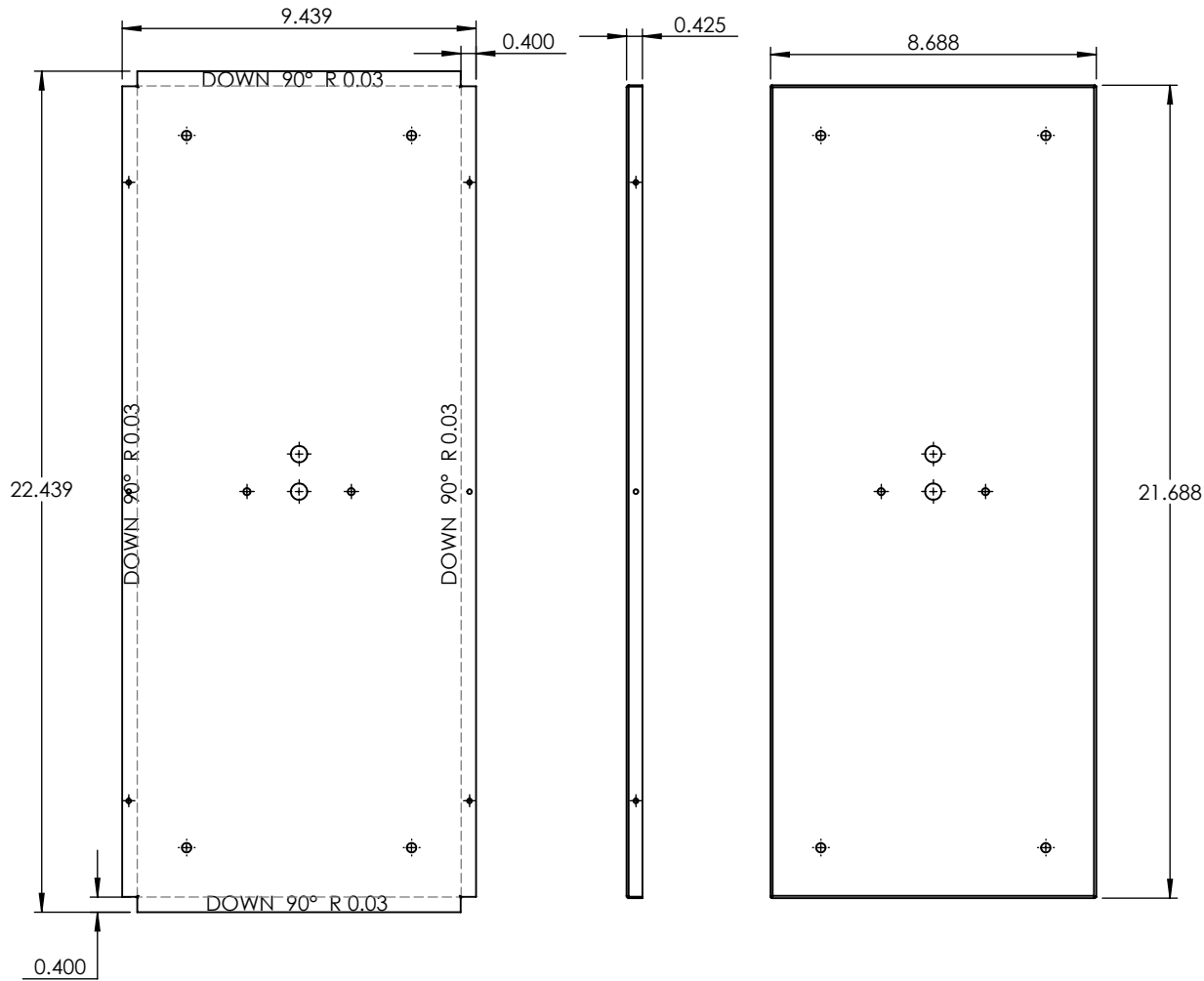

PROPRIETARY AND CONFIDENTIAL
 THE INFORMATION CONTAINED IN THIS DRAWING IS THE SOLE PROPERTY OF <INSERT COMPANY NAME HERE>. ANY REPRODUCTION IN PART OR AS A WHOLE WITHOUT THE WRITTEN PERMISSION OF <INSERT COMPANY NAME HERE> IS PROHIBITED.

| | | | | | | |
|-------------|---------|---|-----------|------|-------------------|--|
| | | UNLESS OTHERWISE SPECIFIED: | NAME | DATE | 22 GAUGE | |
| | | DIMENSIONS ARE IN INCHES TOLERANCES: FRACTIONAL ± ANGULAR: MACH ± BEND ± TWO PLACE DECIMAL ± THREE PLACE DECIMAL ± | DRAWN | | | |
| | | INTERPRET GEOMETRIC TOLERANCING PER: | CHECKED | | SIZE DWG. NO. REV | |
| | | MATERIAL | ENG APPR. | | | |
| NEXT ASSY | USED ON | FINISH | MFG APPR. | Q.A. | | |
| APPLICATION | | DO NOT SCALE DRAWING | COMMENTS: | | | |

5

4

3

2

1