

ITEM NO.	PART NUMBER	DESCRIPTION	QTY.	CUT
1	SHDPF-WL-20W-MN-WF-WET-30K-FRONT ACCENT PLATE	ALUMINUM 0.0635"	1	
2	SHDPF-WL-20W-MN-WF-WET-30K-VERTICAL BAR	1/2"X2" ALUMINUM PLATE	1	
3	SHDPF-WL-20W-MN-WF-WET-30K-PERFORATED HOLE FRAME	ALUMINUM HOLE MESH	1	
4	SHDPF-WL-20W-MN-WF-WET-30K-FRAME PLATE	ALUMINUM 0.0635"	1	
5	SHDPF-WL-20W-MN-WF-WET-30K-BACKPLATE	ALUMINUM 0.0635"	1	
6	SHDPF-WL-20W-MN-WF-WET-30K-FIREPLATE	ALUMINUM 0.0635"	1	
7	SHDPF-WL-20W-MN-WF-WET-30K-DRIVER BRACKET	ALUMINUM 0.0635"	2	
8	SHDPF-WL-20W-MN-WF-WET-30K-INSIDE FLANGE	25 GAUGE	4	
9	SHDPF-WL-20W-MN-WF-WET-30K-ACRYLIC	ACRYLIC	1	
10	SHDPF-WL-20W-MN-WF-WET-30K-TOP ACRYLIC	ACRYLIC	2	
11	AltId_LED_PN1019_SHIM PLATE	ALUMINUM 0.125" PLATE	2	
12	KTLD-25-UV-700-VDIM-LA1	DRIVER	1	
13	AltId_LED_PN1019_RevC	LED	2	

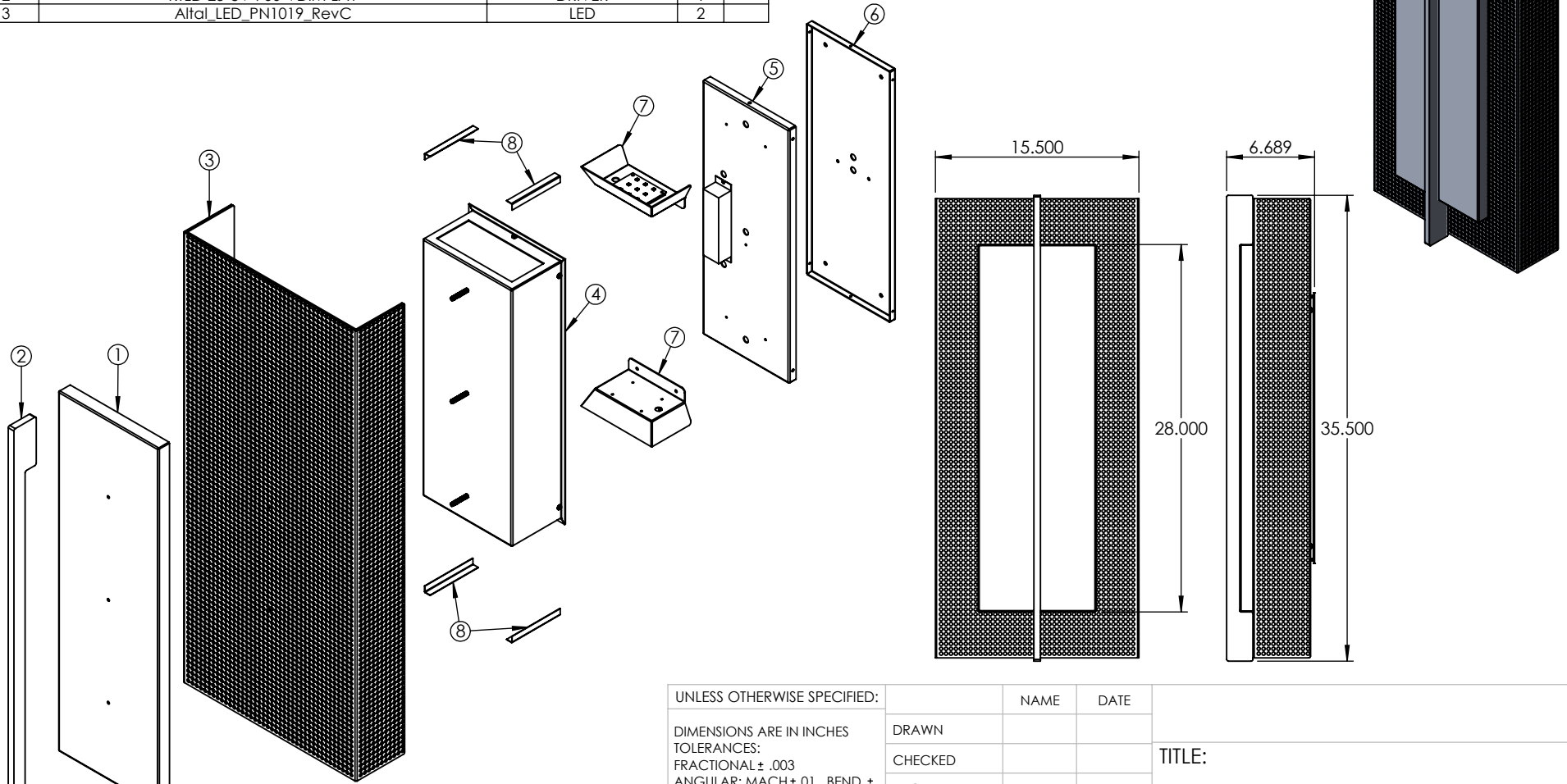

EVERGREEN LIGHTING

ALL BEND RADIUS .030"

APPLICATION

DO NOT SCALE DRAWING

UNLESS OTHERWISE SPECIFIED:

DIMENSIONS ARE IN INCHES
 TOLERANCES:
 FRACTIONAL ± .003
 ANGULAR: MACH ± .01 BEND ±
 TWO PLACE DECIMAL ±
 THREE PLACE DECIMAL ±.001

INTERPRET GEOMETRIC
 TOLERANCING PER:

MATERIAL

FINISH

NAME

DATE

DRAWN

CHECKED

ENG APPR.

MFG APPR.

Q.A.

COMMENTS:

TITLE:

SHDPF-WL-20W-MN-WF-WET-30K

SIZE DWG. NO.

A TICKET 25799

REV

SCALE: 1:10 WEIGHT:

SHEET 1 OF 10

5

4

3

2

1

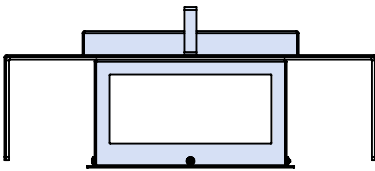
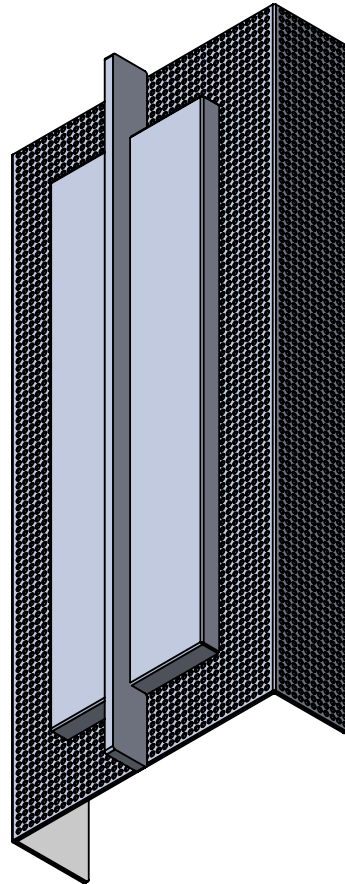
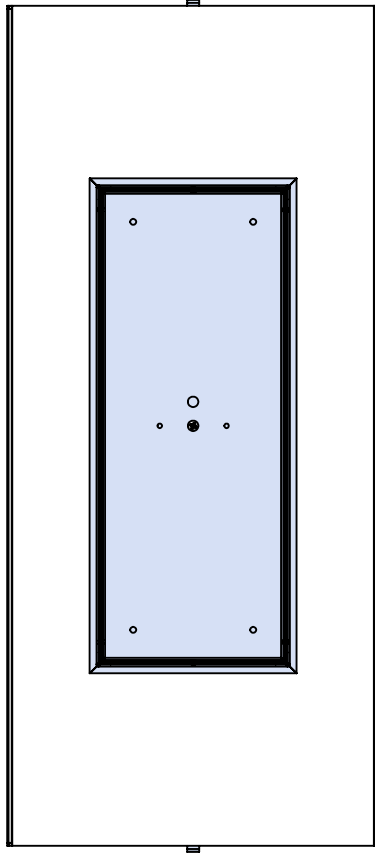
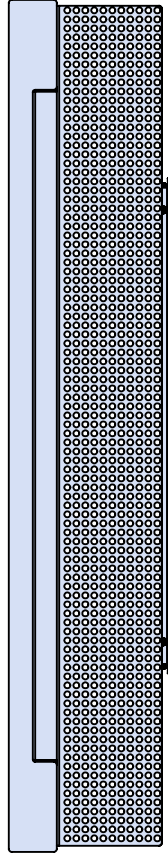
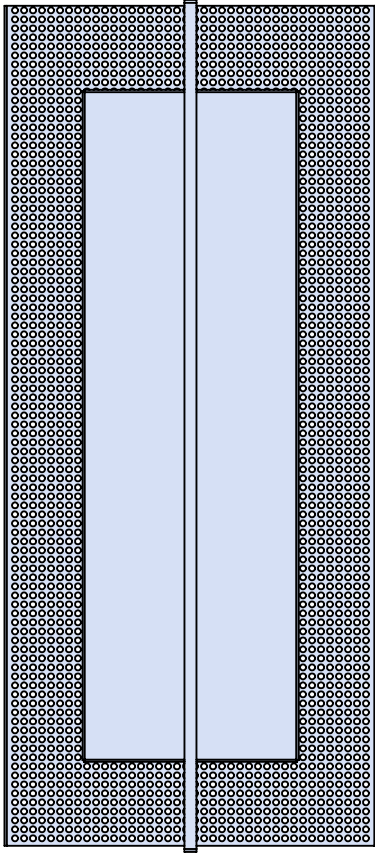

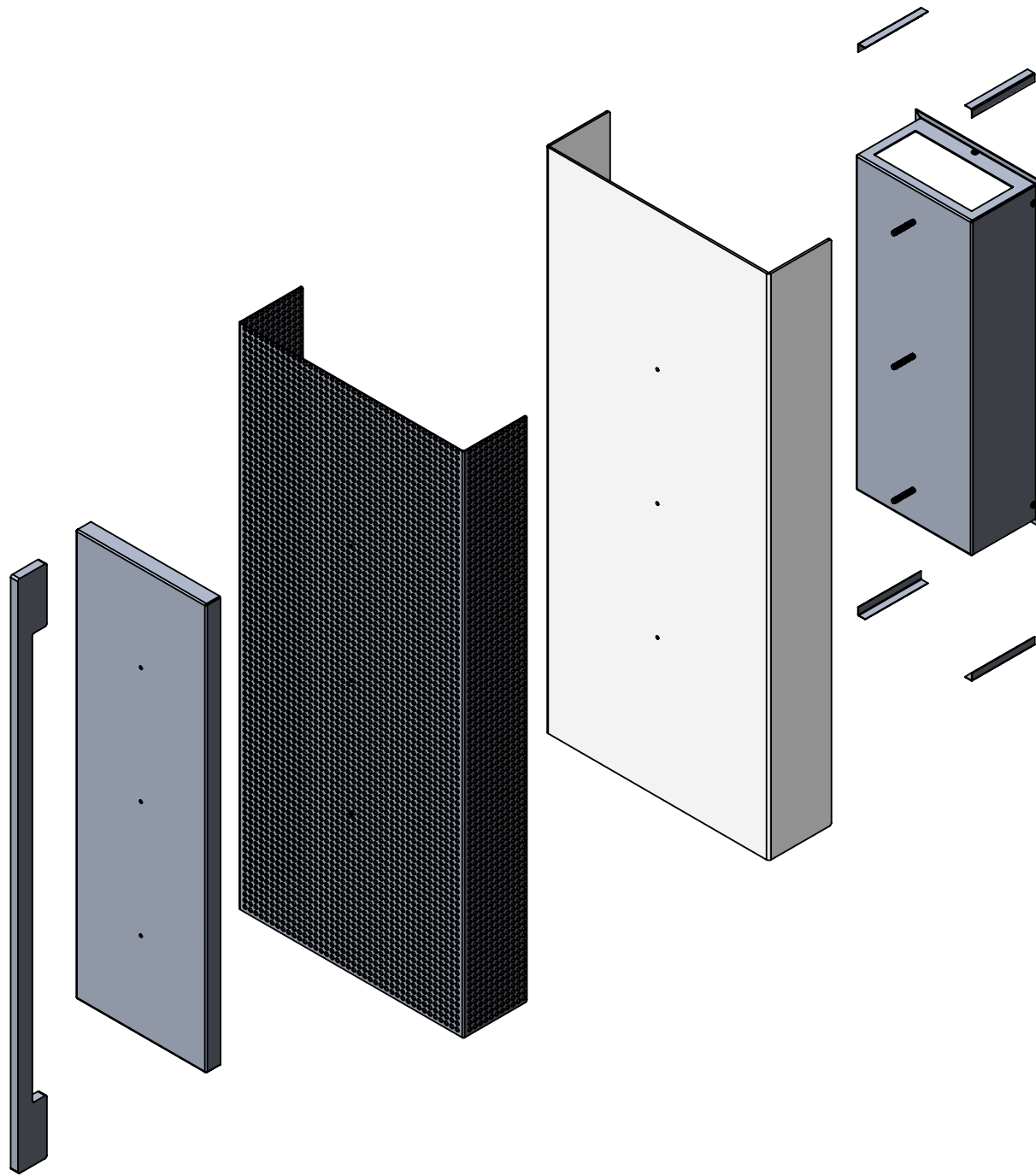

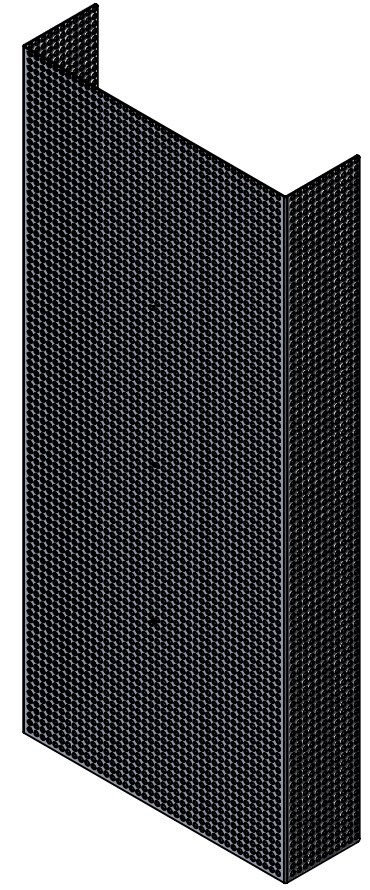
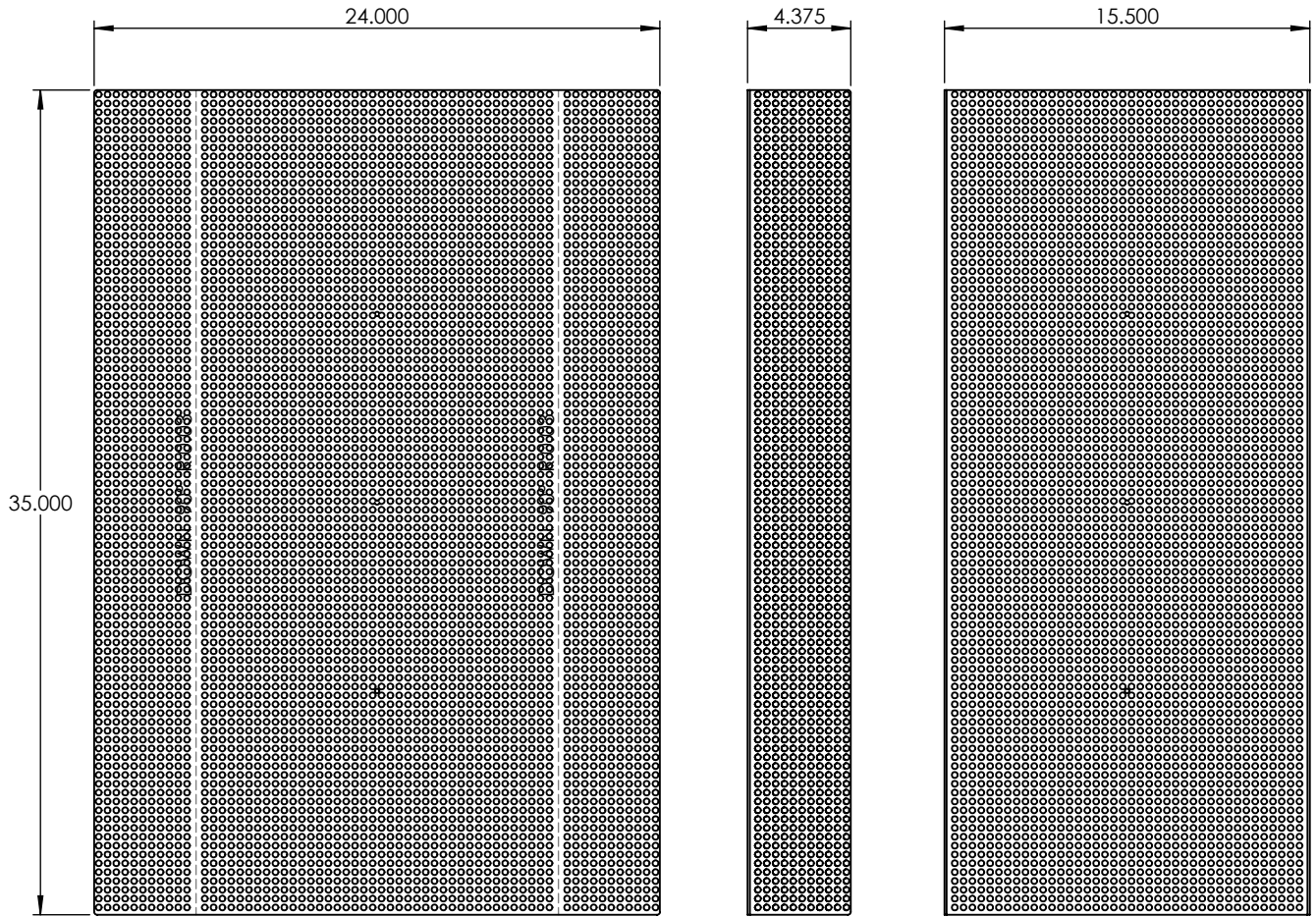

PROPRIETARY AND CONFIDENTIAL
 THE INFORMATION CONTAINED IN THIS DRAWING IS THE SOLE PROPERTY OF <INSERT COMPANY NAME HERE>. ANY REPRODUCTION IN PART OR AS A WHOLE WITHOUT THE WRITTEN PERMISSION OF <INSERT COMPANY NAME HERE> IS PROHIBITED.

		UNLESS OTHERWISE SPECIFIED:		NAME	DATE
		DIMENSIONS ARE IN INCHES TOLERANCES: FRACTIONAL ± ANGULAR: MACH ± BEND ± TWO PLACE DECIMAL ± THREE PLACE DECIMAL ±	DRAWN		
		INTERPRET GEOMETRIC TOLERANCING PER:	CHECKED		
		MATERIAL	ENG APPR.		
		FINISH	MFG APPR.		
			Q.A.		
			COMMENTS:		
NEXT ASSY	USED ON				
APPLICATION		DO NOT SCALE DRAWING			

ALUMINUM HOLE MESH		
TITLE:		
SHDPF-WL-20W-MN-WF-WET-30K		
SIZE	DWG. NO.	REV
A		
SCALE: 1:8	WEIGHT:	SHEET 4 OF 10

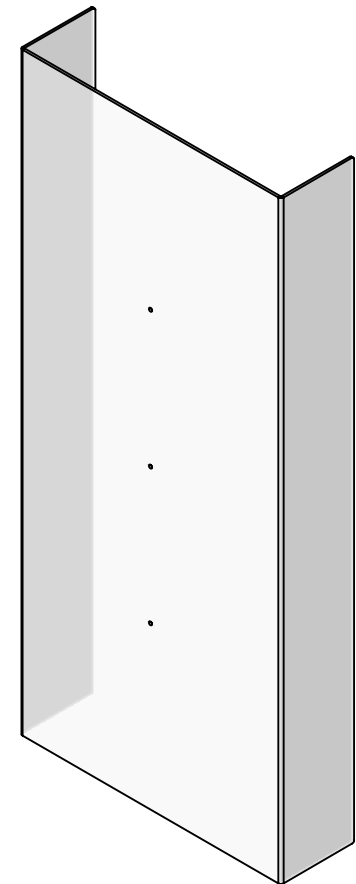
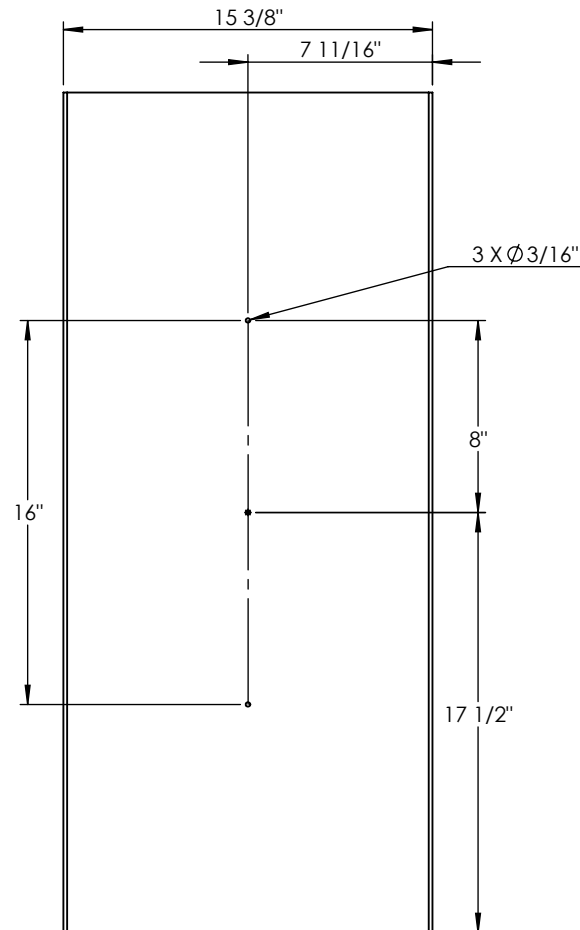
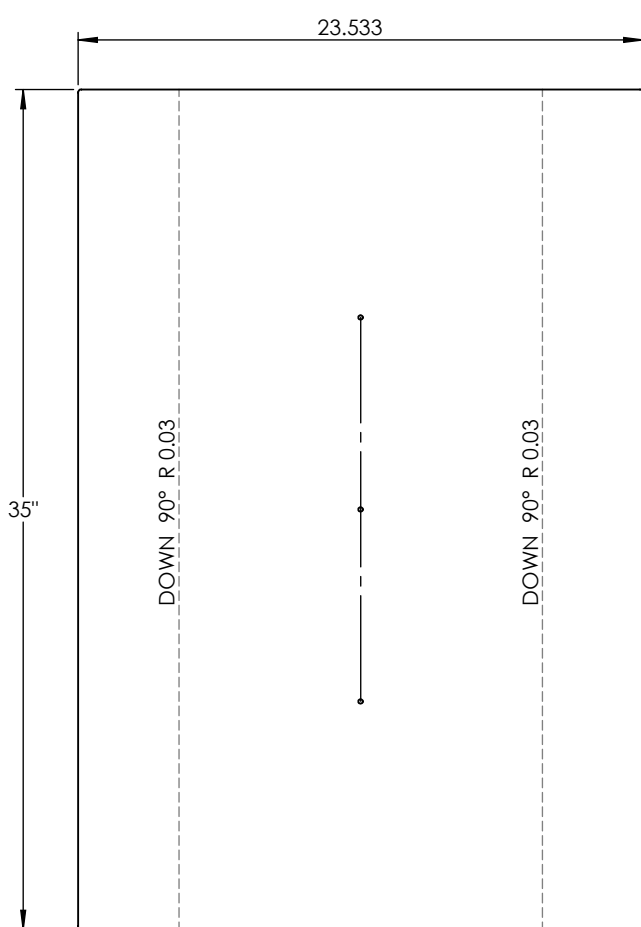

PROPRIETARY AND CONFIDENTIAL
 THE INFORMATION CONTAINED IN THIS DRAWING IS THE SOLE PROPERTY OF <INSERT COMPANY NAME HERE>. ANY REPRODUCTION IN PART OR AS A WHOLE WITHOUT THE WRITTEN PERMISSION OF <INSERT COMPANY NAME HERE> IS PROHIBITED.

		UNLESS OTHERWISE SPECIFIED:	NAME	DATE
		DIMENSIONS ARE IN INCHES TOLERANCES: FRACTIONAL ± ANGULAR: MACH ± BEND ± TWO PLACE DECIMAL ± THREE PLACE DECIMAL ±	DRAWN	
		INTERPRET GEOMETRIC TOLERANCING PER:	CHECKED	
	NEXT ASSY	MATERIAL	ENG APPR.	
	USED ON	FINISH	MFG APPR.	
APPLICATION		DO NOT SCALE DRAWING	Q.A.	
			COMMENTS:	

ACRYLIC

TITLE:
SHDPF-WL-20W-MN-WF-WET-30K

SIZE A	DWG. NO.	REV
SCALE: 1:8	WEIGHT:	SHEET 5 OF 10

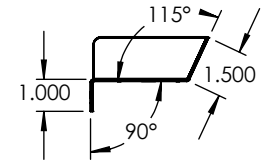
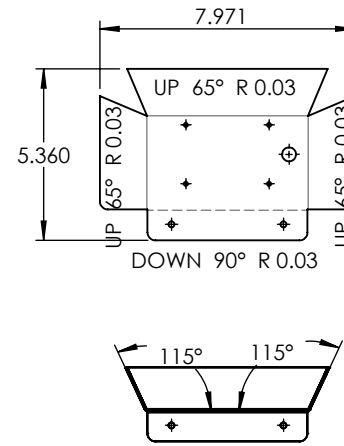
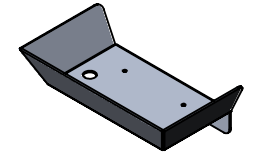
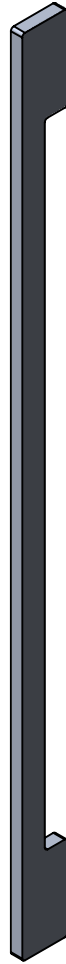
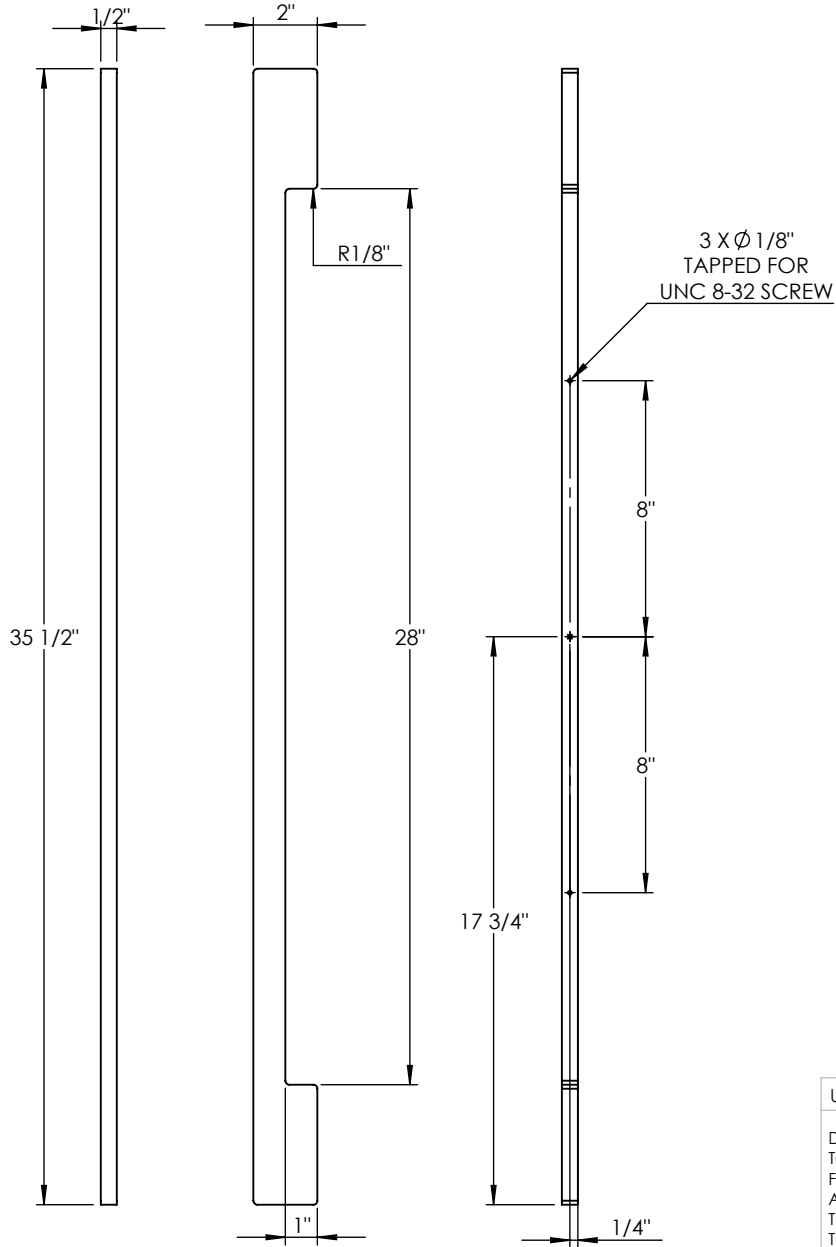

UNLESS OTHERWISE SPECIFIED:		NAME	DATE	1/2"X2" ALUMINUM PLATE	
DIMENSIONS ARE IN INCHES TOLERANCES: FRACTIONAL ± ANGULAR: MACH ± BEND ± TWO PLACE DECIMAL ± THREE PLACE DECIMAL ±		DRAWN			
INTERPRET GEOMETRIC TOLERANCING PER:		CHECKED		SHDPF-WL-20W-MN-WF-WET-30K	
MATERIAL		ENG APPR.		SIZE	DWG. NO.
FINISH		MFG APPR.		A	
NEXT ASSY		Q.A.		SCALE: 1:6	WEIGHT:
USED ON		COMMENTS:			SHEET 6 OF 10
APPLICATION					
DO NOT SCALE DRAWING					

PROPRIETARY AND CONFIDENTIAL
THE INFORMATION CONTAINED IN THIS DRAWING IS THE SOLE PROPERTY OF <INSERT COMPANY NAME HERE>. ANY REPRODUCTION IN PART OR AS A WHOLE WITHOUT THE WRITTEN PERMISSION OF <INSERT COMPANY NAME HERE> IS PROHIBITED.

5

4

3

2

1

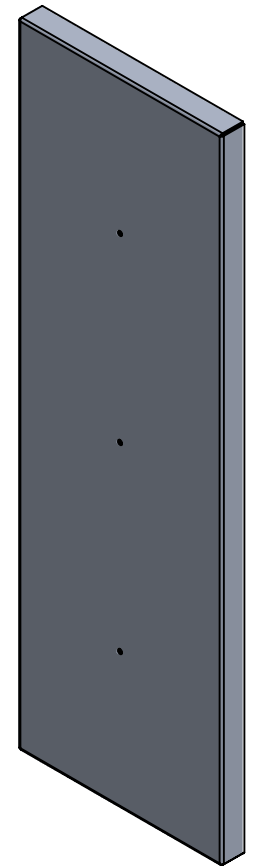
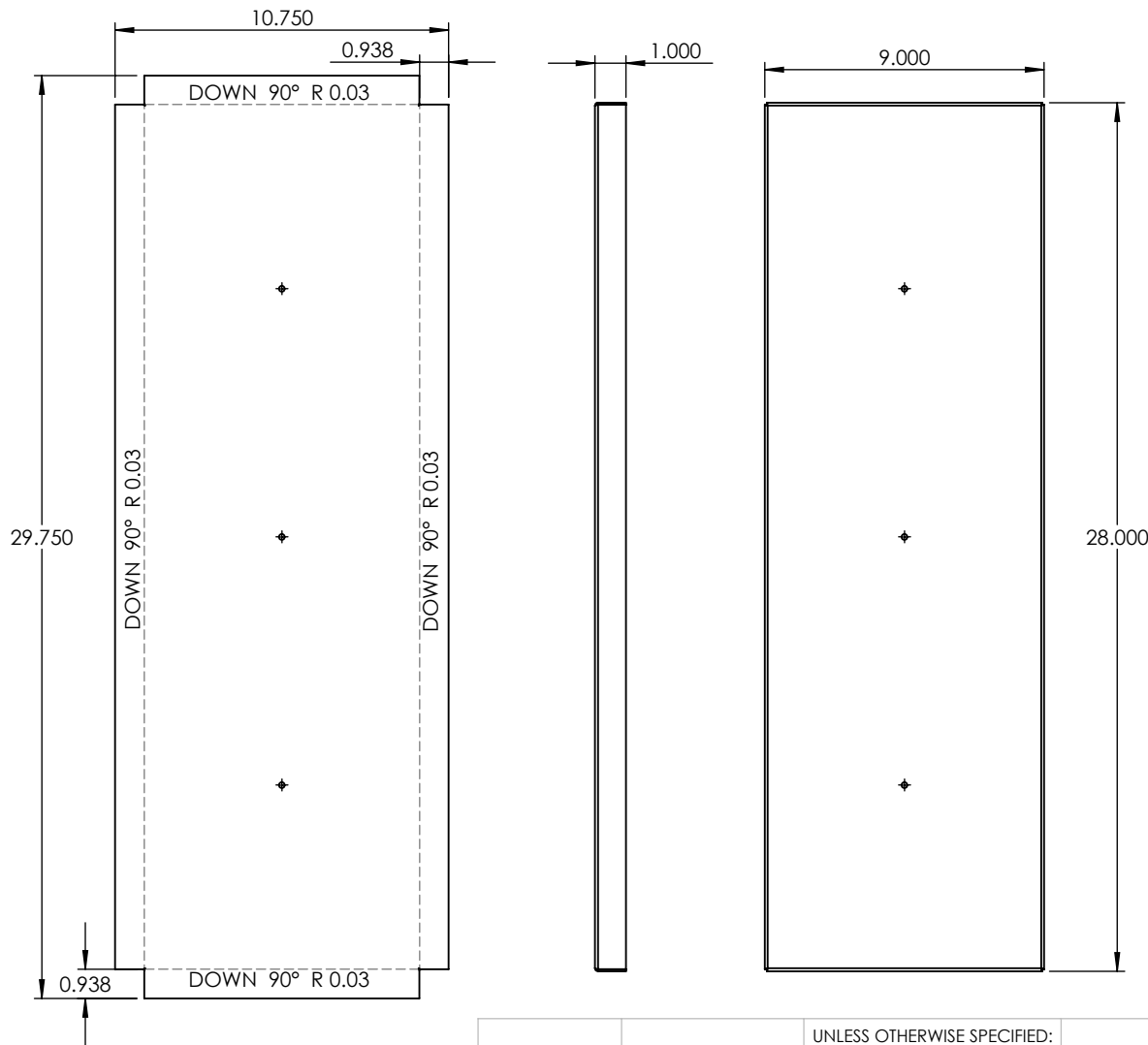

PROPRIETARY AND CONFIDENTIAL
 THE INFORMATION CONTAINED IN THIS DRAWING IS THE SOLE PROPERTY OF <INSERT COMPANY NAME HERE>. ANY REPRODUCTION IN PART OR AS A WHOLE WITHOUT THE WRITTEN PERMISSION OF <INSERT COMPANY NAME HERE> IS PROHIBITED.

		UNLESS OTHERWISE SPECIFIED:		NAME	DATE
		DIMENSIONS ARE IN INCHES	DRAWN		
		TOLERANCES:	CHECKED		
		FRACTIONAL ±	ENG APPR.		
		ANGULAR: MACH ± BEND ±	MFG APPR.		
		TWO PLACE DECIMAL ±	Q.A.		
		THREE PLACE DECIMAL ±	COMMENTS:		
		INTERPRET GEOMETRIC TOLERANCING PER:			
		MATERIAL			
		FINISH			
NEXT ASSY	USED ON				
APPLICATION	DO NOT SCALE DRAWING				

ALUMINUM 0.0635"		
TITLE:		
SHDPF-WL-20W-MN-WF-WET-30K		
SIZE	DWG. NO.	REV
A		
SCALE: 1:6	WEIGHT:	SHEET 7 OF 10

5

4

3

2

1

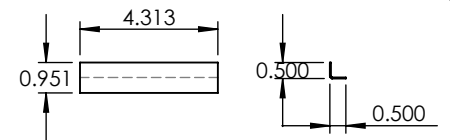
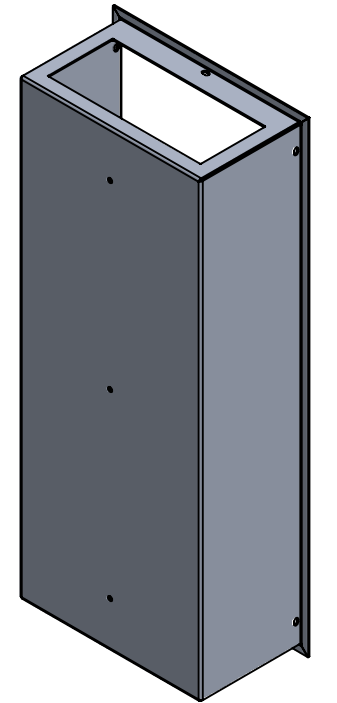
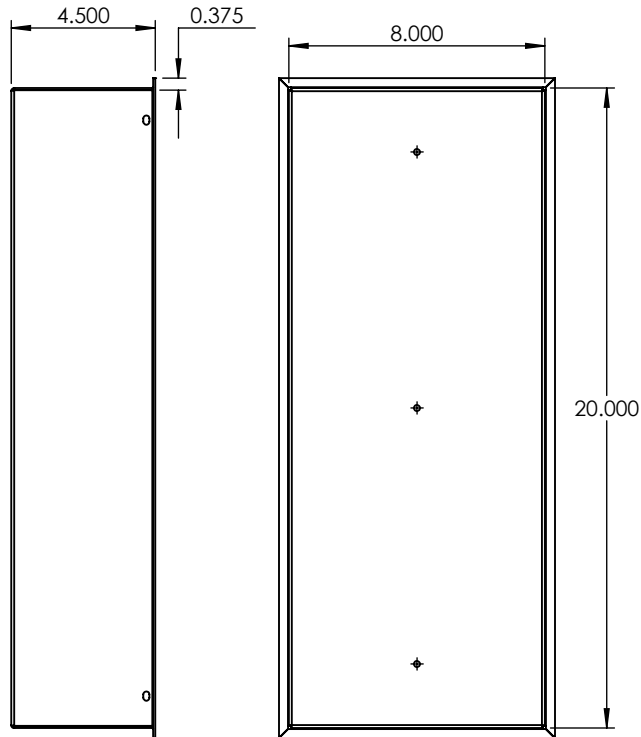
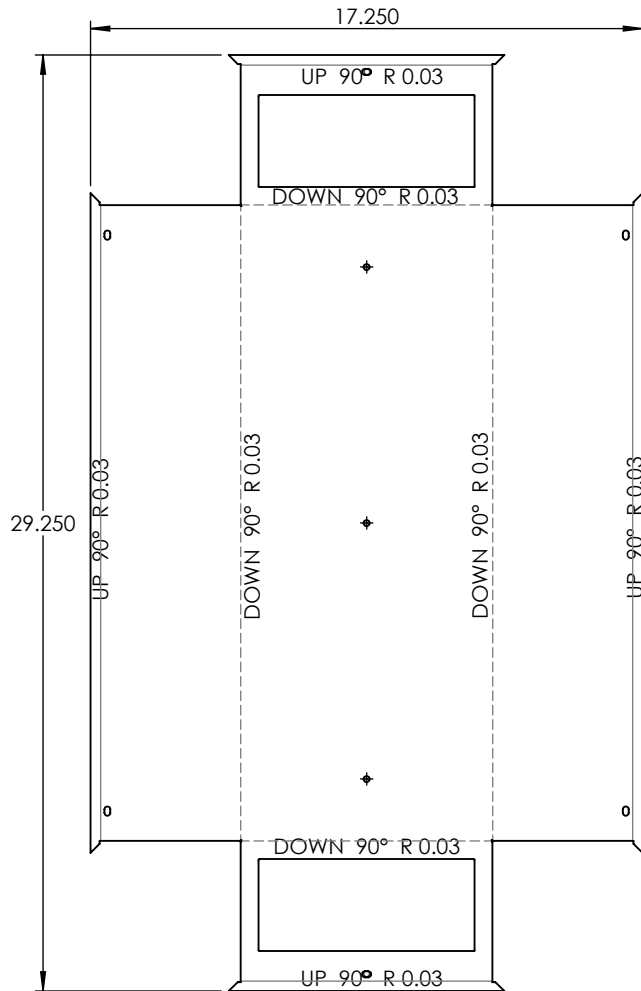

UNLESS OTHERWISE SPECIFIED:

DIMENSIONS ARE IN INCHES
 TOLERANCES:
 FRACTIONAL ±
 ANGULAR: MACH ± BEND ±
 TWO PLACE DECIMAL ±
 THREE PLACE DECIMAL ±

INTERPRET GEOMETRIC
 TOLERANCING PER:

MATERIAL

FINISH

NAME

DATE

DRAWN

CHECKED

ENG APPR.

MFG APPR.

Q.A.

COMMENTS:

ALUMINUM 0.0635"

TITLE:

SHDPF-WL-20W-MN-WF-WET-30K

SIZE
A

DWG. NO.

REV

SCALE: 1:6

WEIGHT:

SHEET 8 OF 10

PROPRIETARY AND CONFIDENTIAL
 THE INFORMATION CONTAINED IN THIS
 DRAWING IS THE SOLE PROPERTY OF
 <INSERT COMPANY NAME HERE>. ANY
 REPRODUCTION IN PART OR AS A WHOLE
 WITHOUT THE WRITTEN PERMISSION OF
 <INSERT COMPANY NAME HERE> IS
 PROHIBITED.

NEXT ASSY

USED ON

APPLICATION

DO NOT SCALE DRAWING

5

4

3

2

1

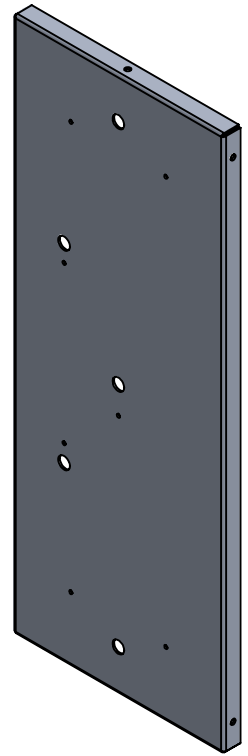
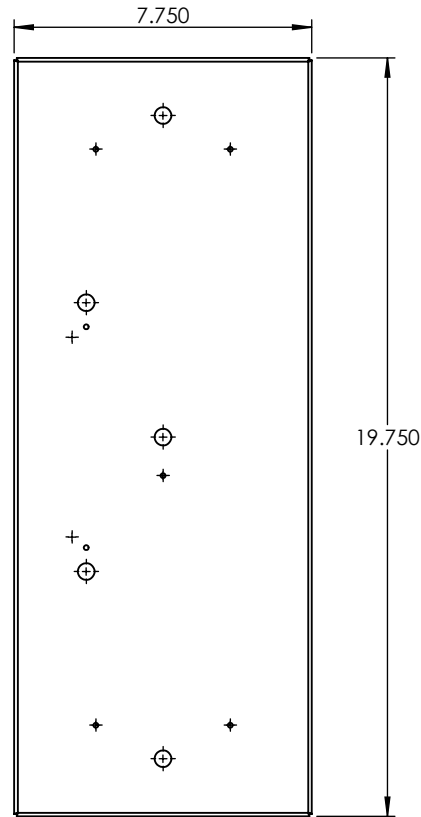
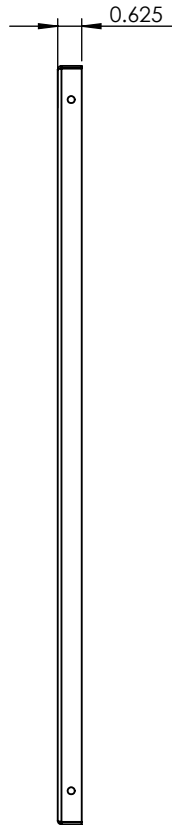
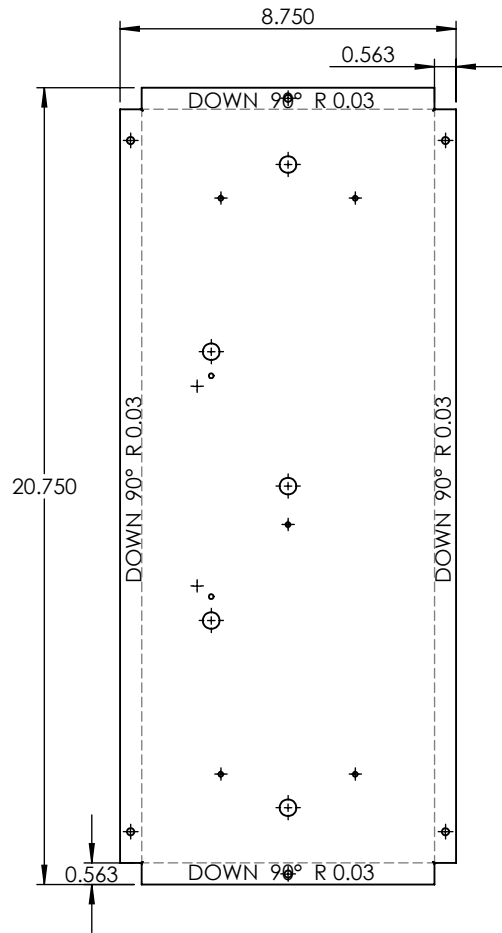

PROPRIETARY AND CONFIDENTIAL
 THE INFORMATION CONTAINED IN THIS DRAWING IS THE SOLE PROPERTY OF <INSERT COMPANY NAME HERE>. ANY REPRODUCTION IN PART OR AS A WHOLE WITHOUT THE WRITTEN PERMISSION OF <INSERT COMPANY NAME HERE> IS PROHIBITED.

		UNLESS OTHERWISE SPECIFIED:		NAME	DATE
		DIMENSIONS ARE IN INCHES	DRAWN		
		TOLERANCES:	CHECKED		
		FRACTIONAL ±	ENG APPR.		
		ANGULAR: MACH ± BEND ±	MFG APPR.		
		TWO PLACE DECIMAL ±	Q.A.		
		THREE PLACE DECIMAL ±	COMMENTS:		
		INTERPRET GEOMETRIC TOLERANCING PER:			
		MATERIAL			
	NEXT ASSY	FINISH			
	USED ON				
	APPLICATION	DO NOT SCALE DRAWING			

ALUMINUM 0.0635"		
TITLE:		
SHDPF-WL-20W-MN-WF-WET-30K		
SIZE	DWG. NO.	REV
A		
SCALE: 1:5	WEIGHT:	SHEET 9 OF 10

5

4

3

2

1

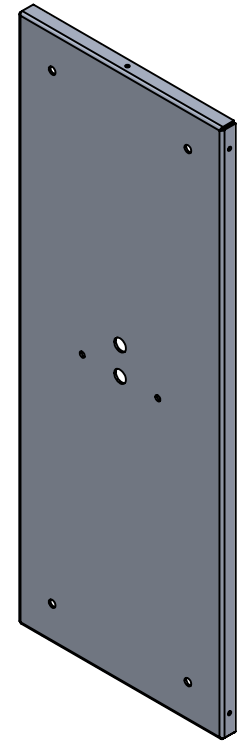
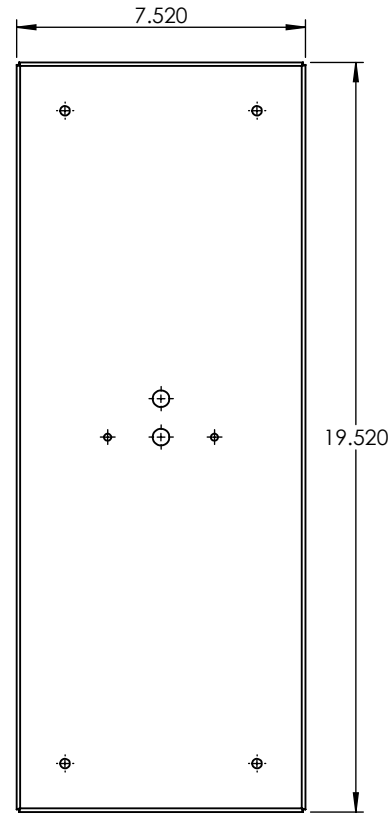
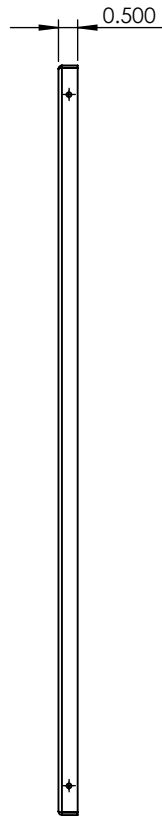
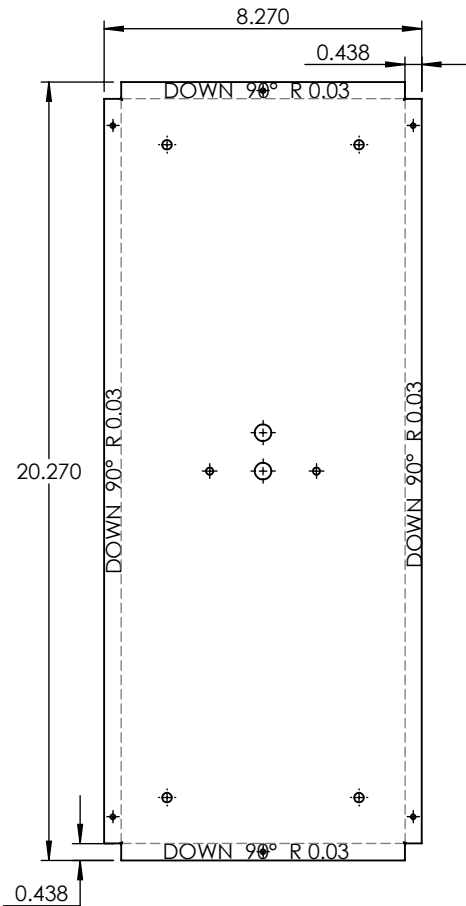

PROPRIETARY AND CONFIDENTIAL
 THE INFORMATION CONTAINED IN THIS DRAWING IS THE SOLE PROPERTY OF <INSERT COMPANY NAME HERE>. ANY REPRODUCTION IN PART OR AS A WHOLE WITHOUT THE WRITTEN PERMISSION OF <INSERT COMPANY NAME HERE> IS PROHIBITED.

		UNLESS OTHERWISE SPECIFIED:		NAME	DATE
		DIMENSIONS ARE IN INCHES	DRAWN		
		TOLERANCES:	CHECKED		
		FRACTIONAL ±	ENG APPR.		
		ANGULAR: MACH ± BEND ±	MFG APPR.		
		TWO PLACE DECIMAL ±	Q.A.		
		THREE PLACE DECIMAL ±	COMMENTS:		
		INTERPRET GEOMETRIC TOLERANCING PER:			
		MATERIAL			
NEXT ASSY	USED ON	FINISH			
APPLICATION		DO NOT SCALE DRAWING			

ALUMINUM 0.0635"		
TITLE:		
SHDPF-WL-20W-MN-WF-WET-30K		
SIZE	DWG. NO.	REV
A		
SCALE: 1:5	WEIGHT:	SHEET 10 OF 10

5

4

3

2

1