

ITEM NO.	PART NUMBER	DESCRIPTION	QTY.	CUT
1	SHD-DRM-P3AC30-DIM-AB-WF-32"OAH-30K-SPUN CANOPY	SPUN ALUMINUM 0.080"	1	
2	SHD-DRM-P3AC30-DIM-AB-WF-32"OAH-30K-SUPPORT FIREPLATE	SPUN ALUMINUM .080"	1	
3	SHD-DRM-P3AC30-DIM-AB-WF-32"OAH-30K-TOP ROUND COVER	ALUMINUM 0.0635"	1	
4	SHD-DRM-P3AC30-DIM-AB-WF-32"OAH-30K-SUPPORT BRACKET	ALUMINUM 0.635"	6	
5	SHD-DRM-P3AC30-DIM-AB-WF-32"OAH-30K-WIRE FRAME	1/2" ROUND ALUMINUM BAR	1	
6	SHD-DRM-P3AC30-DIM-AB-WF-32"OAH-30K-WIRE	AIRCRAFT WIRE	1	
7	SHD-DRM-P3AC30-DIM-AB-WF-32"OAH-30K-ACRYLIC DRUM	ACRYLIC	1	
8	BALL THUMBSCREW	THUMBSCREW	4	
9	KTLD-25-UV-700-VDIM-LA1	DRIVER	2	
10	Altailed PN105B-11-SS	LED	8	

UNLESS OTHERWISE SPECIFIED:

DIMENSIONS ARE IN INCHES
 TOLERANCES:
 FRACTIONAL ± .003
 ANGULAR: MACH ± .01 BEND ±
 TWO PLACE DECIMAL ±
 THREE PLACE DECIMAL ±.001

INTERPRET GEOMETRIC
 TOLERANCING PER:
 MATERIAL

FINISH

	NAME	DATE
DRAWN		
CHECKED		
ENG APPR.		
MFG APPR.		
Q.A.		

COMMENTS:

TITLE:

SHD-DRM-P3AC30-DIM-AB-WF-32"OAH-3

SIZE DWG. NO. REV

A TICKET 25807

SCALE: 1:14 WEIGHT: SHEET 1 OF 7

EVERGREEN LIGHTING

ALL BEND RADIUS .030"

APPLICATION

DO NOT SCALE DRAWING

5

4

3

2

1

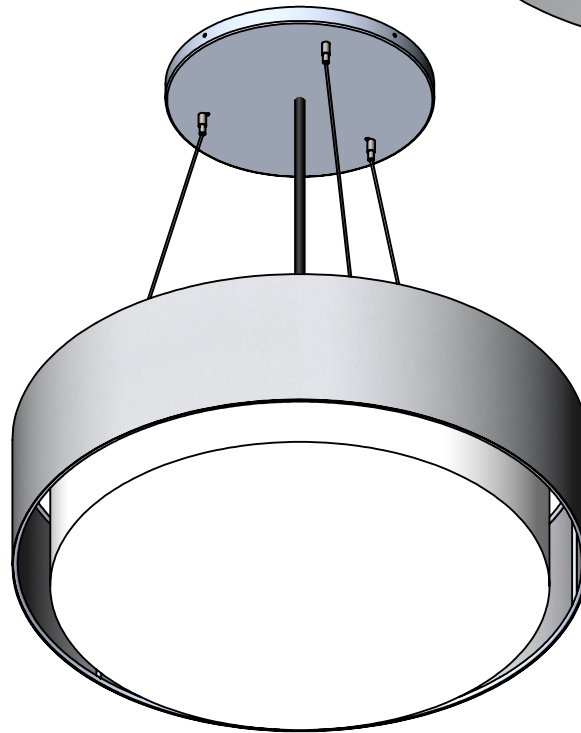
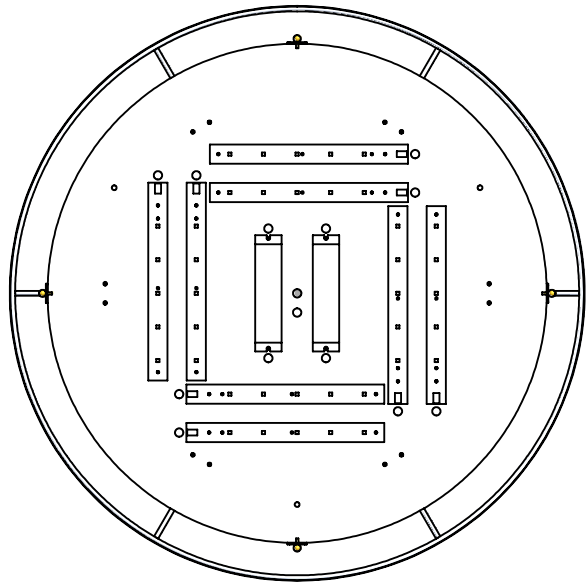
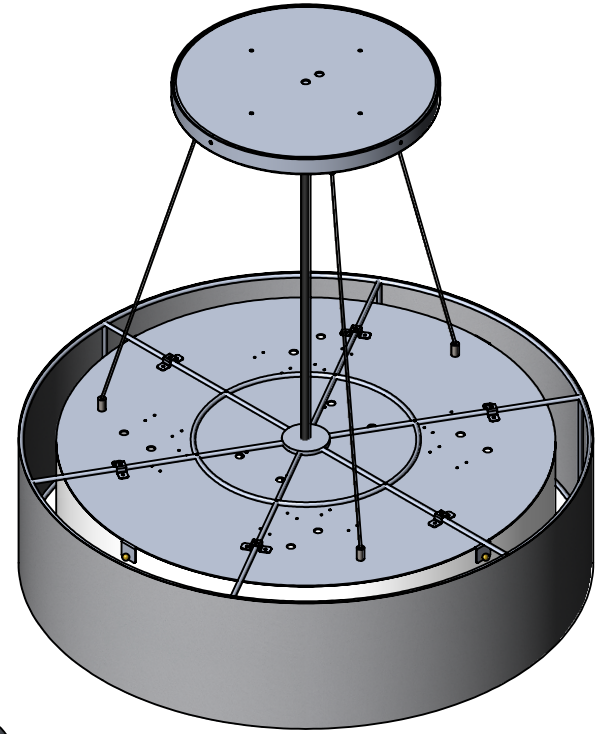
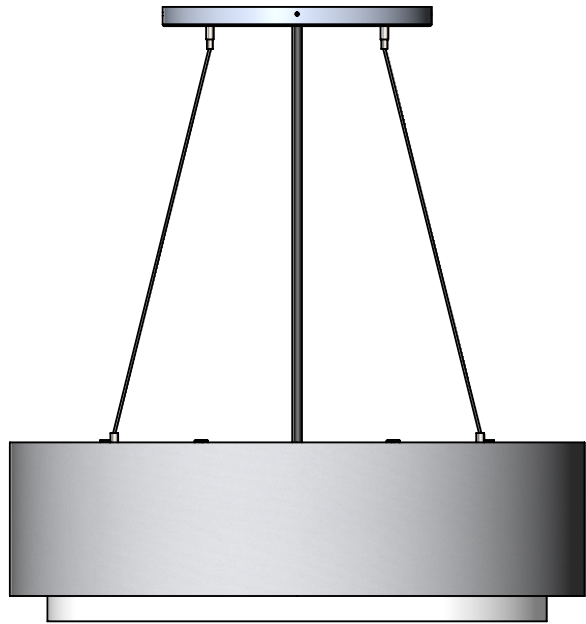

ITEM NO.	PART NUMBER	DESCRIPTION	QTY.
1	SHD-DRM-P3AC30-DIM-AB-WF-32"OAH-30K-SPUN CANOPY	SPUN ALUMINUM 0.080"	1

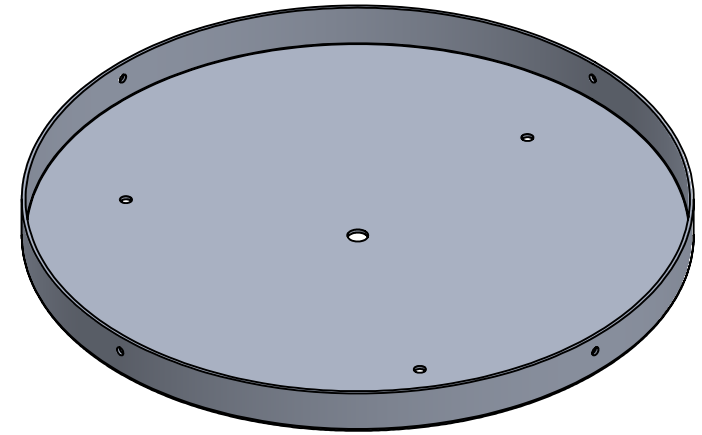
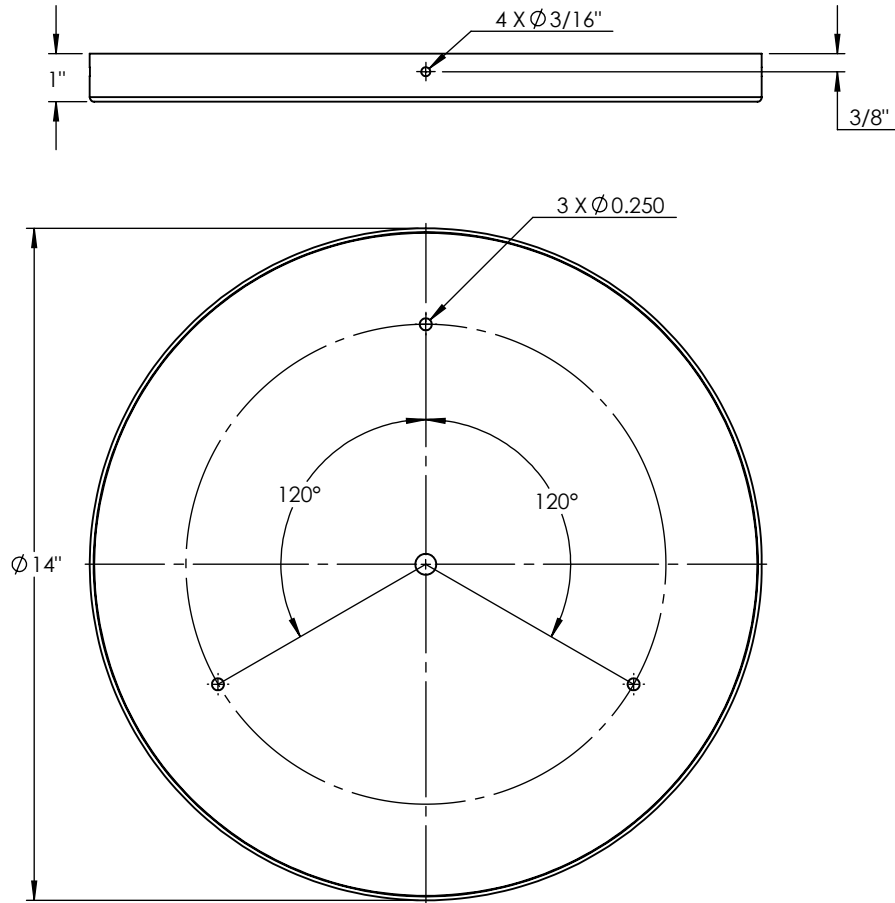

PROPRIETARY AND CONFIDENTIAL
 THE INFORMATION CONTAINED IN THIS DRAWING IS THE SOLE PROPERTY OF <INSERT COMPANY NAME HERE>. ANY REPRODUCTION IN PART OR AS A WHOLE WITHOUT THE WRITTEN PERMISSION OF <INSERT COMPANY NAME HERE> IS PROHIBITED.

		UNLESS OTHERWISE SPECIFIED:	NAME	DATE	SPUN ALUMINUM 0.080"	
		DIMENSIONS ARE IN INCHES	DRAWN		TITLE:	
		TOLERANCES:	CHECKED		SHD-DRM-P3AC30-DIM-AB-WF-32"OAH-30K	
		FRACTIONAL ±	ENG APPR.		SIZE	DWG. NO.
		ANGULAR: MACH ± BEND ±	MFG APPR.		A	REV
		TWO PLACE DECIMAL ±	Q.A.		SCALE: 1:4	WEIGHT:
		THREE PLACE DECIMAL ±	COMMENTS:			SHEET 3 OF 7
NEXT ASSY	USED ON	INTERPRET GEOMETRIC TOLERANCING PER:				
		MATERIAL				
		FINISH				
APPLICATION		DO NOT SCALE DRAWING				

5

4

3

2

1

ITEM NO.	PART NUMBER	DESCRIPTION	QTY.
1	SHD-DRM-P3AC30-DIM-AB-WF-32"OAH-30K-SUPPORT FIREPLATE	SPUN ALUMINUM .080"	1

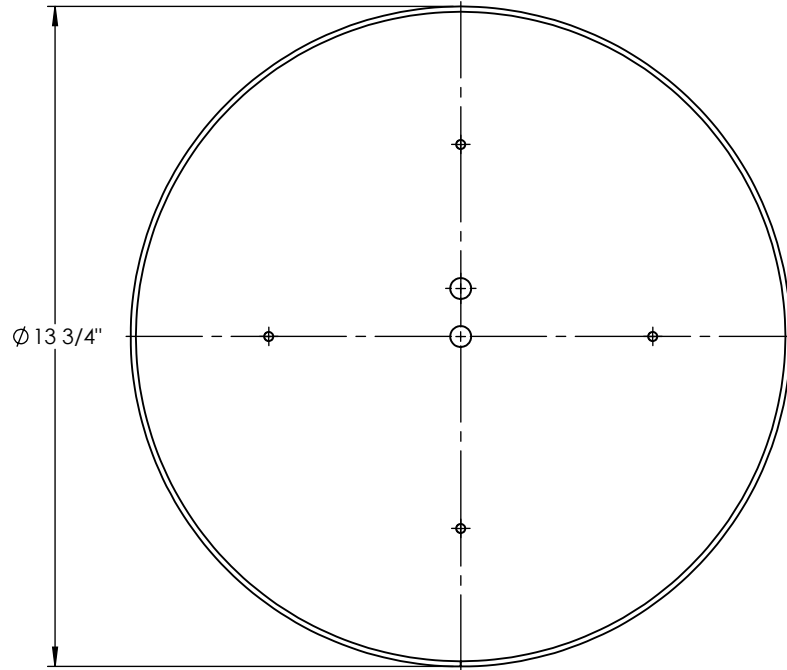
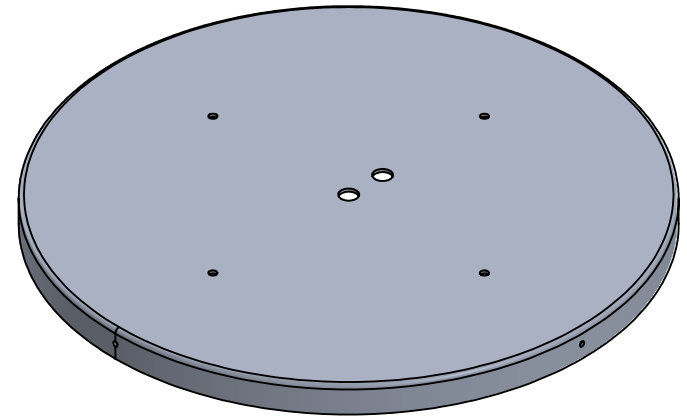
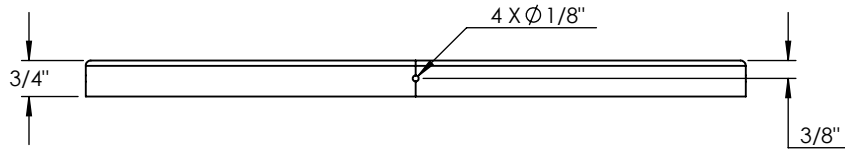

PROPRIETARY AND CONFIDENTIAL
 THE INFORMATION CONTAINED IN THIS DRAWING IS THE SOLE PROPERTY OF <INSERT COMPANY NAME HERE>. ANY REPRODUCTION IN PART OR AS A WHOLE WITHOUT THE WRITTEN PERMISSION OF <INSERT COMPANY NAME HERE> IS PROHIBITED.

		UNLESS OTHERWISE SPECIFIED:	NAME	DATE
		DIMENSIONS ARE IN INCHES TOLERANCES: FRACTIONAL ± ANGULAR: MACH ± BEND ± TWO PLACE DECIMAL ± THREE PLACE DECIMAL ±	DRAWN	
		INTERPRET GEOMETRIC TOLERANCING PER:	CHECKED	
		MATERIAL	ENG APPR.	
		FINISH	MFG APPR.	
NEXT ASSY	USED ON		Q.A.	
APPLICATION		DO NOT SCALE DRAWING	COMMENTS:	

SPUN ALUMINUM .080"		
TITLE:		
SHD-DRM-P3AC30-DIM-AB-WF-32"OAH-30K		
SIZE	DWG. NO.	REV
A		
SCALE: 1:4	WEIGHT:	SHEET 4 OF 7

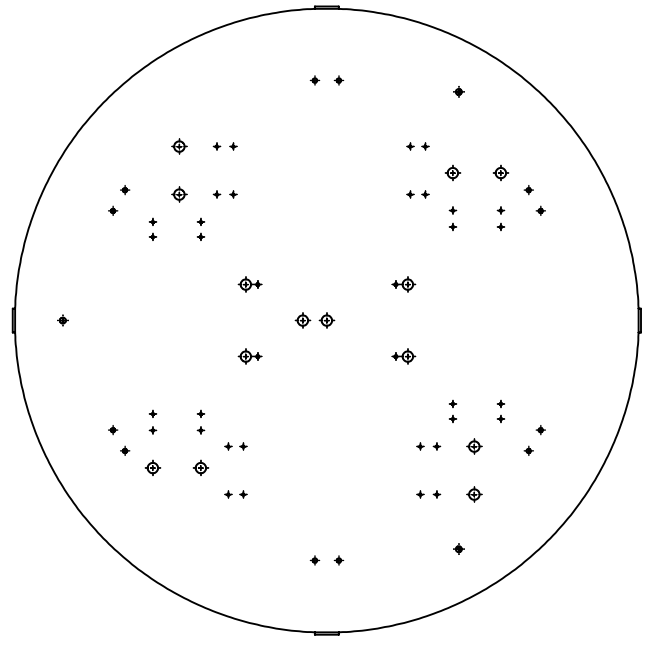
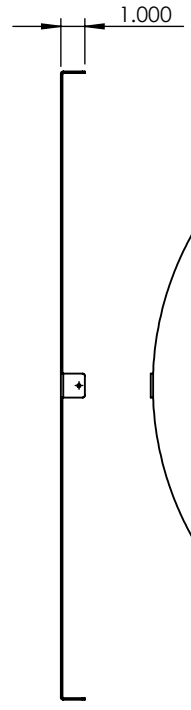
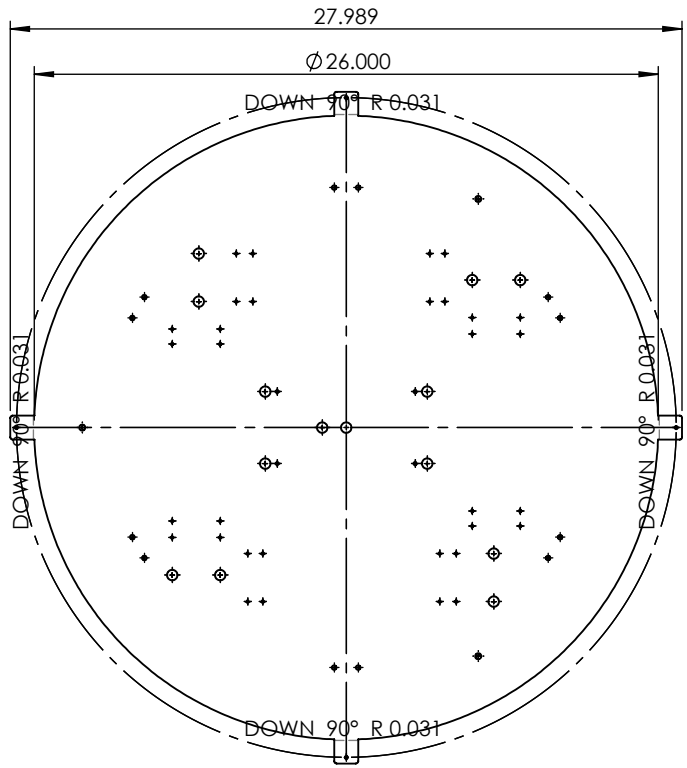
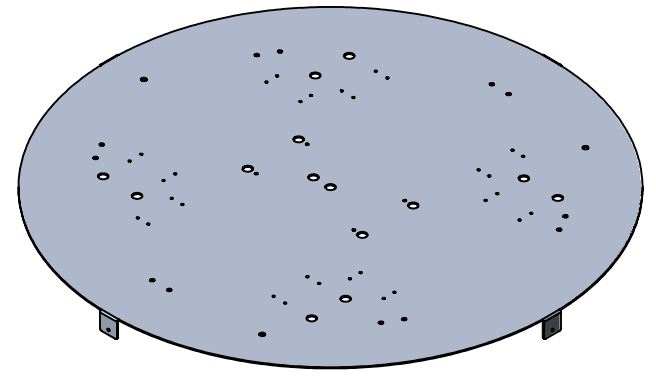

PROPRIETARY AND CONFIDENTIAL
 THE INFORMATION CONTAINED IN THIS DRAWING IS THE SOLE PROPERTY OF <INSERT COMPANY NAME HERE>. ANY REPRODUCTION IN PART OR AS A WHOLE WITHOUT THE WRITTEN PERMISSION OF <INSERT COMPANY NAME HERE> IS PROHIBITED.

		UNLESS OTHERWISE SPECIFIED:		NAME	DATE
		DIMENSIONS ARE IN INCHES	DRAWN		
		TOLERANCES:	CHECKED		
		FRACTIONAL ±	ENG APPR.		
		ANGULAR: MACH ± BEND ±	MFG APPR.		
		TWO PLACE DECIMAL ±	Q.A.		
		THREE PLACE DECIMAL ±	COMMENTS:		
		INTERPRET GEOMETRIC TOLERANCING PER:			
		MATERIAL			
NEXT ASSY	USED ON	FINISH			
APPLICATION		DO NOT SCALE DRAWING			

ALUMINUM 0.0635"		
TITLE:		
SHD-DRM-P3AC30-DIM-AB-WF-32"OAH-30K		
SIZE	DWG. NO.	REV
A		
SCALE: 1:8	WEIGHT:	SHEET 5 OF 7

5

4

3

2

1

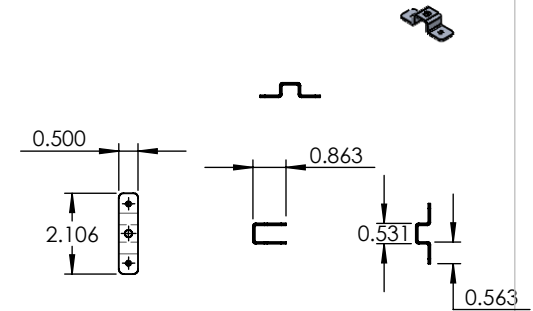
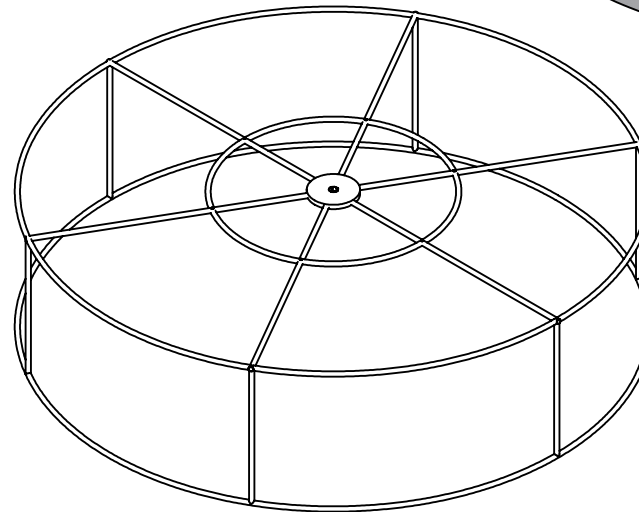
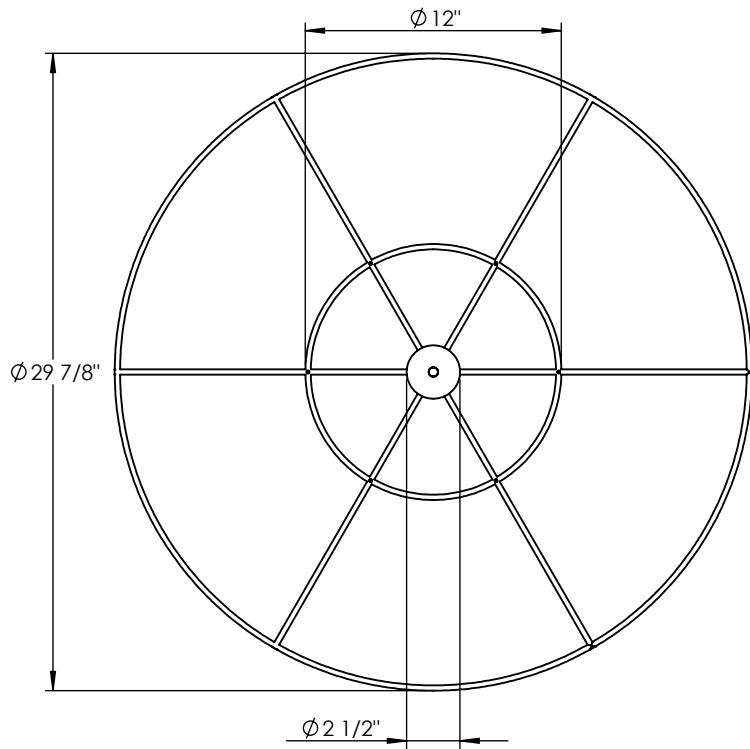
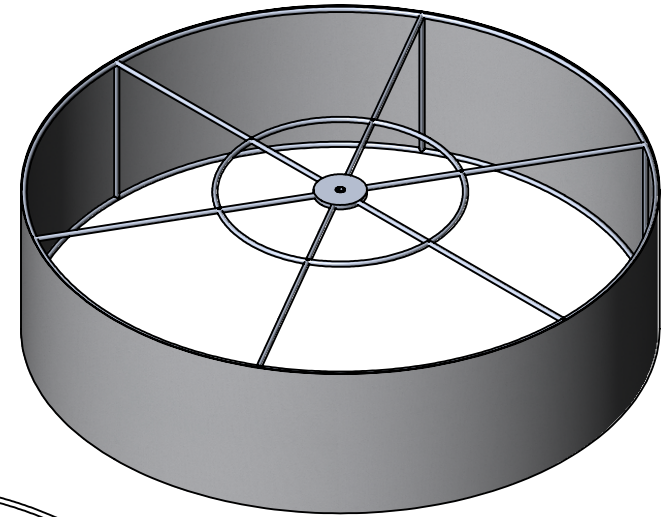
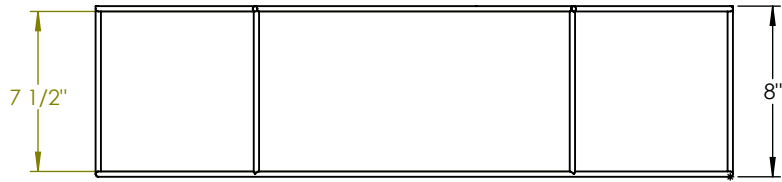

PROPRIETARY AND CONFIDENTIAL
 THE INFORMATION CONTAINED IN THIS DRAWING IS THE SOLE PROPERTY OF <INSERT COMPANY NAME HERE>. ANY REPRODUCTION IN PART OR AS A WHOLE WITHOUT THE WRITTEN PERMISSION OF <INSERT COMPANY NAME HERE> IS PROHIBITED.

		UNLESS OTHERWISE SPECIFIED:		NAME	DATE
		DIMENSIONS ARE IN INCHES	DRAWN		
		TOLERANCES:	CHECKED		
		FRACTIONAL ±	ENG APPR.		
		ANGULAR: MACH ± BEND ±	MFG APPR.		
		TWO PLACE DECIMAL ±	Q.A.		
		THREE PLACE DECIMAL ±	COMMENTS:		
		INTERPRET GEOMETRIC TOLERANCING PER:			
		MATERIAL			
		FINISH			
NEXT ASSY	USED ON				
APPLICATION		DO NOT SCALE DRAWING			

1/2" ROUND ALUMINUM BAR

TITLE:

SHD-DRM-P3AC30-DIM-AB-WF-32"OAH-30K

SIZE	DWG. NO.	REV
A		

SCALE: 1:9	WEIGHT:	SHEET 6 OF 7
------------	---------	--------------

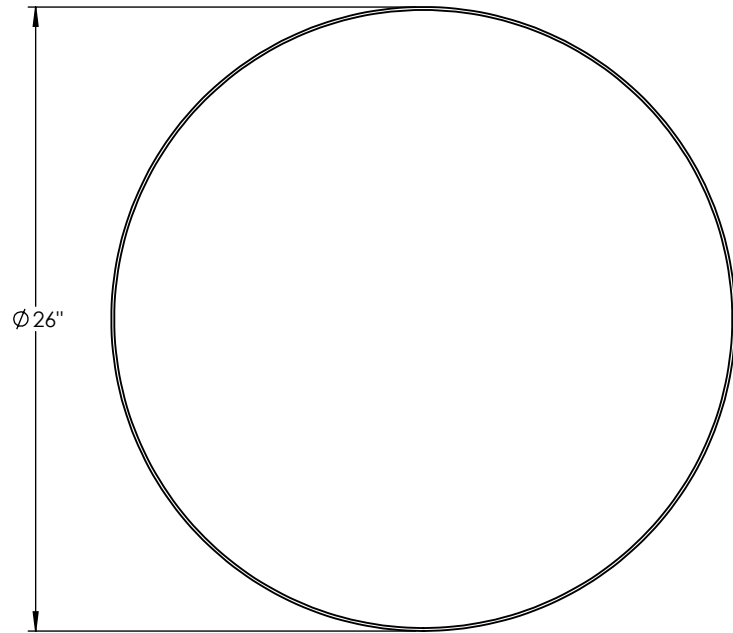
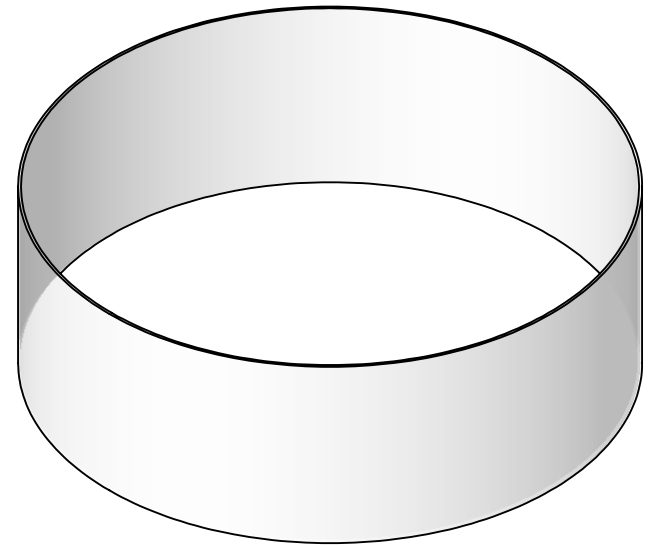
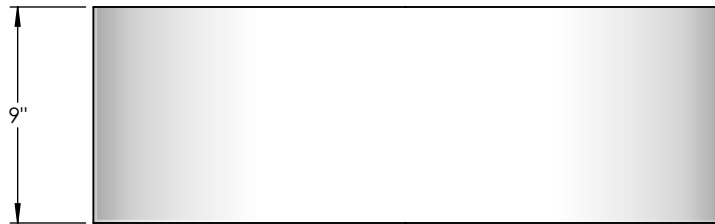

PROPRIETARY AND CONFIDENTIAL
 THE INFORMATION CONTAINED IN THIS DRAWING IS THE SOLE PROPERTY OF <INSERT COMPANY NAME HERE>. ANY REPRODUCTION IN PART OR AS A WHOLE WITHOUT THE WRITTEN PERMISSION OF <INSERT COMPANY NAME HERE> IS PROHIBITED.

		UNLESS OTHERWISE SPECIFIED:		NAME	DATE	ACRYLIC		
		DIMENSIONS ARE IN INCHES TOLERANCES: FRACTIONAL ± ANGULAR: MACH ± BEND ± TWO PLACE DECIMAL ± THREE PLACE DECIMAL ±	DRAWN					TITLE:
		INTERPRET GEOMETRIC TOLERANCING PER:	CHECKED			SHD-DRM-P3AC30-DIM-AB-WF-32"OAH-30K		
		MATERIAL	ENG APPR.			SIZE	DWG. NO.	REV
		FINISH	MFG APPR.			A		
NEXT ASSY	USED ON		Q.A.				SCALE: 1:8	WEIGHT:
APPLICATION		DO NOT SCALE DRAWING	COMMENTS:					

5

4

3

2

1