

ITEM NO.	PART NUMBER	DESCRIPTION	QTY.	CUT
1	CYL-VBB-FGR-20W-MN-WF-DIM-25"-30K-SPUN CUP	SPUN 22 GAUGE	2	
2	CYL-VBB-FGR-20W-MN-WF-DIM-25"-30K-BACKPLATE	22 GAUGE	1	
3	CYL-VBB-FGR-20W-MN-WF-DIM-25"-30K-BACKPLATE TAB	22 GAUGE	4	
4	CYL-VBB-FGR-20W-MN-WF-DIM-25"-30K-DRIVER BRACKET	22 GAUGE	1	
5	CYL-VBB-FGR-20W-MN-WF-DIM-25"-30K-FIREPLATE	22 GAUGE	1	
6	CYL-VBB-FGR-20W-MN-WF-DIM-25"-30K-LENS OUTERPLATE	22 GAUGE	1	
7	CYL-VBB-FGR-20W-MN-WF-DIM-25"-30K-LED BRACKET	22 GAUGE	1	
8	CYL-VBB-FGR-20W-MN-WF-DIM-25"-30K-OUTERPLATE COVER	22 GAUGE	1	
9	CYL-VBB-FGR-20W-MN-WF-DIM-25"-30K-LENS INNERPLATE	22 GAUGE	1	
10	CYL-VBB-FGR-20W-MN-WF-DIM-25"-30K-ACRYLIC	ACRYLIC	1	
11	CYL-VBB-FGR-20W-MN-WF-DIM-25"-30K-FLAT BAR	1/4" X 3/4" FLAT ALUMINUM BAR	2	
12	DS-15W-350C1542010-3001	DRIVER	2	
13	AltLED_PN110B_RevC	LED	2	

NEED SMALLER DRIVER TO FIT IN SHORT BACKPLATE

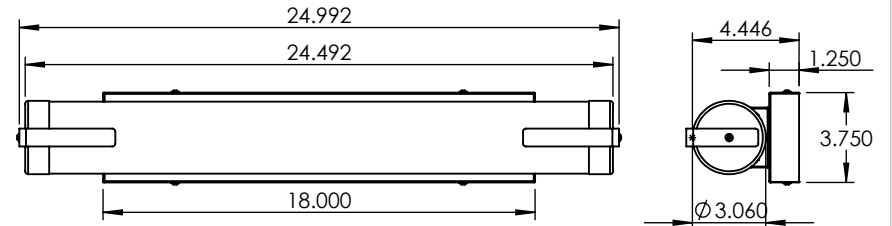
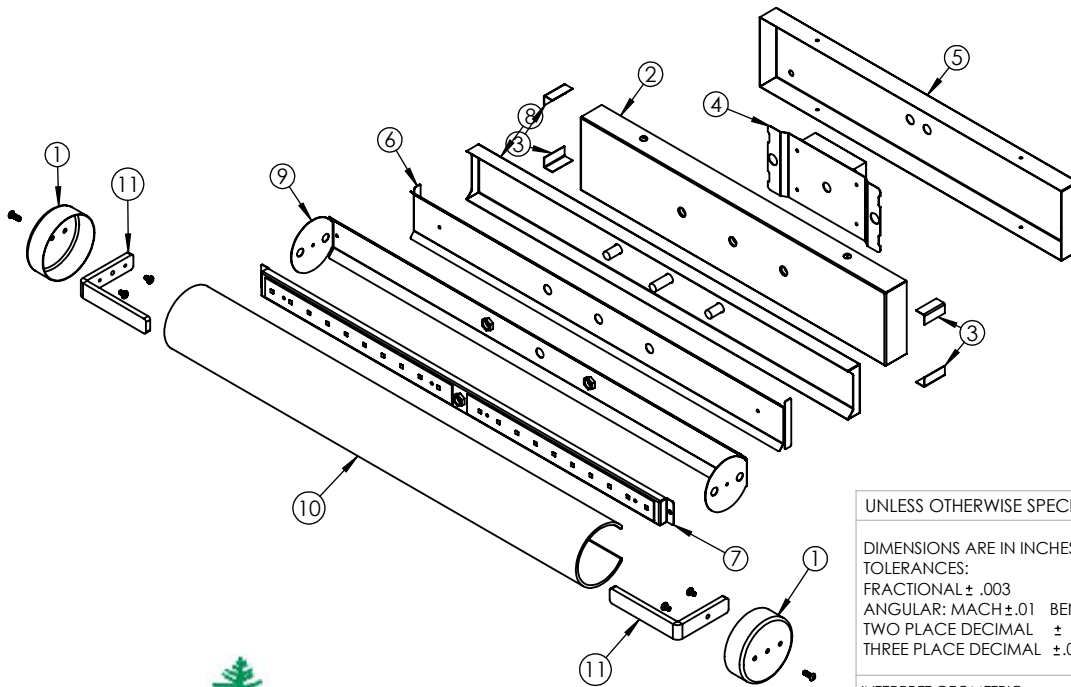
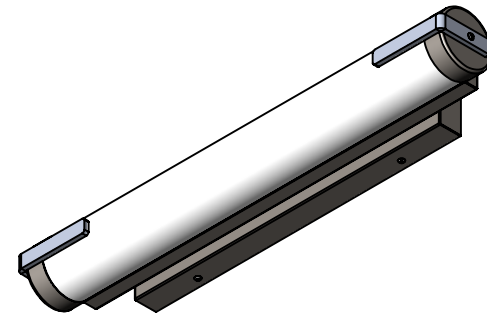
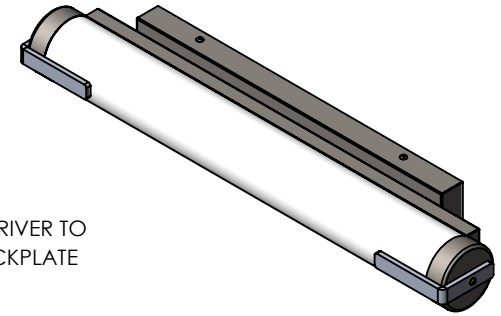

UNLESS OTHERWISE SPECIFIED:

DIMENSIONS ARE IN INCHES  
 TOLERANCES:  
 FRACTIONAL ± .003  
 ANGULAR: MACH ± .01 BEND ±  
 TWO PLACE DECIMAL ±  
 THREE PLACE DECIMAL ± .001

INTERPRET GEOMETRIC  
 TOLERANCING PER:  
 MATERIAL

FINISH

	NAME	DATE
DRAWN		
CHECKED		
ENG APPR.		
MFG APPR.		
Q.A.		

COMMENTS:

TITLE:

CYL-VBB-FGR-20W-MN-WF-DIM-25"-30K

SIZE DWG. NO. REV  
**A** TICKET 25807

SCALE: 1:8 WEIGHT: SHEET 1 OF 11



ALL BEND RADIUS .030"

APPLICATION

DO NOT SCALE DRAWING

5

4

3

2

1

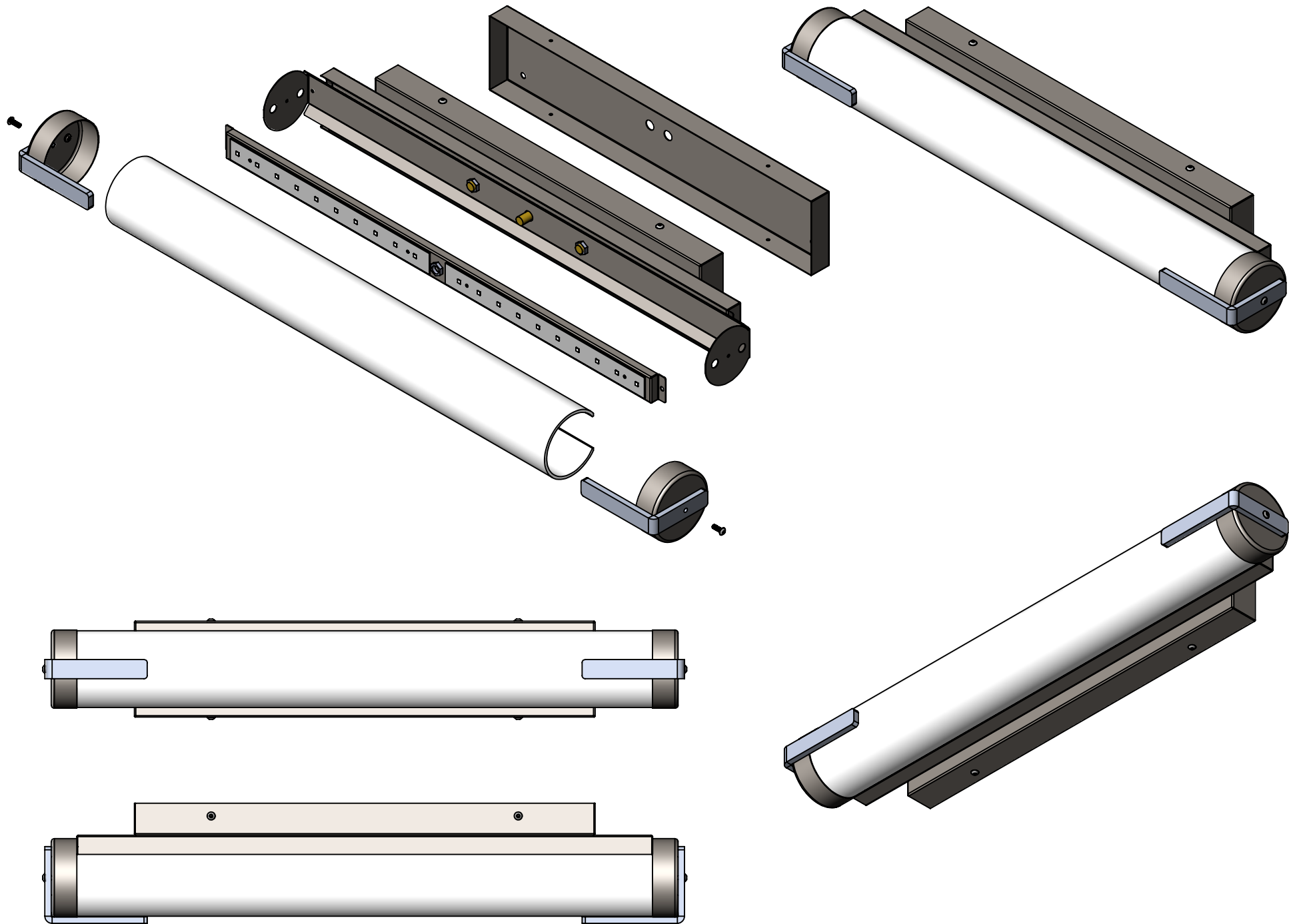

**\*ALL COMPONENTS TO BE SPOT  
WELDED INTO ONE PIECE**

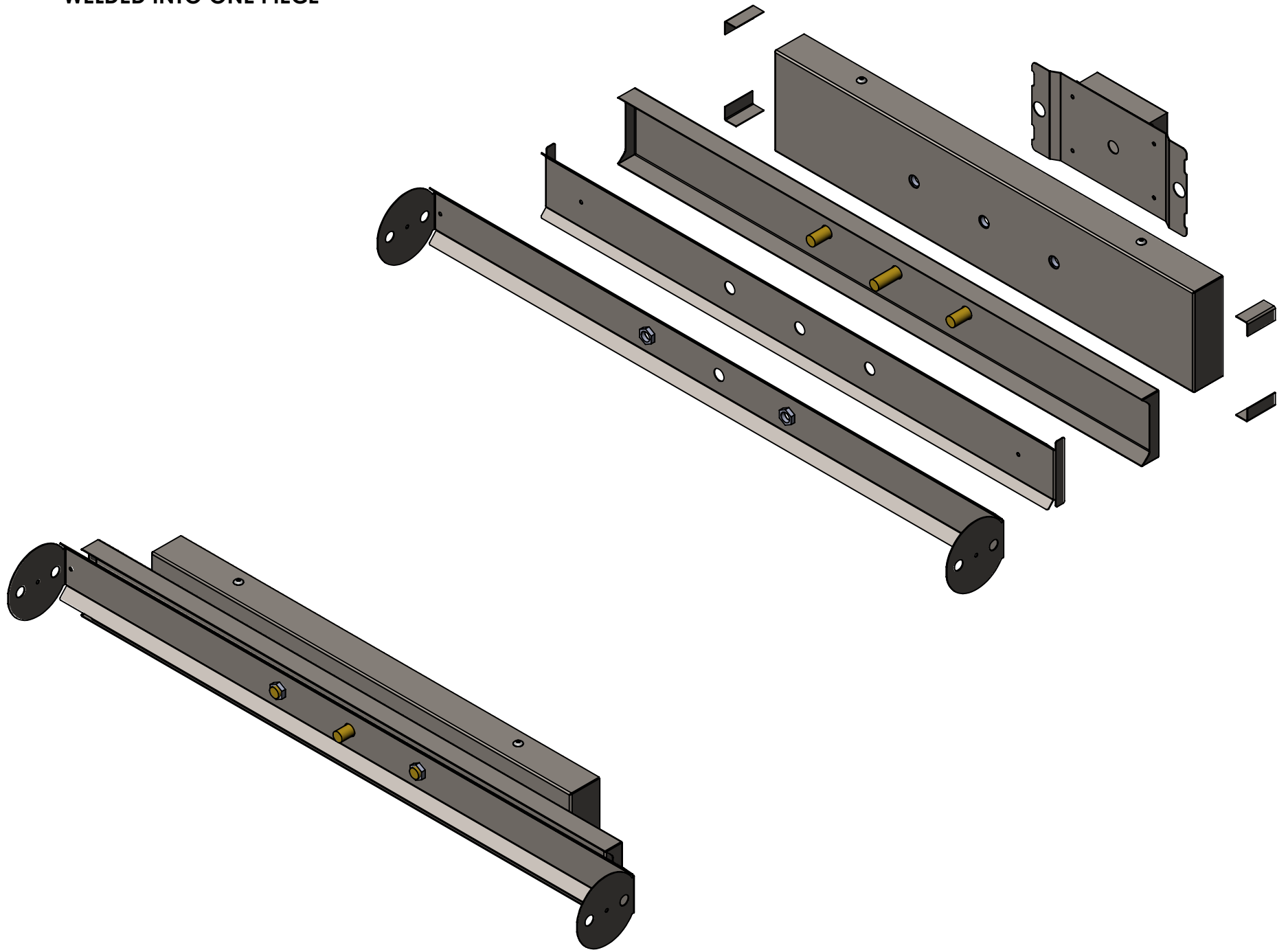

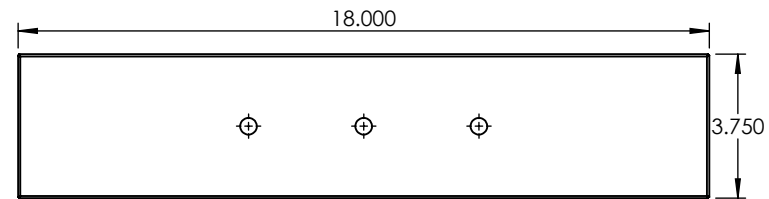
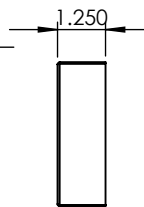
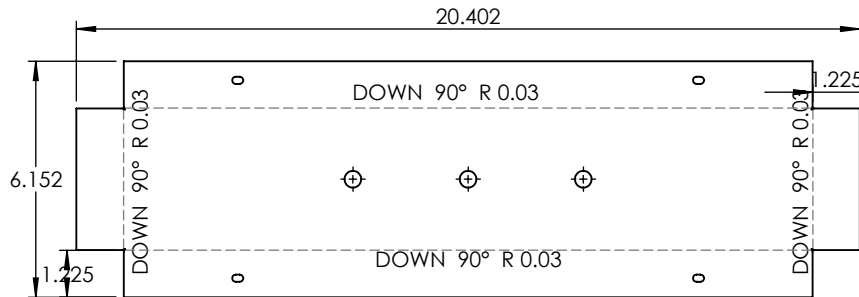
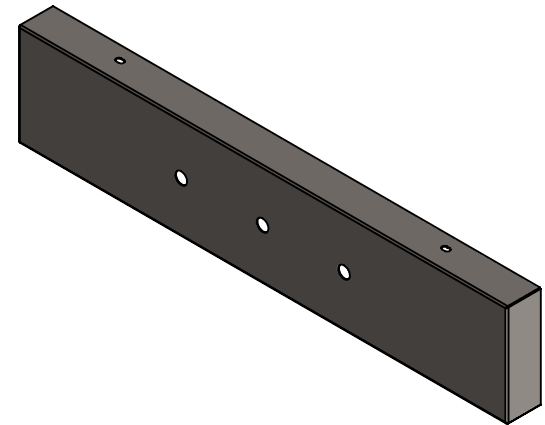
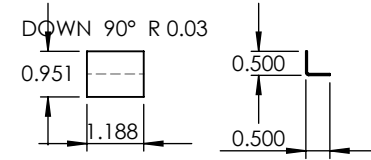
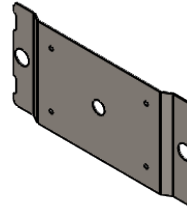
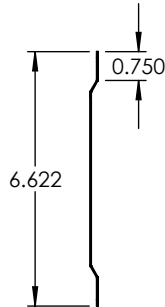
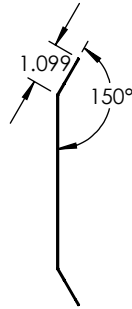
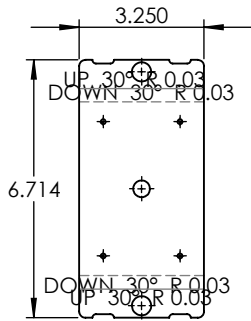

UNLESS OTHERWISE SPECIFIED:

DIMENSIONS ARE IN INCHES  
 TOLERANCES:  
 FRACTIONAL ±  
 ANGULAR: MACH ± BEND ±  
 TWO PLACE DECIMAL ±  
 THREE PLACE DECIMAL ±

INTERPRET GEOMETRIC  
 TOLERANCING PER:

MATERIAL

FINISH

DO NOT SCALE DRAWING

NAME DATE

DRAWN  
 CHECKED  
 ENG APPR.  
 MFG APPR.

Q.A.  
 COMMENTS:

22 GAUGE

TITLE:

CYL-VBB-FGR-20W-MN-WF-DIM-25"-30K

**PROPRIETARY AND CONFIDENTIAL**  
 THE INFORMATION CONTAINED IN THIS  
 DRAWING IS THE SOLE PROPERTY OF  
 <INSERT COMPANY NAME HERE>. ANY  
 REPRODUCTION IN PART OR AS A WHOLE  
 WITHOUT THE WRITTEN PERMISSION OF  
 <INSERT COMPANY NAME HERE> IS  
 PROHIBITED.

NEXT ASSY	USED ON
APPLICATION	

SIZE <b>A</b>	DWG. NO.	REV
SCALE: 1:5	WEIGHT:	SHEET 4 OF 11

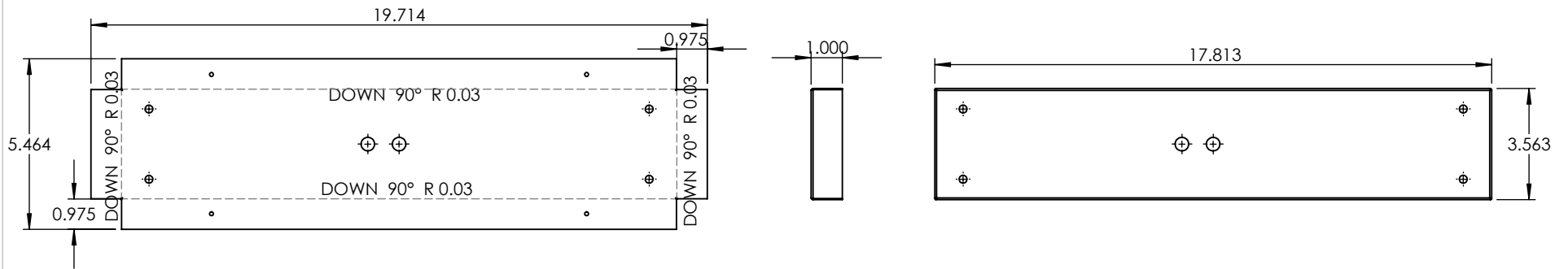
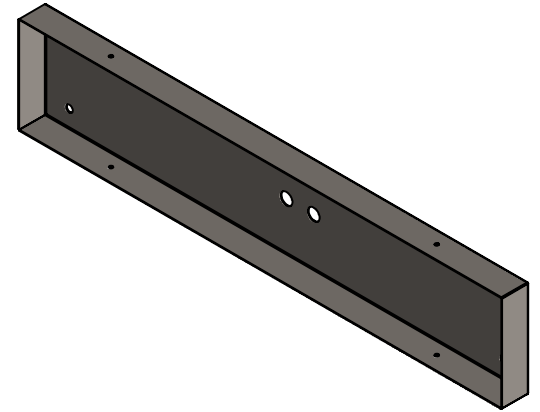

UNLESS OTHERWISE SPECIFIED:

DIMENSIONS ARE IN INCHES  
 TOLERANCES:  
 FRACTIONAL ±  
 ANGULAR: MACH ± BEND ±  
 TWO PLACE DECIMAL ±  
 THREE PLACE DECIMAL ±

INTERPRET GEOMETRIC  
 TOLERANCING PER:

MATERIAL

FINISH

DO NOT SCALE DRAWING

NAME

DATE

22 GAUGE

DRAWN

CHECKED

ENG APPR.

MFG APPR.

Q.A.

COMMENTS:

TITLE:

CYL-VBB-FGR-20W-MN-WF-DIM-25"-30K

SIZE  
**A**

DWG. NO.

REV

SCALE: 1:5

WEIGHT:

SHEET 5 OF 11

**PROPRIETARY AND CONFIDENTIAL**  
 THE INFORMATION CONTAINED IN THIS  
 DRAWING IS THE SOLE PROPERTY OF  
 <INSERT COMPANY NAME HERE>. ANY  
 REPRODUCTION IN PART OR AS A WHOLE  
 WITHOUT THE WRITTEN PERMISSION OF  
 <INSERT COMPANY NAME HERE> IS  
 PROHIBITED.

NEXT ASSY

USED ON

APPLICATION

5

4

3

2

1

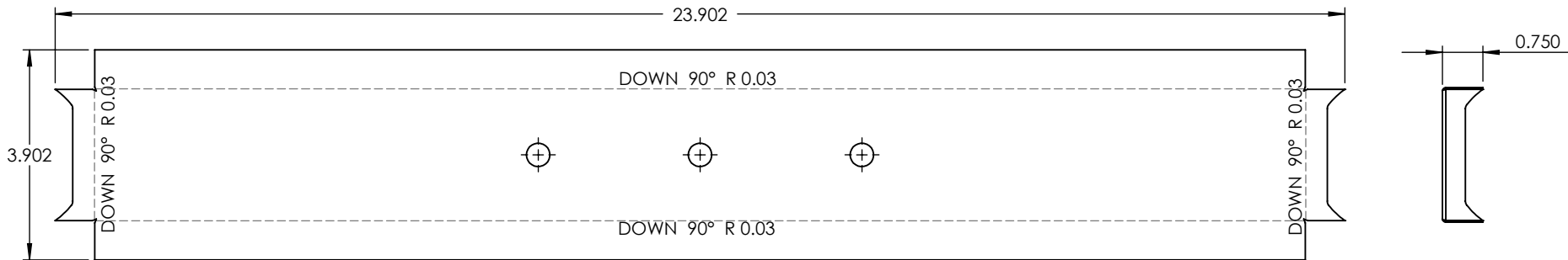
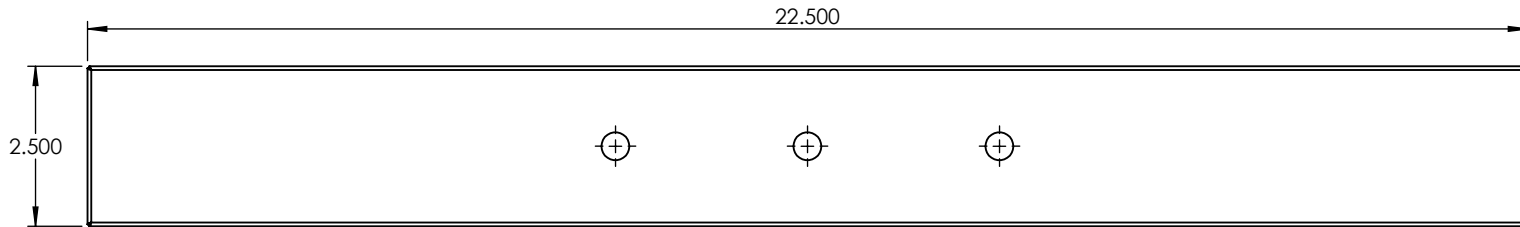
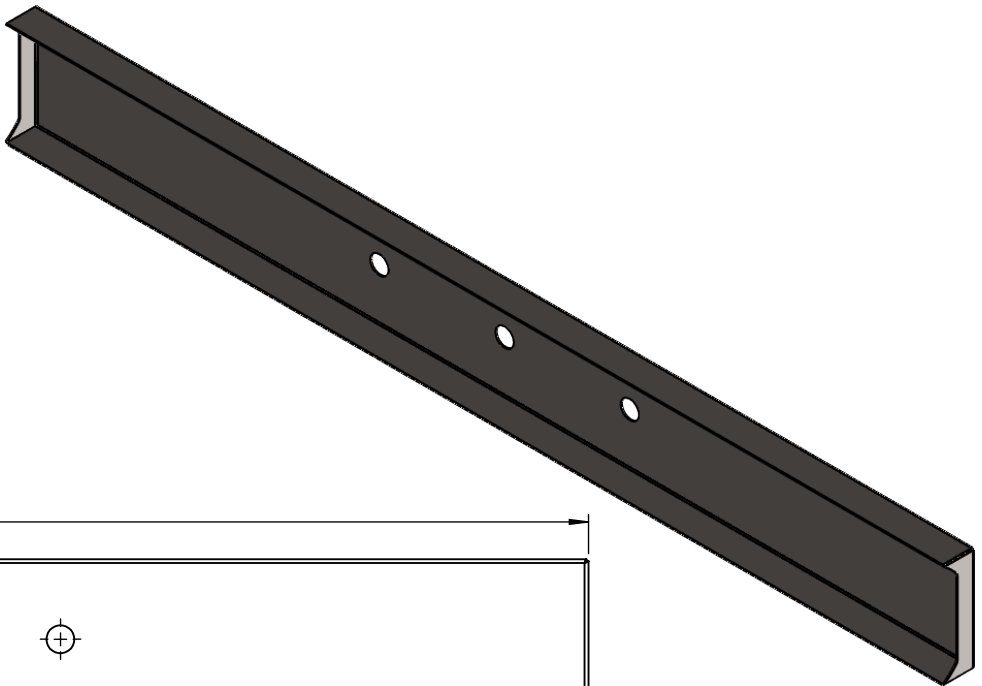

**PROPRIETARY AND CONFIDENTIAL**  
 THE INFORMATION CONTAINED IN THIS DRAWING IS THE SOLE PROPERTY OF <INSERT COMPANY NAME HERE>. ANY REPRODUCTION IN PART OR AS A WHOLE WITHOUT THE WRITTEN PERMISSION OF <INSERT COMPANY NAME HERE> IS PROHIBITED.

		UNLESS OTHERWISE SPECIFIED:	NAME	DATE
		DIMENSIONS ARE IN INCHES	DRAWN	
		TOLERANCES:	CHECKED	
		FRACTIONAL ±	ENG APPR.	
		ANGULAR: MACH ± BEND ±	MFG APPR.	
		TWO PLACE DECIMAL ±	Q.A.	
		THREE PLACE DECIMAL ±	COMMENTS:	
		INTERPRET GEOMETRIC TOLERANCING PER:		
		MATERIAL		
		FINISH		
	NEXT ASSY	USED ON		
	APPLICATION	DO NOT SCALE DRAWING		

<b>22 GAUGE</b>		
TITLE:		
<b>CYL-VBB-FGR-20W-MN-WF-DIM-25"-30K</b>		
SIZE	DWG. NO.	REV
<b>A</b>		
SCALE: 1:6	WEIGHT:	SHEET 6 OF 11

5

4

3

2

1

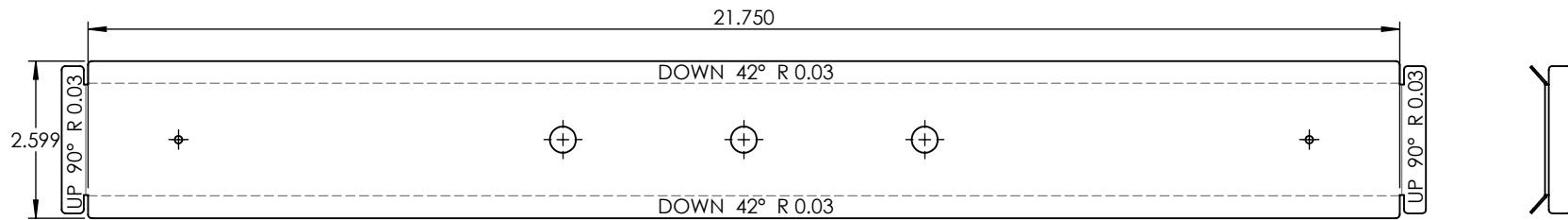
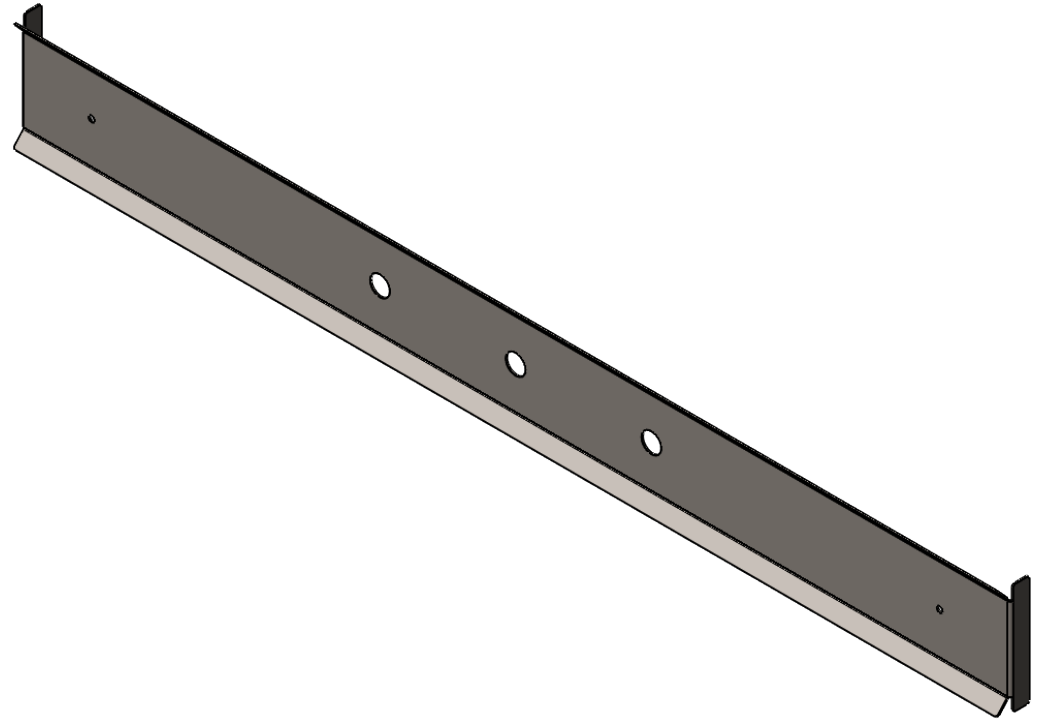
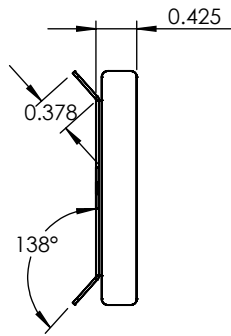

UNLESS OTHERWISE SPECIFIED:

DIMENSIONS ARE IN INCHES  
 TOLERANCES:  
 FRACTIONAL ±  
 ANGULAR: MACH ± BEND ±  
 TWO PLACE DECIMAL ±  
 THREE PLACE DECIMAL ±

INTERPRET GEOMETRIC  
 TOLERANCING PER:

MATERIAL

FINISH

DO NOT SCALE DRAWING

NAME

DATE

22 GAUGE

DRAWN

CHECKED

ENG APPR.

MFG APPR.

Q.A.

COMMENTS:

TITLE:

CYL-VBB-FGR-20W-MN-WF-DIM-25"-30K

SIZE  
**A**

DWG. NO.

REV

SCALE: 1:3

WEIGHT:

SHEET 7 OF 11

**PROPRIETARY AND CONFIDENTIAL**

THE INFORMATION CONTAINED IN THIS DRAWING IS THE SOLE PROPERTY OF <INSERT COMPANY NAME HERE>. ANY REPRODUCTION IN PART OR AS A WHOLE WITHOUT THE WRITTEN PERMISSION OF <INSERT COMPANY NAME HERE> IS PROHIBITED.

NEXT ASSY	USED ON
APPLICATION	

5

4

3

2

1

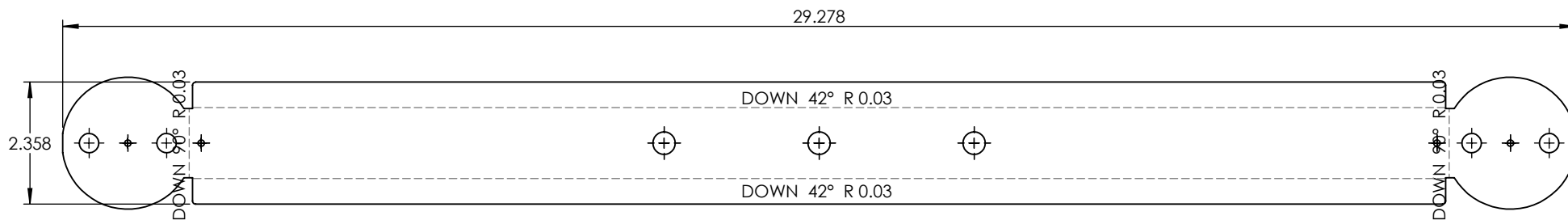
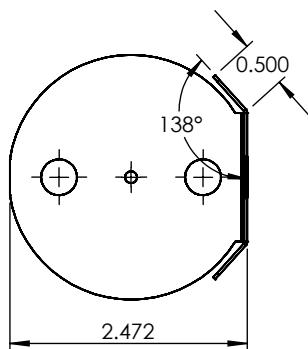
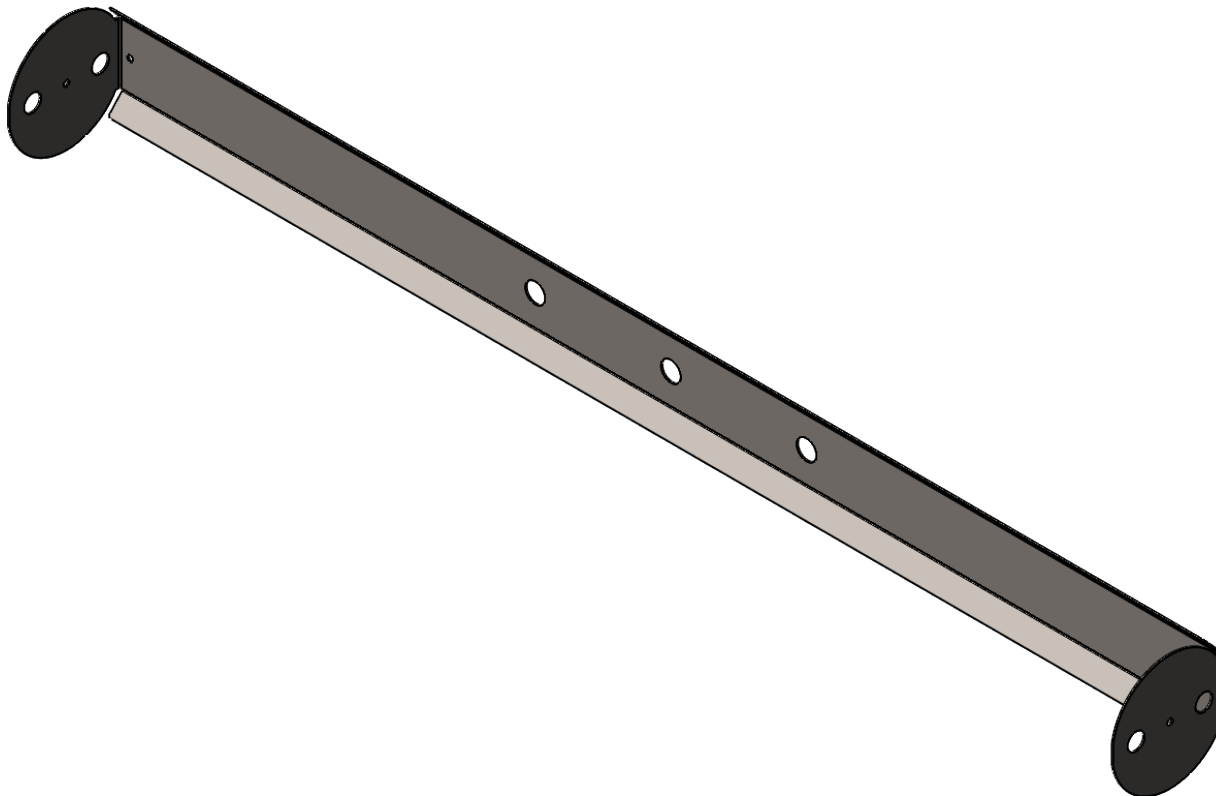

UNLESS OTHERWISE SPECIFIED:		NAME	DATE	22 GAUGE	
DIMENSIONS ARE IN INCHES TOLERANCES: FRACTIONAL ± ANGULAR: MACH ± BEND ± TWO PLACE DECIMAL ± THREE PLACE DECIMAL ±		DRAWN			
INTERPRET GEOMETRIC TOLERANCING PER:		CHECKED		SIZE DWG. NO. REV	
MATERIAL		ENG APPR.			
FINISH		MFG APPR.		DO NOT SCALE DRAWING	
APPLICATION		Q.A.			
		COMMENTS:			

**PROPRIETARY AND CONFIDENTIAL**  
 THE INFORMATION CONTAINED IN THIS DRAWING IS THE SOLE PROPERTY OF <INSERT COMPANY NAME HERE>. ANY REPRODUCTION IN PART OR AS A WHOLE WITHOUT THE WRITTEN PERMISSION OF <INSERT COMPANY NAME HERE> IS PROHIBITED.



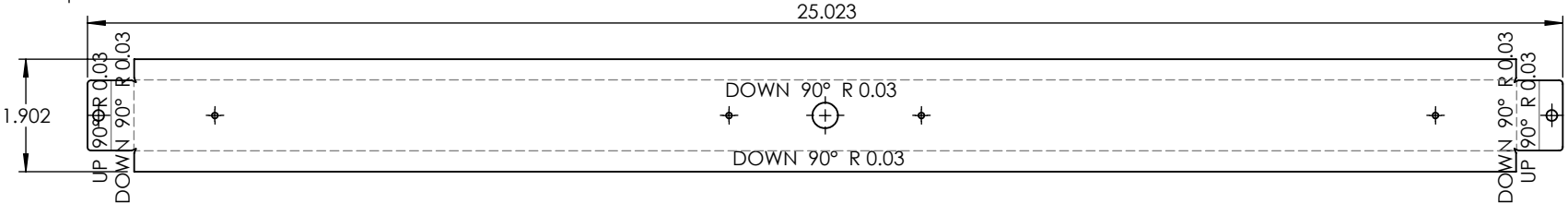
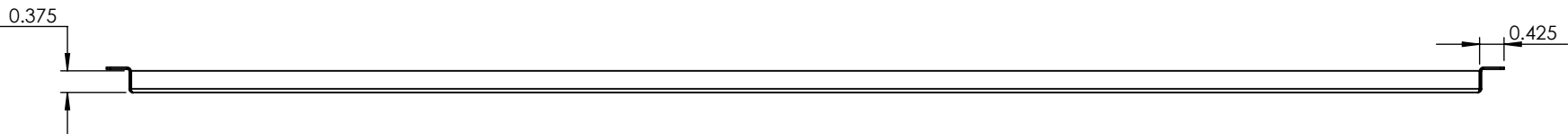
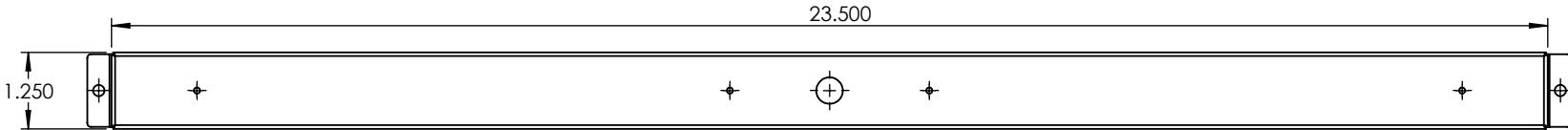
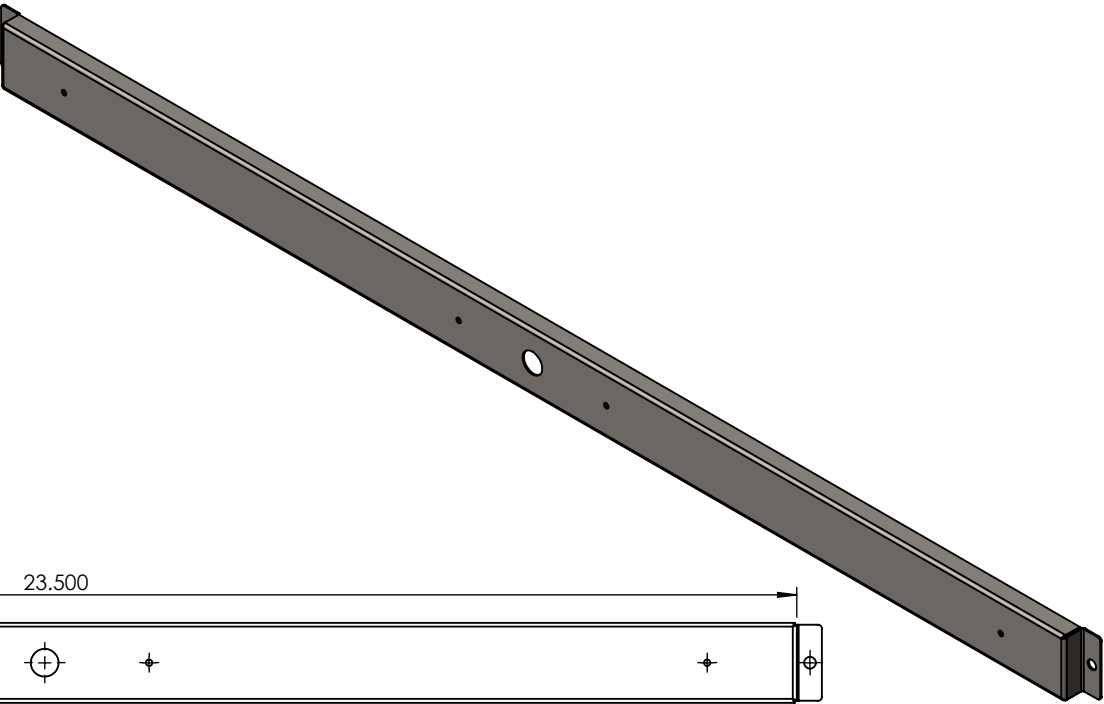

UNLESS OTHERWISE SPECIFIED:

DIMENSIONS ARE IN INCHES  
 TOLERANCES:  
 FRACTIONAL ±  
 ANGULAR: MACH ± BEND ±  
 TWO PLACE DECIMAL ±  
 THREE PLACE DECIMAL ±

INTERPRET GEOMETRIC TOLERANCING PER:

MATERIAL

FINISH

DO NOT SCALE DRAWING

NAME DATE

DRAWN  
 CHECKED  
 ENG APPR.  
 MFG APPR.

Q.A.

COMMENTS:

22 GAUGE

TITLE:

CYL-VBB-FGR-20W-MN-WF-DIM-25"-30K

**PROPRIETARY AND CONFIDENTIAL**  
 THE INFORMATION CONTAINED IN THIS DRAWING IS THE SOLE PROPERTY OF <INSERT COMPANY NAME HERE>. ANY REPRODUCTION IN PART OR AS A WHOLE WITHOUT THE WRITTEN PERMISSION OF <INSERT COMPANY NAME HERE> IS PROHIBITED.

NEXT ASSY	USED ON
APPLICATION	

SIZE	DWG. NO.	REV
<b>A</b>		
SCALE: 1:3	WEIGHT:	SHEET 9 OF 11

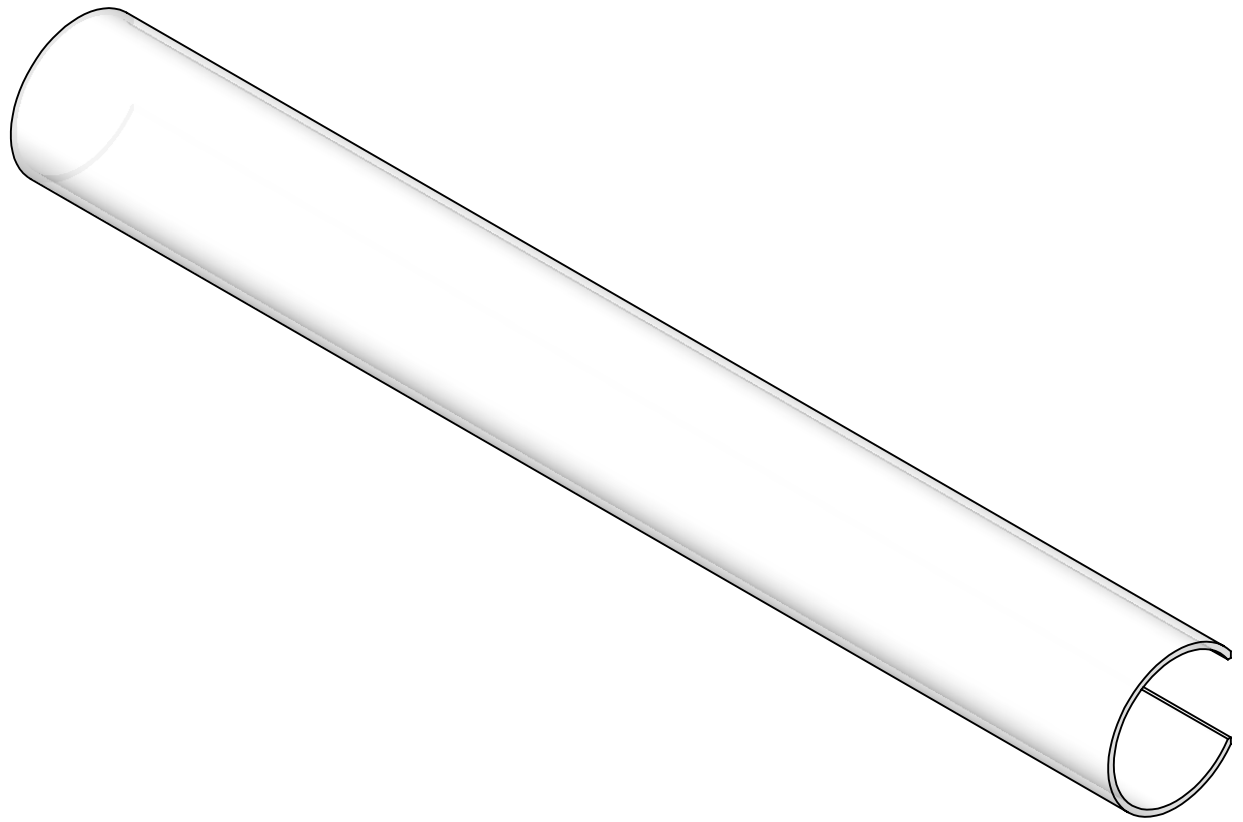

24 1/4"

Ø 3"

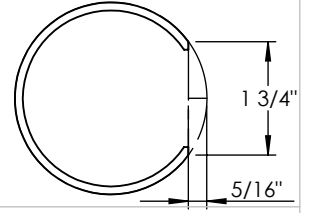

**PROPRIETARY AND CONFIDENTIAL**  
 THE INFORMATION CONTAINED IN THIS DRAWING IS THE SOLE PROPERTY OF <INSERT COMPANY NAME HERE>. ANY REPRODUCTION IN PART OR AS A WHOLE WITHOUT THE WRITTEN PERMISSION OF <INSERT COMPANY NAME HERE> IS PROHIBITED.

		UNLESS OTHERWISE SPECIFIED:		NAME	DATE
		DIMENSIONS ARE IN INCHES	DRAWN		
		TOLERANCES:	CHECKED		
		FRACTIONAL ±	ENG APPR.		
		ANGULAR: MACH ± BEND ±	MFG APPR.		
		TWO PLACE DECIMAL ±	Q.A.		
		THREE PLACE DECIMAL ±	COMMENTS:		
		INTERPRET GEOMETRIC TOLERANCING PER:			
		MATERIAL			
		FINISH			
NEXT ASSY	USED ON				
APPLICATION		DO NOT SCALE DRAWING			

ACRYLIC		
TITLE:		
CYL-VBB-FGR-20W-MN-WF-DIM-25"-30K		
SIZE	DWG. NO.	REV
<b>A</b>		
SCALE: 1:3	WEIGHT:	SHEET 10 OF 11

5

4

3

2

1

ITEM NO.	PART NUMBER	DESCRIPTION	QTY.
1	CYL-VBB-FGR-20W-MN-WF-DIM-25"-30K-SPUN CUP	SPUN 22 GAUGE	1

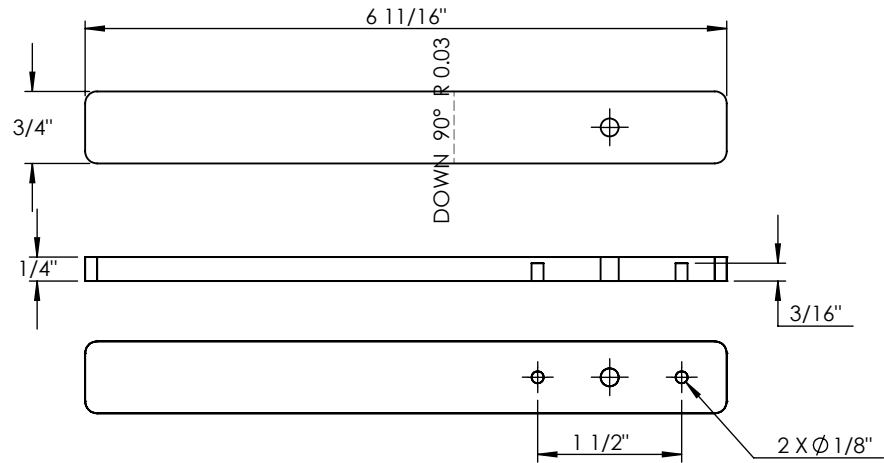
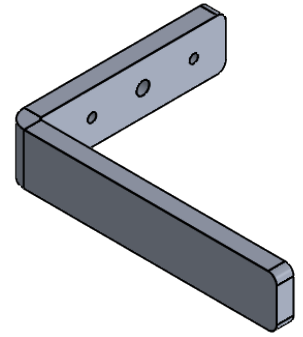
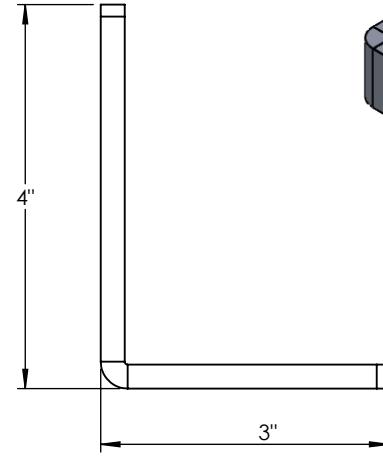
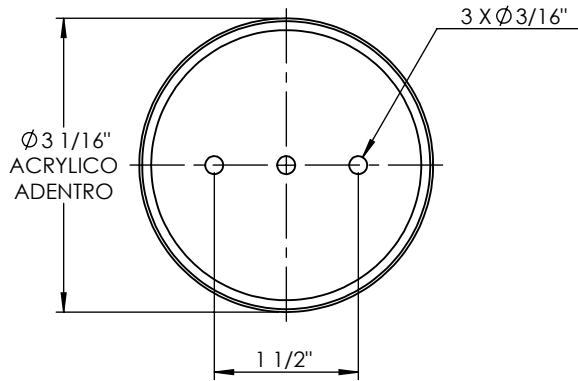
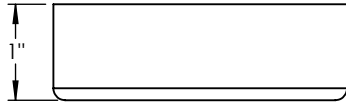
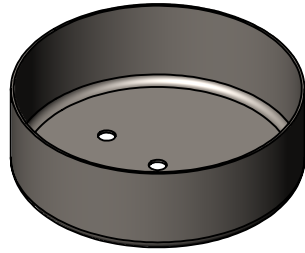

**PROPRIETARY AND CONFIDENTIAL**  
 THE INFORMATION CONTAINED IN THIS DRAWING IS THE SOLE PROPERTY OF <INSERT COMPANY NAME HERE>. ANY REPRODUCTION IN PART OR AS A WHOLE WITHOUT THE WRITTEN PERMISSION OF <INSERT COMPANY NAME HERE> IS PROHIBITED.

		UNLESS OTHERWISE SPECIFIED:	NAME	DATE	SPUN 22 GAUGE	
		DIMENSIONS ARE IN INCHES TOLERANCES: FRACTIONAL ± ANGULAR: MACH ± BEND ± TWO PLACE DECIMAL ± THREE PLACE DECIMAL ±	DRAWN			
		INTERPRET GEOMETRIC TOLERANCING PER:	CHECKED		CYL-VBB-FGR-20W-MN-WF-DIM-25"-30K	
		MATERIAL	ENG APPR.			
		FINISH	MFG APPR.		SIZE	DWG. NO.
NEXT ASSY	USED ON		Q.A.		<b>A</b>	REV
APPLICATION		DO NOT SCALE DRAWING	COMMENTS:			SCALE: 1:2
5	4	3	2	1	SHEET 11 OF 11	