

EVERGREEN LIGHTING

ALL BEND RADIUS .030"

UNLESS OTHERWISE SPECIFIED:

DIMENSIONS ARE IN INCHES
 TOLERANCES:
 FRACTIONAL ± .003
 ANGULAR: MACH ± .01 BEND ±
 TWO PLACE DECIMAL ±
 THREE PLACE DECIMAL ± .001

INTERPRET GEOMETRIC TOLERANCING PER:

MATERIAL

FINISH

	NAME	DATE
DRAWN		
CHECKED		
ENG APPR.		
MFG APPR.		
Q.A.		
COMMENTS:		

TITLE:

OR-30-42-8-L24-2-L-1-1-BK

SIZE	DWG. NO.	REV
A	TICKET 25865	
SCALE: 1:10	WEIGHT:	SHEET 1 OF 12

5

4

3

2

1

APPLICATION

DO NOT SCALE DRAWING

ITEM NO.	PART NUMBER	DESCRIPTION	QTY.	CUT
1	OR-30-42-8-L24-2-L-1-1-BK-BOLLARD BODY	CONCRETE BODY	1	
2	OR-30-42-8-L24-2-L-1-1-BK-BOLLARD CAP	CONCRETE CAP	1	
3	OR-30-42-8-L24-2-L-1-1-BK-ANCHOR PLATE	ALUMINUM 0.500" PLATE	1	
4	OR-30-42-8-L24-2-L-1-1-BK-LOUVER PLATE	ALUMINUM 0.250" PLATE	1	
5	OR-30-42-8-L24-2-L-1-1-BK-LOUVER PLATE TOP	ALUMINUM 0.250" PLATE	1	
6	OR-30-42-8-L24-2-L-1-1-BK-SPUN LENS CAP	SPUN ALUMINUM 0.080"	1	
7	OR-30-42-8-L24-2-L-1-1-BK-SPUN LENS CAP	SPUN ALUMINUM 0.080"	1	
8	OR-30-42-8-L24-2-L-1-1-BK-BOLLARD BODY COVER	ALUMINUM 0.0635"	1	
9	OR-30-42-8-L24-2-L-1-1-BK-FRAME HORIZONTAL LOUVER	ALUMINUM 0.0635"	5	
10	OR-30-42-8-L24-2-L-1-1-BK-TUBE BRACKET	ALUMINUM 0.0635"	1	
11	OR-30-42-8-L24-2-L-1-1-BK-DRIVER BRACKET	ALUMINUM 0.0635"	1	
12	OR-30-42-8-L24-2-L-1-1-BK-TOP HORIZONTAL LOUVER	ALUMINUM 0.0635"	1	
13	OR-30-42-8-L24-2-L-1-1-BK-0.375" REFLECTOR SPACER	1/2" ALUMINUM CYLINDER	12	
14	OR-30-42-8-L24-2-L-1-1-BK-0.375" REFLECTOR SPACER	3/8" ALUMINUM CYLINDER	4	
15	OR-30-42-8-L24-2-L-1-1-BK-SQUARE TUBE	1-1/2" SQUARE TUBE	1	
16	OR-30-42-8-L24-2-L-1-1-BK-THREADED ROD	1/4" THREADED ROD	4	
18	OR-30-42-8-L24-2-L-1-1-BK-ACRYLIC TUBE	ACRYLIC	1	
19	Espen VEL19070MVH-1	DRIVER	1	
20	AltAILED_PN1012_RevD	LED	8	

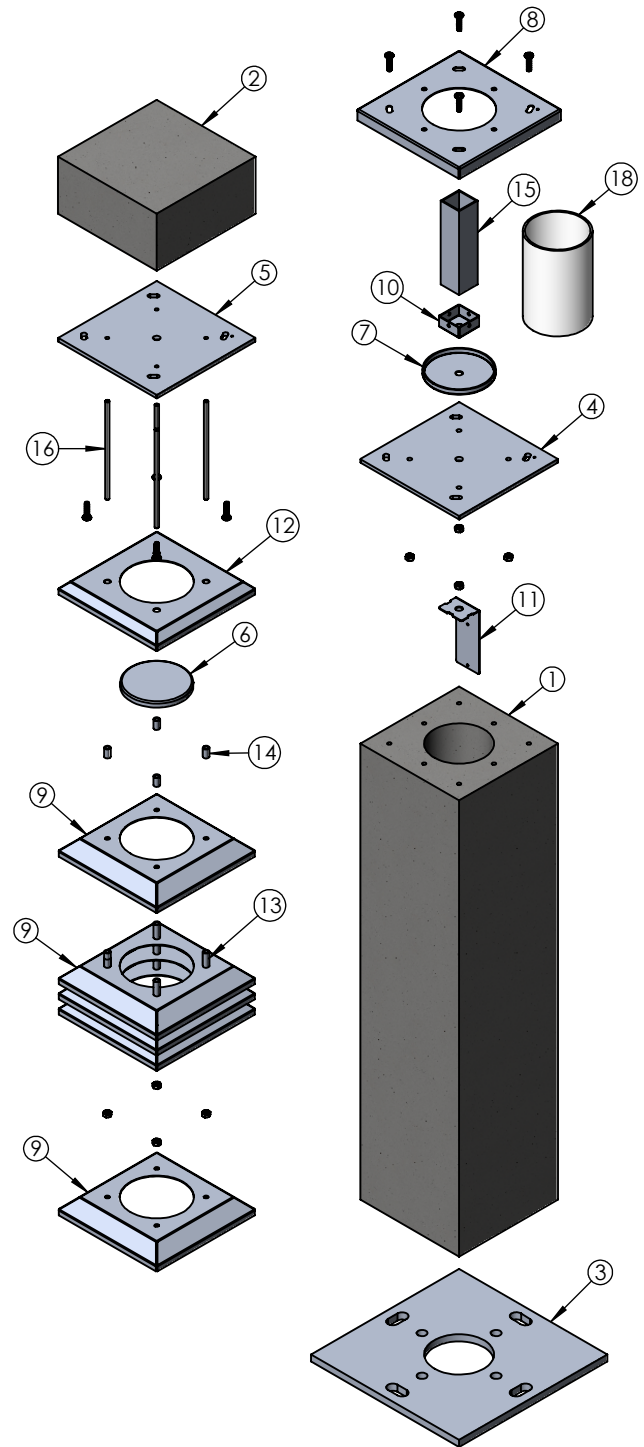

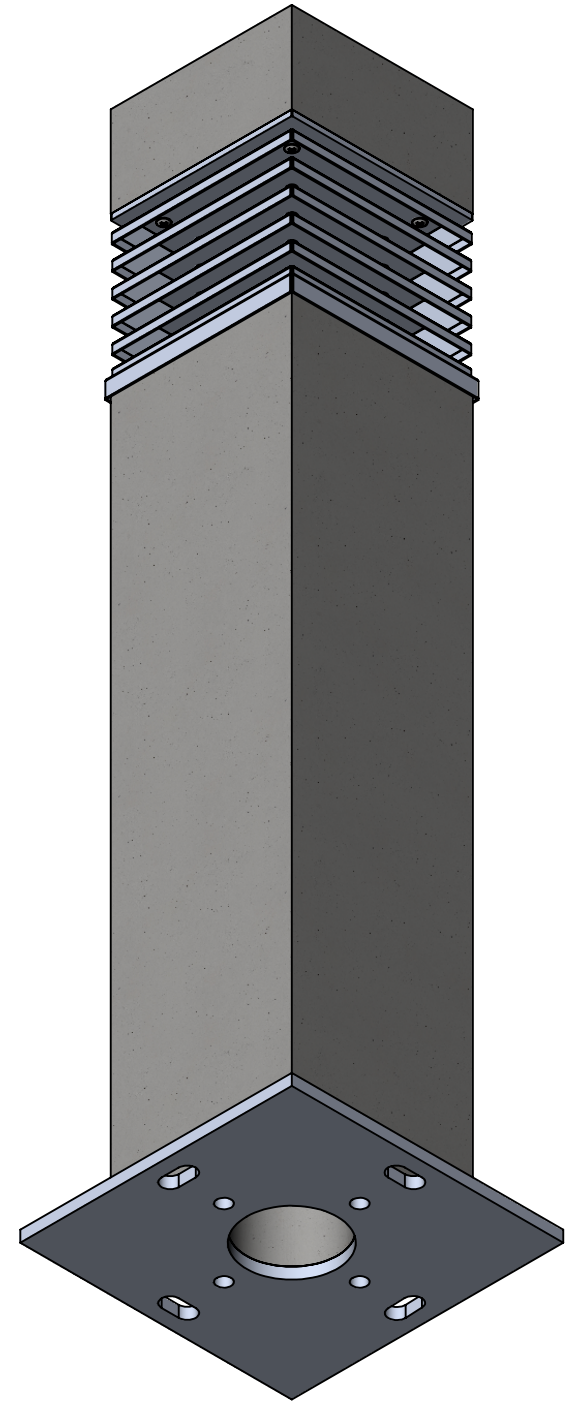
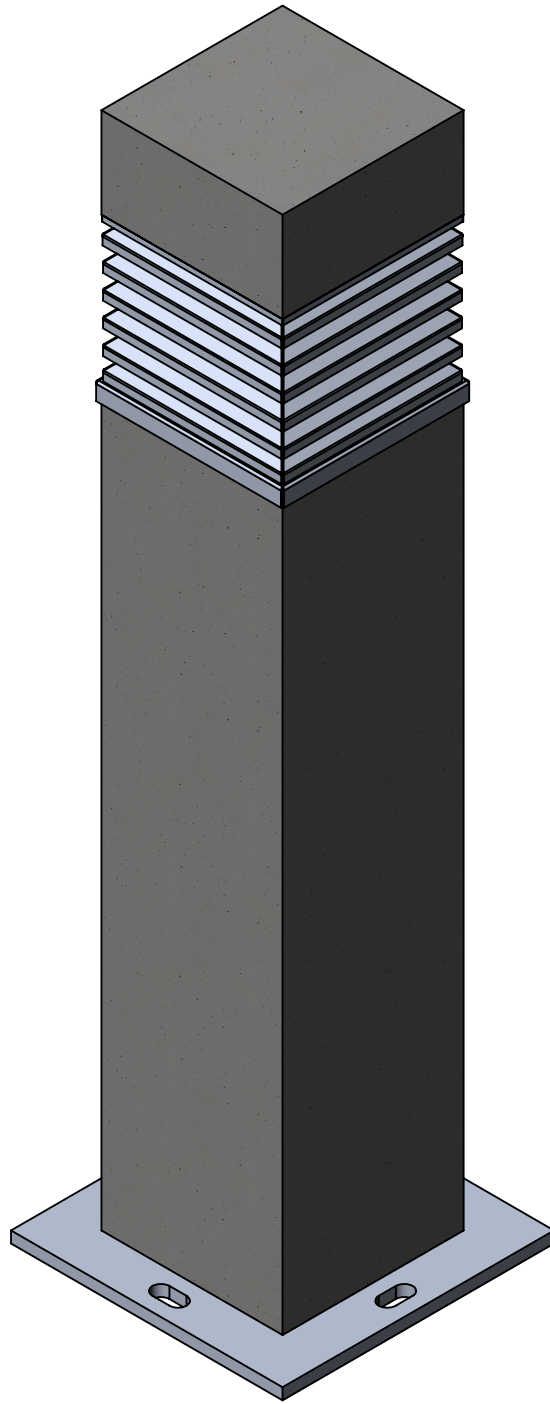

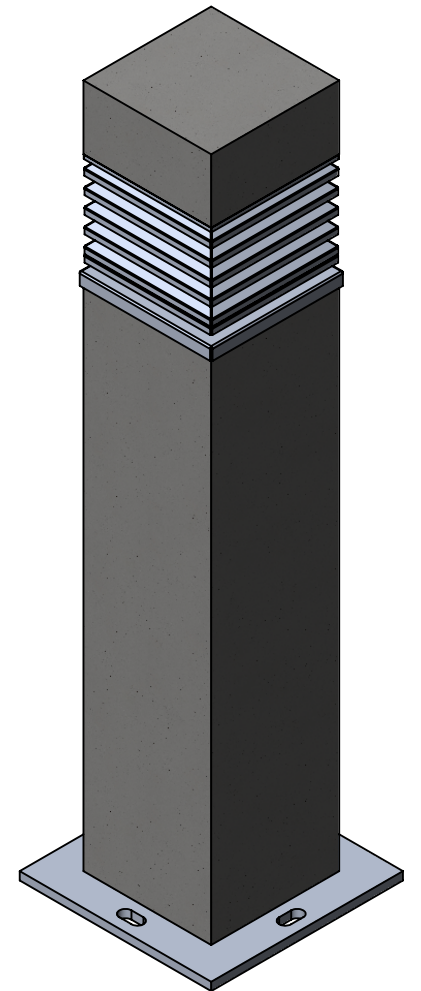
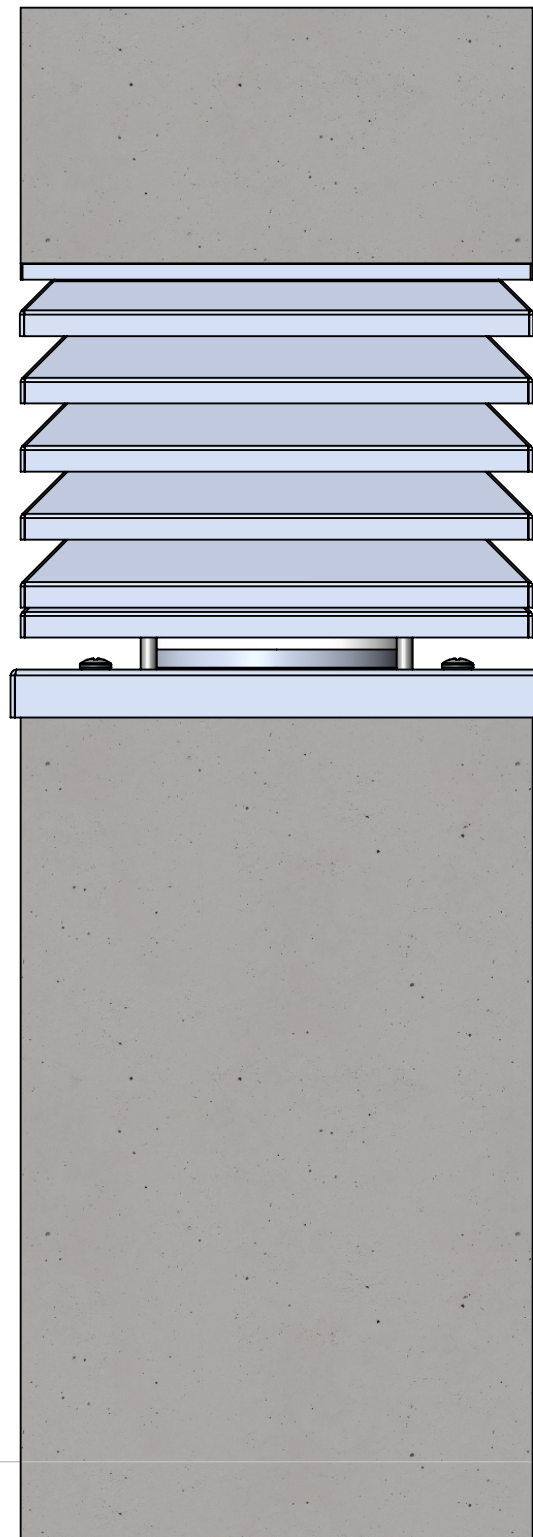
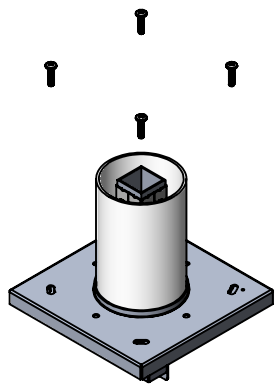
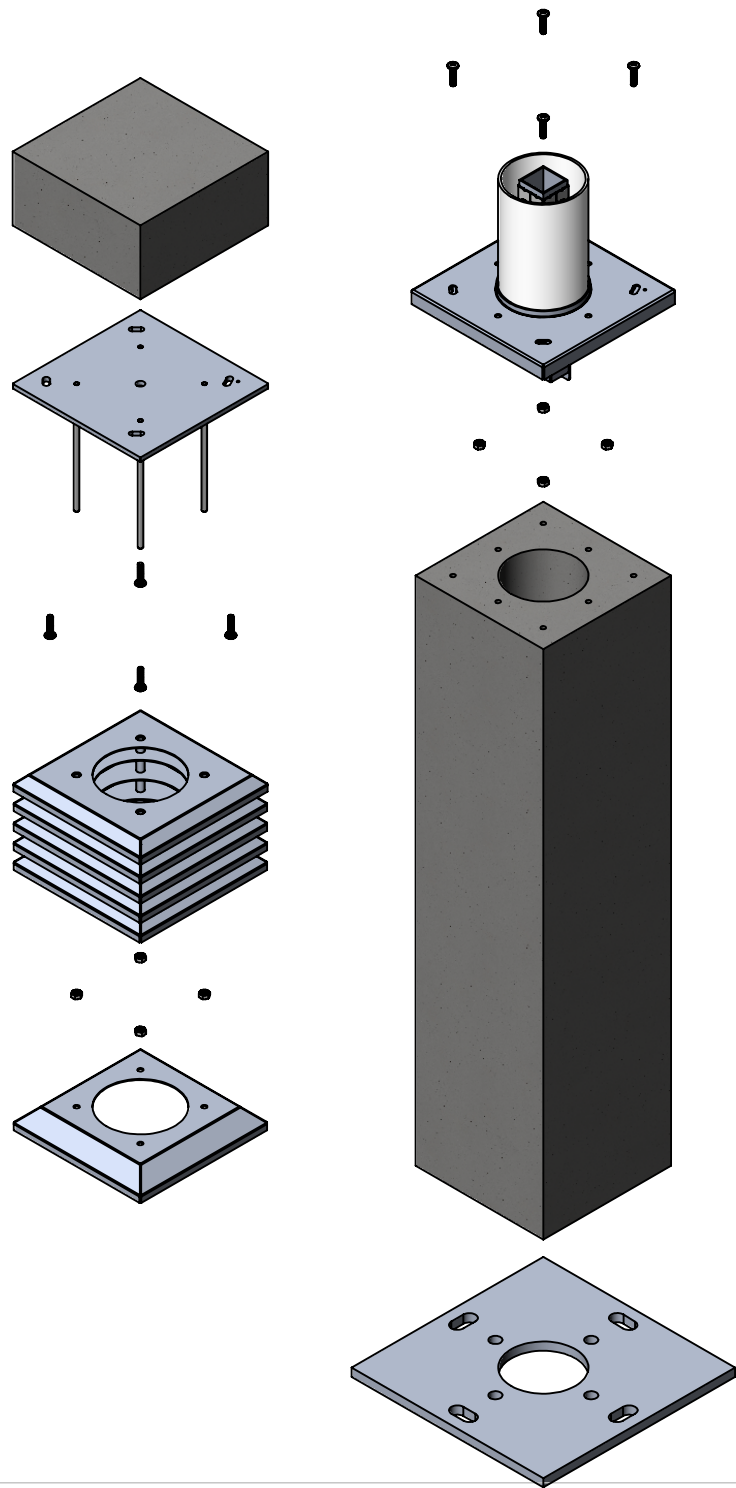

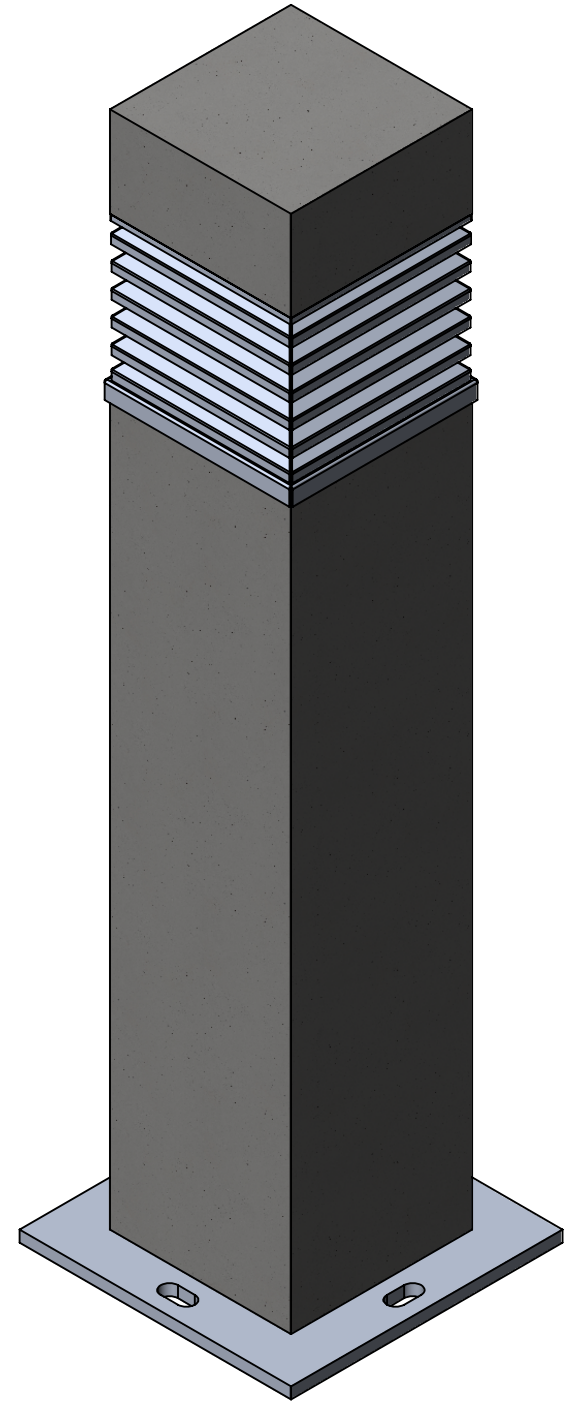
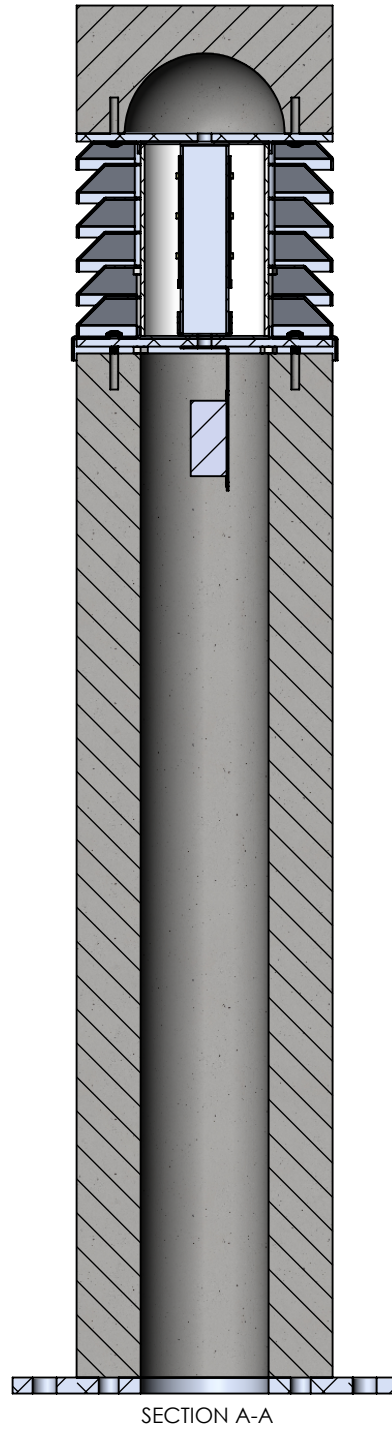
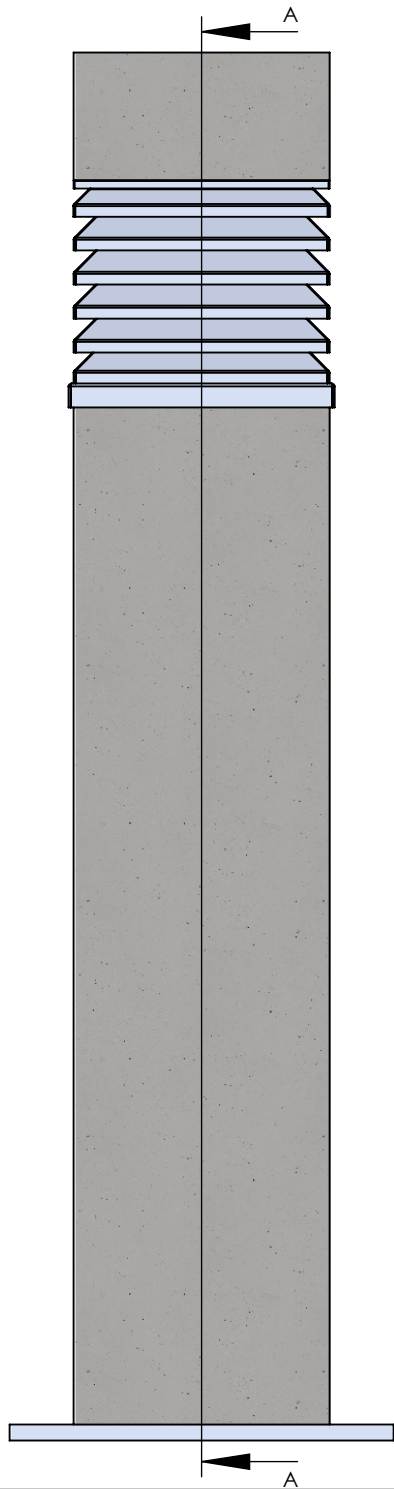

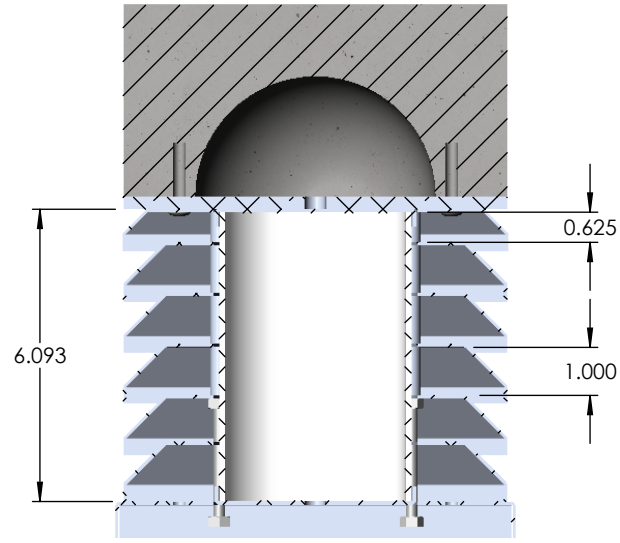
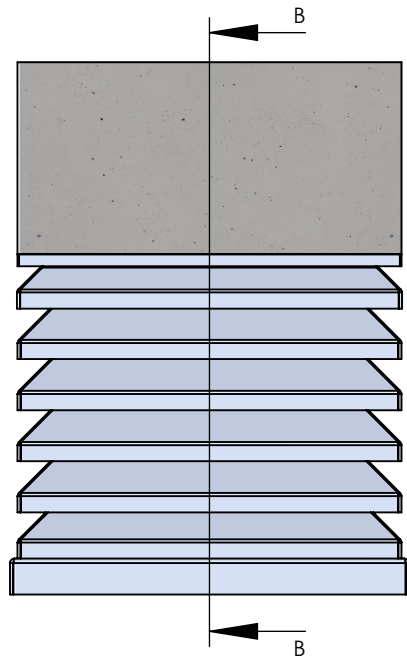

**X 1
TOP LOUVER**

**X 5
CENTER LOUVER**

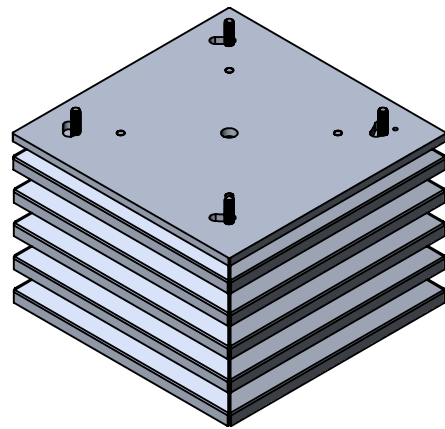
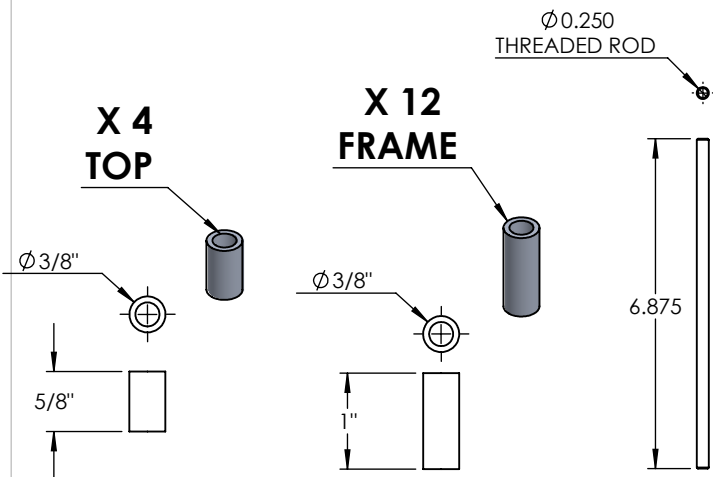
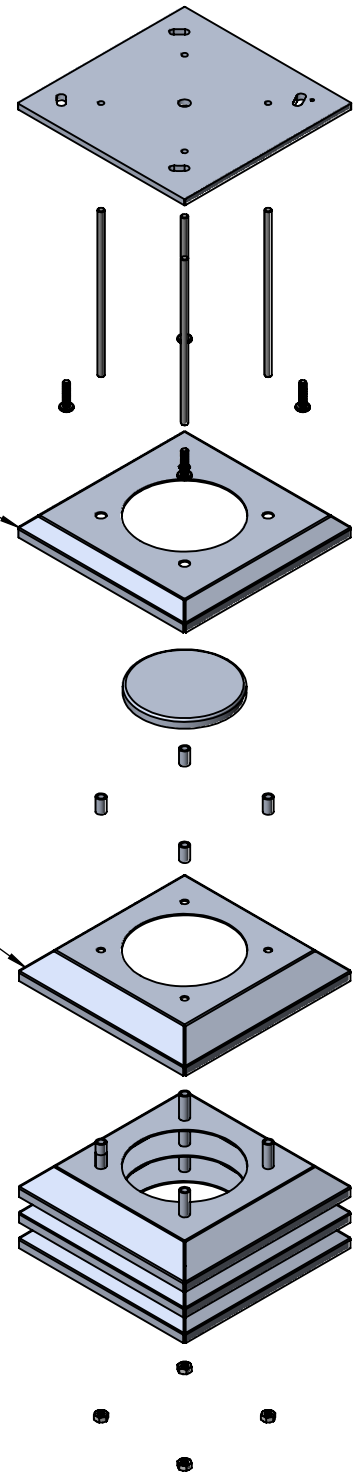

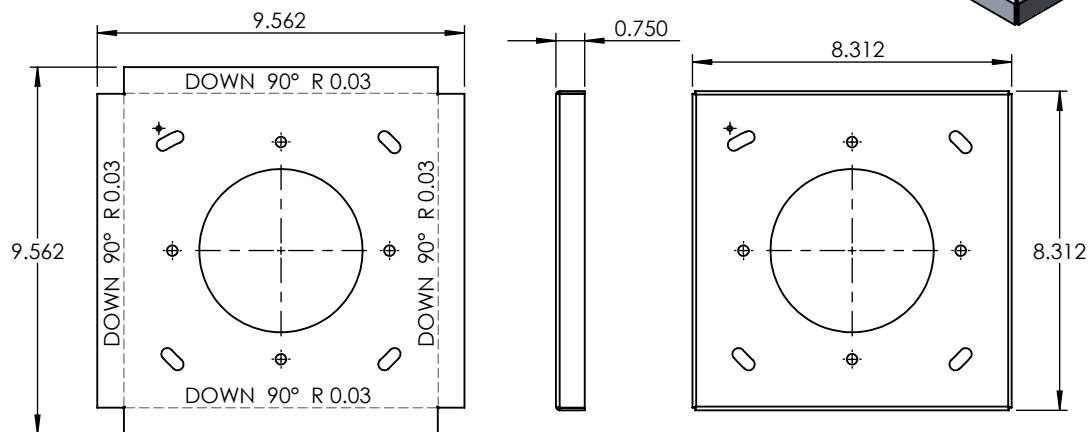
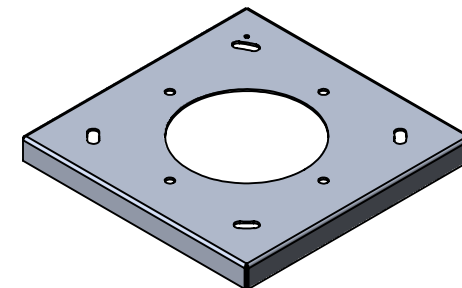
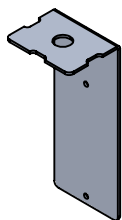
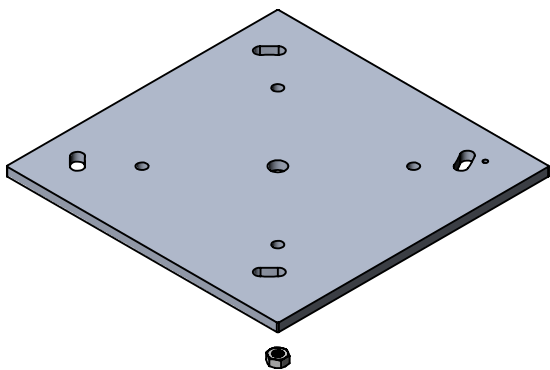
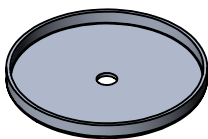
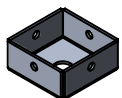
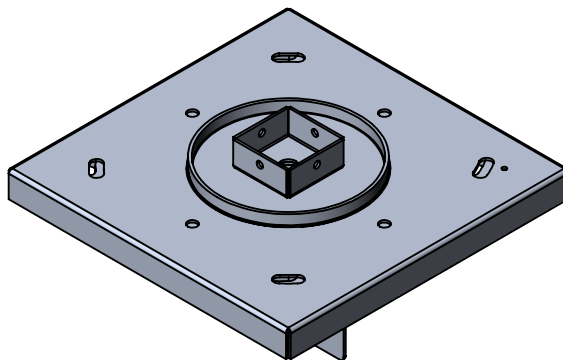
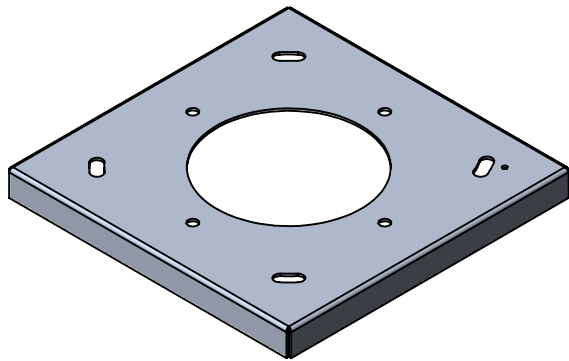

		UNLESS OTHERWISE SPECIFIED:	NAME	DATE	
		DIMENSIONS ARE IN INCHES	DRAWN		
		TOLERANCES:	CHECKED		TITLE:
		FRACTIONAL ±	ENG APPR.		OR-30-42-8-L24-2-L-1-1-BK
		ANGULAR: MACH ± BEND ±	MFG APPR.		
		TWO PLACE DECIMAL ±	Q.A.		SIZE DWG. NO. REV
		THREE PLACE DECIMAL ±	COMMENTS:		A
		INTERPRET GEOMETRIC TOLERANCING PER:			SCALE: 1:5 WEIGHT: SHEET 7 OF 12
		MATERIAL			
NEXT ASSY	USED ON	FINISH			
APPLICATION		DO NOT SCALE DRAWING			

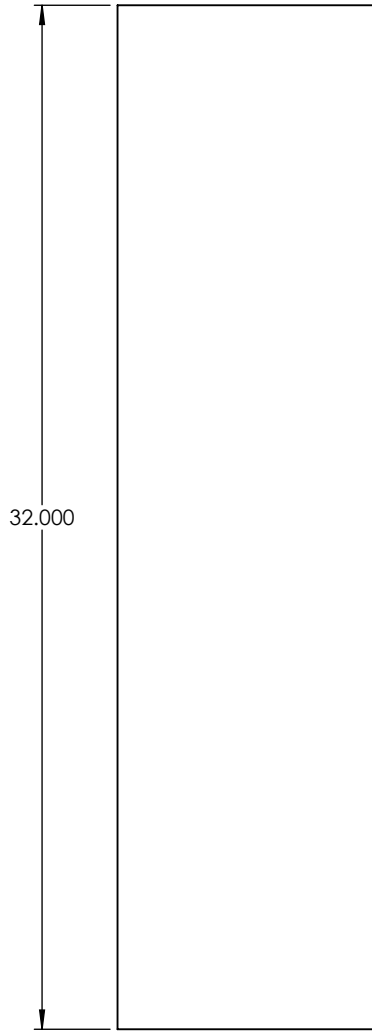
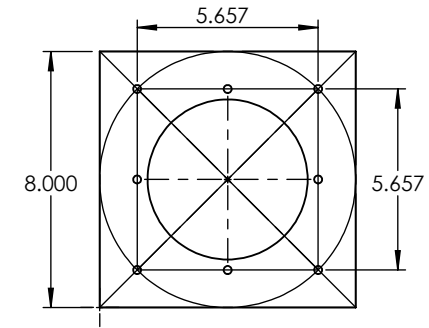
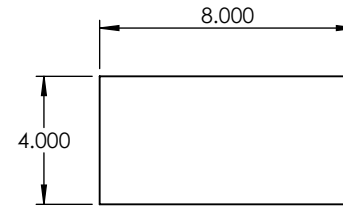
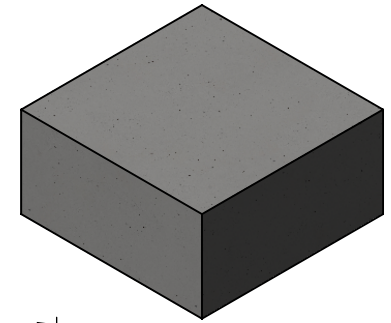
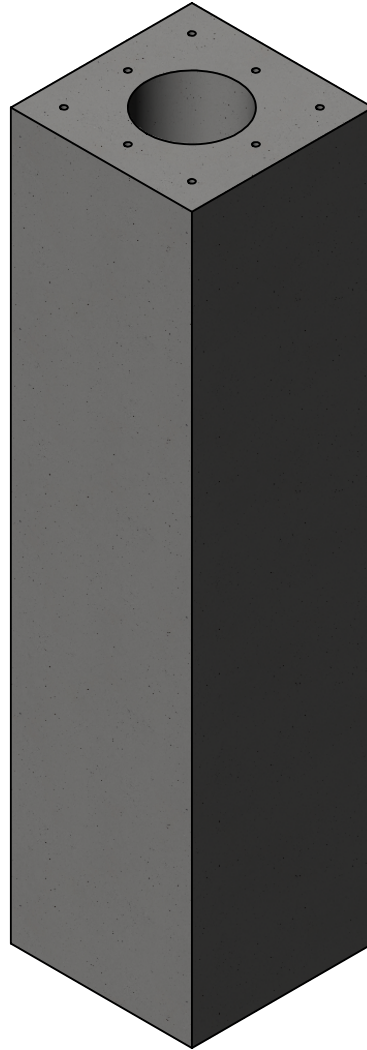
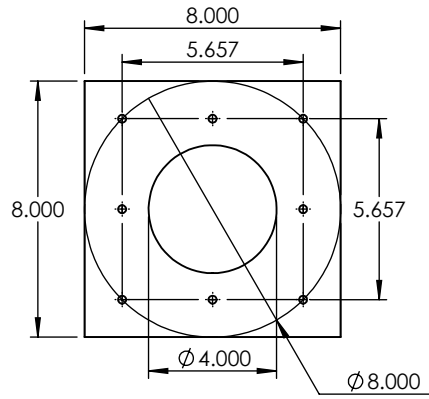

		UNLESS OTHERWISE SPECIFIED:	NAME	DATE	CONCRETE BODY	
		DIMENSIONS ARE IN INCHES	DRAWN			
		TOLERANCES:	CHECKED		OR-30-42-8-L24-2-L-1-1-BK	
		FRACTIONAL ±	ENG APPR.			
		ANGULAR: MACH ± BEND ±	MFG APPR.			
		TWO PLACE DECIMAL ±	Q.A.		SIZE	DWG. NO.
		THREE PLACE DECIMAL ±	COMMENTS:		A	
		INTERPRET GEOMETRIC TOLERANCING PER:			SCALE: 1:6	WEIGHT:
		MATERIAL			SHEET 8 OF 12	
NEXT ASSY	USED ON	FINISH				
APPLICATION		DO NOT SCALE DRAWING				

5

4

3

2

1

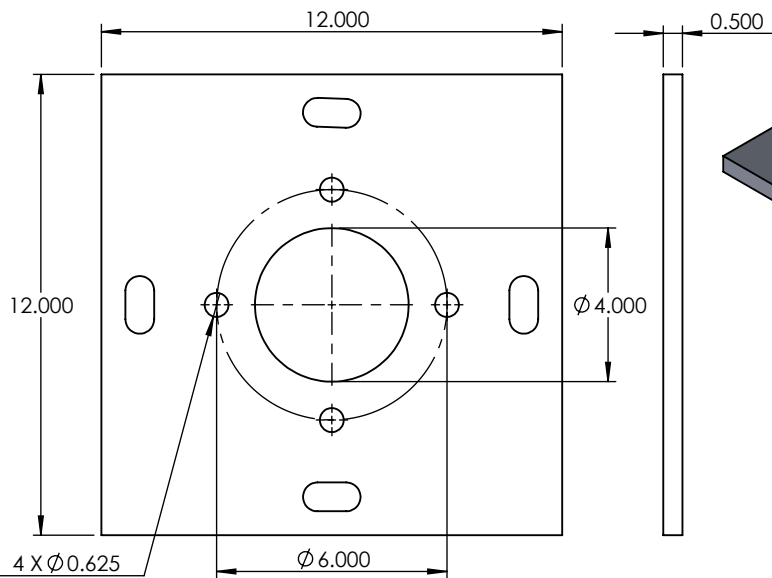
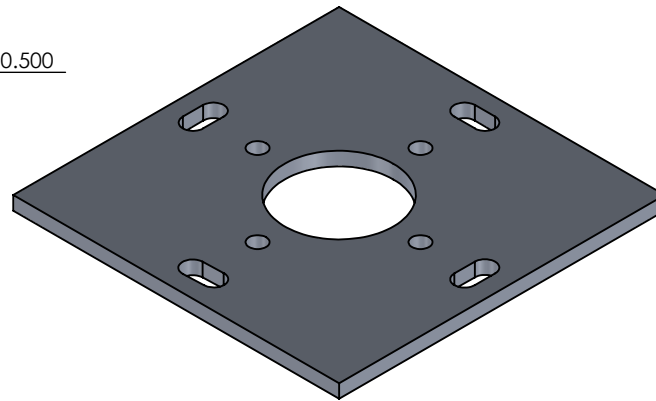
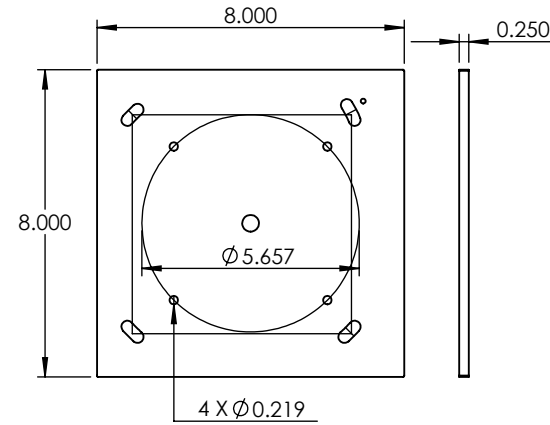
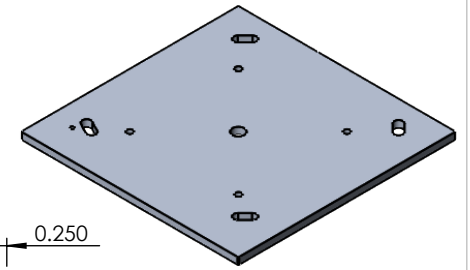
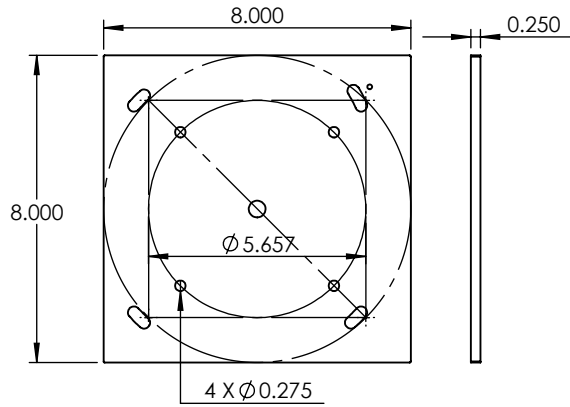
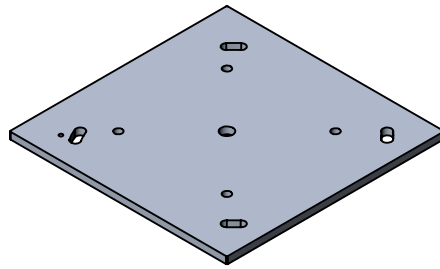

UNLESS OTHERWISE SPECIFIED:		NAME	DATE	ALUMINUM 0.250" PLATE
DIMENSIONS ARE IN INCHES TOLERANCES: FRACTIONAL ± ANGULAR: MACH ± BEND ± TWO PLACE DECIMAL ± THREE PLACE DECIMAL ±		DRAWN		
INTERPRET GEOMETRIC TOLERANCING PER:		CHECKED		OR-30-42-8-L24-2-L-1-1-BK
MATERIAL		ENG APPR.		
FINISH		MFG APPR.		REV
NEXT ASSY		Q.A.		SCALE: 1:5
USED ON		COMMENTS:		WEIGHT:
APPLICATION				SHEET 9 OF 12
DO NOT SCALE DRAWING				

PROPRIETARY AND CONFIDENTIAL
THE INFORMATION CONTAINED IN THIS DRAWING IS THE SOLE PROPERTY OF <INSERT COMPANY NAME HERE>. ANY REPRODUCTION IN PART OR AS A WHOLE WITHOUT THE WRITTEN PERMISSION OF <INSERT COMPANY NAME HERE> IS PROHIBITED.

**X 5
FRAME LOUVER**

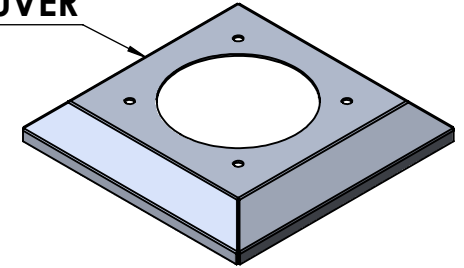
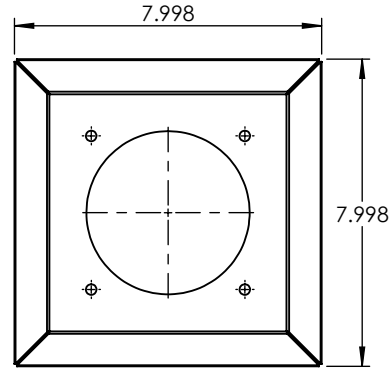
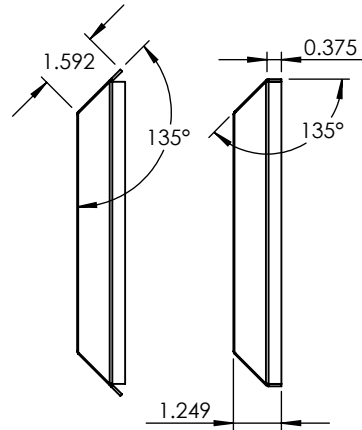
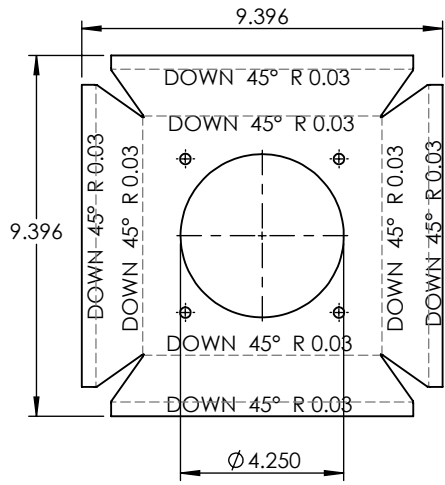

**X 1
TOP LOUVER**

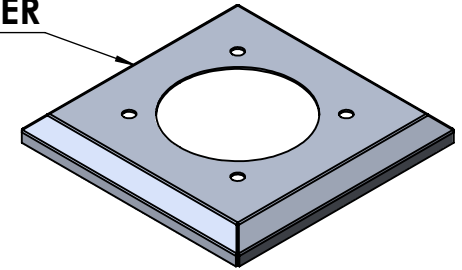
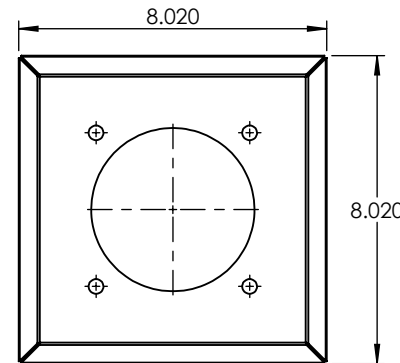
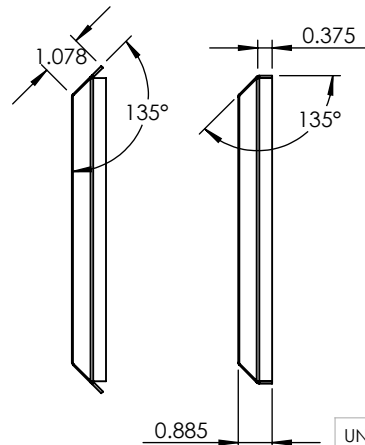
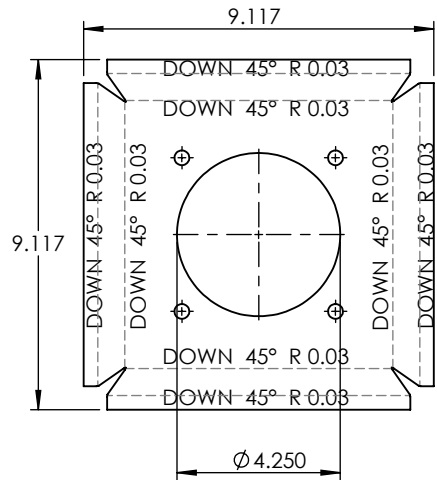

UNLESS OTHERWISE SPECIFIED:

DIMENSIONS ARE IN INCHES
TOLERANCES:
FRACTIONAL ±
ANGULAR: MACH ± BEND ±
TWO PLACE DECIMAL ±
THREE PLACE DECIMAL ±

INTERPRET GEOMETRIC
TOLERANCING PER:

MATERIAL

FINISH

DO NOT SCALE DRAWING

NAME

DATE

DRAWN

CHECKED

ENG APPR.

MFG APPR.

Q.A.

COMMENTS:

ALUMINUM 0.0635"

TITLE:

OR-30-42-8-L24-2-L-1-1-BK

SIZE
A

DWG. NO.

REV

SCALE: 1:5

WEIGHT:

SHEET 10 OF 12

PROPRIETARY AND CONFIDENTIAL
THE INFORMATION CONTAINED IN THIS
DRAWING IS THE SOLE PROPERTY OF
<INSERT COMPANY NAME HERE>. ANY
REPRODUCTION IN PART OR AS A WHOLE
WITHOUT THE WRITTEN PERMISSION OF
<INSERT COMPANY NAME HERE> IS
PROHIBITED.

NEXT ASSY

USED ON

APPLICATION

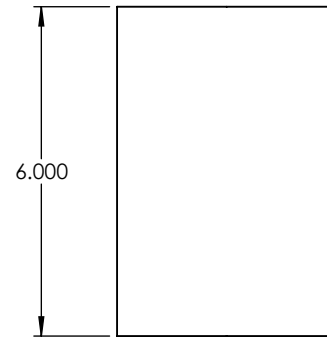
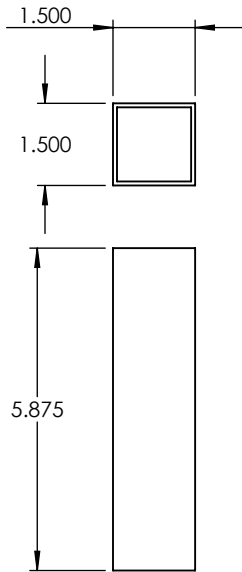
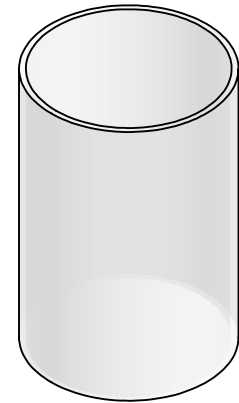
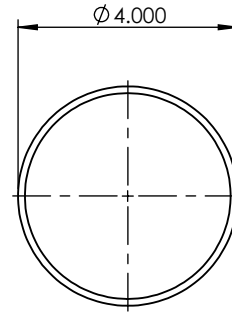
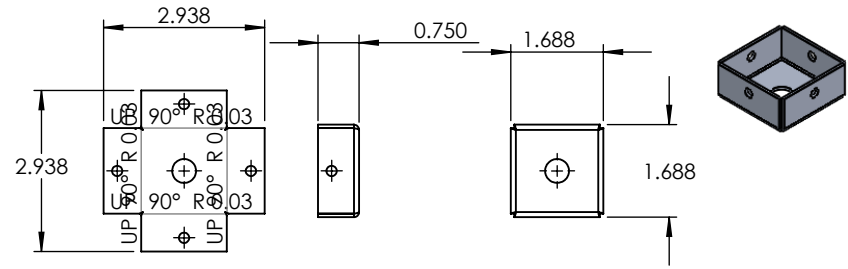
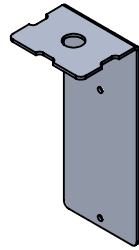
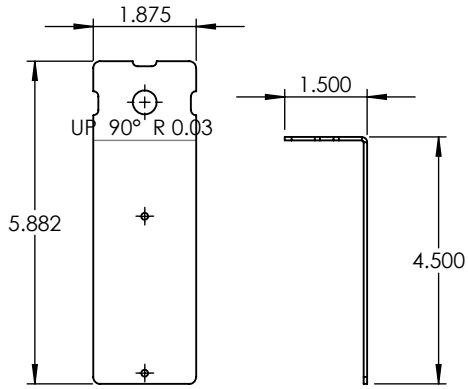

PROPRIETARY AND CONFIDENTIAL
 THE INFORMATION CONTAINED IN THIS DRAWING IS THE SOLE PROPERTY OF <INSERT COMPANY NAME HERE>. ANY REPRODUCTION IN PART OR AS A WHOLE WITHOUT THE WRITTEN PERMISSION OF <INSERT COMPANY NAME HERE> IS PROHIBITED.

		UNLESS OTHERWISE SPECIFIED:		NAME	DATE
		DIMENSIONS ARE IN INCHES	DRAWN		
		TOLERANCES:	CHECKED		
		FRACTIONAL ±	ENG APPR.		
		ANGULAR: MACH ± BEND ±	MFG APPR.		
		TWO PLACE DECIMAL ±	Q.A.		
		THREE PLACE DECIMAL ±	COMMENTS:		
		INTERPRET GEOMETRIC TOLERANCING PER:			
		MATERIAL			
NEXT ASSY	USED ON	FINISH			
APPLICATION		DO NOT SCALE DRAWING			

ALUMINUM 0.0635"		
TITLE:		
OR-30-42-8-L24-2-L-1-1-BK		
SIZE	DWG. NO.	REV
A		
SCALE: 1:3.5		WEIGHT:
		SHEET 11 OF 12

ITEM NO.	PART NUMBER	DESCRIPTION	QTY.
1	OR-30-42-8-L24-2-L-1-1-BK-SPUN LENS CAP	SPUN ALUMINUM 0.080"	1

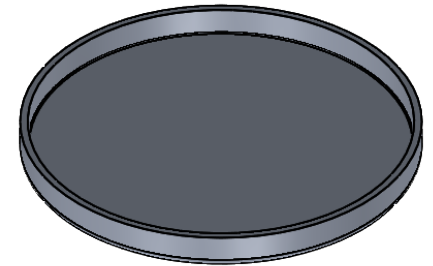
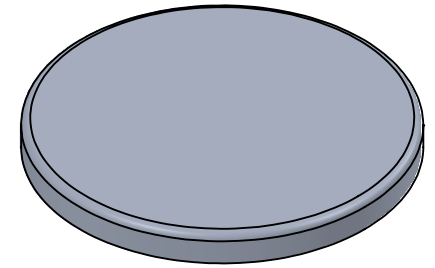
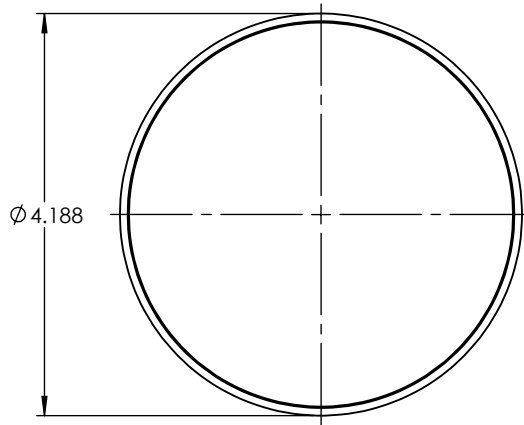
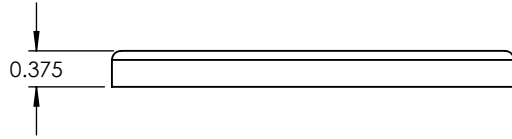

PROPRIETARY AND CONFIDENTIAL

THE INFORMATION CONTAINED IN THIS DRAWING IS THE SOLE PROPERTY OF <INSERT COMPANY NAME HERE>. ANY REPRODUCTION IN PART OR AS A WHOLE WITHOUT THE WRITTEN PERMISSION OF <INSERT COMPANY NAME HERE> IS PROHIBITED.

		UNLESS OTHERWISE SPECIFIED:		NAME	DATE	SPUN ALUMINUM 0.080"	
		DIMENSIONS ARE IN INCHES TOLERANCES: FRACTIONAL ± ANGULAR: MACH ± BEND ± TWO PLACE DECIMAL ± THREE PLACE DECIMAL ±	DRAWN			TITLE:	
		INTERPRET GEOMETRIC TOLERANCING PER:	CHECKED			OR-30-42-8-L24-2-L-1-1-BK	
		MATERIAL	ENG APPR.			SIZE	DWG. NO.
		FINISH	MFG APPR.			A	
NEXT ASSY	USED ON		Q.A.				REV
APPLICATION		DO NOT SCALE DRAWING	COMMENTS:			SCALE: 1:2	WEIGHT:
							SHEET 12 OF 12

5

4

3

2

1