

ITEM NO.	PART NUMBER	DESCRIPTION	QTY.	CUT
1	INV-WTR-U10WD58W-MN-A-TBL-WET-41K-FRAME TOP PLATE	ALUMINUM 0.125" PLATE	1	
2	INV-WTR-U10WD58W-MN-A-TBL-WET-41K-BACKPLATE	ALUMINUM 0.0635"	1	
3	INV-WTR-U10WD58W-MN-A-TBL-WET-41K-FIREPLATE	ALUMINUM 0.0635"	1	
4	INV-WTR-U10WD58W-MN-A-TBL-WET-41K-FRAME	ALUMINUM .0635"	1	
5	INV-WTR-U10WD58W-MN-A-TBL-WET-41K-END CAP	ALUMINUM 0.0635"	2	
6	INV-WTR-U10WD58W-MN-A-TBL-WET-41K-DOWN LED BRACKET	ALUMINUM 0.0635"	1	
7	INV-WTR-U10WD58W-MN-A-TBL-WET-41K-UP LED BRACKET	ALUMINUM 0.0635"	1	
8	INV-WTR-U10WD58W-MN-A-TBL-WET-41K-FRAME TABS	25 GAUGE	4	
9	INV-WTR-U10WD58W-MN-A-TBL-WET-41K-ACRYLIC	ACRYLIC	2	
10	Alfa LED PN1019 SHIM PLATE	ALUMINUM 0.125" PLATE	6	
11	ESPEN VEL29070MVH-1	DRIVER	3	
12	Espen VEL19070MVH-1	DRIVER	1	
13	Alfa LED PN1019_RevC	LED	6	
14	AlfaLED_PN1010_RevD	LED	2	

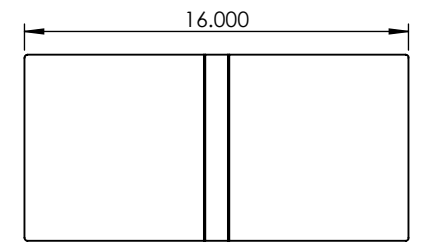
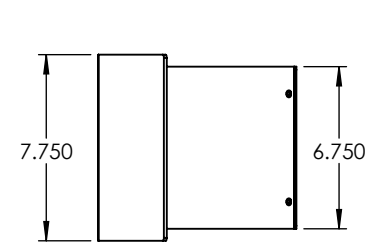
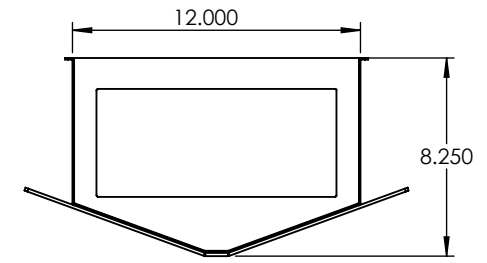
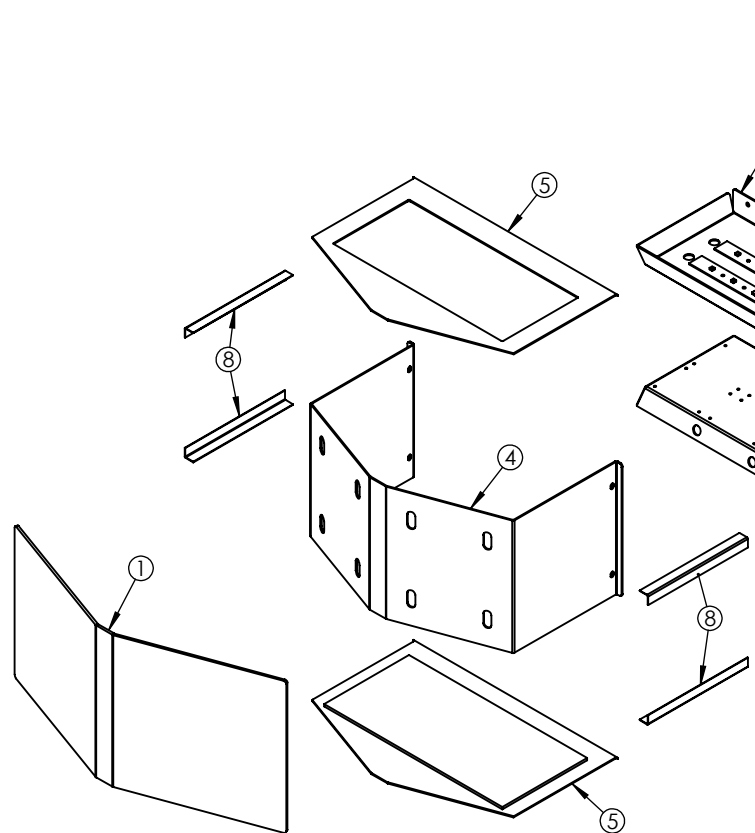
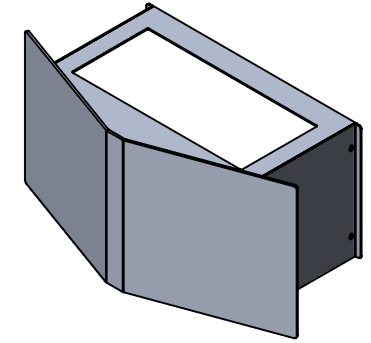
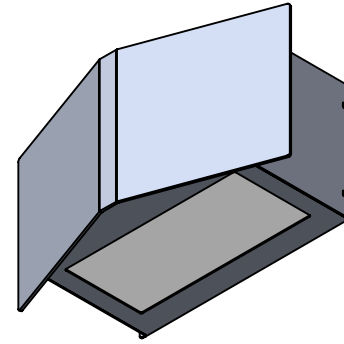

UNLESS OTHERWISE SPECIFIED:
 DIMENSIONS ARE IN INCHES
 TOLERANCES:
 FRACTIONAL ± .003
 ANGULAR: MACH ± .01 BEND ±
 TWO PLACE DECIMAL ±
 THREE PLACE DECIMAL ±.001

INTERPRET GEOMETRIC TOLERANCING PER:
 MATERIAL
 FINISH

APPLICATION DO NOT SCALE DRAWING

	NAME	DATE
DRAWN		
CHECKED		
ENG APPR.		
MFG APPR.		
Q.A.		
COMMENTS:		

TITLE:		
INV-WTR-U10WD58W-MN-A-TBL-WET-41K		
SIZE	DWG. NO.	REV
A	TICKET 25866	
SCALE: 1:8	WEIGHT:	SHEET 1 OF 7



5

4

3

2

1

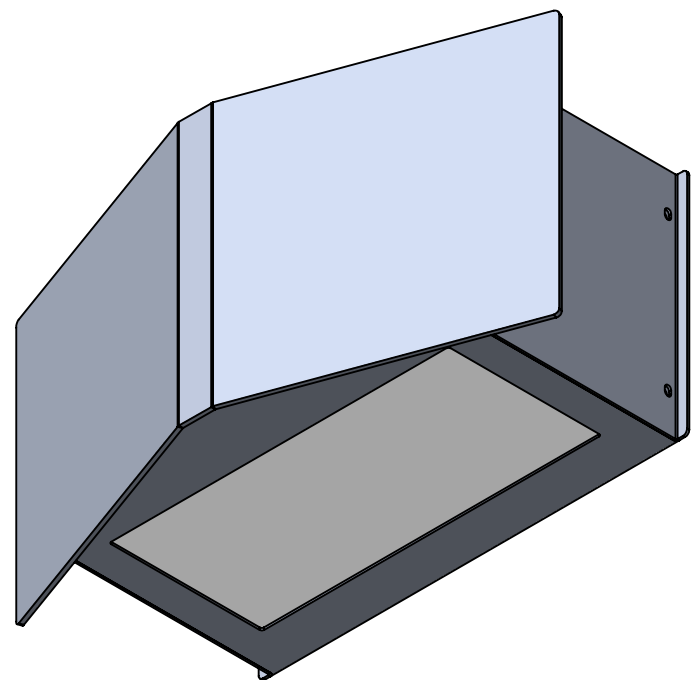
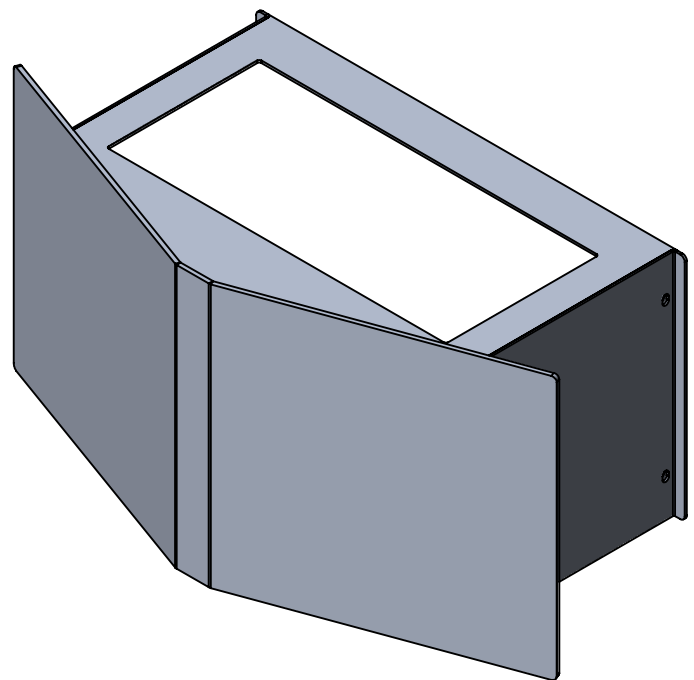
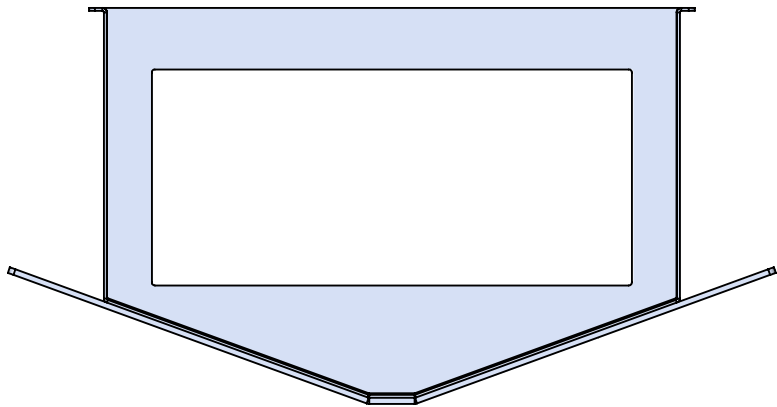

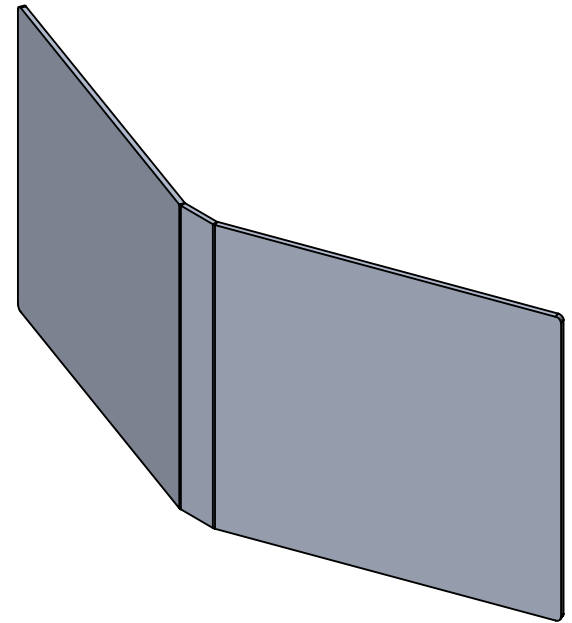
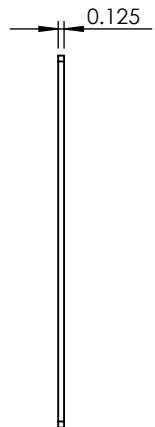
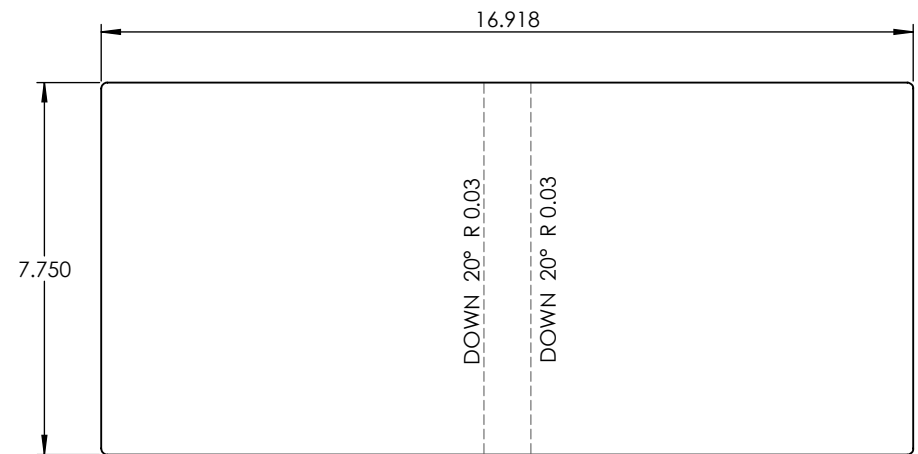
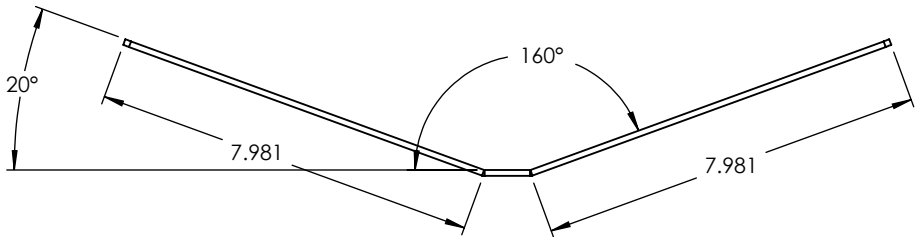

PROPRIETARY AND CONFIDENTIAL
 THE INFORMATION CONTAINED IN THIS DRAWING IS THE SOLE PROPERTY OF <INSERT COMPANY NAME HERE>. ANY REPRODUCTION IN PART OR AS A WHOLE WITHOUT THE WRITTEN PERMISSION OF <INSERT COMPANY NAME HERE> IS PROHIBITED.

		UNLESS OTHERWISE SPECIFIED:		NAME	DATE
		DIMENSIONS ARE IN INCHES	DRAWN		
		TOLERANCES:	CHECKED		
		FRACTIONAL ±	ENG APPR.		
		ANGULAR: MACH ± BEND ±	MFG APPR.		
		TWO PLACE DECIMAL ±	Q.A.		
		THREE PLACE DECIMAL ±	COMMENTS:		
		INTERPRET GEOMETRIC TOLERANCING PER:			
		MATERIAL			
NEXT ASSY	USED ON	FINISH			
APPLICATION		DO NOT SCALE DRAWING			

ALUMINUM 0.250" PLATE		
TITLE:		
INV-WTR-U10WD58W-MN-A-TBL-WET-41K		
SIZE	DWG. NO.	REV
A		
SCALE: 1:4	WEIGHT:	SHEET 3 OF 7

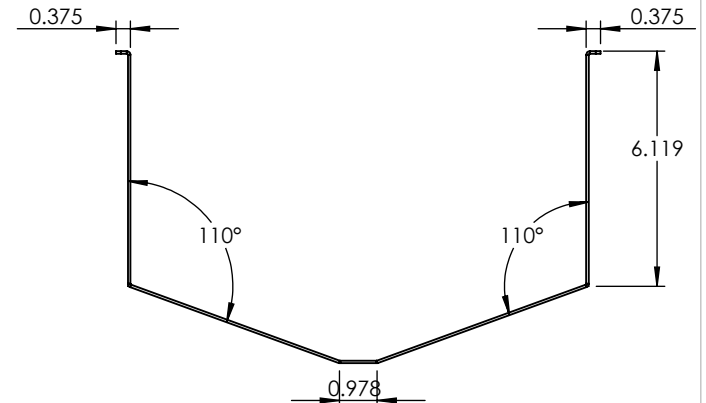
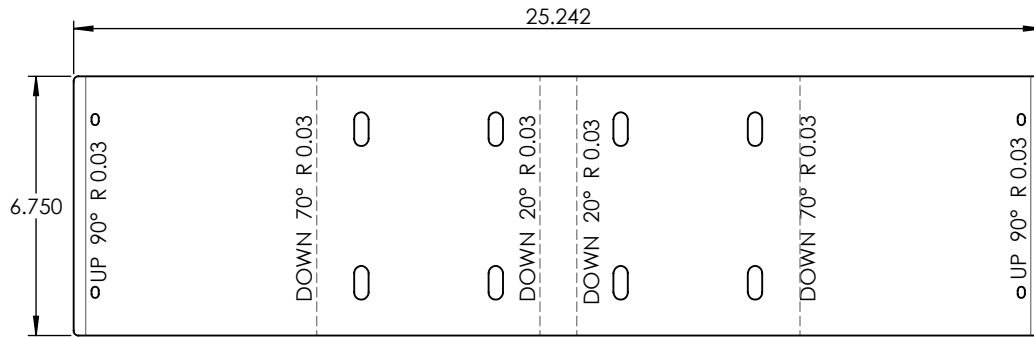
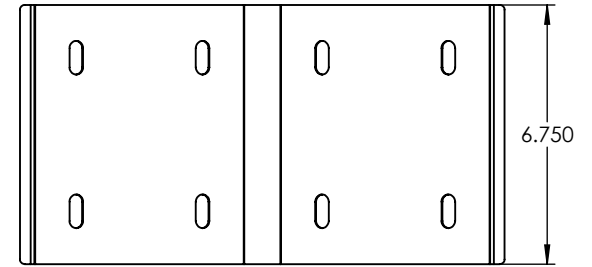
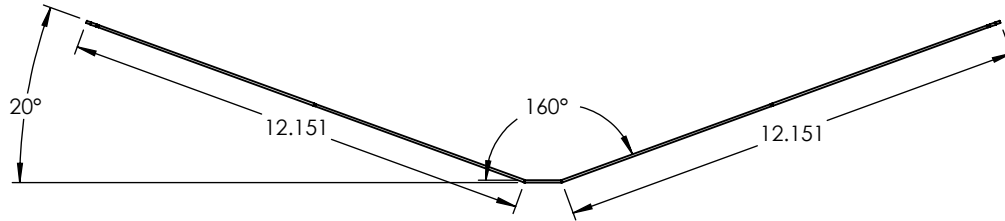
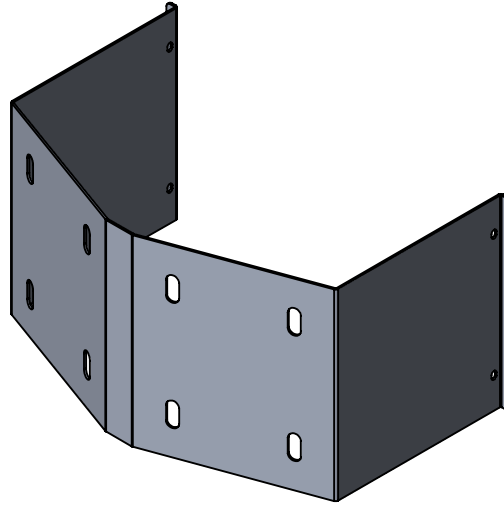
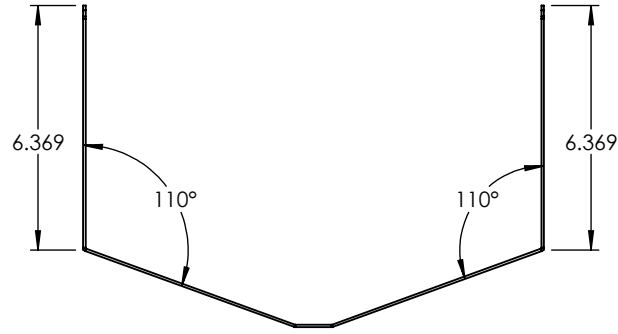

PROPRIETARY AND CONFIDENTIAL
 THE INFORMATION CONTAINED IN THIS DRAWING IS THE SOLE PROPERTY OF <INSERT COMPANY NAME HERE>. ANY REPRODUCTION IN PART OR AS A WHOLE WITHOUT THE WRITTEN PERMISSION OF <INSERT COMPANY NAME HERE> IS PROHIBITED.

		UNLESS OTHERWISE SPECIFIED:	NAME	DATE
		DIMENSIONS ARE IN INCHES	DRAWN	
		TOLERANCES:	CHECKED	
		FRACTIONAL ±	ENG APPR.	
		ANGULAR: MACH ± BEND ±	MFG APPR.	
		TWO PLACE DECIMAL ±	Q.A.	
		THREE PLACE DECIMAL ±	COMMENTS:	
		INTERPRET GEOMETRIC TOLERANCING PER:		
		MATERIAL		
		FINISH		
NEXT ASSY	USED ON			
APPLICATION		DO NOT SCALE DRAWING		

ALUMINUM .0635"

TITLE:
 INV-WTR-U10WD58W-MN-A-TBL-WET-41K

SIZE	DWG. NO.	REV
A		
SCALE: 1:5	WEIGHT:	SHEET 4 OF 7

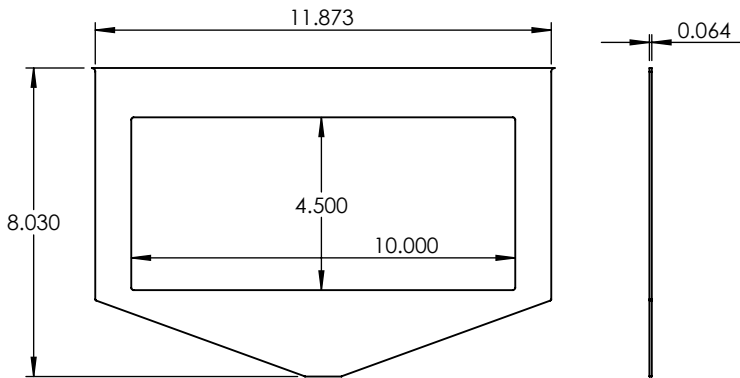
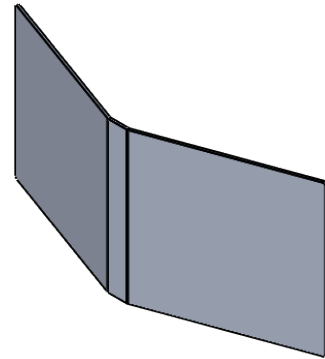
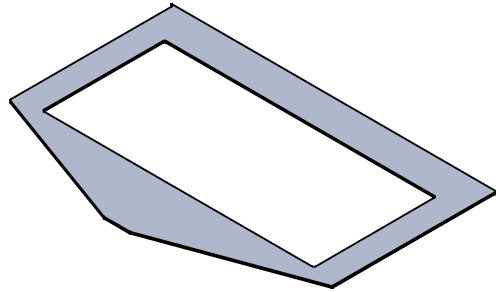
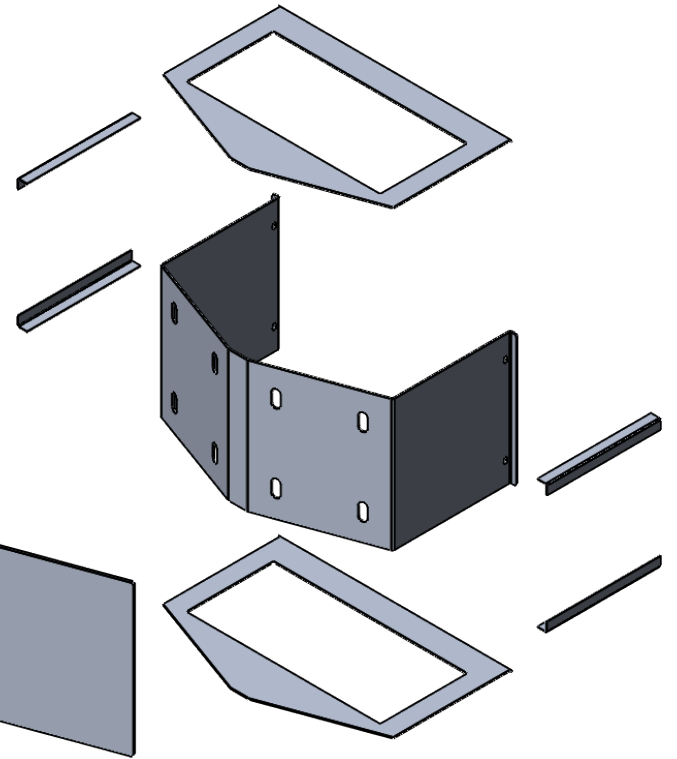
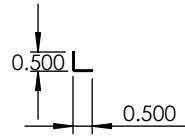
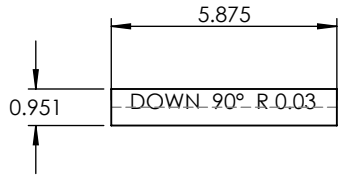

PROPRIETARY AND CONFIDENTIAL
 THE INFORMATION CONTAINED IN THIS DRAWING IS THE SOLE PROPERTY OF <INSERT COMPANY NAME HERE>. ANY REPRODUCTION IN PART OR AS A WHOLE WITHOUT THE WRITTEN PERMISSION OF <INSERT COMPANY NAME HERE> IS PROHIBITED.

		UNLESS OTHERWISE SPECIFIED:		NAME	DATE	ALUMINUM 0.0635"	
		DIMENSIONS ARE IN INCHES	DRAWN			TITLE:	
		TOLERANCES:	CHECKED			INV-WTR-U10WD58W-MN-A-TBL-WET-41K	
		FRACTIONAL ±	ENG APPR.			SIZE	DWG. NO.
		ANGULAR: MACH ± BEND ±	MFG APPR.			A	REV
		TWO PLACE DECIMAL ±	Q.A.			SCALE: 1:5	WEIGHT:
		THREE PLACE DECIMAL ±	COMMENTS:				SHEET 5 OF 7
		INTERPRET GEOMETRIC TOLERANCING PER:					
		MATERIAL					
	NEXT ASSY	FINISH					
		USED ON					
	APPLICATION	DO NOT SCALE DRAWING					

5

4

3

2

1

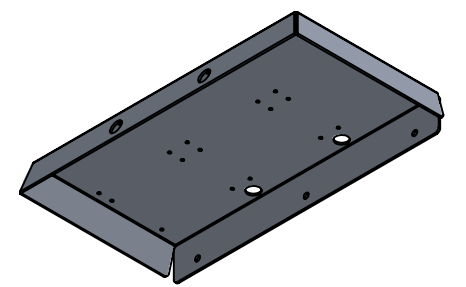
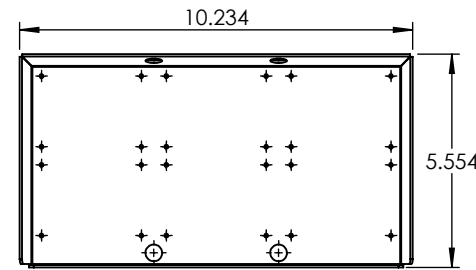
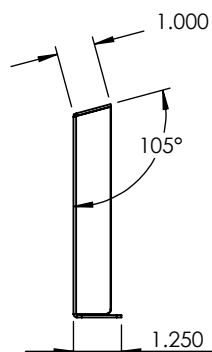
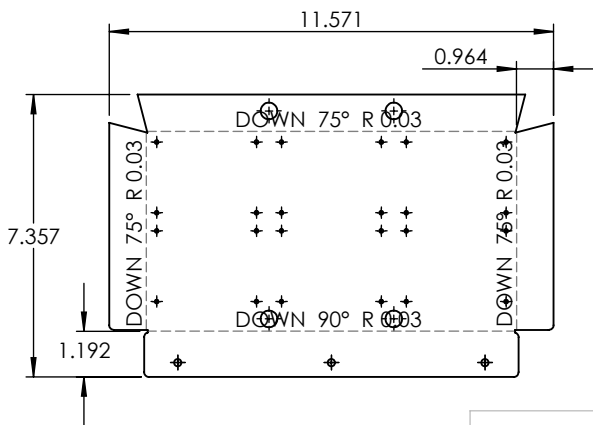
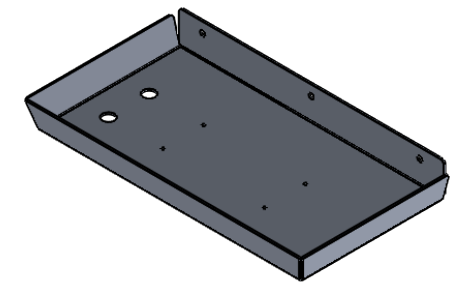
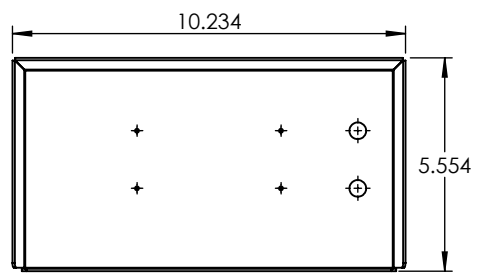
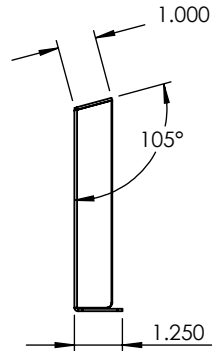
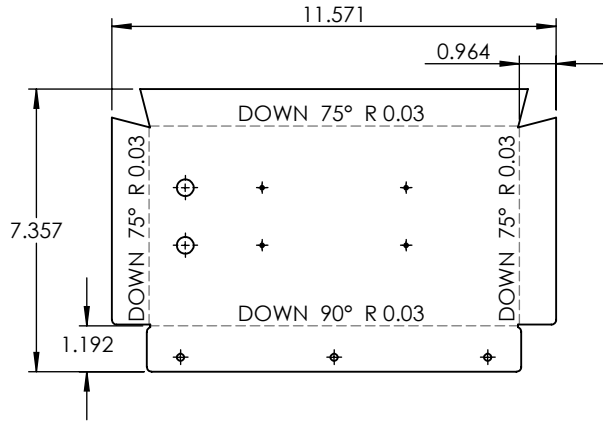

PROPRIETARY AND CONFIDENTIAL
 THE INFORMATION CONTAINED IN THIS DRAWING IS THE SOLE PROPERTY OF <INSERT COMPANY NAME HERE>. ANY REPRODUCTION IN PART OR AS A WHOLE WITHOUT THE WRITTEN PERMISSION OF <INSERT COMPANY NAME HERE> IS PROHIBITED.

		UNLESS OTHERWISE SPECIFIED:	NAME	DATE
		DIMENSIONS ARE IN INCHES	DRAWN	
		TOLERANCES:	CHECKED	
		FRACTIONAL ±	ENG APPR.	
		ANGULAR: MACH ± BEND ±	MFG APPR.	
		TWO PLACE DECIMAL ±	Q.A.	
		THREE PLACE DECIMAL ±	COMMENTS:	
		INTERPRET GEOMETRIC TOLERANCING PER:		
		MATERIAL		
		FINISH		
NEXT ASSY	USED ON			
APPLICATION	DO NOT SCALE DRAWING			

ALUMINUM 0.0635"		
TITLE:		
INV-WTR-U10WD58W-MN-A-TBL-WET-41K		
SIZE	DWG. NO.	REV
A		
SCALE: 1:5	WEIGHT:	SHEET 6 OF 7

5

4

3

2

1

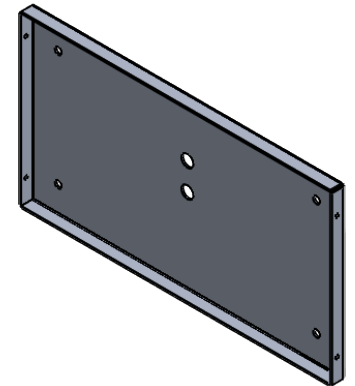
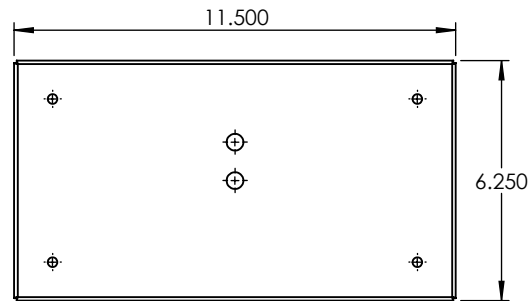
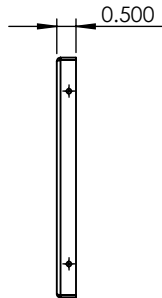
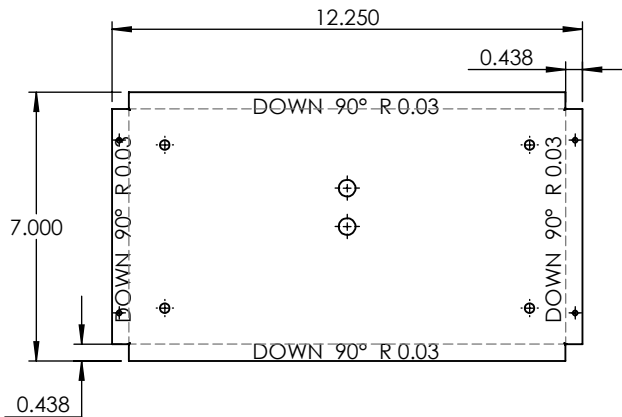
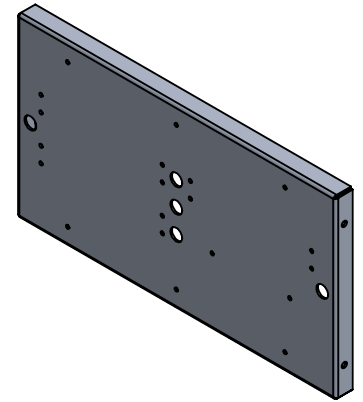
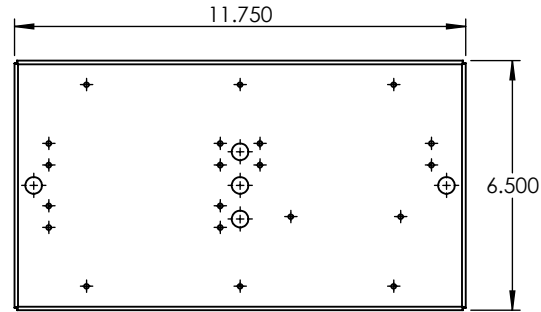
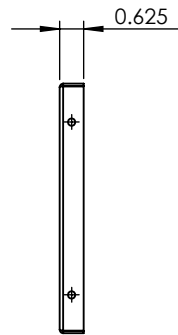
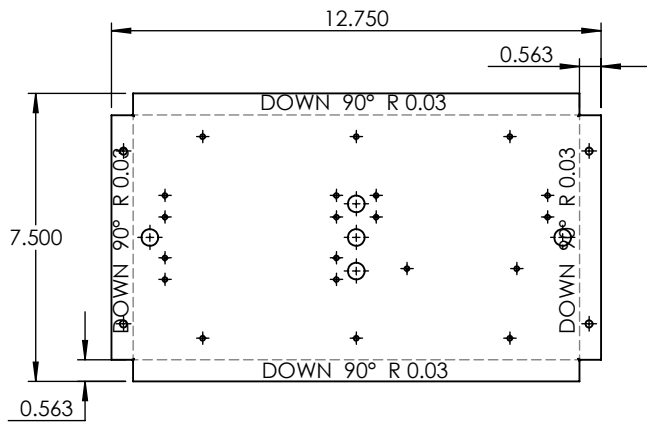

PROPRIETARY AND CONFIDENTIAL
 THE INFORMATION CONTAINED IN THIS DRAWING IS THE SOLE PROPERTY OF <INSERT COMPANY NAME HERE>. ANY REPRODUCTION IN PART OR AS A WHOLE WITHOUT THE WRITTEN PERMISSION OF <INSERT COMPANY NAME HERE> IS PROHIBITED.

		UNLESS OTHERWISE SPECIFIED:	NAME	DATE
		DIMENSIONS ARE IN INCHES	DRAWN	
		TOLERANCES:	CHECKED	
		FRACTIONAL ±	ENG APPR.	
		ANGULAR: MACH ± BEND ±	MFG APPR.	
		TWO PLACE DECIMAL ±	Q.A.	
		THREE PLACE DECIMAL ±	COMMENTS:	
		INTERPRET GEOMETRIC TOLERANCING PER:		
		MATERIAL		
		FINISH		
NEXT ASSY	USED ON			
APPLICATION	DO NOT SCALE DRAWING			

ALUMINUM 0.0635"

TITLE:
 INV-WTR-U10WD58W-MN-A-TBL-WET-41K

SIZE	DWG. NO.	REV
A		
SCALE: 1:5	WEIGHT:	SHEET 7 OF 7