

ITEM NO.	PART NUMBER	DESCRIPTION	QTY.	CUT
1	WH-W-48-36W-MG-WF-RTBEC-DIM-41K-BACKPLATE	22 GAUGE	1	
2	WH-W-48-36W-MG-WF-RTBEC-DIM-41K-LED SPACER	22 GAUGE	1	
3	WH-W-48-36W-MG-WF-RTBEC-DIM-41K-FIREPLATE	22 GAUGE	1	
4	WH-W-48-36W-MG-WF-RTBEC-DIM-41K-LENS RAIL	22 GAUGE	2	
5	WH-W-48-36W-MG-WF-RTBEC-DIM-41K-TOP CAP	22 GAUGE	2	
6	WH-W-48-36W-MG-WF-RTBEC-DIM-41K-SPUN CAP	SPUN ALUMINUM 0.080"	2	
7	WH-W-48-36W-MG-WF-RTBEC-DIM-41K-ALUMINUM BAR	1/2" SQUARE ALUMINUM BAR	1	
8	WH-W-48-36W-MG-WF-RTBEC-DIM-41K-ACRYLIC	ACRYLIC	1	
9	DS-15W-350C1542010-3001	DRIVER	1	
10	KTLD-25-UV-700-VDIM-LA1	DRIVER	1	
11	AifaLED PN110B RevC	LED	3	

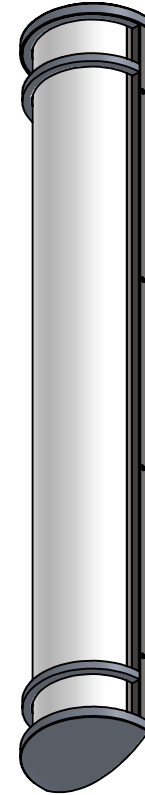
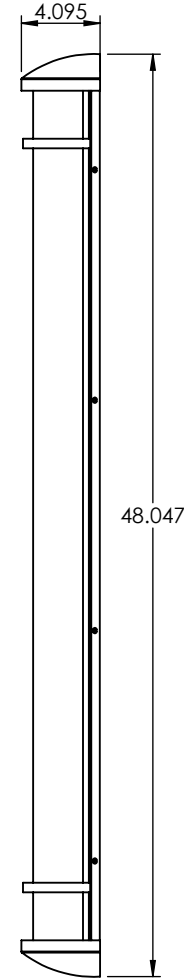
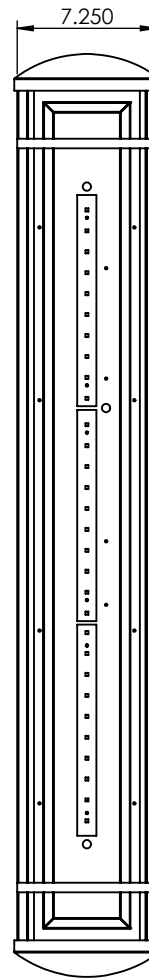
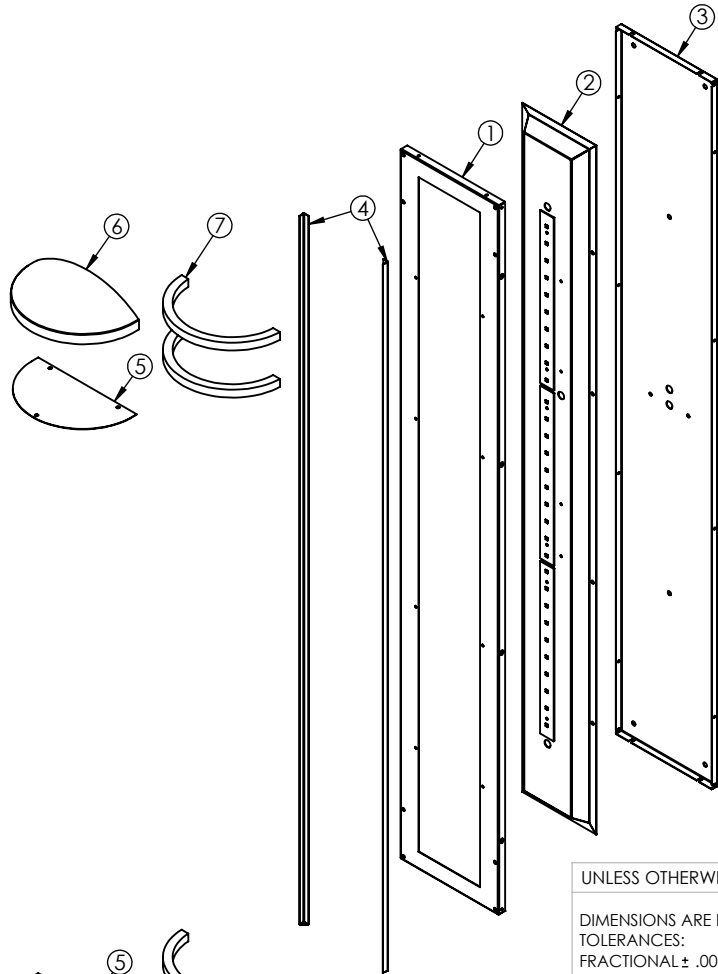

EVERGREEN LIGHTING

ALL BEND RADIUS .030"

APPLICATION

DO NOT SCALE DRAWING

UNLESS OTHERWISE SPECIFIED:

DIMENSIONS ARE IN INCHES
 TOLERANCES:
 FRACTIONAL ± .003
 ANGULAR: MACH ± .01 BEND ±
 TWO PLACE DECIMAL ±
 THREE PLACE DECIMAL ± .001

INTERPRET GEOMETRIC
 TOLERANCING PER:

MATERIAL

FINISH

NAME

DATE

DRAWN

CHECKED

ENG APPR.

MFG APPR.

Q.A.

COMMENTS:

TITLE:

WH-W-48-36W-MG-WF-RTBEC-DIM-41K

SIZE DWG. NO.

A TICKET 25879

REV

SCALE: 1:10 WEIGHT:

SHEET 1 OF 9

5

4

3

2

1

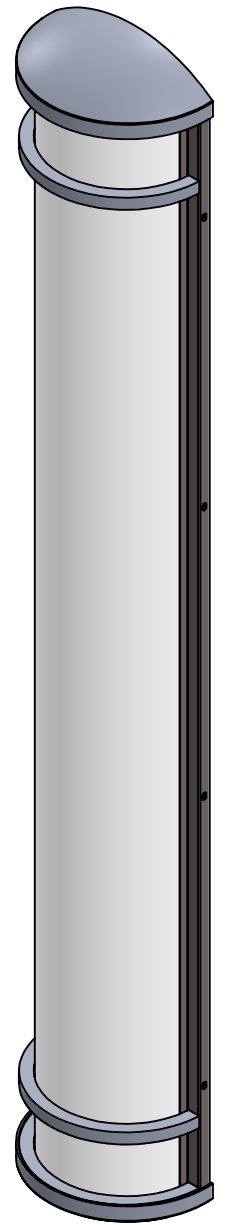
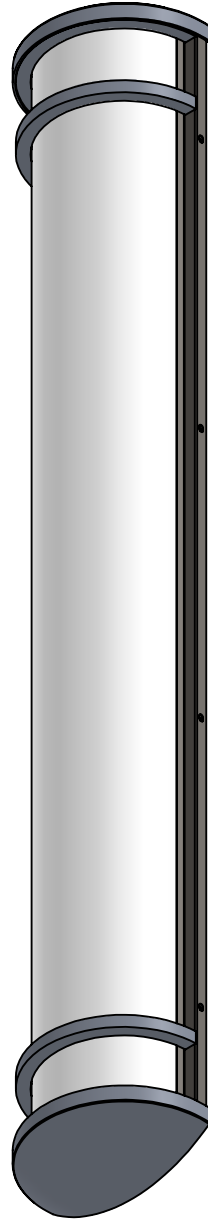
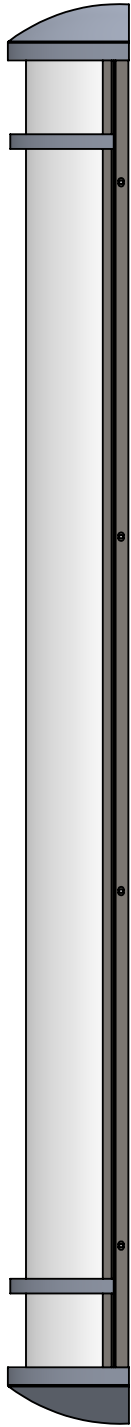
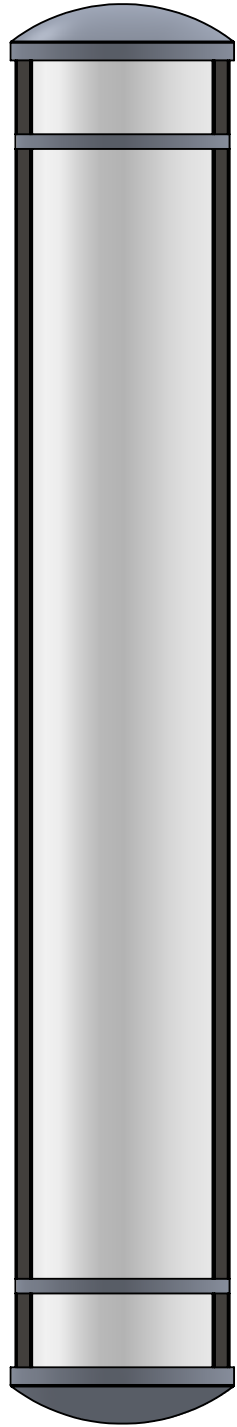

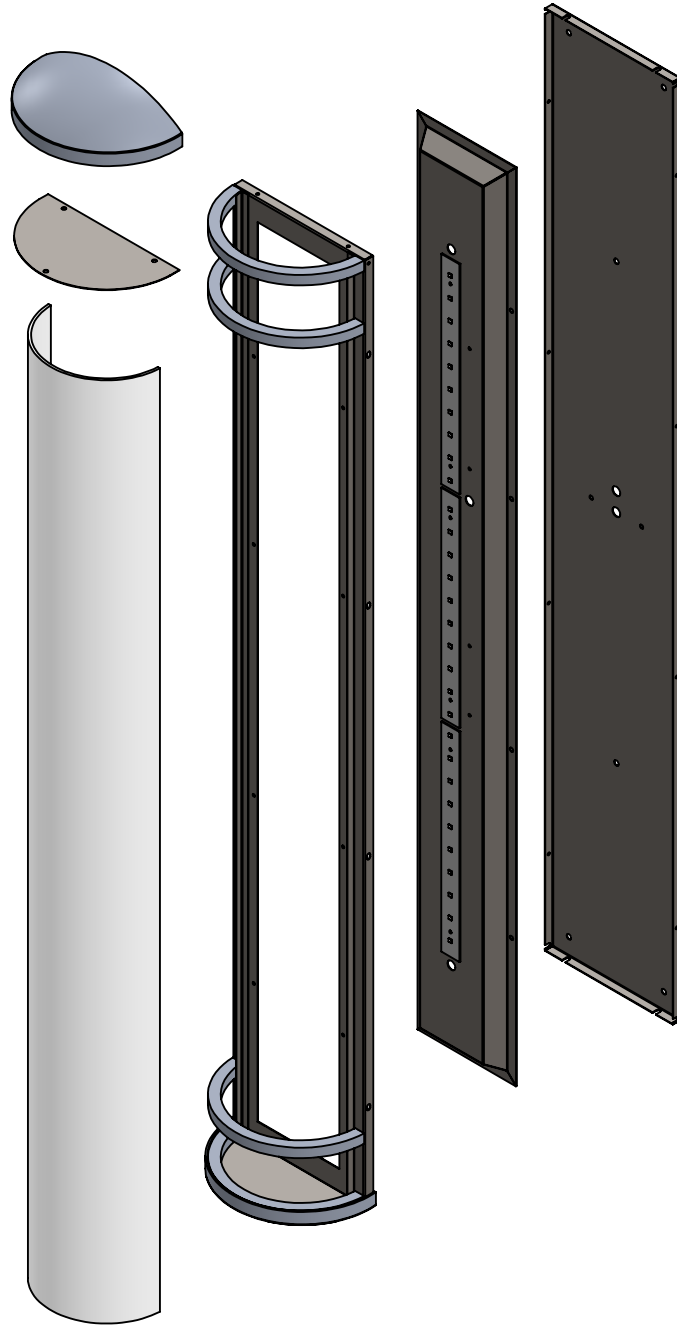

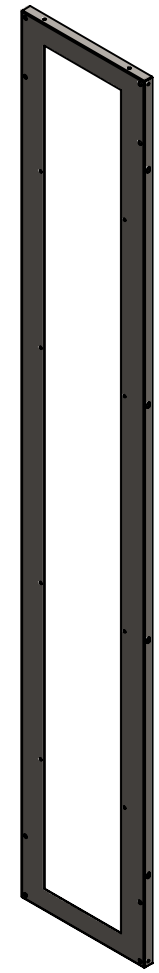
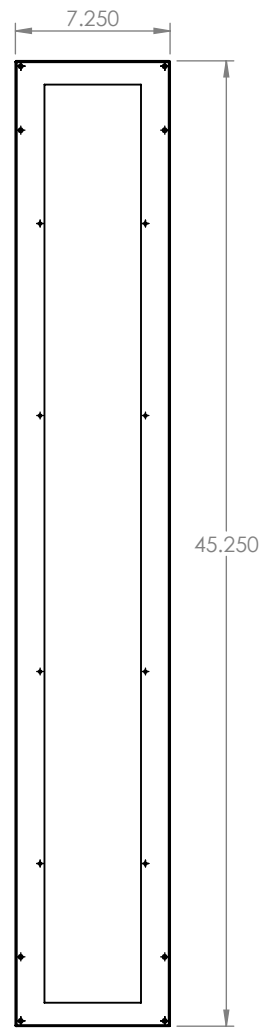
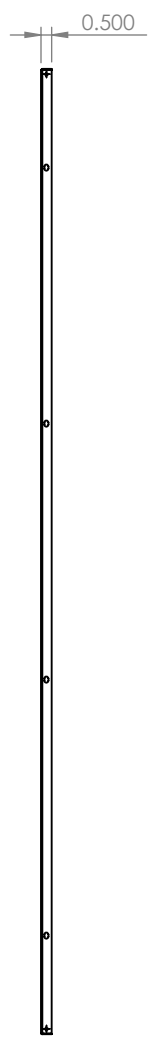
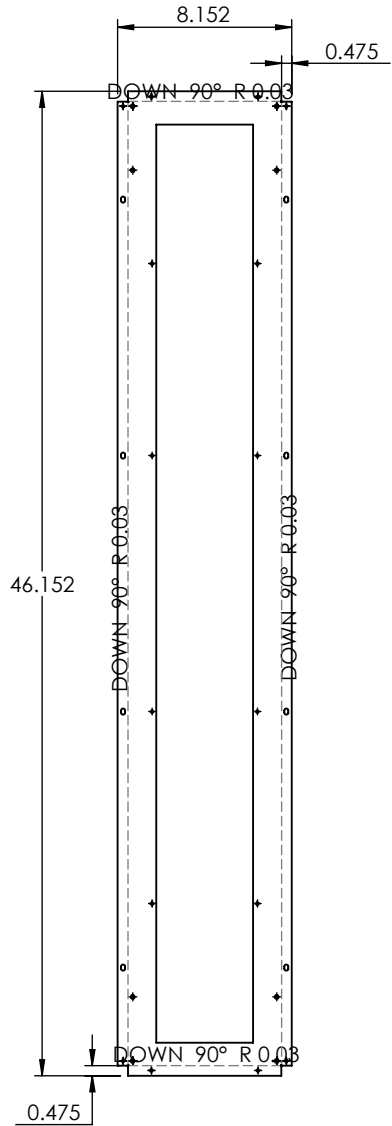

PROPRIETARY AND CONFIDENTIAL
 THE INFORMATION CONTAINED IN THIS DRAWING IS THE SOLE PROPERTY OF <INSERT COMPANY NAME HERE>. ANY REPRODUCTION IN PART OR AS A WHOLE WITHOUT THE WRITTEN PERMISSION OF <INSERT COMPANY NAME HERE> IS PROHIBITED.

BACKPLATE

		UNLESS OTHERWISE SPECIFIED: DIMENSIONS ARE IN INCHES TOLERANCES: FRACTIONAL ± ANGULAR: MACH ± BEND ± TWO PLACE DECIMAL ± THREE PLACE DECIMAL ±	NAME	DATE	22 GAUGE	
			TITLE:		WH-W-48-36W-MG-WF-RTBEC-DIM-41K	
		INTERPRET GEOMETRIC TOLERANCING PER: MATERIAL	DRAWN		SIZE	DWG. NO.
			CHECKED			
		FINISH	ENG APPR.		SCALE: 1:9	
			APPLICATION	MFG APPR.		WEIGHT:
NEXT ASSY	USED ON	DO NOT SCALE DRAWING		Q.A.		SHEET 4 OF 9
				COMMENTS:		

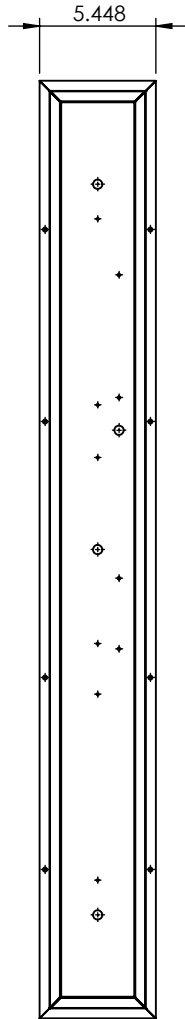
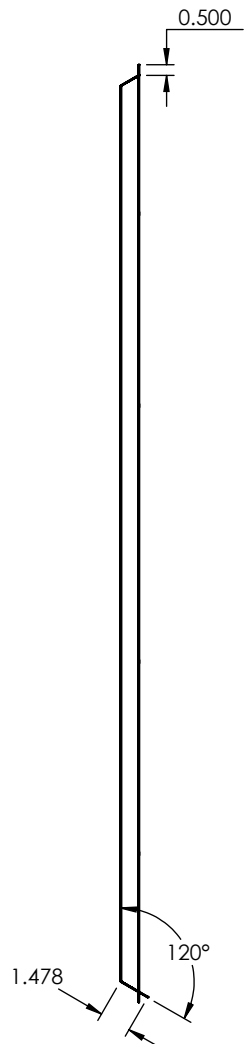
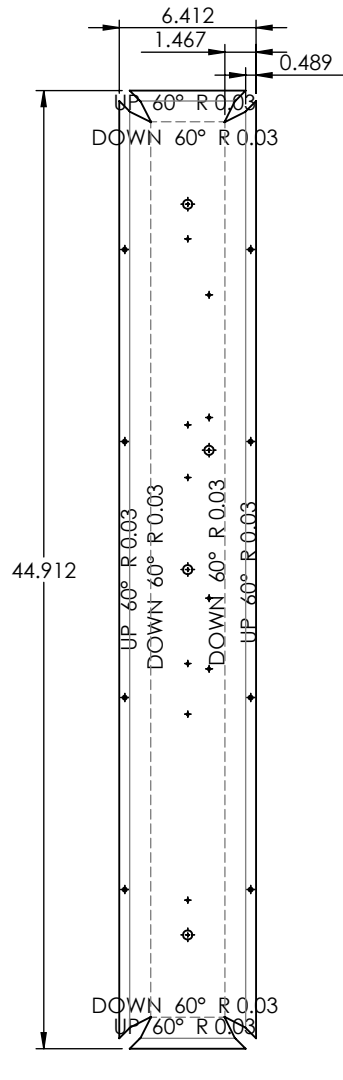

PROPRIETARY AND CONFIDENTIAL
 THE INFORMATION CONTAINED IN THIS DRAWING IS THE SOLE PROPERTY OF <INSERT COMPANY NAME HERE>. ANY REPRODUCTION IN PART OR AS A WHOLE WITHOUT THE WRITTEN PERMISSION OF <INSERT COMPANY NAME HERE> IS PROHIBITED.

BACKPLATE		UNLESS OTHERWISE SPECIFIED:		NAME	DATE	22 GAUGE	
		DIMENSIONS ARE IN INCHES TOLERANCES: FRACTIONAL ± ANGULAR: MACH ± BEND ± TWO PLACE DECIMAL ± THREE PLACE DECIMAL ±		DRAWN		TITLE:	
		INTERPRET GEOMETRIC TOLERANCING PER:		CHECKED		WH-W-48-36W-MG-WF-RTBEC-DIM-41K	
		MATERIAL		ENG APPR.		SIZE DWG. NO. REV	
NEXT ASSY	USED ON	FINISH		MFG APPR.		A	
APPLICATION		DO NOT SCALE DRAWING		Q.A.		SCALE: 1:9 WEIGHT: SHEET 5 OF 9	
				COMMENTS:			

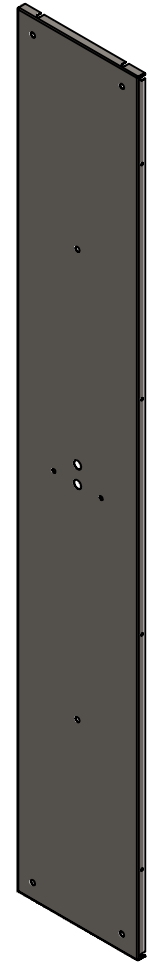
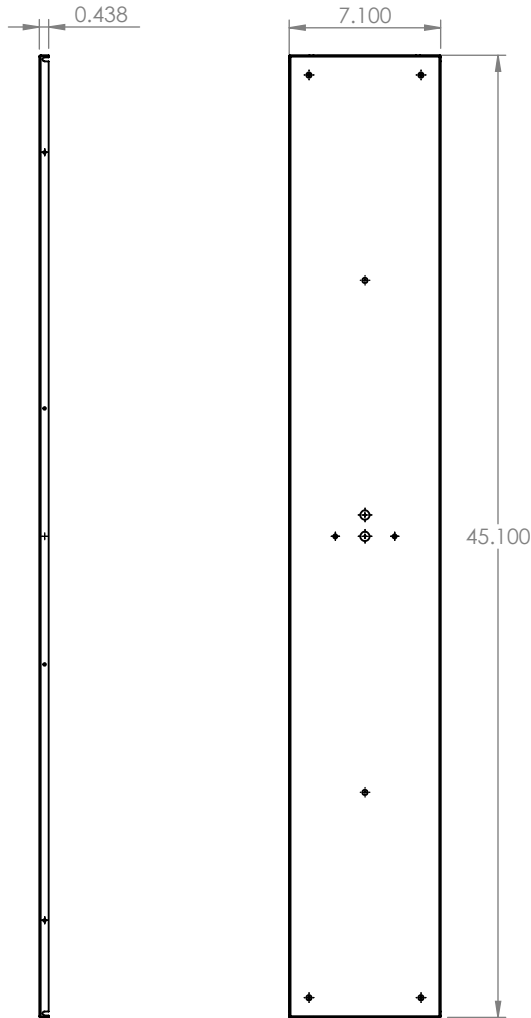
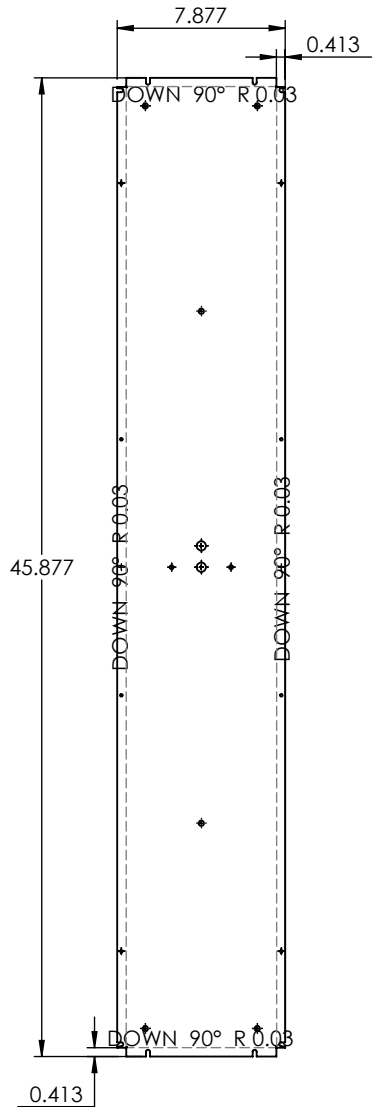

PROPRIETARY AND CONFIDENTIAL
 THE INFORMATION CONTAINED IN THIS DRAWING IS THE SOLE PROPERTY OF <INSERT COMPANY NAME HERE>. ANY REPRODUCTION IN PART OR AS A WHOLE WITHOUT THE WRITTEN PERMISSION OF <INSERT COMPANY NAME HERE> IS PROHIBITED.

FIREPLATE		UNLESS OTHERWISE SPECIFIED:	NAME	DATE	22 GAUGE	
		DIMENSIONS ARE IN INCHES	DRAWN		TITLE:	
		TOLERANCES:	CHECKED		WH-W-48-36W-MG-WF-RTBEC-DIM-41K	
		FRACTIONAL ±	ENG APPR.		SIZE DWG. NO. REV	
		ANGULAR: MACH ± BEND ±	MFG APPR.		SCALE: 1:9 WEIGHT: SHEET 6 OF 9	
		TWO PLACE DECIMAL ±	Q.A.			
		THREE PLACE DECIMAL ±	COMMENTS:			
		INTERPRET GEOMETRIC TOLERANCING PER:				
		MATERIAL				
NEXT ASSY	USED ON	FINISH				
APPLICATION		DO NOT SCALE DRAWING				

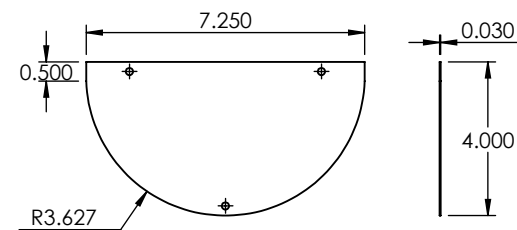
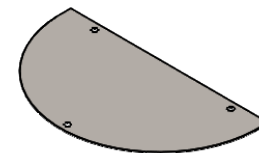
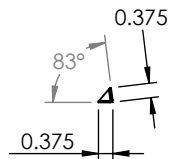
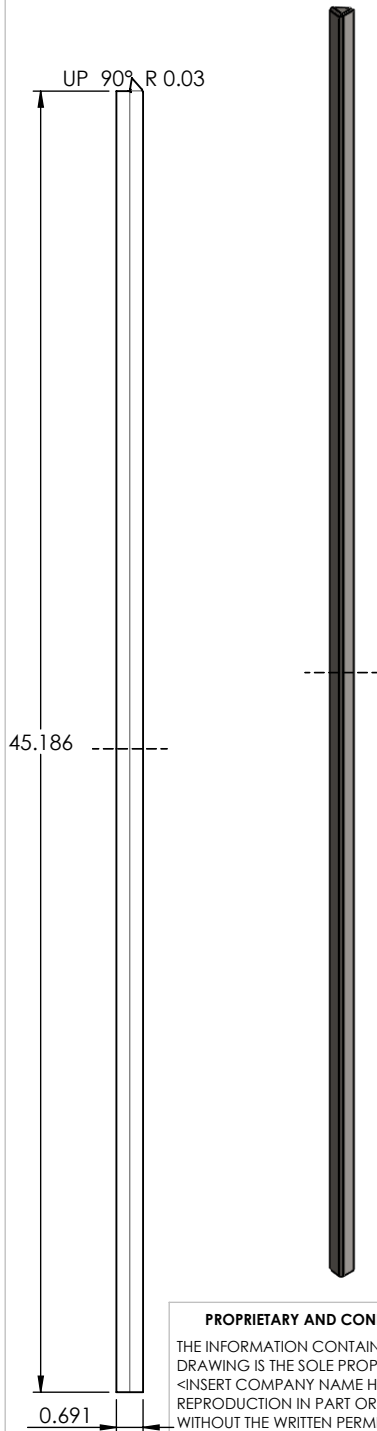

TOP CAP

LENS RAIL

PROPRIETARY AND CONFIDENTIAL
 THE INFORMATION CONTAINED IN THIS DRAWING IS THE SOLE PROPERTY OF <INSERT COMPANY NAME HERE>. ANY REPRODUCTION IN PART OR AS A WHOLE WITHOUT THE WRITTEN PERMISSION OF <INSERT COMPANY NAME HERE> IS PROHIBITED.

		UNLESS OTHERWISE SPECIFIED:	NAME	DATE	22 GAUGE	
		DIMENSIONS ARE IN INCHES	DRAWN		TITLE:	
		TOLERANCES:	CHECKED		WH-W-48-36W-MG-WF-RTBEC-DIM-41K	
		FRACTIONAL ±	ENG APPR.		SIZE	DWG. NO.
		ANGULAR: MACH ± BEND ±	MFG APPR.		A	REV
		TWO PLACE DECIMAL ±	Q.A.		SCALE: 1:5	
		THREE PLACE DECIMAL ±	COMMENTS:		WEIGHT:	SHEET 7 OF 9
NEXT ASSY	USED ON	INTERPRET GEOMETRIC TOLERANCING PER:				
APPLICATION		MATERIAL				
		FINISH				
		DO NOT SCALE DRAWING				

5

4

3

2

1

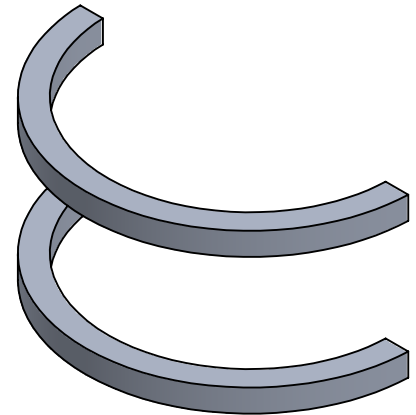
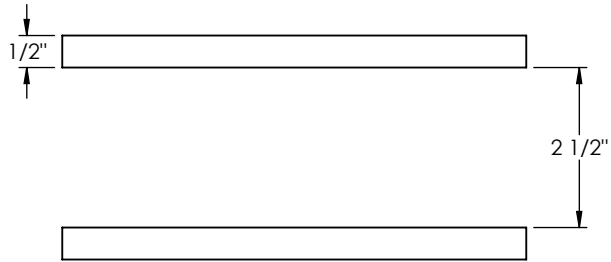
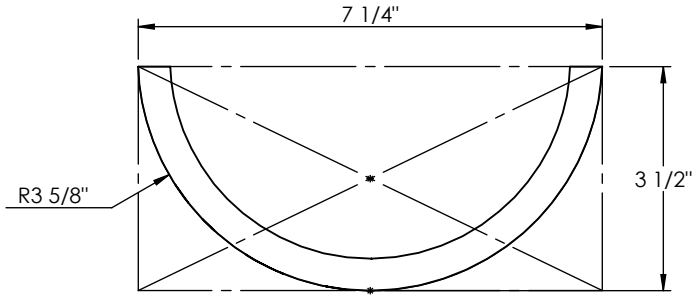
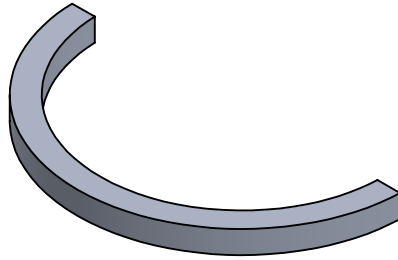

UNLESS OTHERWISE SPECIFIED:		NAME	DATE	1/2" SQUARE ALUMINUM BAR	
DIMENSIONS ARE IN INCHES TOLERANCES: FRACTIONAL ± ANGULAR: MACH ± BEND ± TWO PLACE DECIMAL ± THREE PLACE DECIMAL ±		DRAWN			
INTERPRET GEOMETRIC TOLERANCING PER:		CHECKED		WH-W-48-36W-MG-WF-RTBEC-DIM-41K	
		ENG APPR.			
		MFG APPR.			
MATERIAL		Q.A.		REV	
FINISH		COMMENTS:		SIZE	DWG. NO.
DO NOT SCALE DRAWING				A	
APPLICATION				SCALE: 1:3	WEIGHT:
				SHEET 8 OF 9	

PROPRIETARY AND CONFIDENTIAL
THE INFORMATION CONTAINED IN THIS DRAWING IS THE SOLE PROPERTY OF <INSERT COMPANY NAME HERE>. ANY REPRODUCTION IN PART OR AS A WHOLE WITHOUT THE WRITTEN PERMISSION OF <INSERT COMPANY NAME HERE> IS PROHIBITED.

ITEM NO.	PART NUMBER	DESCRIPTION	QTY.
1	WH-W-48-36W-MG-WF-RTBEC-DIM-41K-SPUN CAP	SPUN ALUMINUM 0.080"	1

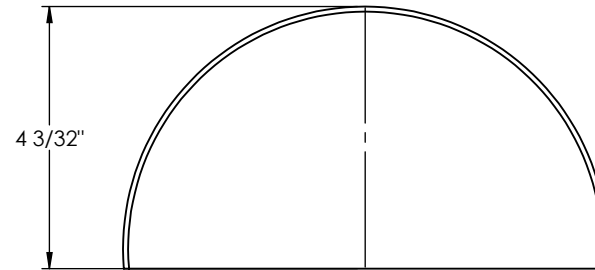
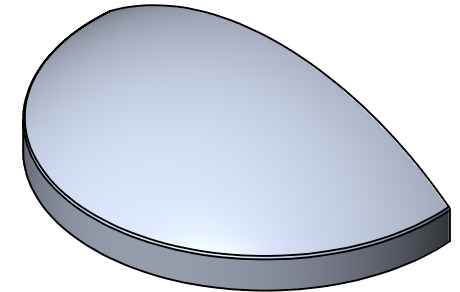
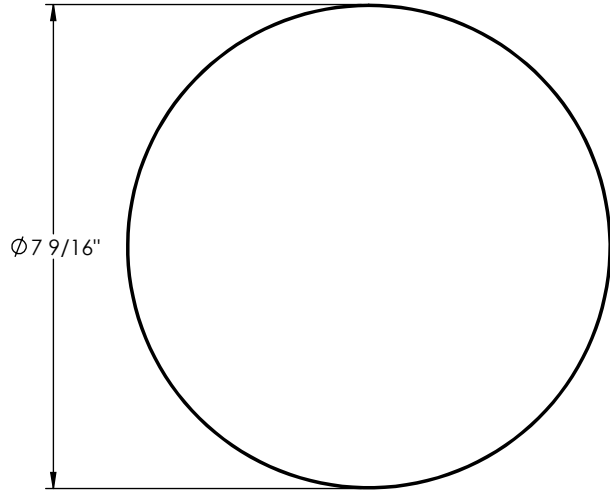
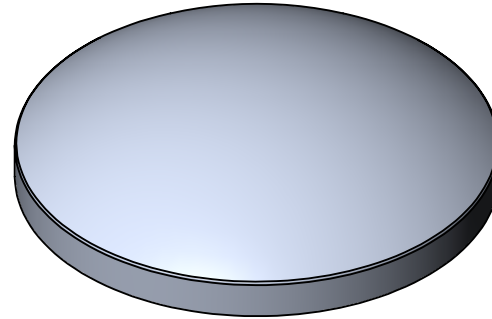
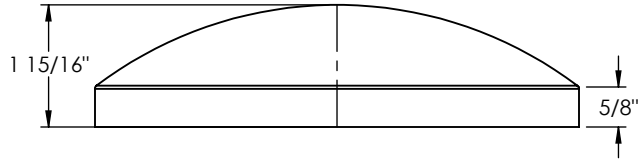

PROPRIETARY AND CONFIDENTIAL
 THE INFORMATION CONTAINED IN THIS DRAWING IS THE SOLE PROPERTY OF <INSERT COMPANY NAME HERE>. ANY REPRODUCTION IN PART OR AS A WHOLE WITHOUT THE WRITTEN PERMISSION OF <INSERT COMPANY NAME HERE> IS PROHIBITED.

		UNLESS OTHERWISE SPECIFIED:	NAME	DATE	SPUN ALUMINUM 0.080"	
		DIMENSIONS ARE IN INCHES	DRAWN		TITLE:	
		TOLERANCES:	CHECKED		WH-W-48-36W-MG-WF-RTBEC-DIM-41K	
		FRACTIONAL ±	ENG APPR.		SIZE DWG. NO. REV	
		ANGULAR: MACH ± BEND ±	MFG APPR.		A	
		TWO PLACE DECIMAL ±	Q.A.		SCALE: 1:3 WEIGHT: SHEET 9 OF 9	
		THREE PLACE DECIMAL ±	COMMENTS:			
		INTERPRET GEOMETRIC TOLERANCING PER:				
		MATERIAL				
		FINISH				
NEXT ASSY	USED ON	APPLICATION	DO NOT SCALE DRAWING			

5

4

3

2

1