

ITEM NO.	PART NUMBER	DESCRIPTION	QTY.	CUT
1	CANOPY	SPUN 18 GAUGE	1	
2	SWIVEL	SWIVEL	1	
3	SWIVEL BRACKET	SWIVEL BRACKET	1	
4	MET-S-23-36W-MW-WF-35K-SUPPORT BACKPLATE	22 GAUGE	1	
5	MET-S-23-36W-MW-WF-35K-SUPPORT FIREPLATE	22 GAUGE	1	
6	MET-S-23-36W-MW-WF-35K-DRIVER BRACKET	22 GAUGE	1	
7	MET-S-23-36W-MW-WF-35K-SUPPORT CROSS BOTTOM	18 GAUGE	1	
8	MET-S-23-36W-MW-WF-35K-SUPPORT CROSS TOP	18 GAUGE	1	
10	MET-S-23-36W-MW-WF-35K-ALUMINUM BAR	1/2" SQR ALUMINUM BAR	1	
11	MET-S-23-36W-MW-WF-35K-CONNECTING TUBE 0.875"	7/8" ROUND ALUMINUM TUBE	1	
12	MET-S-23-36W-MW-WF-35K-ACRYLIC BOWL	ACRYLIC	1	
13	.375 BRASS BALL	3/8" BRASS BALL	2	
14	KTLD-25-UV-700-VDIM-LA1	DRIVER	2	
15	Airtailed_PN110B_RevC	LED	4	

UNLESS OTHERWISE SPECIFIED:

DIMENSIONS ARE IN INCHES
 TOLERANCES:
 FRACTIONAL ± .003
 ANGULAR: MACH ± .01 BEND ±
 TWO PLACE DECIMAL ±
 THREE PLACE DECIMAL ±.001

INTERPRET GEOMETRIC
 TOLERANCING PER:

MATERIAL

FINISH

ALL BEND RADIUS .030"

APPLICATION

DO NOT SCALE DRAWING

NAME DATE

DRAWN
 CHECKED
 ENG APPR.
 MFG APPR.

Q.A.

COMMENTS:

TITLE:

MET-S-23-36W-MW-WF-35K

SIZE DWG. NO.

REV

A TICKET 25881

SCALE: 1:10 WEIGHT:

SHEET 1 OF 7



EVERGREEN LIGHTING

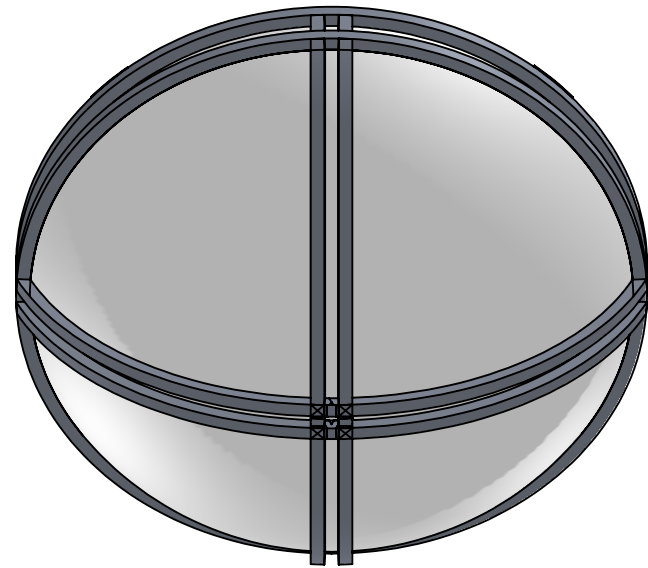
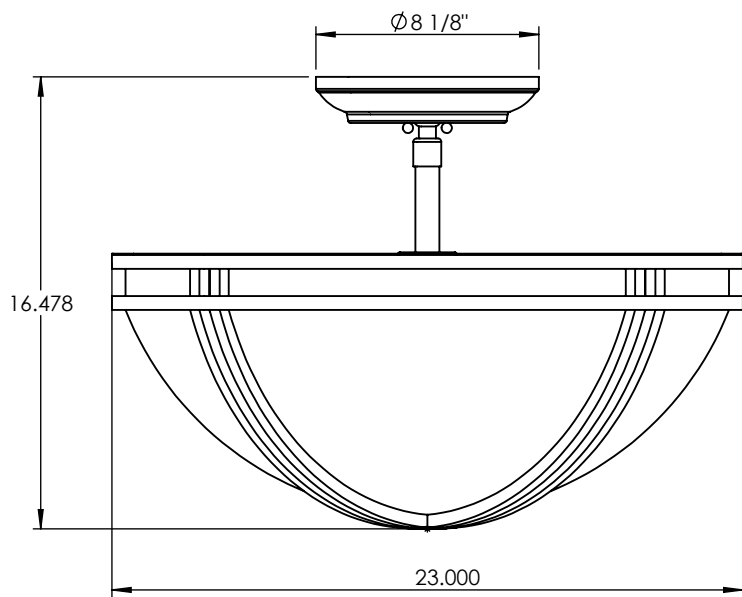
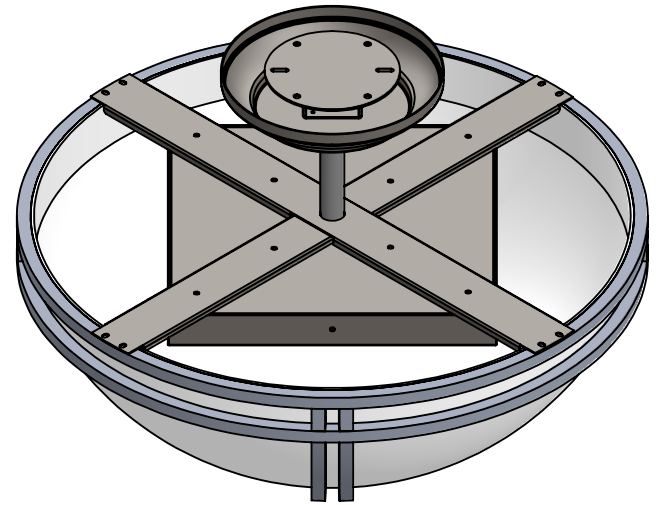
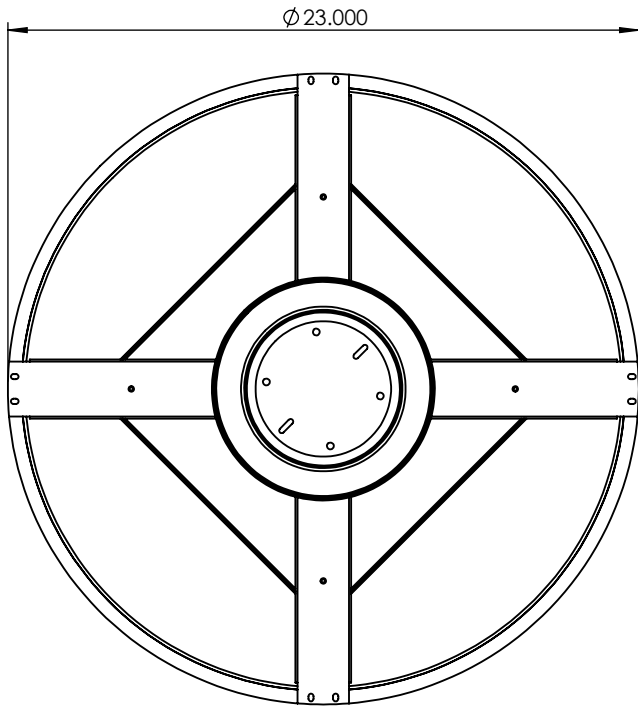

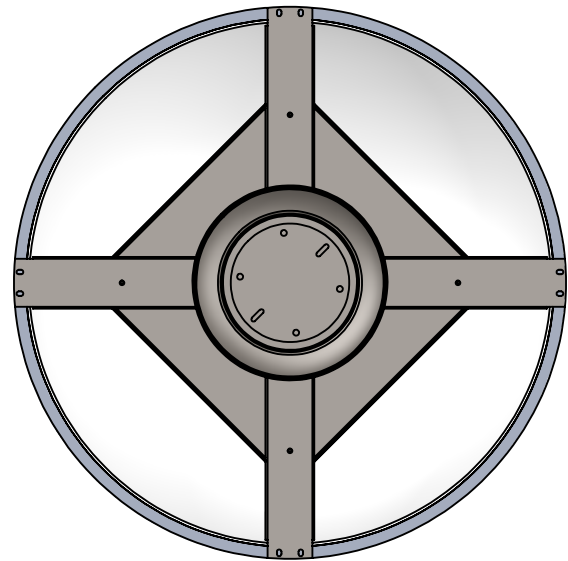
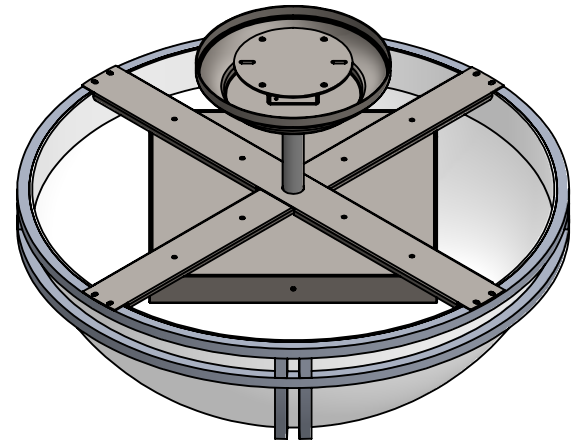
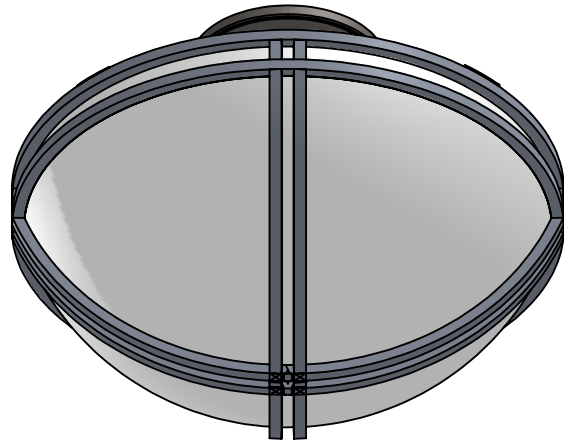
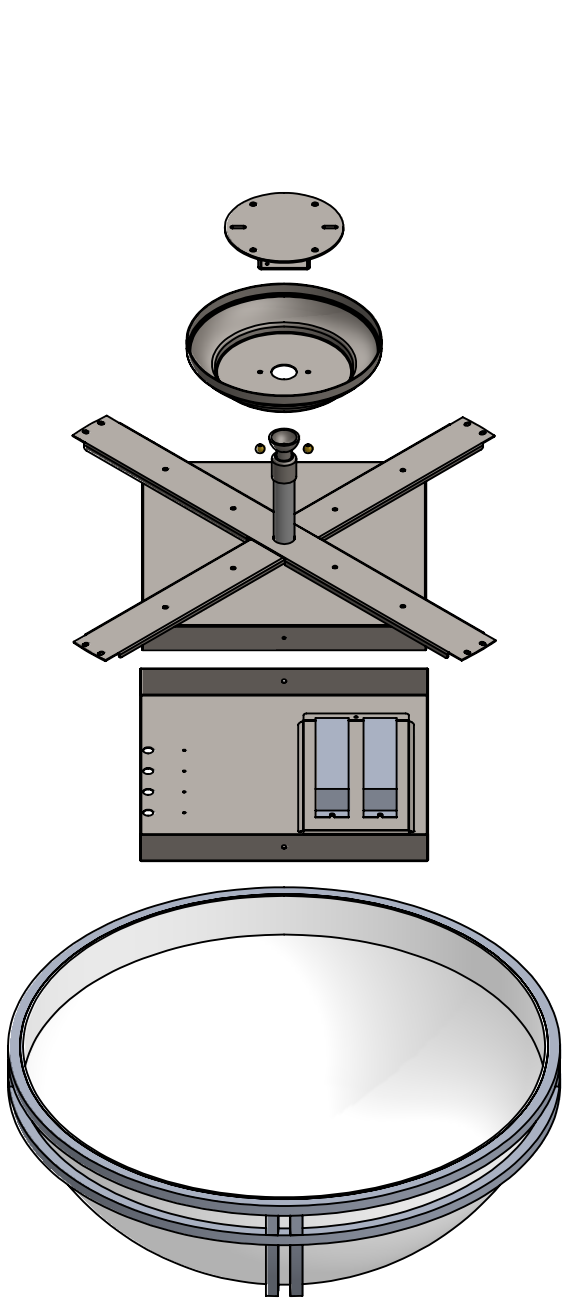

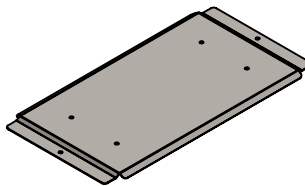
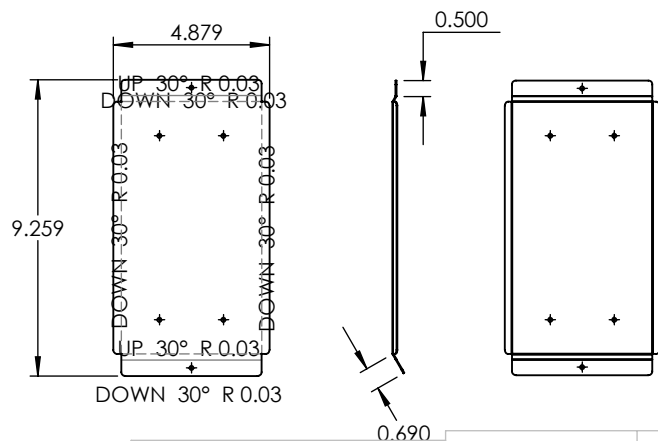
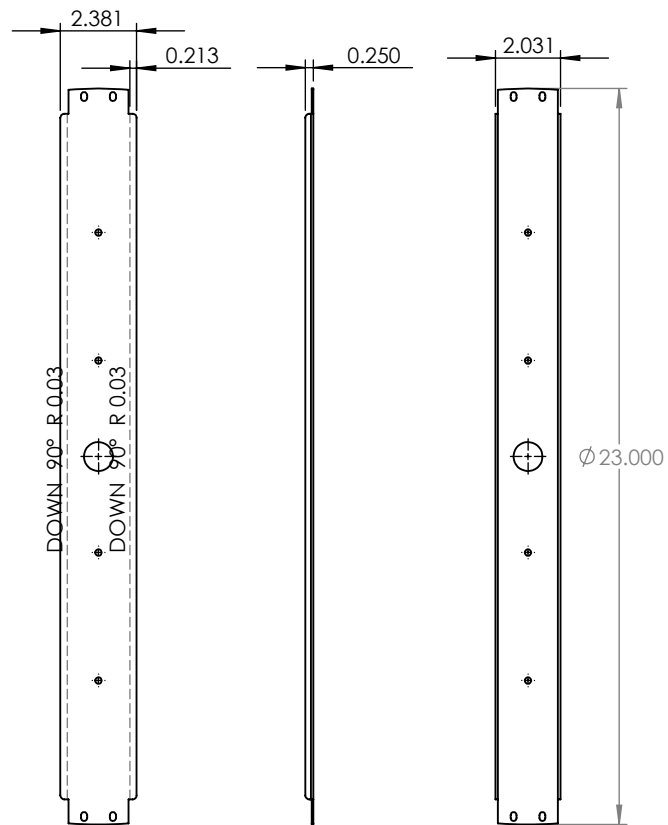
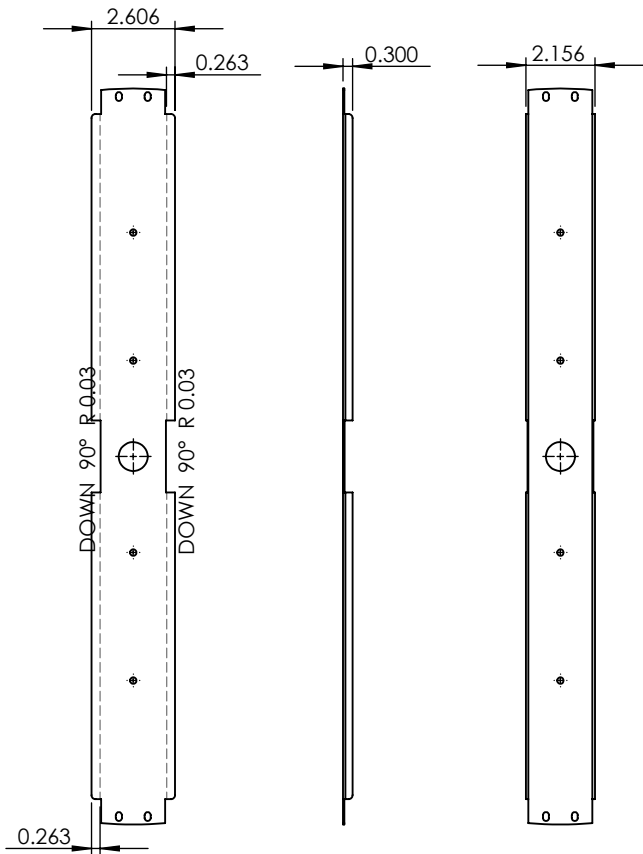

PROPRIETARY AND CONFIDENTIAL
 THE INFORMATION CONTAINED IN THIS DRAWING IS THE SOLE PROPERTY OF <INSERT COMPANY NAME HERE>. ANY REPRODUCTION IN PART OR AS A WHOLE WITHOUT THE WRITTEN PERMISSION OF <INSERT COMPANY NAME HERE> IS PROHIBITED.

		INTERPRET GEOMETRIC TOLERANCING PER:
		MATERIAL
		FINISH
NEXT ASSY	USED ON	
APPLICATION		DO NOT SCALE DRAWING

UNLESS OTHERWISE SPECIFIED:

DIMENSIONS ARE IN INCHES
 TOLERANCES:
 FRACTIONAL ±
 ANGULAR: MACH ± BEND ±
 TWO PLACE DECIMAL ±
 THREE PLACE DECIMAL ±

	NAME	DATE
DRAWN		
CHECKED		
ENG APPR.		
MFG APPR.		
Q.A.		
COMMENTS:		

18 GAUGE

TITLE:

MET-S-23-36W-MW-WF-35K

SIZE	DWG. NO.	REV
A		
SCALE: 1:6	WEIGHT:	SHEET 5 OF 7

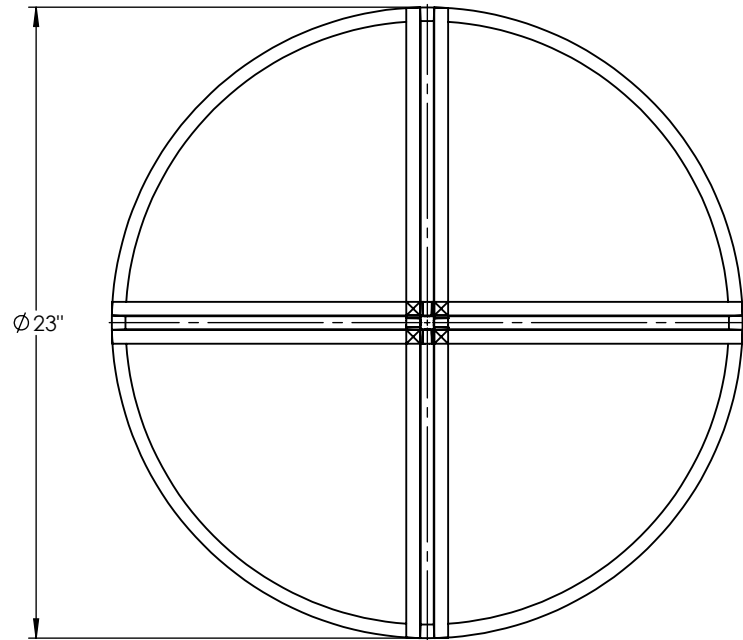
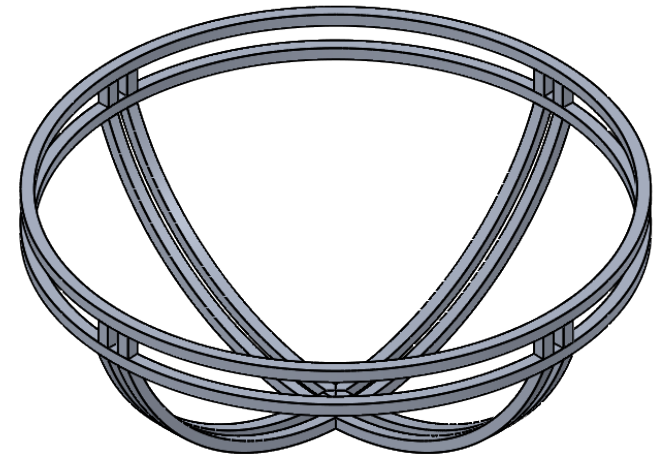
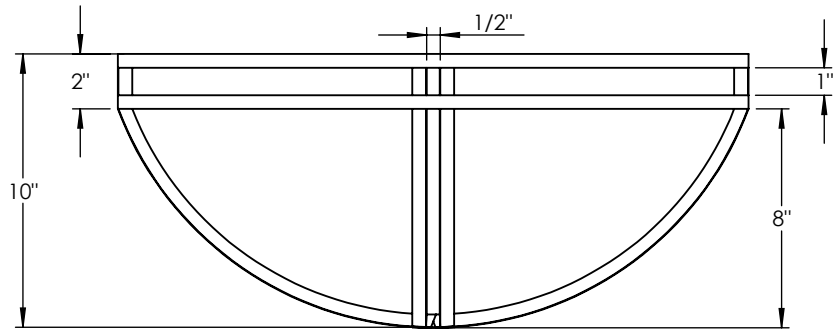

UNLESS OTHERWISE SPECIFIED:		NAME	DATE	1/2" SQR ALUMINUM BAR	
DIMENSIONS ARE IN INCHES TOLERANCES: FRACTIONAL ± ANGULAR: MACH ± BEND ± TWO PLACE DECIMAL ± THREE PLACE DECIMAL ±		DRAWN			
INTERPRET GEOMETRIC TOLERANCING PER:		CHECKED		MET-S-23-36W-MW-WF-35K	
		ENG APPR.			
MATERIAL		MFG APPR.		SIZE DWG. NO. REV	
		Q.A.		A	
FINISH		COMMENTS:		SCALE: 1:7 WEIGHT: SHEET 6 OF 7	
		DO NOT SCALE DRAWING			

PROPRIETARY AND CONFIDENTIAL
THE INFORMATION CONTAINED IN THIS DRAWING IS THE SOLE PROPERTY OF <INSERT COMPANY NAME HERE>. ANY REPRODUCTION IN PART OR AS A WHOLE WITHOUT THE WRITTEN PERMISSION OF <INSERT COMPANY NAME HERE> IS PROHIBITED.

NEXT ASSY	USED ON
APPLICATION	

ITEM NO.	PART NUMBER	DESCRIPTION	QTY.
1	APO-S-23-36W-ORB-WF-35K-CANOPY	SPUN CANOPY	1

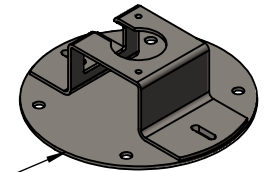
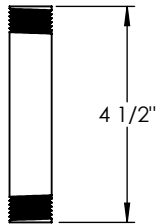
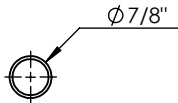
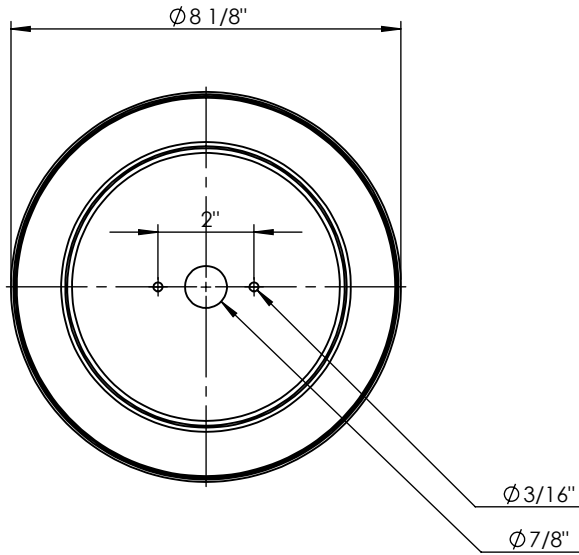
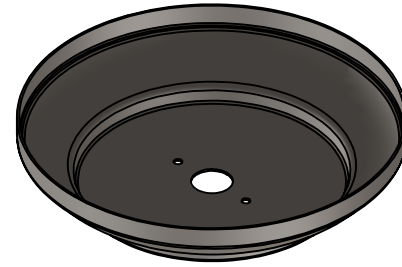
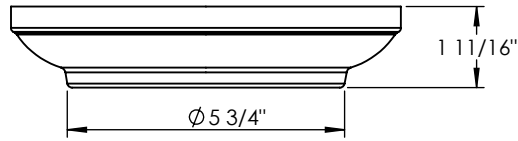

SWIVEL CANOPY, ajustar altura de spinning al soporte giratorio

PROPRIETARY AND CONFIDENTIAL
 THE INFORMATION CONTAINED IN THIS DRAWING IS THE SOLE PROPERTY OF <INSERT COMPANY NAME HERE>. ANY REPRODUCTION IN PART OR AS A WHOLE WITHOUT THE WRITTEN PERMISSION OF <INSERT COMPANY NAME HERE> IS PROHIBITED.

		UNLESS OTHERWISE SPECIFIED:	NAME	DATE	SPUN 18 GAUGE	
		DIMENSIONS ARE IN INCHES TOLERANCES: FRACTIONAL ± ANGULAR: MACH ± BEND ± TWO PLACE DECIMAL ± THREE PLACE DECIMAL ±	DRAWN			
		INTERPRET GEOMETRIC TOLERANCING PER:	CHECKED		MET-S-23-36W-MW-WF-35K	
		MATERIAL	ENG APPR.			
		FINISH	MFG APPR.		SIZE	DWG. NO.
NEXT ASSY	USED ON		Q.A.		A	REV
APPLICATION		DO NOT SCALE DRAWING	COMMENTS:		SCALE: 1:4	WEIGHT:
5	4	3	2	1	SHEET 7 OF 7	