

ITEM NO.	PART NUMBER	DESCRIPTION	QTY.	CUT
1	B30618L-AB-A-TPS-30K-FIREPLATE	.125" ALUMINUM PLATE	1	
2	B30618L-AB-A-TPS-30K-6X6 BOLLARD BODY 1	18 GAUGE	2	
3	B30618L-AB-A-TPS-30K-6X6 BOLLARD BODY 2	18 GAUGE	2	
4	B30618L-AB-A-TPS-30K-TOP BASE HAT	18 GAUGE	1	
5	B30618L-AB-A-TPS-30K-BODY RIB	18 GAUGE	2	
8	B30618L-AB-A-TPS-30K-9X9 TRIANGLE	18 GAUGE	4	
7	B30618L-AB-A-TPS-30K-HEAD BASE	18 GAUGE	1	
8	B30618L-AB-A-TPS-30K-BOTTOM RIBS	18 GAUGE	4	
9	B30618L-AB-A-TPS-30K-INNER PLATE	18 GAUGE	1	
10	B30618L-AB-A-TPS-30K-TRIANGLE FLANGE	22 GAUGE	4	
11	B30618L-AB-A-TPS-30K-MOUTING PLATE	22 GAUGE	1	
12	B30618L-AB-A-TPS-30K-DRIVER BRACKET	22 GAUGE	1	
13	B30618L-AB-A-TPS-30K-TUBE BRACKET	22 GAUGE	1	
14	B30618L-AB-A-TPS-30K-ACRYLIC	ACRYLIC	4	
15	B30618L-AB-A-TPS-30K-SQUARE TUBE	TUBE	1	
16	AilqLED PN1010 RevD	LED	4	
17	ESPFN VFL29070MVH-1	DRIVER	1	

UNLESS OTHERWISE SPECIFIED:
 DIMENSIONS ARE IN INCHES
 TOLERANCES:
 FRACTIONAL ± .003
 ANGULAR: MACH ± .01 BEND ±
 TWO PLACE DECIMAL ±
 THREE PLACE DECIMAL ±.001

INTERPRET GEOMETRIC
 TOLERANCING PER:
 MATERIAL
 FINISH

APPLICATION DO NOT SCALE DRAWING

	NAME	DATE
DRAWN		
CHECKED		
ENG APPR.		
MFG APPR.		
Q.A.		
COMMENTS:		

TITLE: B30618L-AB-A-TPS-30K		
SIZE	DWG. NO.	REV
A	TICKET 25918	
SCALE: 1:10	WEIGHT:	SHEET 1 OF 10



ALL BEND RADIUS .030"

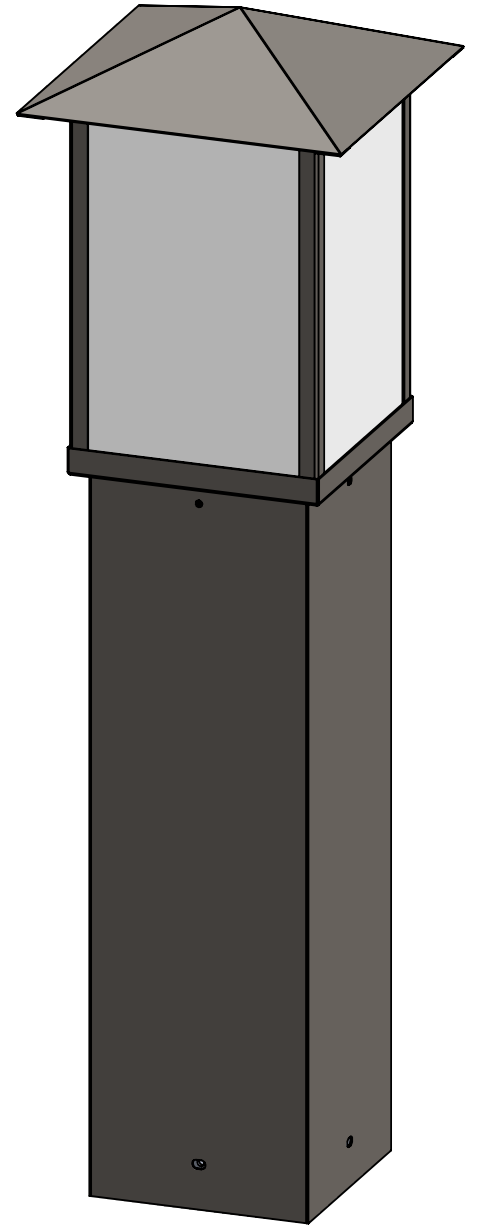
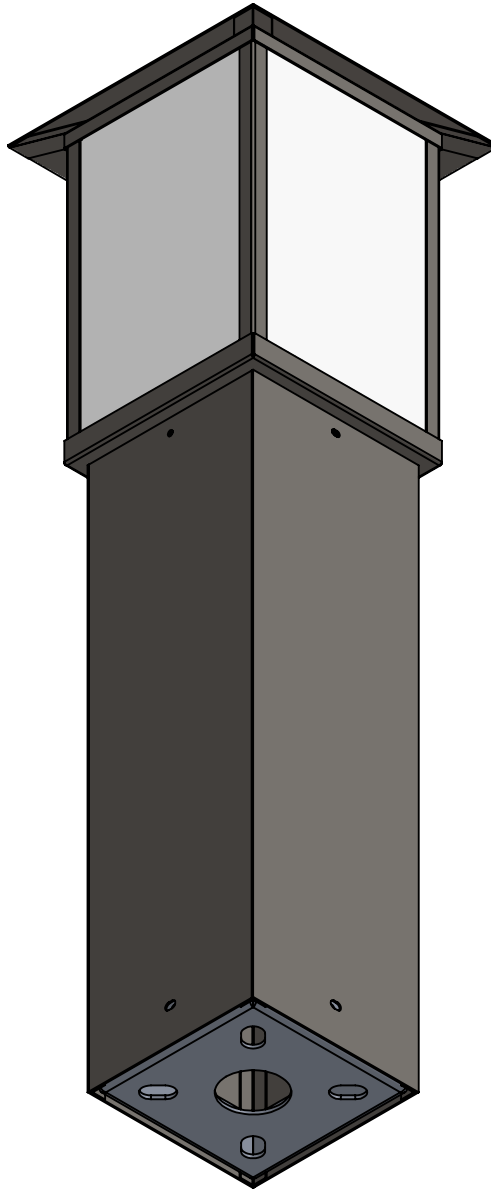
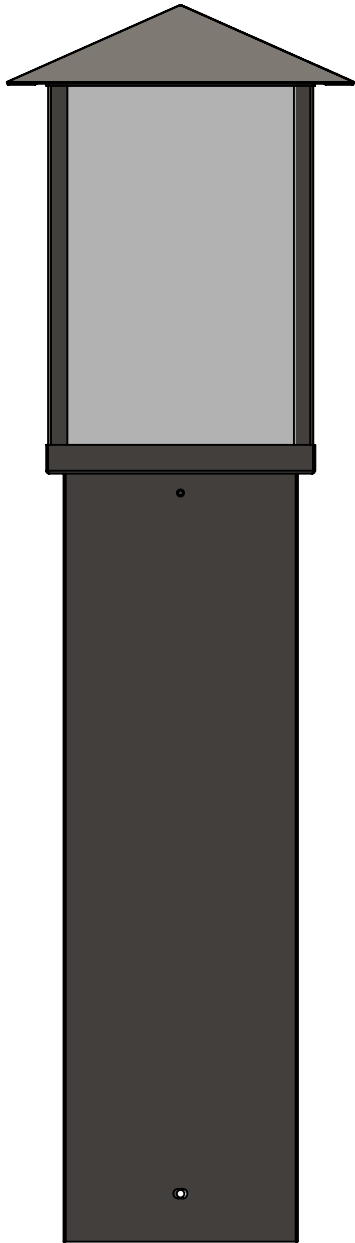

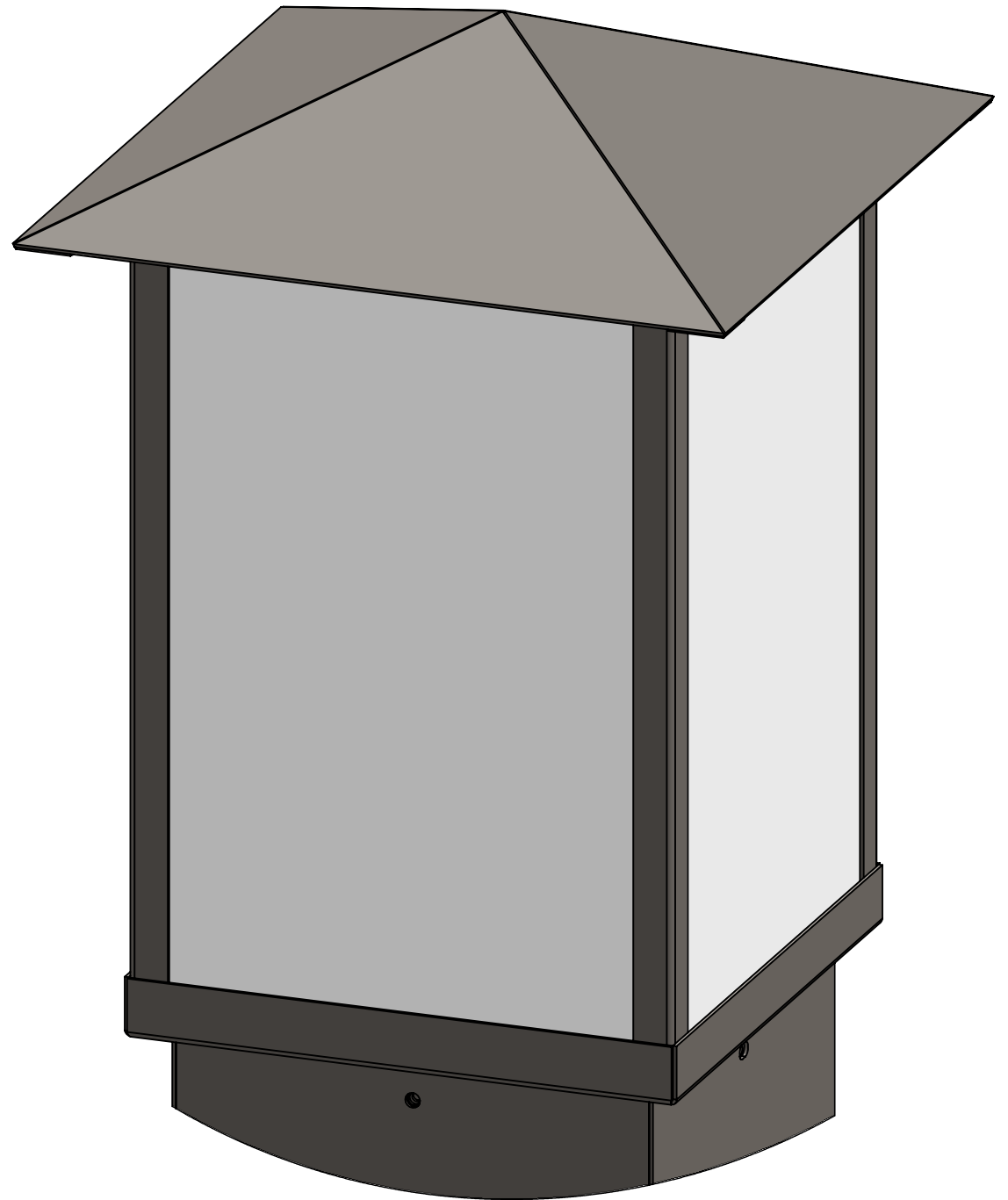
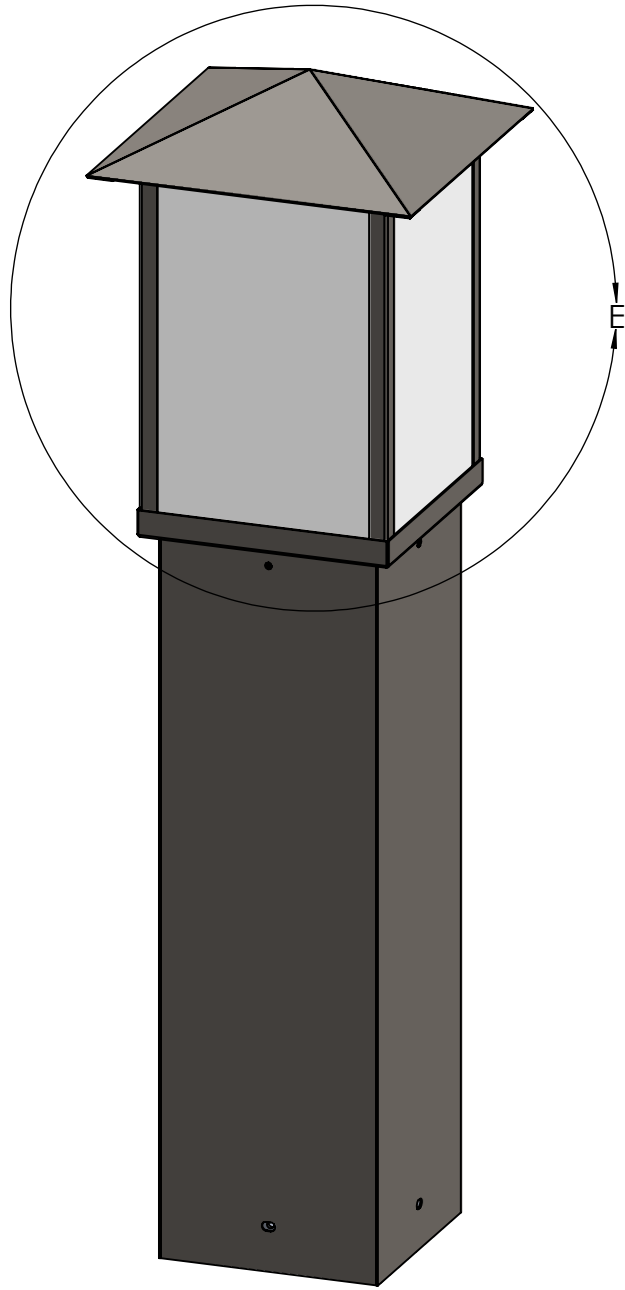

DETAIL E
SCALE 1 : 2

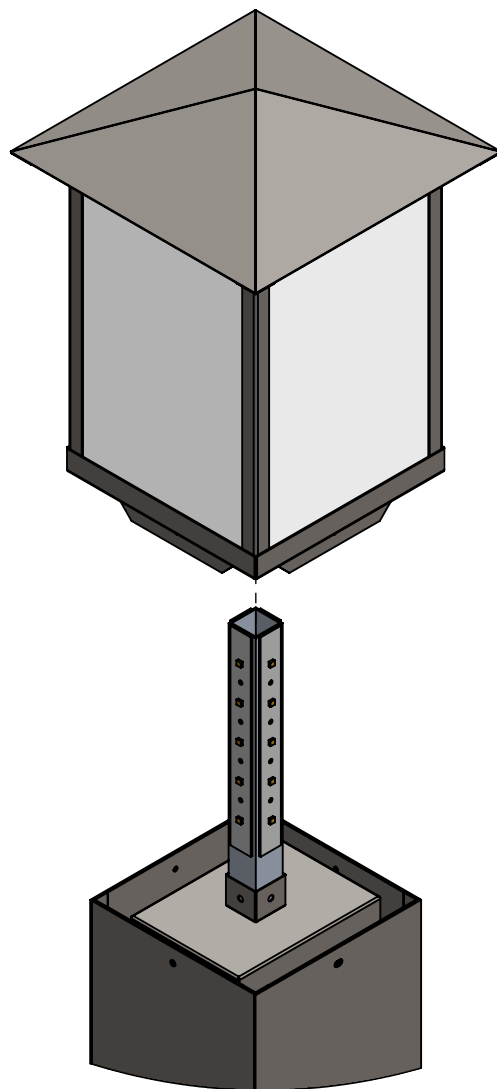
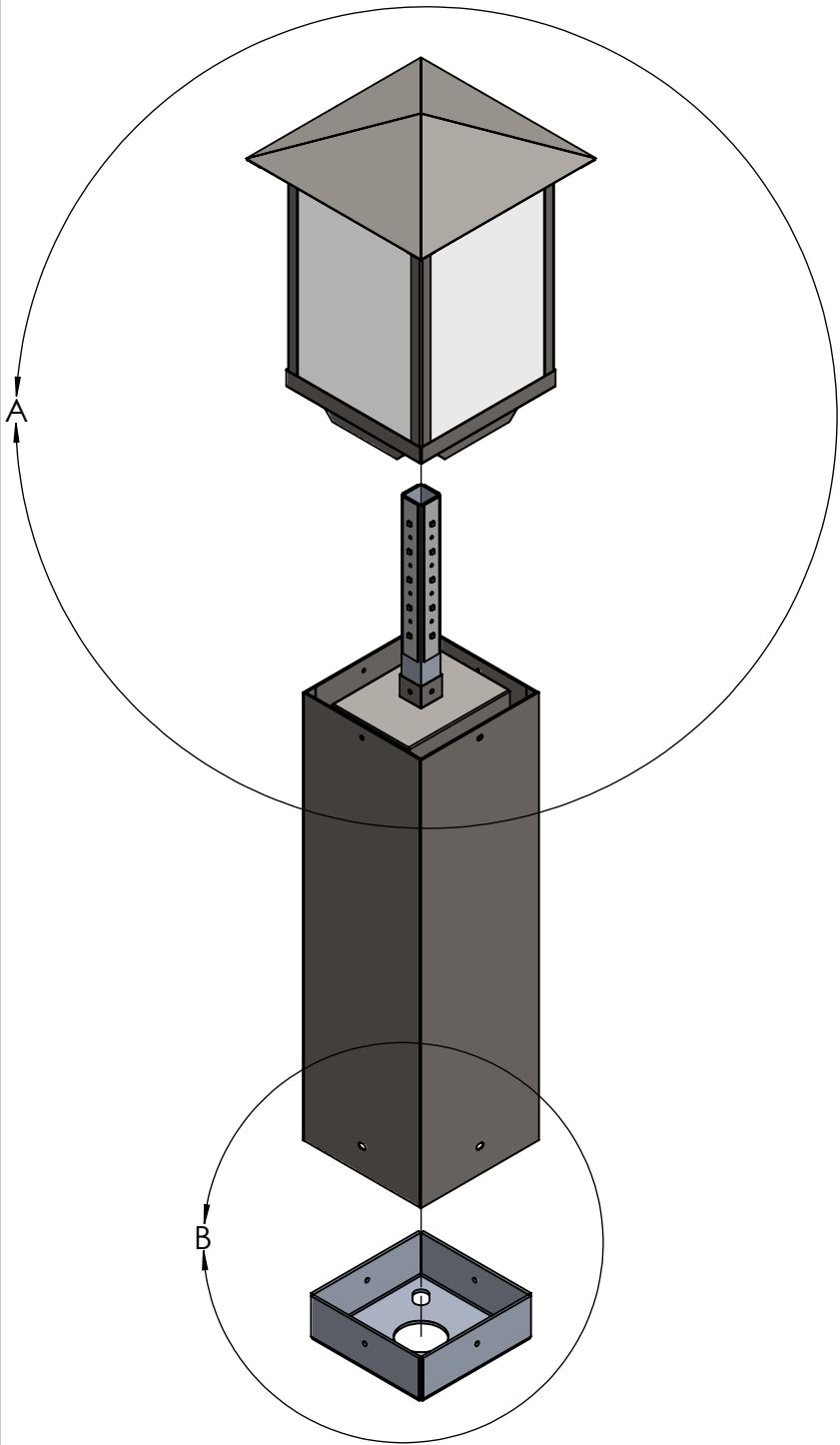

DETAIL A
SCALE 1 : 5

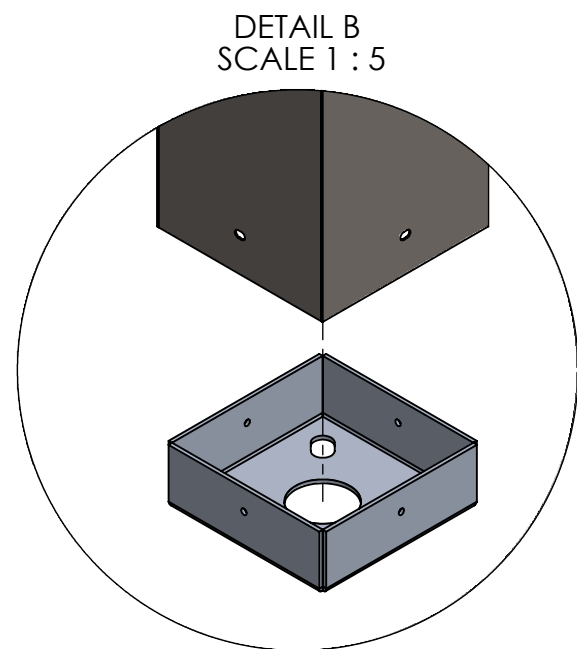

DETAIL B
SCALE 1 : 5

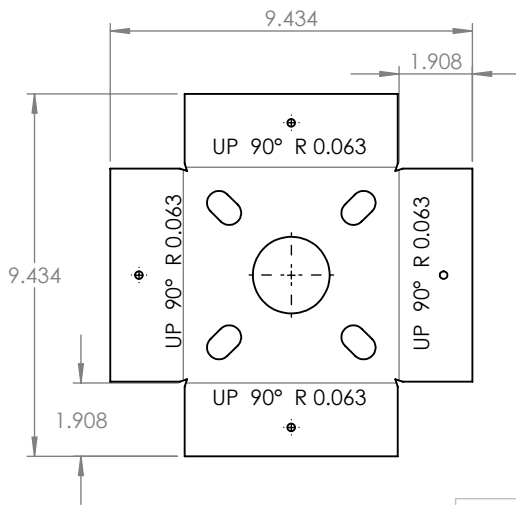

ANCHOR PLATE

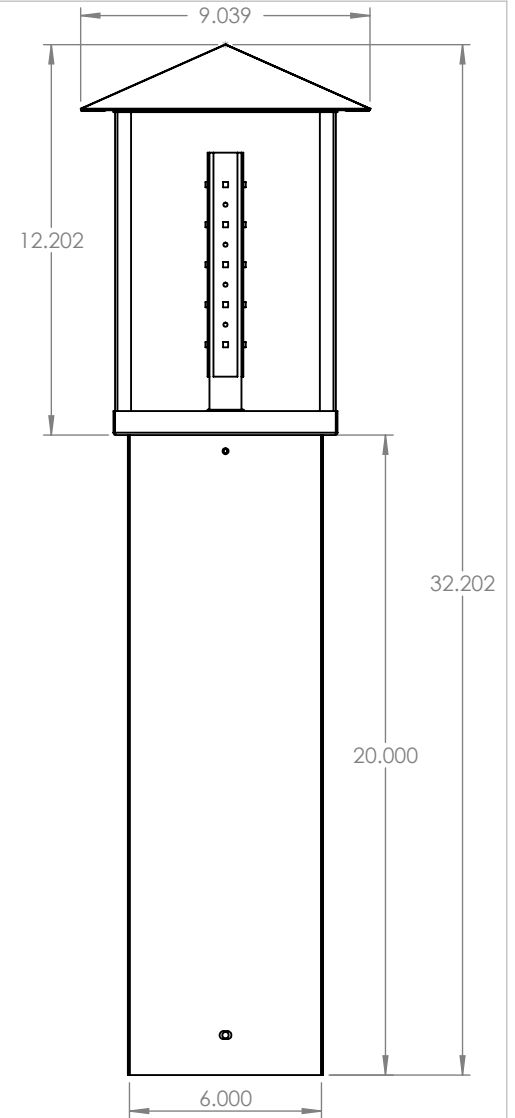
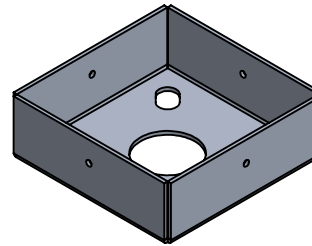

PROPRIETARY AND CONFIDENTIAL
 THE INFORMATION CONTAINED IN THIS DRAWING IS THE SOLE PROPERTY OF <INSERT COMPANY NAME HERE>. ANY REPRODUCTION IN PART OR AS A WHOLE WITHOUT THE WRITTEN PERMISSION OF <INSERT COMPANY NAME HERE> IS PROHIBITED.

		UNLESS OTHERWISE SPECIFIED:		NAME	DATE
		DIMENSIONS ARE IN INCHES	DRAWN	JC	
		TOLERANCES:	CHECKED		
		FRACTIONAL ±	ENG APPR.		
		ANGULAR: MACH ± BEND ±	MFG APPR.		
		TWO PLACE DECIMAL ±	Q.A.		
		THREE PLACE DECIMAL ±	COMMENTS:		
		INTERPRET GEOMETRIC TOLERANCING PER:			
		MATERIAL			
NEXT ASSY	USED ON	FINISH			
APPLICATION		DO NOT SCALE DRAWING			

OVERALL HEIGHT ASSEMBLY		
TITLE: B30618L-AB-A-TPS-30K		
SIZE A	DWG. NO.	REV
SCALE: 1:10	WEIGHT:	SHEET 5 OF 10

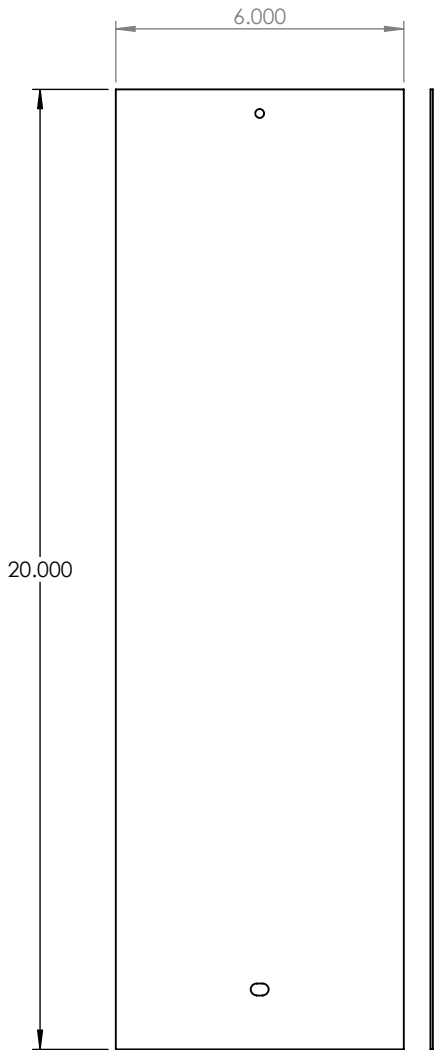

BODY SIDE 1

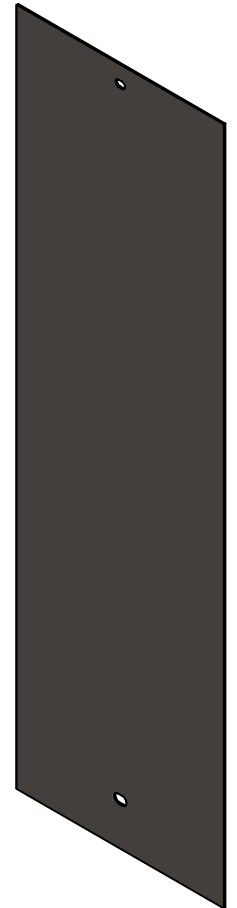
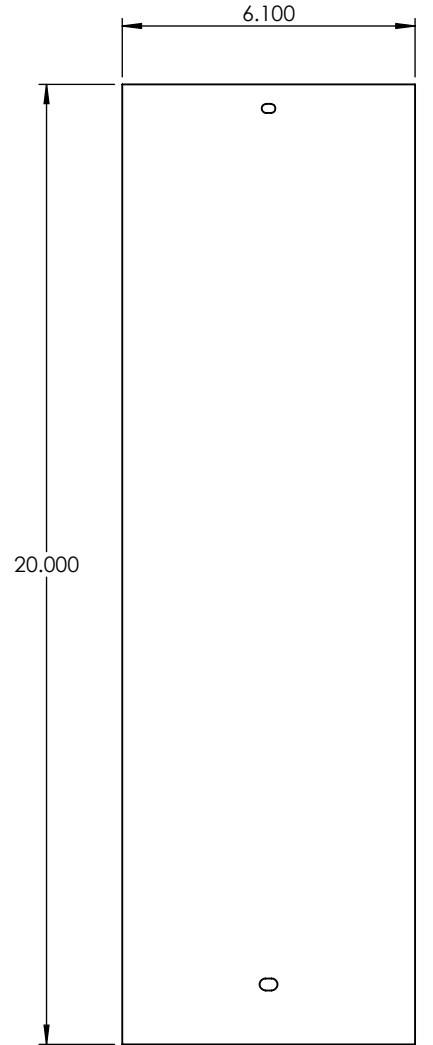

BODY SIDE 2

PROPRIETARY AND CONFIDENTIAL
 THE INFORMATION CONTAINED IN THIS DRAWING IS THE SOLE PROPERTY OF <INSERT COMPANY NAME HERE>. ANY REPRODUCTION IN PART OR AS A WHOLE WITHOUT THE WRITTEN PERMISSION OF <INSERT COMPANY NAME HERE> IS PROHIBITED.

		INTERPRET GEOMETRIC TOLERANCING PER:
		MATERIAL
NEXT ASSY	USED ON	FINISH
APPLICATION		DO NOT SCALE DRAWING

UNLESS OTHERWISE SPECIFIED:	NAME	DATE
DIMENSIONS ARE IN INCHES	DRAWN	JC
TOLERANCES:	CHECKED	
FRACTIONAL ±	ENG APPR.	
ANGULAR: MACH ± BEND ±	MFG APPR.	
TWO PLACE DECIMAL ±	Q.A.	
THREE PLACE DECIMAL ±	COMMENTS:	

18 GAUGE		
TITLE: B30618L-AB-A-TPS-30K		
SIZE A	DWG. NO.	REV
SCALE: 1:4	WEIGHT:	SHEET 6 OF 10

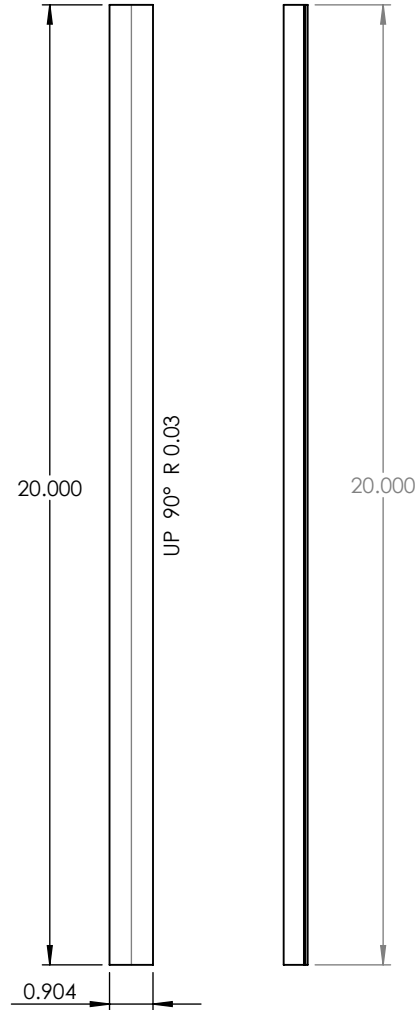
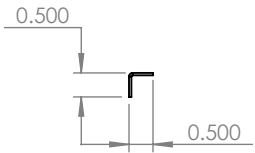

BOTTOM RIB

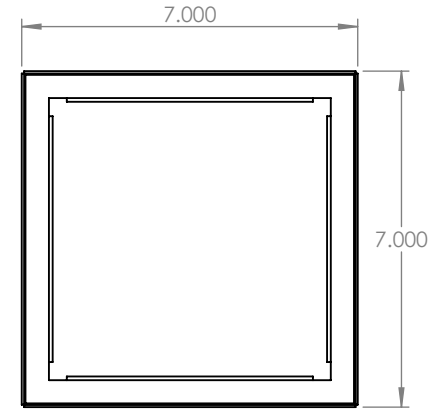
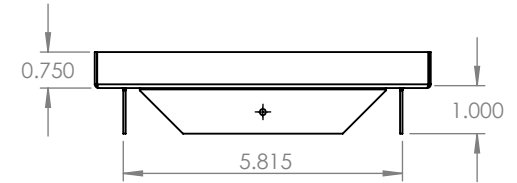
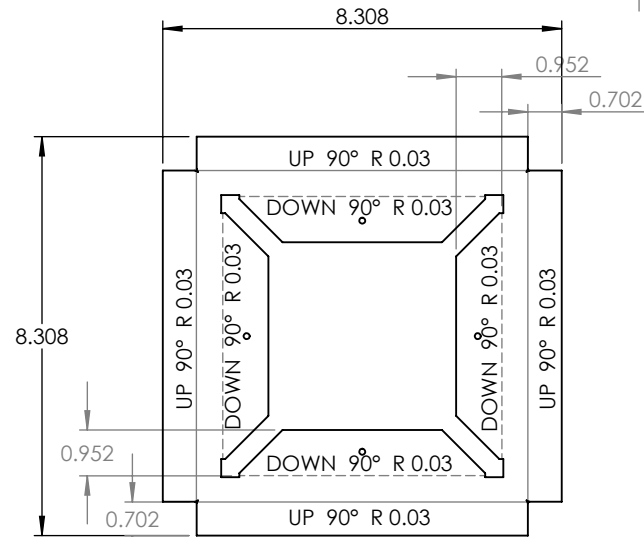

CAGE BASE

PROPRIETARY AND CONFIDENTIAL
 THE INFORMATION CONTAINED IN THIS DRAWING IS THE SOLE PROPERTY OF <INSERT COMPANY NAME HERE>. ANY REPRODUCTION IN PART OR AS A WHOLE WITHOUT THE WRITTEN PERMISSION OF <INSERT COMPANY NAME HERE> IS PROHIBITED.

		UNLESS OTHERWISE SPECIFIED:
		DIMENSIONS ARE IN INCHES
		TOLERANCES:
		FRACTIONAL ±
		ANGULAR: MACH ± BEND ±
		TWO PLACE DECIMAL ±
		THREE PLACE DECIMAL ±
		INTERPRET GEOMETRIC TOLERANCING PER:
		MATERIAL
NEXT ASSY	USED ON	FINISH
APPLICATION		DO NOT SCALE DRAWING

	NAME	DATE
DRAWN		
CHECKED		
ENG APPR.		
MFG APPR.		
Q.A.		
COMMENTS:		

18 GAUGE		
TITLE:		
B30618L-AB-A-TPS-30K		
SIZE	DWG. NO.	REV
A		
SCALE: 1:4	WEIGHT:	SHEET 7 OF 10

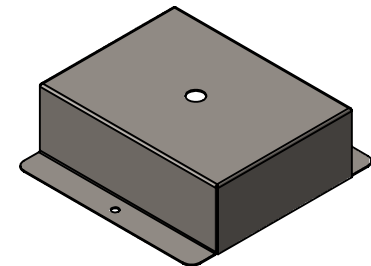
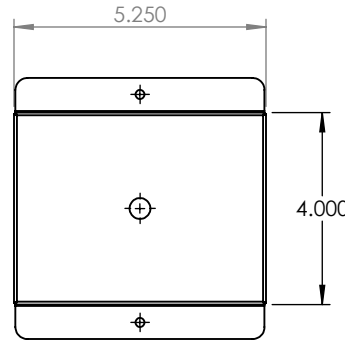
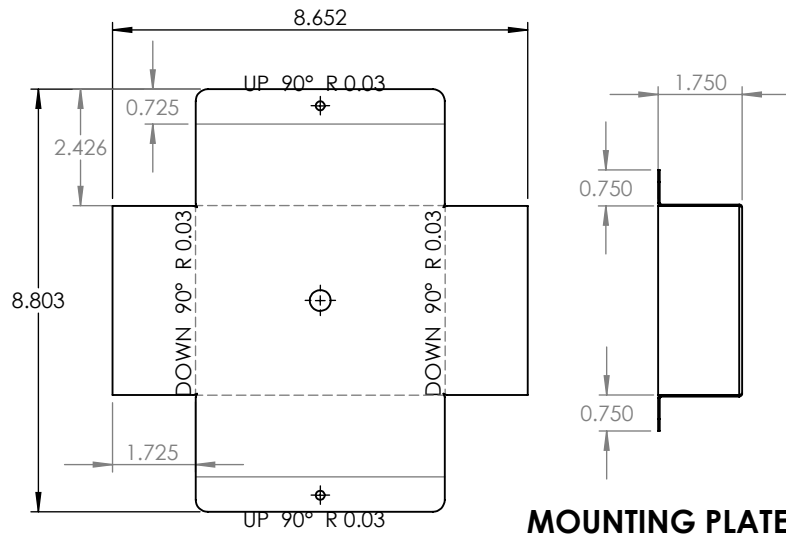
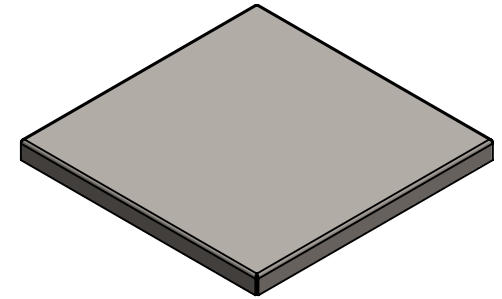
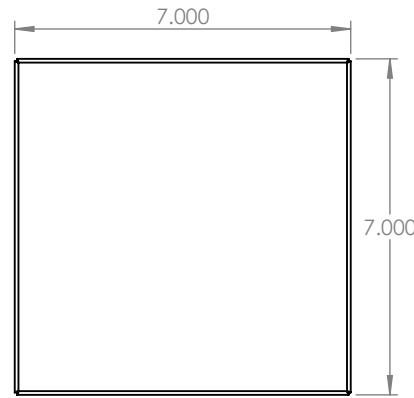
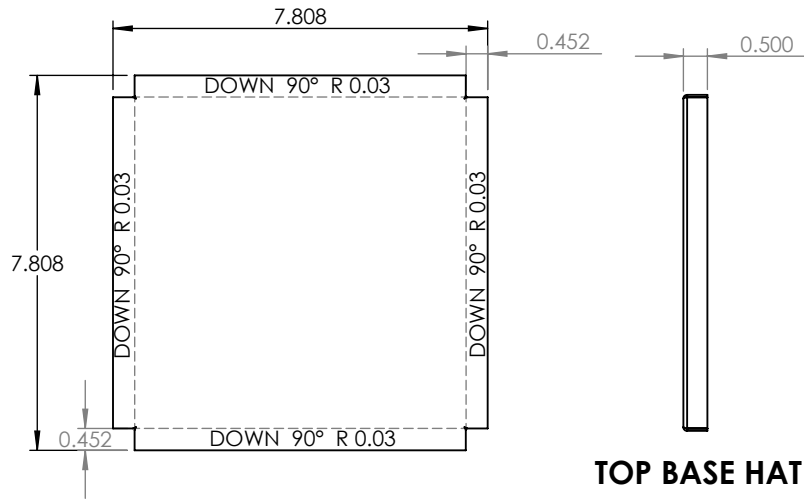

PROPRIETARY AND CONFIDENTIAL
 THE INFORMATION CONTAINED IN THIS DRAWING IS THE SOLE PROPERTY OF <INSERT COMPANY NAME HERE>. ANY REPRODUCTION IN PART OR AS A WHOLE WITHOUT THE WRITTEN PERMISSION OF <INSERT COMPANY NAME HERE> IS PROHIBITED.

		INTERPRET GEOMETRIC TOLERANCING PER:
		MATERIAL
NEXT ASSY	USED ON	FINISH
APPLICATION		DO NOT SCALE DRAWING

UNLESS OTHERWISE SPECIFIED:

DIMENSIONS ARE IN INCHES
 TOLERANCES:
 FRACTIONAL ±
 ANGULAR: MACH ± BEND ±
 TWO PLACE DECIMAL ±
 THREE PLACE DECIMAL ±

	NAME	DATE
DRAWN		
CHECKED		
ENG APPR.		
MFG APPR.		
Q.A.		
COMMENTS:		

18 GAUGE		
TITLE: B30618L-AB-A-TPS-30K		
SIZE A	DWG. NO.	REV
SCALE: 1:4	WEIGHT:	SHEET 8 OF 10

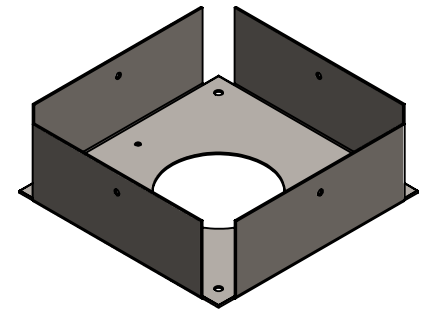
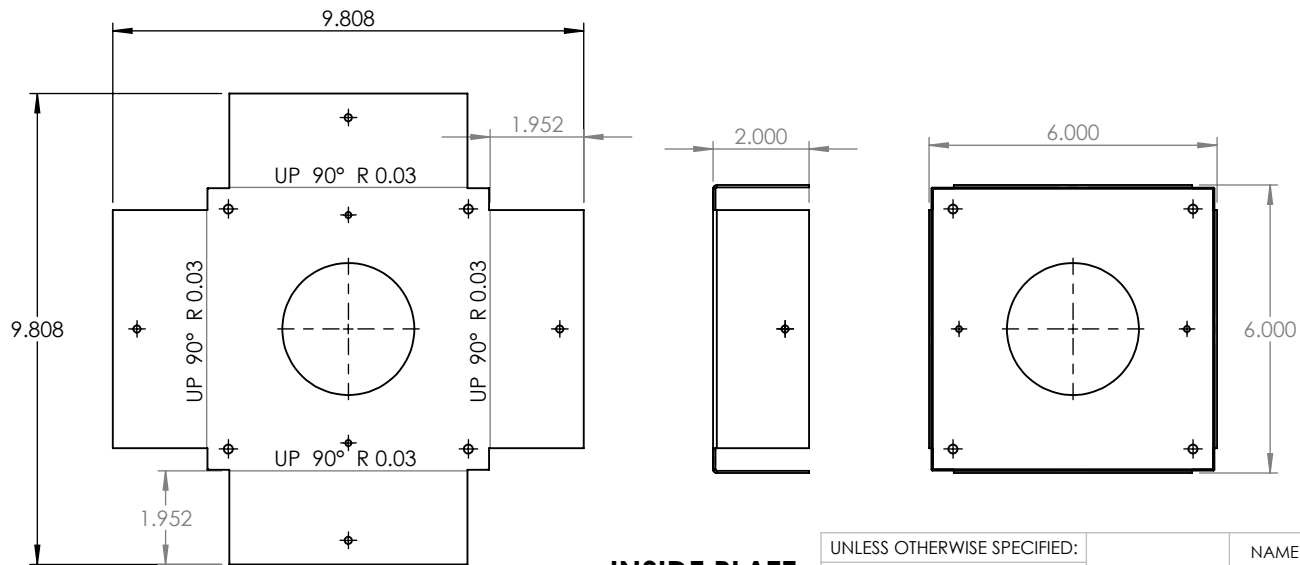
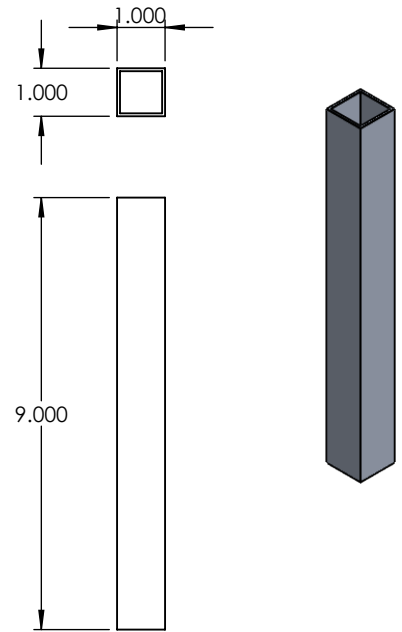
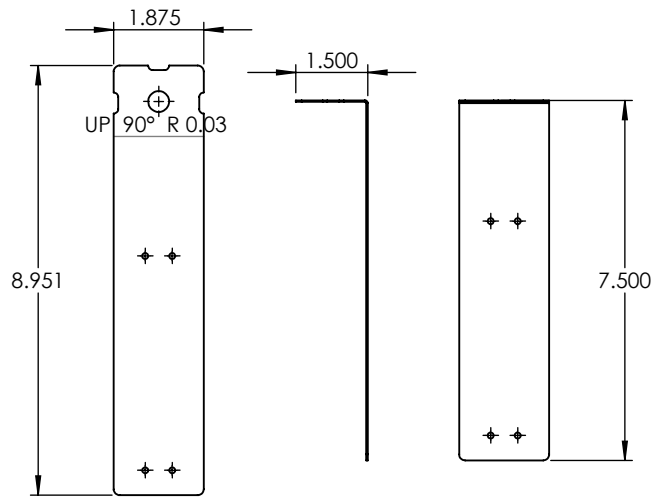

INSIDE PLATE

PROPRIETARY AND CONFIDENTIAL
 THE INFORMATION CONTAINED IN THIS DRAWING IS THE SOLE PROPERTY OF <INSERT COMPANY NAME HERE>. ANY REPRODUCTION IN PART OR AS A WHOLE WITHOUT THE WRITTEN PERMISSION OF <INSERT COMPANY NAME HERE> IS PROHIBITED.

NEXT ASSY	USED ON
APPLICATION	

UNLESS OTHERWISE SPECIFIED:		NAME	DATE
DIMENSIONS ARE IN INCHES		DRAWN	JC
TOLERANCES:		CHECKED	
FRACTIONAL ±		ENG APPR.	
ANGULAR: MACH ± BEND ±		MFG APPR.	
TWO PLACE DECIMAL ±		Q.A.	
THREE PLACE DECIMAL ±		COMMENTS:	
INTERPRET GEOMETRIC TOLERANCING PER:			
MATERIAL			
FINISH			
DO NOT SCALE DRAWING			

18 GAUGE		
TITLE:		
B30618L-AB-A-TPS-30K		
SIZE	DWG. NO.	REV
A		
SCALE: 1:4	WEIGHT:	SHEET 9 OF 10

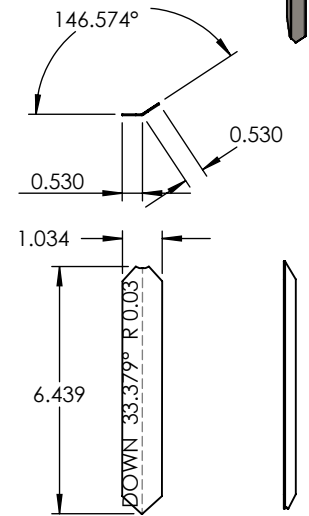
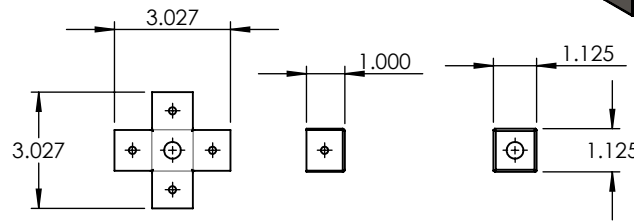
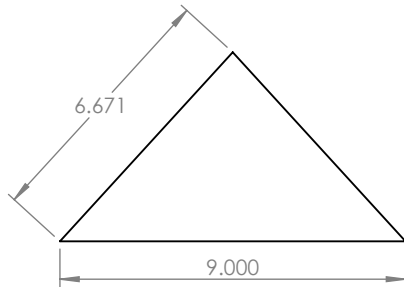
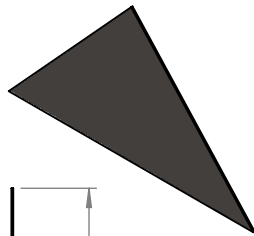
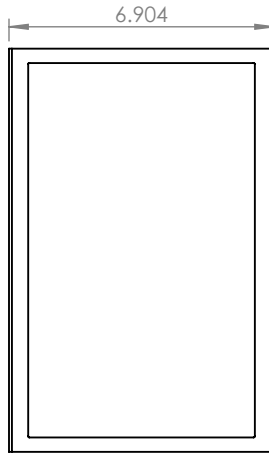
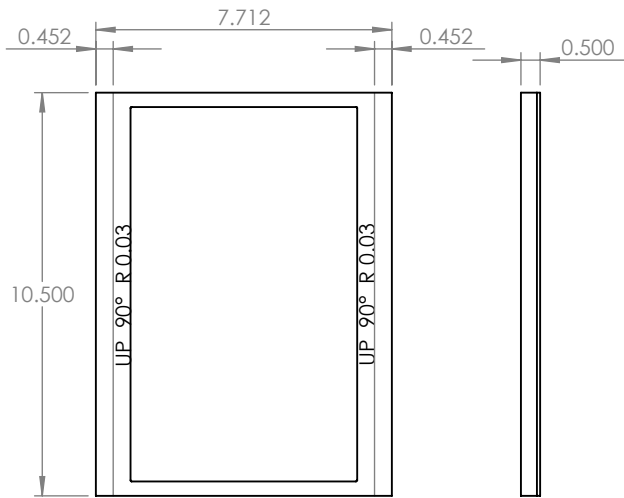

TRIANGLE

TRIANGLE FLANGE

PROPRIETARY AND CONFIDENTIAL
 THE INFORMATION CONTAINED IN THIS DRAWING IS THE SOLE PROPERTY OF <INSERT COMPANY NAME HERE>. ANY REPRODUCTION IN PART OR AS A WHOLE WITHOUT THE WRITTEN PERMISSION OF <INSERT COMPANY NAME HERE> IS PROHIBITED.

		UNLESS OTHERWISE SPECIFIED:	NAME	DATE
		DIMENSIONS ARE IN INCHES	DRAWN	JC
		TOLERANCES:	CHECKED	
		FRACTIONAL ±	ENG APPR.	
		ANGULAR: MACH ± BEND ±	MFG APPR.	
		TWO PLACE DECIMAL ±	Q.A.	
		THREE PLACE DECIMAL ±	COMMENTS:	
		INTERPRET GEOMETRIC TOLERANCING PER:		
		MATERIAL		
NEXT ASSY	USED ON	FINISH		
APPLICATION		DO NOT SCALE DRAWING		

18 GAUGE		
TITLE: B30618L-AB-A-TPS-30K		
SIZE A	DWG. NO.	REV
SCALE: 1:5	WEIGHT:	SHEET 10 OF 10