

ALL BEND RADIUS .030"

APPLICATION

DO NOT SCALE DRAWING

UNLESS OTHERWISE SPECIFIED:

DIMENSIONS ARE IN INCHES
 TOLERANCES:
 FRACTIONAL ± .003
 ANGULAR: MACH ± .01 BEND ±
 TWO PLACE DECIMAL ±
 THREE PLACE DECIMAL ±.001

INTERPRET GEOMETRIC
 TOLERANCING PER:
 MATERIAL

FINISH

NAME

DATE

DRAWN

CHECKED

ENG APPR.

MFG APPR.

Q.A.

COMMENTS:

TITLE:

OR-20-42-18-L36-MV-1-AB-1-CSM-41K

SIZE DWG. NO.

REV

A TICKET 25936

SCALE: 1:12 WEIGHT:

SHEET 1 OF 12

ITEM NO.	PART NUMBER	DESCRIPTION	QTY.	CUT
1	OR-20-42-18-L36-MV-1-AB-1-CSM-41K-CYLINDER CAP	CONCRETE CAP	1	
2	OR-20-42-18-L36-MV-1-AB-1-CSM-41K-CYLINDER BODY	CONCRETE BODY	1	
3	OR-20-42-18-L36-MV-1-AB-1-CSM-41K-ANCHOR PLATE	ALUMINUM 0.500" PLATE	1	
4	OR-20-42-18-L36-MV-1-AB-1-CSM-41K-LOUVER PLATE	ALUMINUM 0.250" PLATE	1	
5	OR-20-42-18-L36-MV-1-AB-1-CSM-41K-LOUVER PLATE	ALUMINUM 0.250" PLATE	1	
6	OR-20-42-18-L36-MV-1-AB-1-CSM-41K-SQUARE TUBE	ALUMINUM 0.125" PLATE	2	
7	OR-10-42-18-L72-MV-L-W2-DB-1-3-NL-TOP LED TUBE CAP	ALUMINUM 0.0635"	1	
8	OR-20-42-18-L36-MV-1-AB-1-CSM-41K-LED TUBE CAP	ALUMINUM 0.0635"	1	
9	OR-20-42-18-L36-MV-1-AB-1-CSM-41K-DRIVER BRACKET	ALUMINUM 0.0635"	1	
10	OR-20-42-18-L36-MV-1-AB-1-CSM-41K-HORIZONTAL LOUVER	SPUN ALUMINUM 0.0635"	5	
11	OR-20-42-18-L36-MV-1-AB-1-CSM-41K-SPUN LENS COVER	SPUN ALUMINUM 0.080"	1	
12	OR-20-42-18-L36-MV-1-AB-1-CSM-41K-SPUN LENS COVER	SPUN ALUMINUM 0.080"	1	
13	OR-20-42-18-L36-MV-1-AB-1-CSM-41K-THREADED ROD	1/4" THREADED ROD	6	
14	OR-20-42-18-L36-MV-1-AB-1-CSM-41K-0.375" REFLECTOR SPACER	3/8" ALUMINUM CYLINDER	18	
15	OR-20-42-18-L36-MV-1-AB-1-CSM-41K-ACRYLIC	ACRYLIC	1	
16	Altal_LED_PN1019_SHIM PLATE	ALUMINUM 0.125" PLATE	4	
17	ESPEN_VEL29070MVH-1	DRIVER	2	
18	Altal_LED_PN1019_RevC	LED	4	

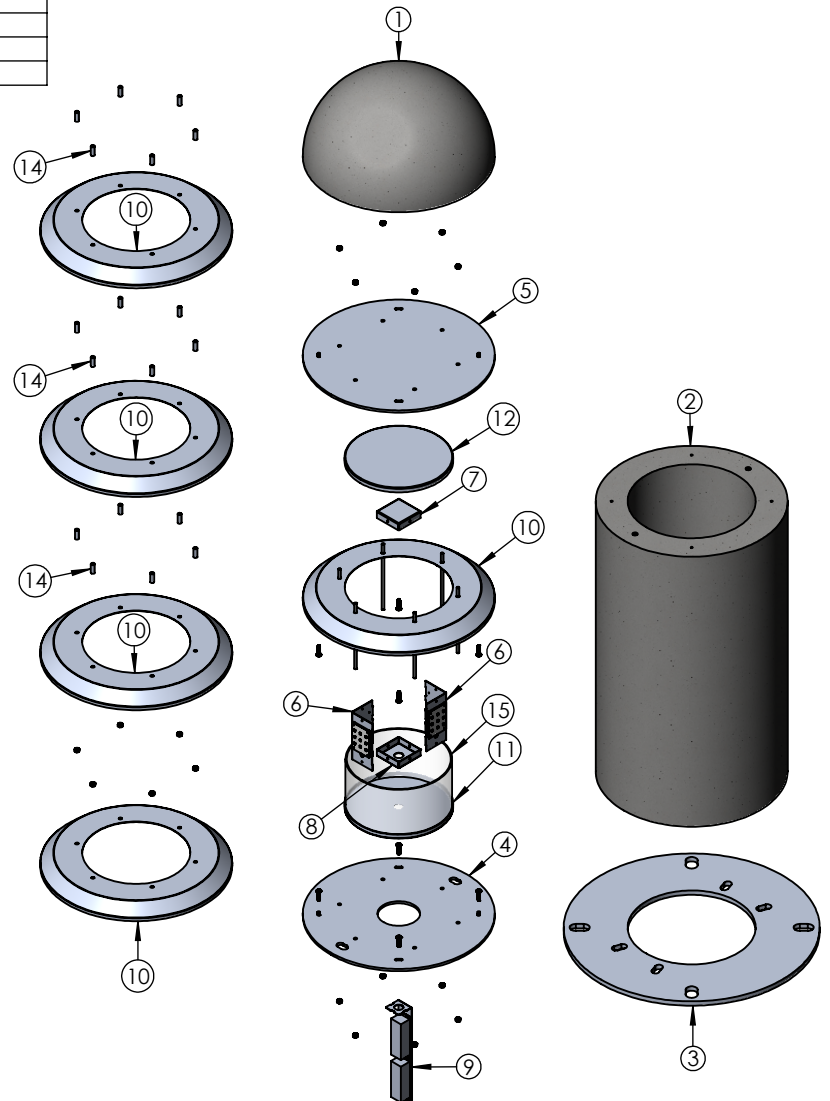

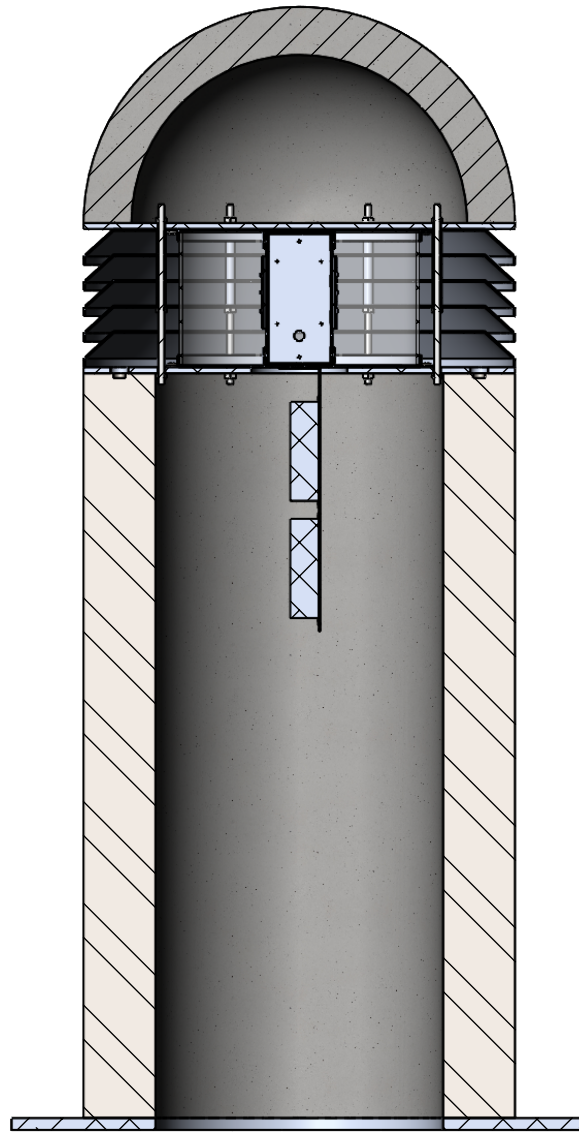
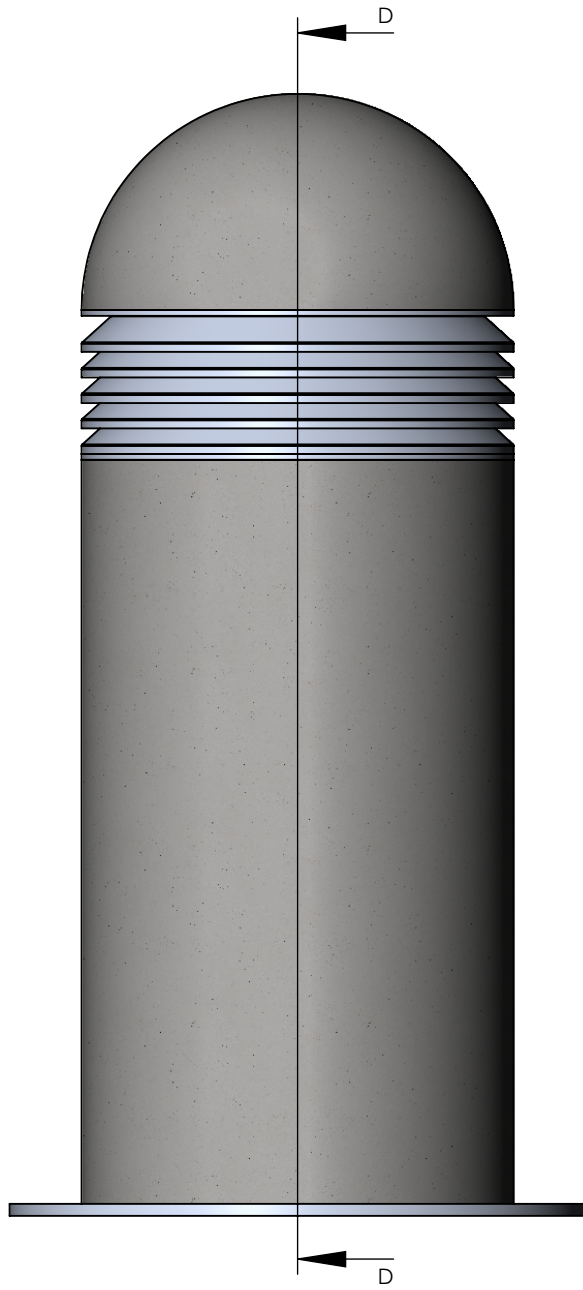

SECTION D-D

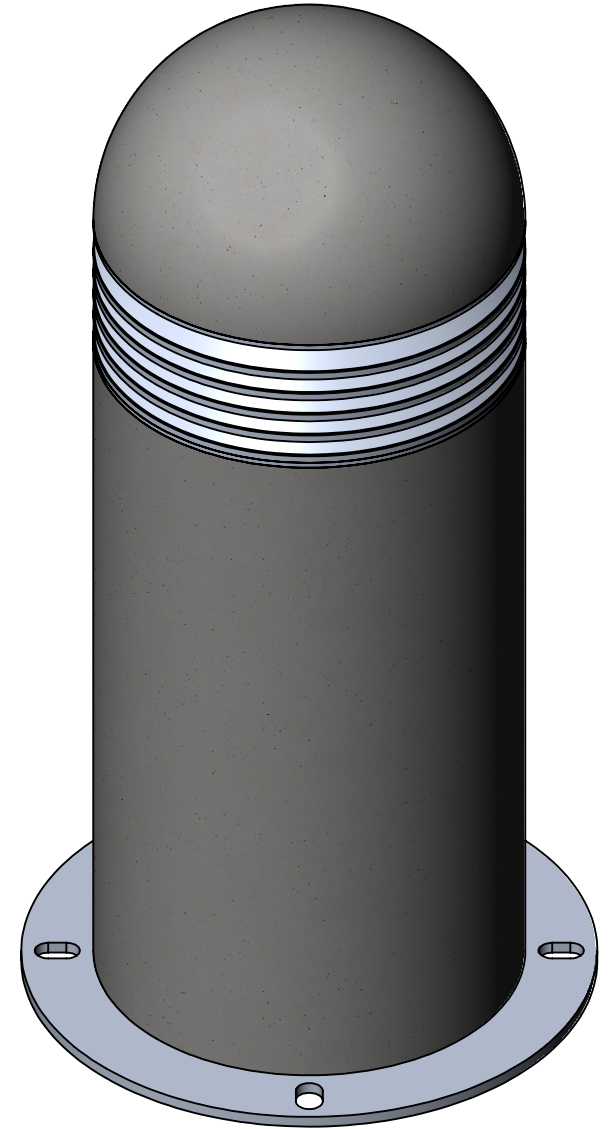

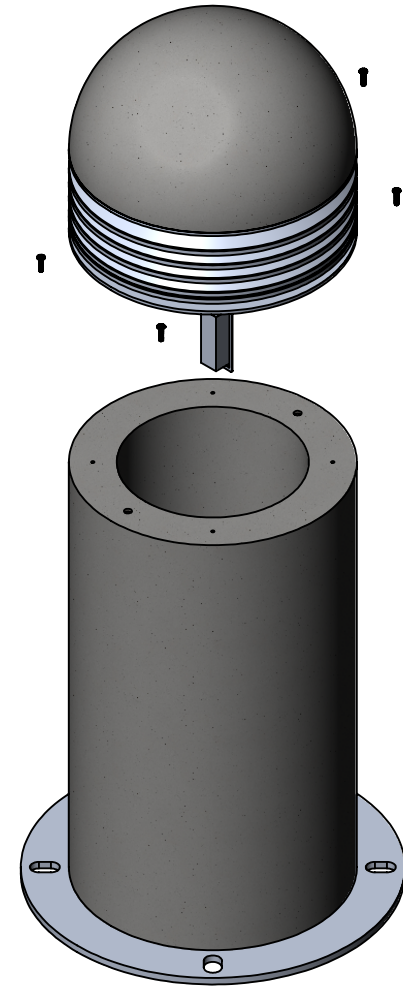
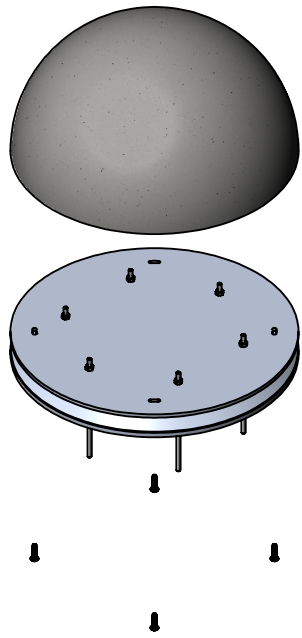
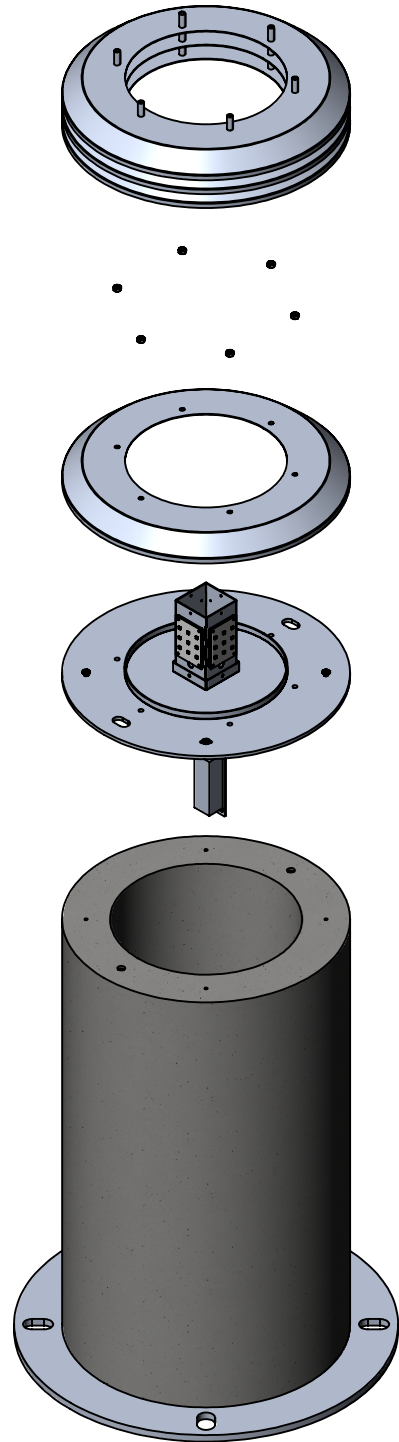

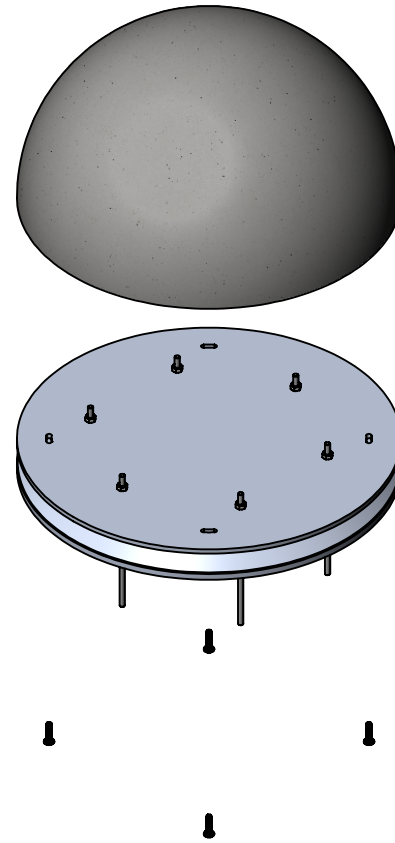
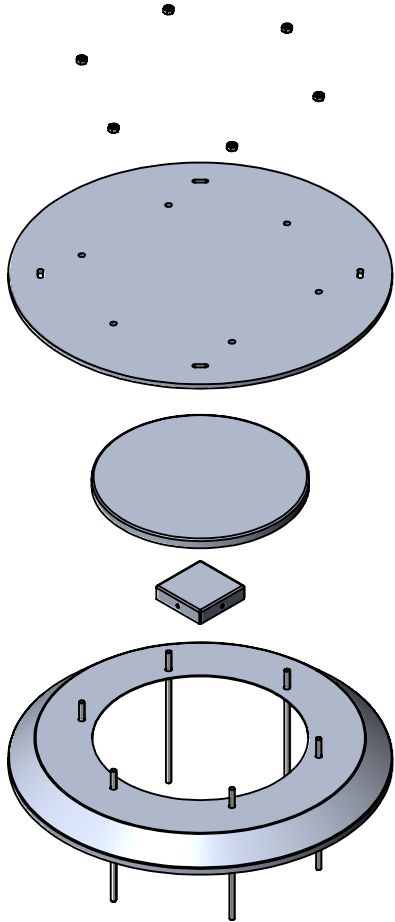
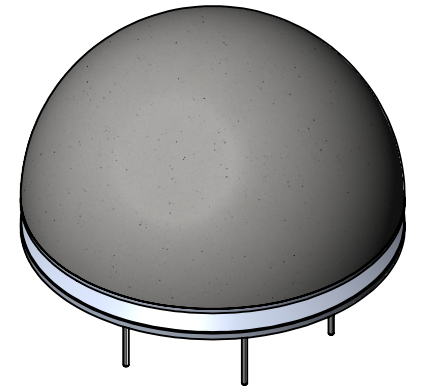
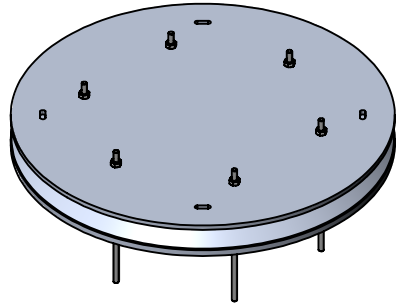

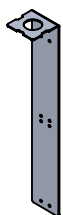
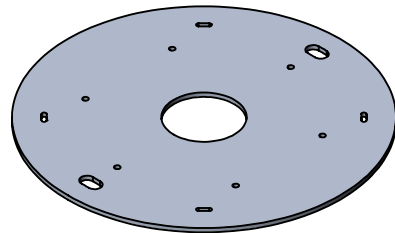
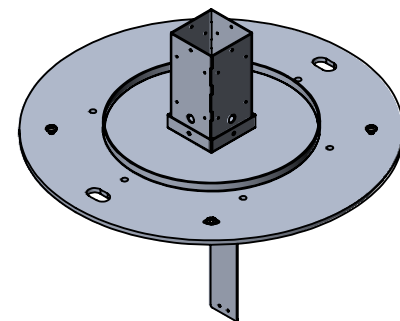
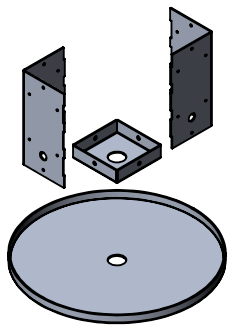
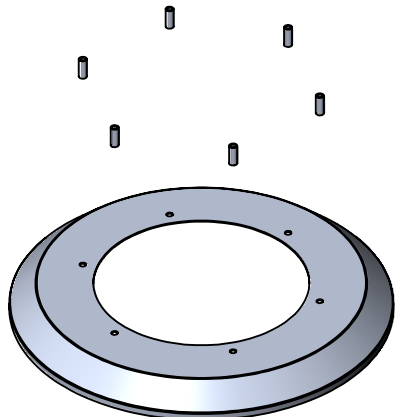
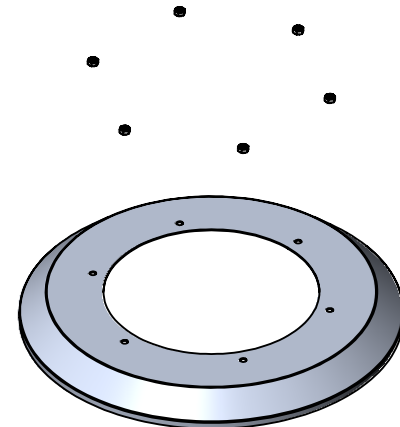
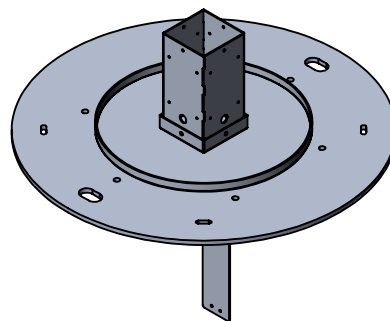
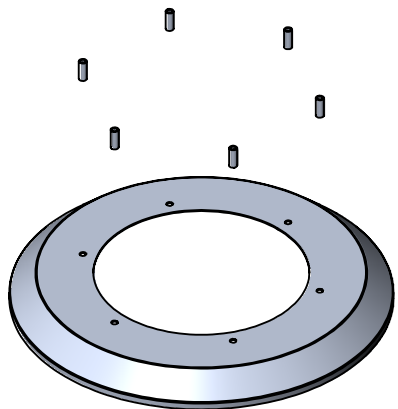
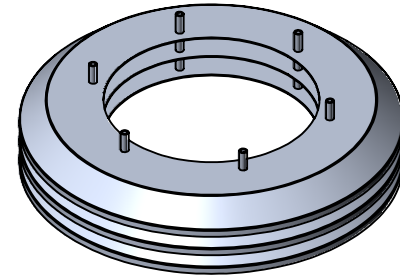
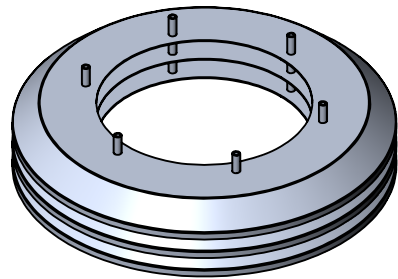
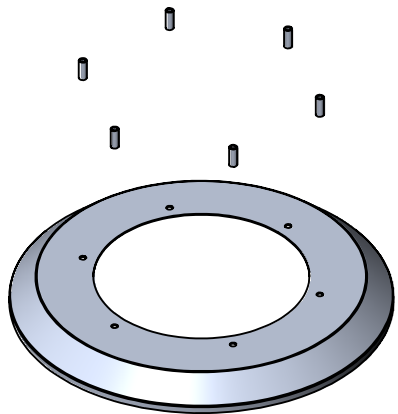

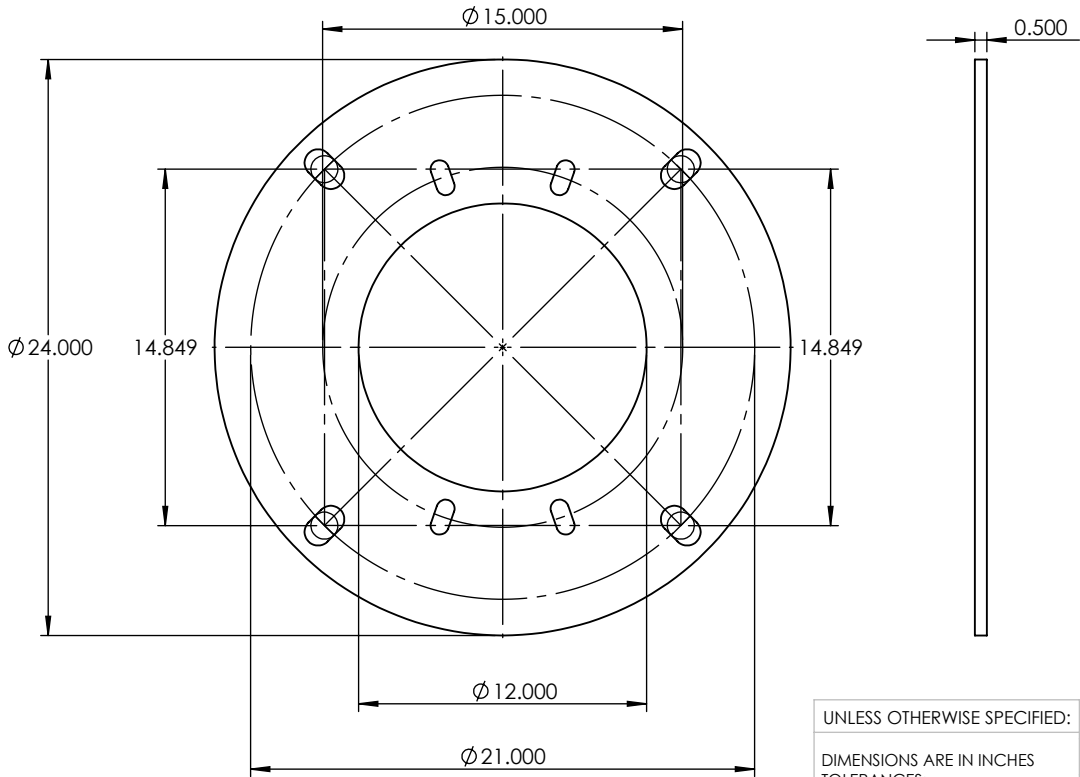
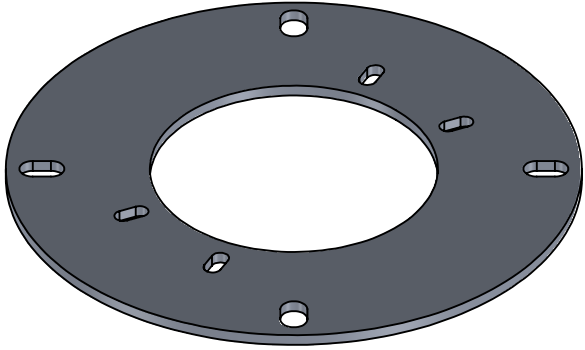

UNLESS OTHERWISE SPECIFIED:		NAME	DATE	ALUMINUM 0.500" PLATE	
DIMENSIONS ARE IN INCHES		DRAWN			
TOLERANCES:		CHECKED		OR-20-42-18-L36-MV-1-AB-1-CSM-41K	
FRACTIONAL \pm		ENG APPR.			
ANGULAR: MACH \pm BEND \pm		MFG APPR.		SCALE: 1:8 WEIGHT: SHEET 7 OF 12	
TWO PLACE DECIMAL \pm		Q.A.			
THREE PLACE DECIMAL \pm		COMMENTS:			
INTERPRET GEOMETRIC TOLERANCING PER:					
MATERIAL					
FINISH					
APPLICATION					
DO NOT SCALE DRAWING					

PROPRIETARY AND CONFIDENTIAL
 THE INFORMATION CONTAINED IN THIS DRAWING IS THE SOLE PROPERTY OF <INSERT COMPANY NAME HERE>. ANY REPRODUCTION IN PART OR AS A WHOLE WITHOUT THE WRITTEN PERMISSION OF <INSERT COMPANY NAME HERE> IS PROHIBITED.

NEXT ASSY	USED ON
APPLICATION	
DO NOT SCALE DRAWING	

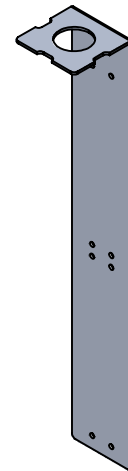
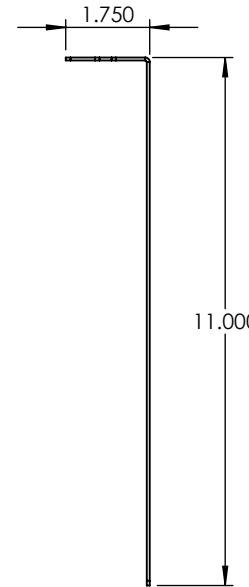
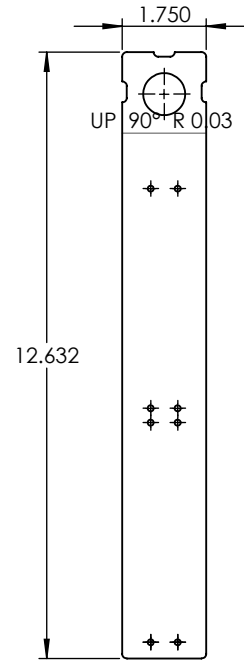
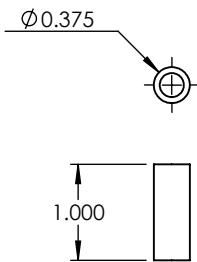
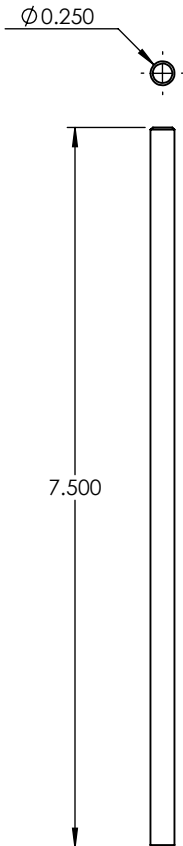
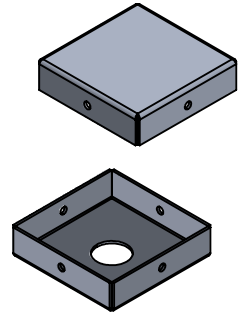
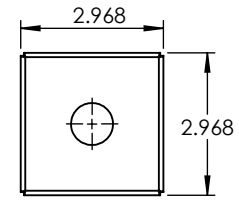
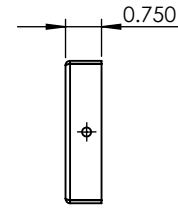
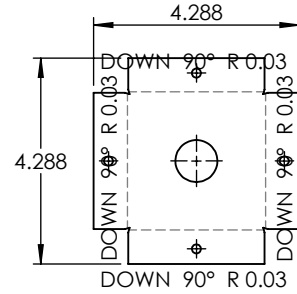
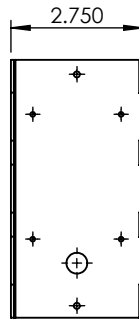
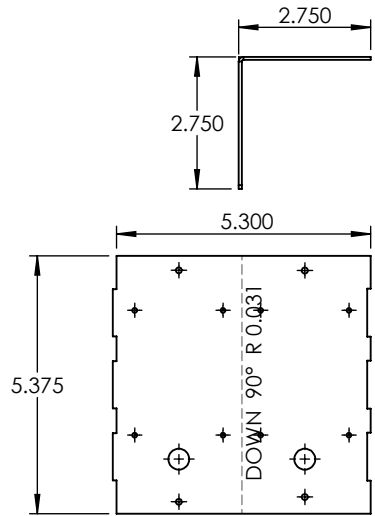

UNLESS OTHERWISE SPECIFIED:

DIMENSIONS ARE IN INCHES
 TOLERANCES:
 FRACTIONAL ±
 ANGULAR: MACH ± BEND ±
 TWO PLACE DECIMAL ±
 THREE PLACE DECIMAL ±

INTERPRET GEOMETRIC
 TOLERANCING PER:

MATERIAL

FINISH

DO NOT SCALE DRAWING

NAME

DATE

DRAWN

CHECKED

ENG APPR.

MFG APPR.

Q.A.

COMMENTS:

ALUMINUM 0.125" PLATE

TITLE:
 OR-20-42-18-L36-MV-1-AB-1-CSM-41K

SIZE DWG. NO.

REV

A

SCALE: 1:4

WEIGHT:

SHEET 8 OF 12

PROPRIETARY AND CONFIDENTIAL
 THE INFORMATION CONTAINED IN THIS
 DRAWING IS THE SOLE PROPERTY OF
 <INSERT COMPANY NAME HERE>. ANY
 REPRODUCTION IN PART OR AS A WHOLE
 WITHOUT THE WRITTEN PERMISSION OF
 <INSERT COMPANY NAME HERE> IS
 PROHIBITED.

NEXT ASSY	USED ON	
APPLICATION		

5

4

3

2

1

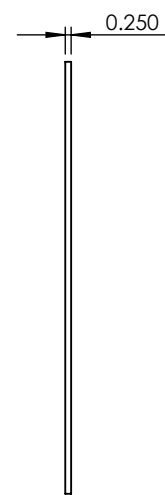
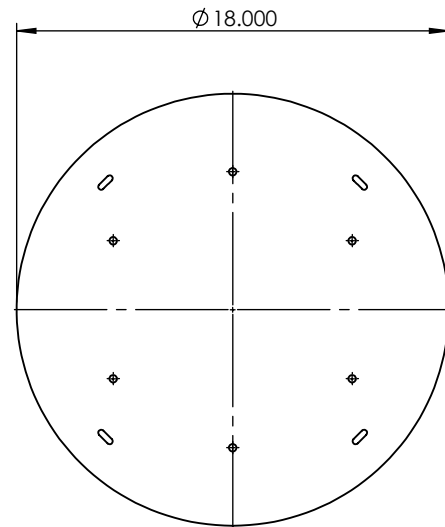
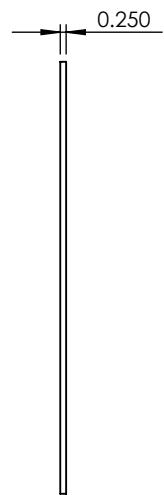
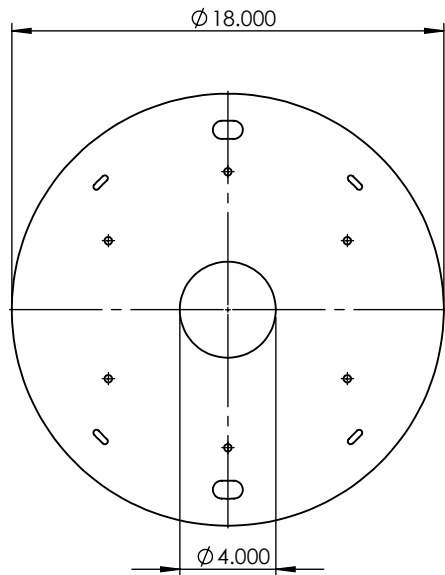
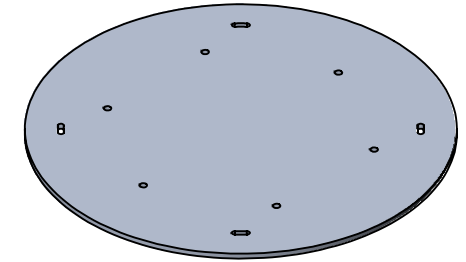
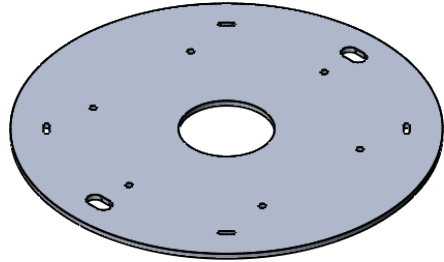

PROPRIETARY AND CONFIDENTIAL
 THE INFORMATION CONTAINED IN THIS DRAWING IS THE SOLE PROPERTY OF <INSERT COMPANY NAME HERE>. ANY REPRODUCTION IN PART OR AS A WHOLE WITHOUT THE WRITTEN PERMISSION OF <INSERT COMPANY NAME HERE> IS PROHIBITED.

NEXT ASSY	USED ON
APPLICATION	

UNLESS OTHERWISE SPECIFIED:
DIMENSIONS ARE IN INCHES
TOLERANCES:
FRACTIONAL ±
ANGULAR: MACH ± BEND ±
TWO PLACE DECIMAL ±
THREE PLACE DECIMAL ±
INTERPRET GEOMETRIC TOLERANCING PER:
MATERIAL
FINISH
DO NOT SCALE DRAWING

	NAME	DATE
DRAWN		
CHECKED		
ENG APPR.		
MFG APPR.		
Q.A.		
COMMENTS:		

ALUMINUM 0.250" PLATE		
TITLE:		
OR-20-42-18-L36-MV-1-AB-1-CSM-41K		
SIZE	DWG. NO.	REV
A		
SCALE: 1:8	WEIGHT:	SHEET 9 OF 12

5

4

3

2

1

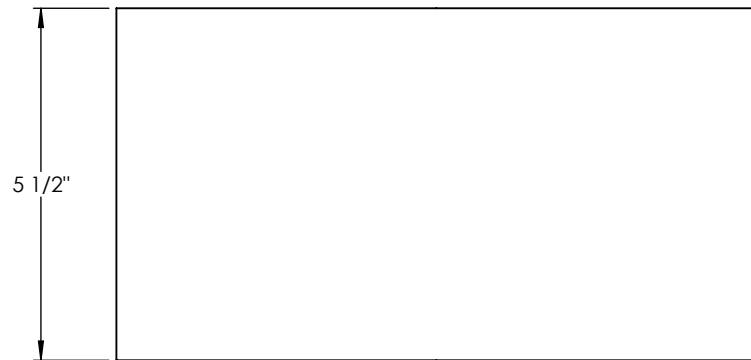
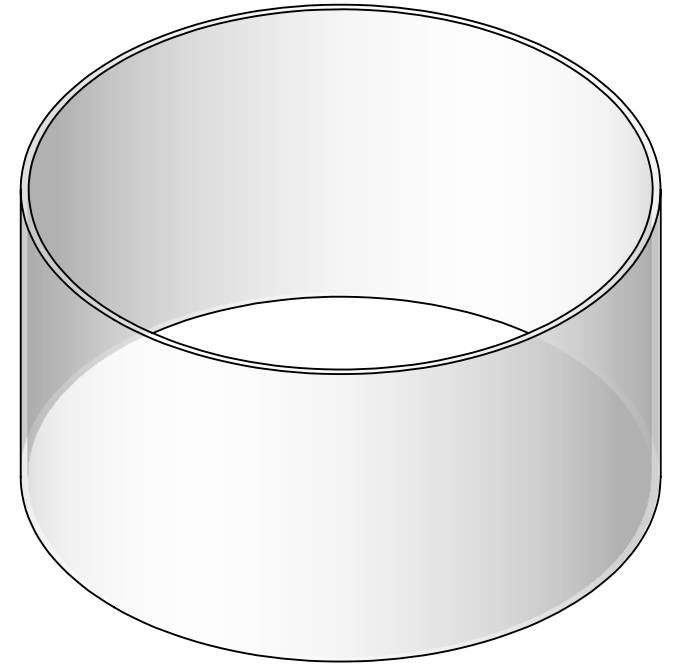
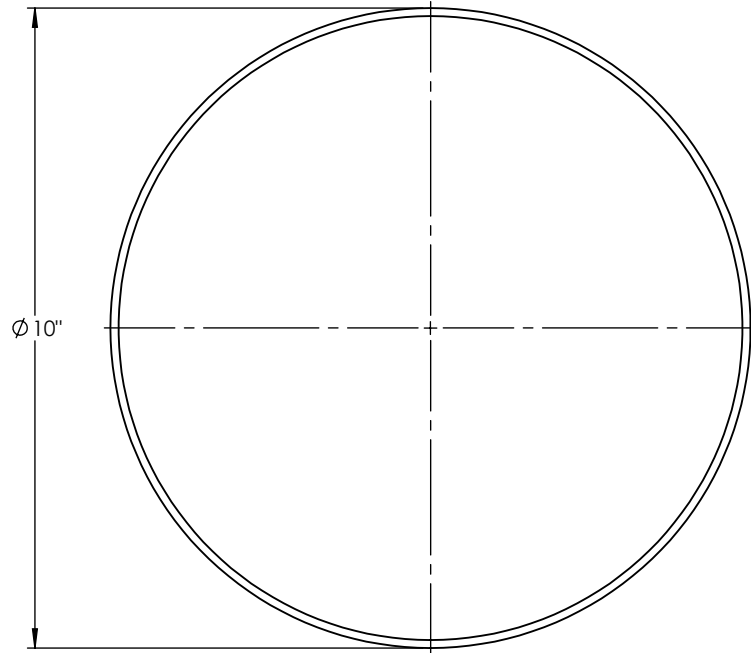

PROPRIETARY AND CONFIDENTIAL
 THE INFORMATION CONTAINED IN THIS DRAWING IS THE SOLE PROPERTY OF <INSERT COMPANY NAME HERE>. ANY REPRODUCTION IN PART OR AS A WHOLE WITHOUT THE WRITTEN PERMISSION OF <INSERT COMPANY NAME HERE> IS PROHIBITED.

		UNLESS OTHERWISE SPECIFIED:	NAME	DATE	ACRYLIC		
		DIMENSIONS ARE IN INCHES TOLERANCES: FRACTIONAL ± ANGULAR: MACH ± BEND ± TWO PLACE DECIMAL ± THREE PLACE DECIMAL ±	DRAWN				TITLE:
		INTERPRET GEOMETRIC TOLERANCING PER:	CHECKED		OR-20-42-18-L36-MV-1-AB-1-CSM-41K		
		MATERIAL	ENG APPR.				
		FINISH	MFG APPR.		SIZE	DWG. NO.	REV
NEXT ASSY	USED ON		Q.A.		A		
APPLICATION		DO NOT SCALE DRAWING	COMMENTS:			SCALE: 1:3	WEIGHT:

ITEM NO.	PART NUMBER	DESCRIPTION	QTY.
1	OR-20-42-18-L36-MV-1-AB-1-CSM-41K-SPUN CONCRETE CAPS	SPUN ALUMINUM 0.080"	1

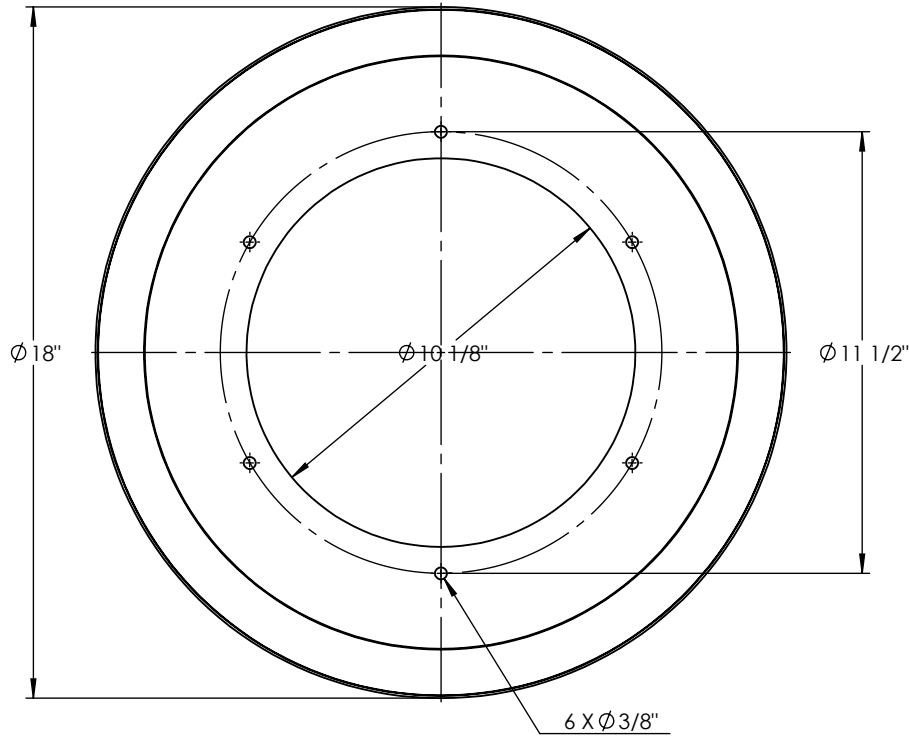
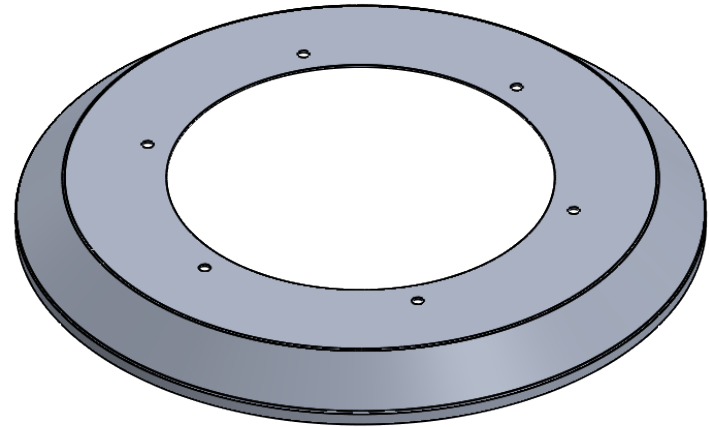
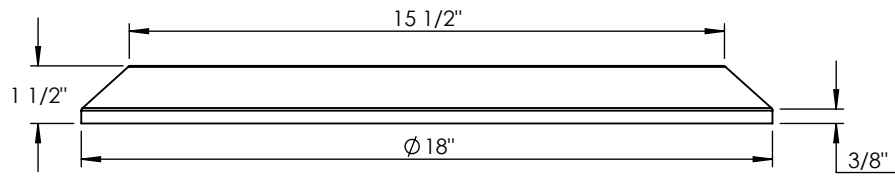

UNLESS OTHERWISE SPECIFIED: DIMENSIONS ARE IN INCHES TOLERANCES: FRACTIONAL ± ANGULAR: MACH ± BEND ± TWO PLACE DECIMAL ± THREE PLACE DECIMAL ±		NAME	DATE	SPUN ALUMINUM 0.0635"		
	DRAWN			TITLE:		
	CHECKED			OR-20-42-18-L36-MV-1-AB-1-CSM-41K		
	ENG APPR.					
INTERPRET GEOMETRIC TOLERANCING PER:				Q.A.		
MATERIAL				COMMENTS:		
FINISH				SIZE	DWG. NO.	REV
				A		
				SCALE: 1:5	WEIGHT:	SHEET 11 OF 12

PROPRIETARY AND CONFIDENTIAL
THE INFORMATION CONTAINED IN THIS DRAWING IS THE SOLE PROPERTY OF <INSERT COMPANY NAME HERE>. ANY REPRODUCTION IN PART OR AS A WHOLE WITHOUT THE WRITTEN PERMISSION OF <INSERT COMPANY NAME HERE> IS PROHIBITED.

NEXT ASSY	USED ON
APPLICATION	

DO NOT SCALE DRAWING

ITEM NO.	PART NUMBER	DESCRIPTION	QTY.
1	OR-20-42-18-L36-MV-1-AB-1-CSM-41K-SPUN LENS COVER	SPUN ALUMINUM 0.080"	1

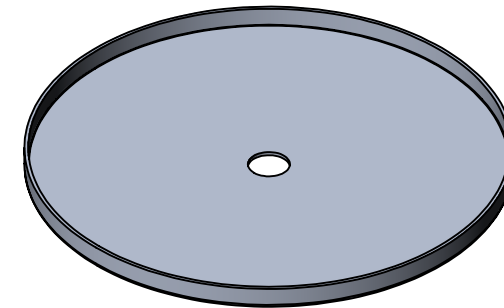
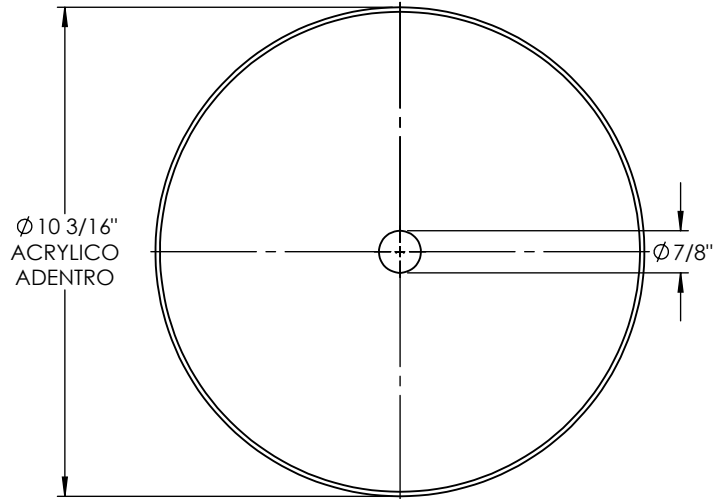
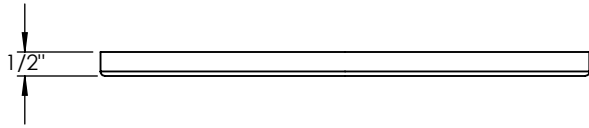
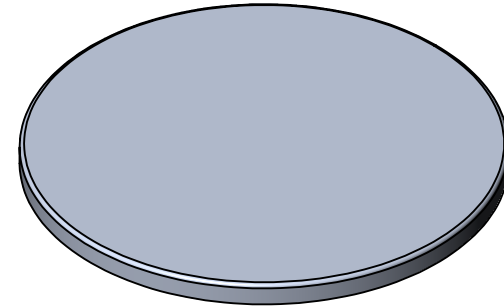

UNLESS OTHERWISE SPECIFIED:		NAME	DATE	SPUN ALUMINUM 0.080"	
DIMENSIONS ARE IN INCHES TOLERANCES: FRACTIONAL \pm ANGULAR: MACH \pm BEND \pm TWO PLACE DECIMAL \pm THREE PLACE DECIMAL \pm		DRAWN			
INTERPRET GEOMETRIC TOLERANCING PER:		CHECKED		OR-20-42-18-L36-MV-1-AB-1-CSM-41K	
		ENG APPR.			
MATERIAL		MFG APPR.		SIZE DWG. NO. REV	
		Q.A.			
FINISH		COMMENTS:		SCALE: 1:4 WEIGHT: SHEET 12 OF 12	
DO NOT SCALE DRAWING					

PROPRIETARY AND CONFIDENTIAL
 THE INFORMATION CONTAINED IN THIS DRAWING IS THE SOLE PROPERTY OF <INSERT COMPANY NAME HERE>. ANY REPRODUCTION IN PART OR AS A WHOLE WITHOUT THE WRITTEN PERMISSION OF <INSERT COMPANY NAME HERE> IS PROHIBITED.

NEXT ASSY	USED ON
APPLICATION	