

ITEM NO.	PART NUMBER	DESCRIPTION	QTY.	CUT
1	GEO-W-24-20W-AB-WF-STB-WET-CSM-41K-BACKPLATE	22 GAUGE	1	
2	GEO-W-24-20W-AB-WF-STB-WET-CSM-41K-LED SPACER	22 GAUGE	1	
3	GEO-W-24-20W-AB-WF-STB-WET-CSM-41K-FIREPLATE	22 GAUGE	1	
4	GEO-W-24-20W-AB-WF-STB-WET-CSM-41K-LENS RAIL	22 GAUGE	2	
5	GEO-W-24-20W-AB-WF-STB-WET-CSM-41K-END CAP	22 GAUGE	2	
6	GEO-W-24-20W-AB-WF-STB-WET-CSM-41K-ALUMINUM BAR	1/2"x1/4" ALUMINUM BAR	1	
7	GEO-W-24-20W-AB-WF-STB-WET-CSM-41K-ACRYLIC	ACRYLIC	1	
8	ESPEN VEL29070MVH-1	DRIVER	1	
9	Alttailed_PN1010_RevD	LED	4	

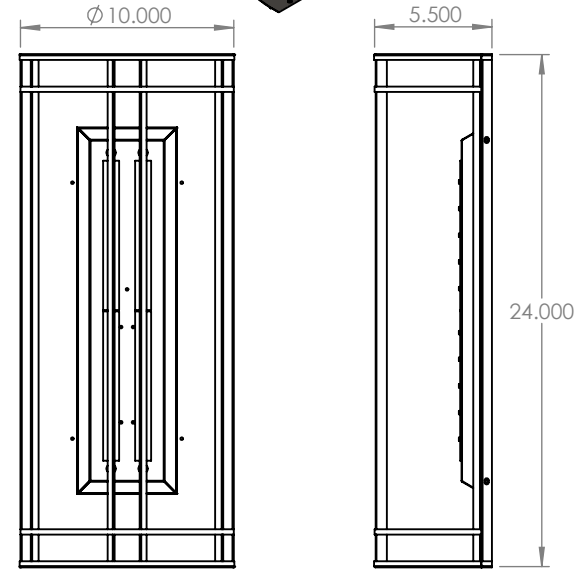
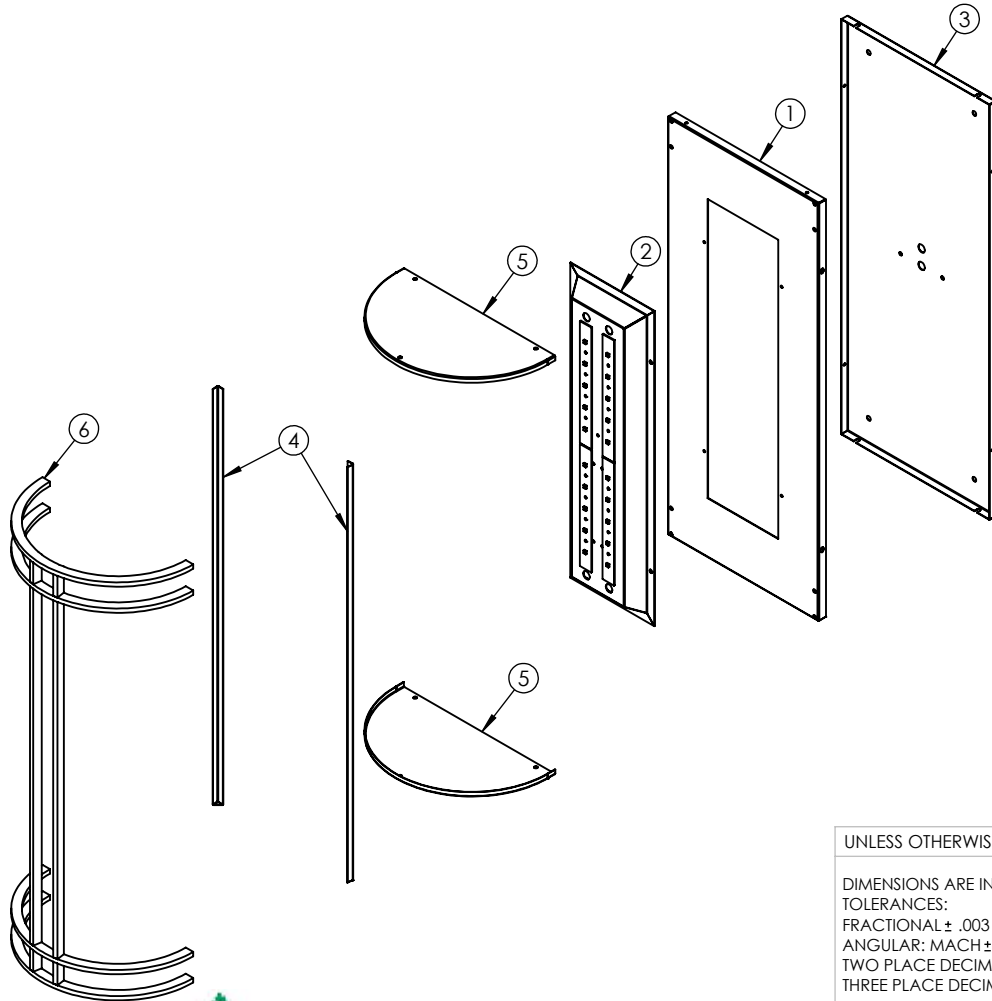
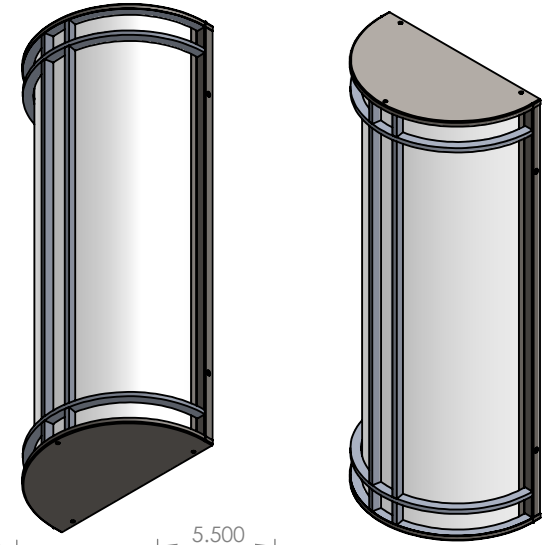

ALL BEND RADIUS 0.030"

APPLICATION

DO NOT SCALE DRAWING

UNLESS OTHERWISE SPECIFIED:

DIMENSIONS ARE IN INCHES
 TOLERANCES:
 FRACTIONAL ± .003
 ANGULAR: MACH ± .01 BEND ±
 TWO PLACE DECIMAL ±
 THREE PLACE DECIMAL ±.001

INTERPRET GEOMETRIC
 TOLERANCING PER:

MATERIAL

FINISH

NAME

DATE

DRAWN

CHECKED

ENG APPR.

MFG APPR.

Q.A.

COMMENTS:

TITLE:

GEO-W-24-20W-AB-WF-STB-WET-CSM-41

SIZE DWG. NO.

REV

A TICKET 25994

SCALE: 1:9 WEIGHT:

SHEET 1 OF 6

5

4

3

2

1

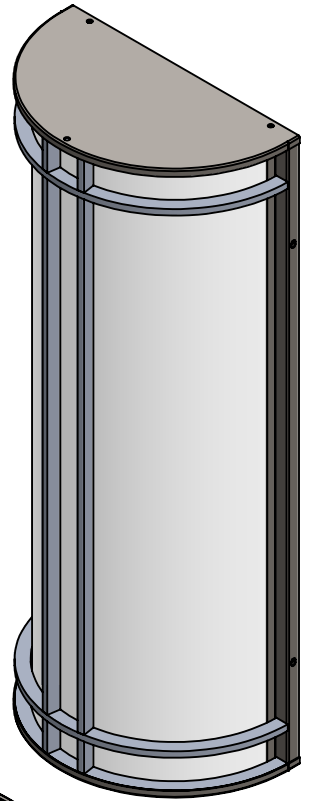
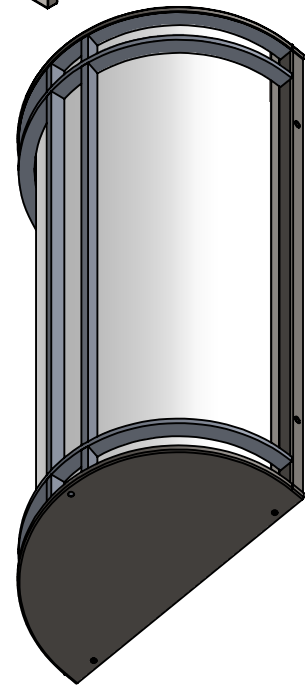
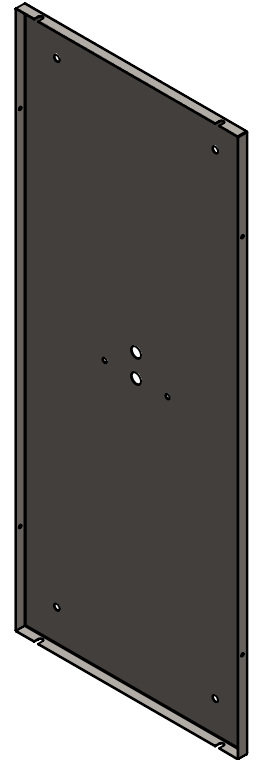
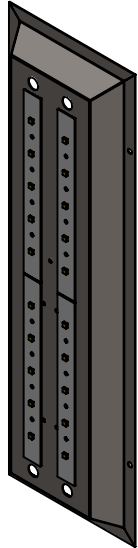
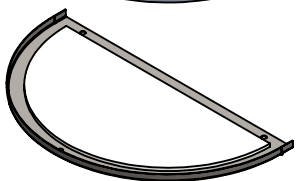
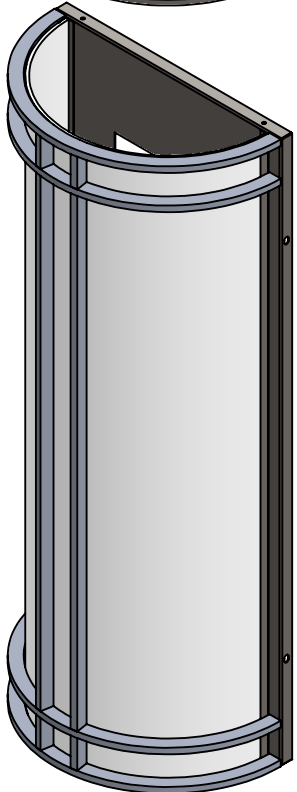
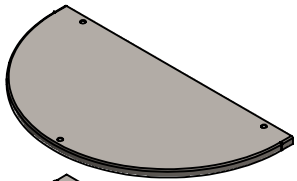
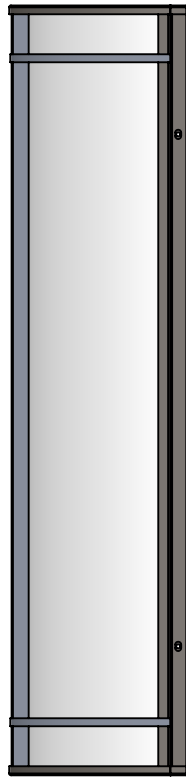
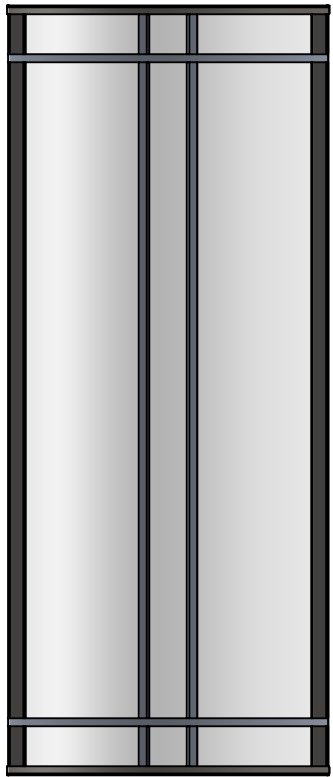

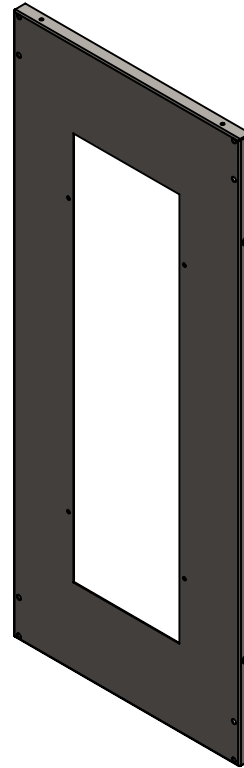
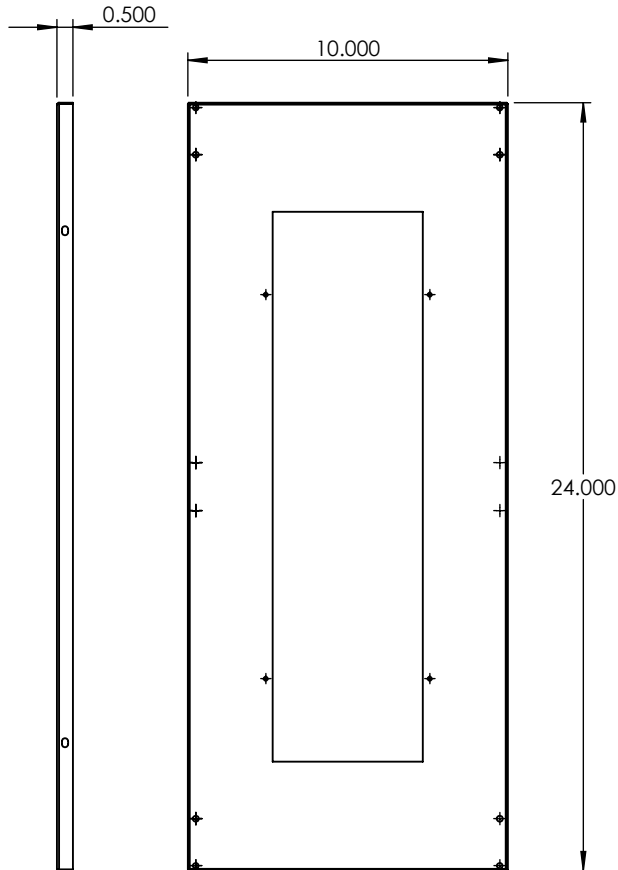
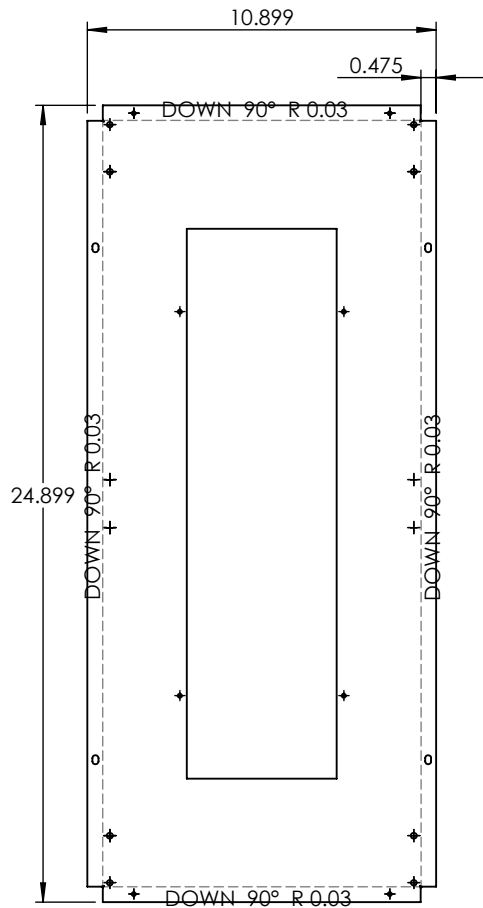

22 GAUGE

PROPRIETARY AND CONFIDENTIAL
 THE INFORMATION CONTAINED IN THIS DRAWING IS THE SOLE PROPERTY OF <INSERT COMPANY NAME HERE>. ANY REPRODUCTION IN PART OR AS A WHOLE WITHOUT THE WRITTEN PERMISSION OF <INSERT COMPANY NAME HERE> IS PROHIBITED.

		UNLESS OTHERWISE SPECIFIED:	NAME	DATE
		DIMENSIONS ARE IN INCHES	DRAWN	
		TOLERANCES:	CHECKED	
		FRACTIONAL ±	ENG APPR.	
		ANGULAR: MACH ± BEND ±	MFG APPR.	
		TWO PLACE DECIMAL ±	Q.A.	
		THREE PLACE DECIMAL ±	COMMENTS:	
		INTERPRET GEOMETRIC TOLERANCING PER:		
		MATERIAL		
NEXT ASSY	USED ON	FINISH		
APPLICATION		DO NOT SCALE DRAWING		

TITLE:
 GEO-W-24-20W-AB-WF-STB-WET-CSM-41K

SIZE	DWG. NO.	REV
A		
SCALE: 1:6	WEIGHT:	SHEET 3 OF 6

5

4

3

2

1

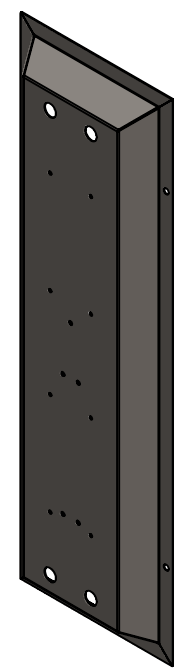
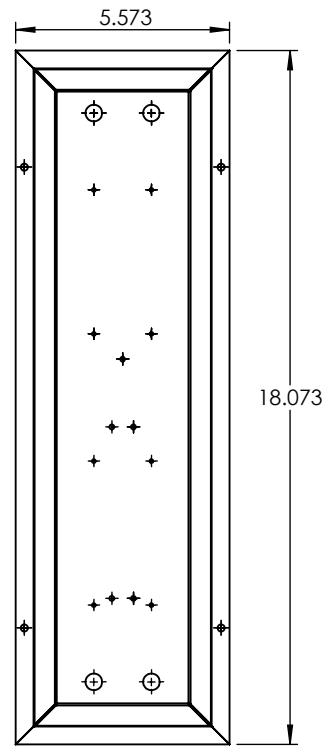
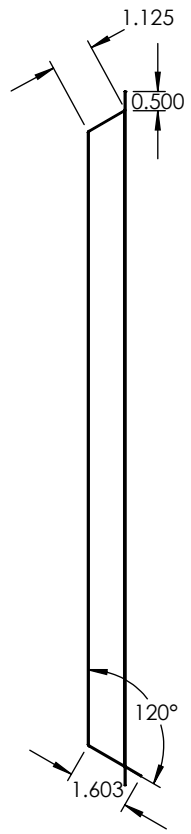
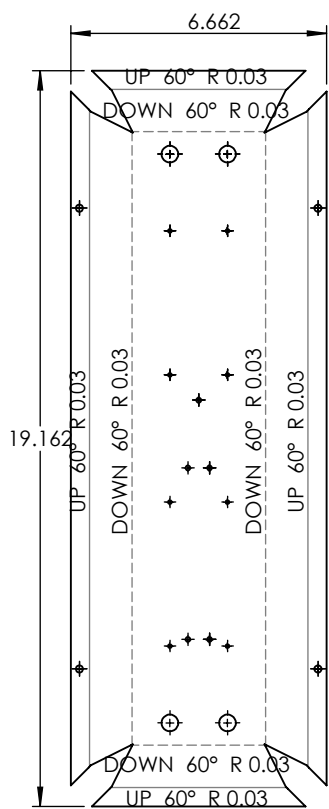

PROPRIETARY AND CONFIDENTIAL
 THE INFORMATION CONTAINED IN THIS DRAWING IS THE SOLE PROPERTY OF <INSERT COMPANY NAME HERE>. ANY REPRODUCTION IN PART OR AS A WHOLE WITHOUT THE WRITTEN PERMISSION OF <INSERT COMPANY NAME HERE> IS PROHIBITED.

		UNLESS OTHERWISE SPECIFIED:	NAME	DATE
		DIMENSIONS ARE IN INCHES TOLERANCES: FRACTIONAL ± ANGULAR: MACH ± BEND ± TWO PLACE DECIMAL ± THREE PLACE DECIMAL ±	DRAWN	
		INTERPRET GEOMETRIC TOLERANCING PER:	CHECKED	
		MATERIAL	ENG APPR.	
		FINISH	MFG APPR.	
			Q.A.	
			COMMENTS:	
NEXT ASSY	USED ON			
APPLICATION	DO NOT SCALE DRAWING			

22 GAUGE		
TITLE:		
GEO-W-24-20W-AB-WF-STB-WET-CSM-41K		
SIZE	DWG. NO.	REV
A		
SCALE: 1:5	WEIGHT:	SHEET 4 OF 6

5

4

3

2

1

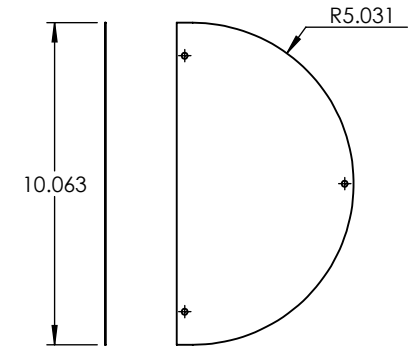
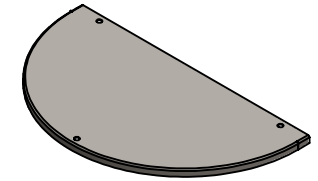
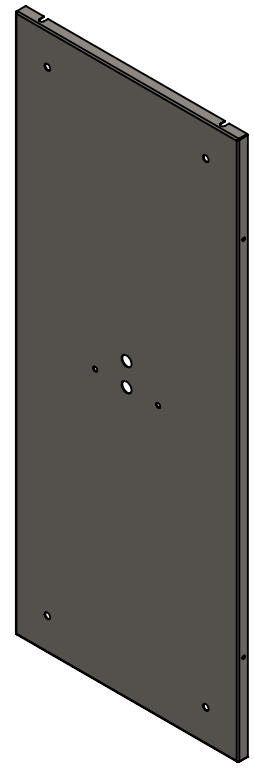
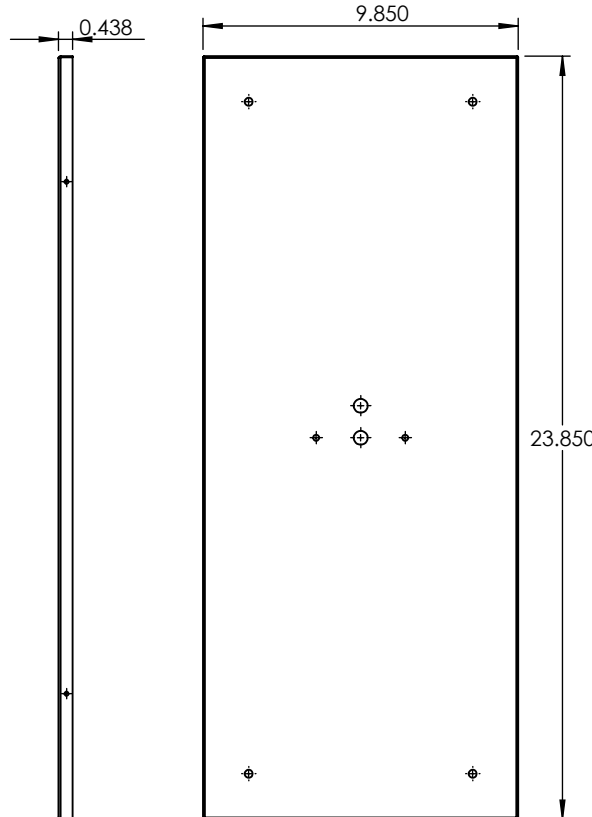
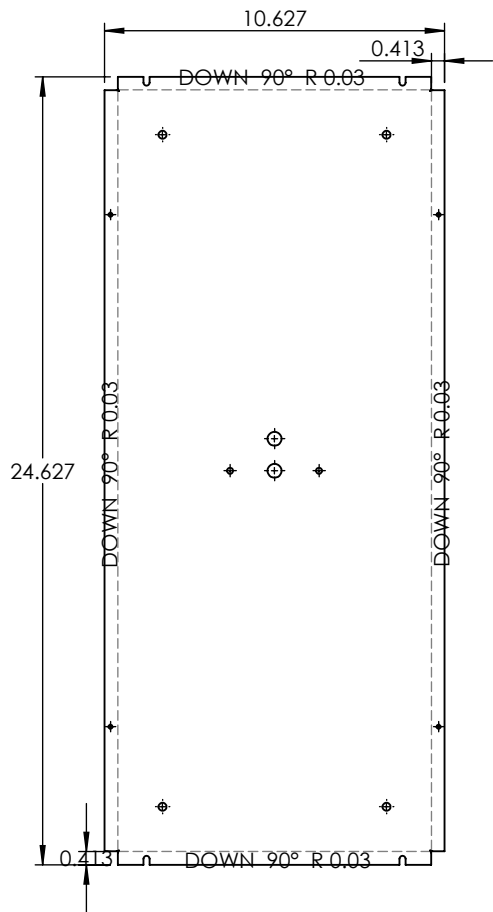

PROPRIETARY AND CONFIDENTIAL
 THE INFORMATION CONTAINED IN THIS DRAWING IS THE SOLE PROPERTY OF <INSERT COMPANY NAME HERE>. ANY REPRODUCTION IN PART OR AS A WHOLE WITHOUT THE WRITTEN PERMISSION OF <INSERT COMPANY NAME HERE> IS PROHIBITED.

		UNLESS OTHERWISE SPECIFIED:		NAME	DATE	22 GAUGE	
		DIMENSIONS ARE IN INCHES TOLERANCES: FRACTIONAL ± ANGULAR: MACH ± BEND ± TWO PLACE DECIMAL ± THREE PLACE DECIMAL ±		DRAWN			
		INTERPRET GEOMETRIC TOLERANCING PER:		CHECKED		GEO-W-24-20W-AB-WF-STB-WET-CSM-41K	
		MATERIAL		ENG APPR.			
		FINISH		MFG APPR.		SIZE DWG. NO. REV	
NEXT ASSY	USED ON			Q.A.		SCALE: 1:6 WEIGHT: SHEET 5 OF 6	
APPLICATION		DO NOT SCALE DRAWING		COMMENTS:			

5

4

3

2

1

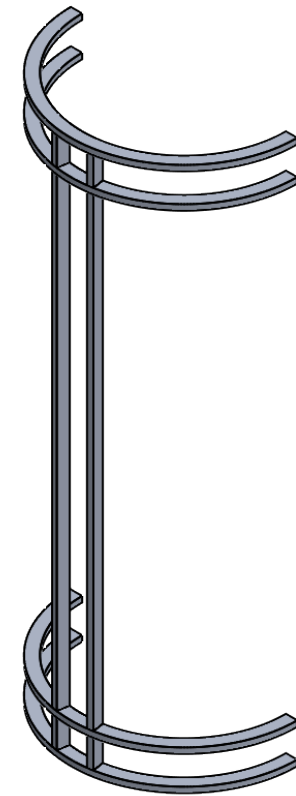
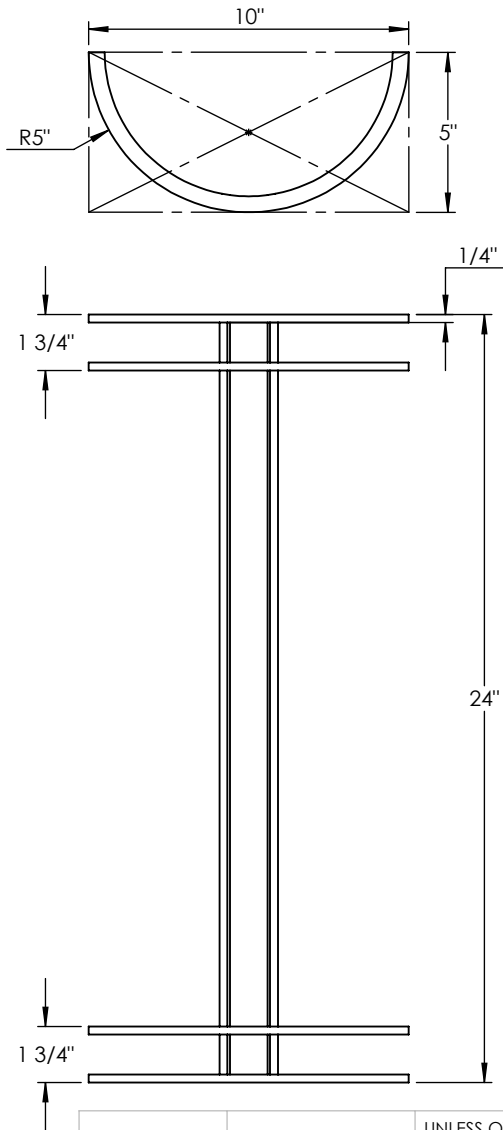

PROPRIETARY AND CONFIDENTIAL
 THE INFORMATION CONTAINED IN THIS DRAWING IS THE SOLE PROPERTY OF <INSERT COMPANY NAME HERE>. ANY REPRODUCTION IN PART OR AS A WHOLE WITHOUT THE WRITTEN PERMISSION OF <INSERT COMPANY NAME HERE> IS PROHIBITED.

		UNLESS OTHERWISE SPECIFIED:		NAME	DATE
		DIMENSIONS ARE IN INCHES	DRAWN		
		TOLERANCES:	CHECKED		
		FRACTIONAL ±	ENG APPR.		
		ANGULAR: MACH ± BEND ±	MFG APPR.		
		TWO PLACE DECIMAL ±	Q.A.		
		THREE PLACE DECIMAL ±	COMMENTS:		
		INTERPRET GEOMETRIC TOLERANCING PER:			
		MATERIAL			
		FINISH			
NEXT ASSY	USED ON				
APPLICATION		DO NOT SCALE DRAWING			

1/2"X1/4" ALUMINUM BAR		
TITLE:		
GEO-W-24-20W-AB-WF-STB-WET-CSM-41K		
SIZE	DWG. NO.	REV
A		
SCALE: 1:6	WEIGHT:	SHEET 6 OF 6