

ITEM NO.	PART NUMBER	DESCRIPTION	QTY.	CUT
1	COL-B-36-24W-TBR-WF-LSR4V-41K-CYLINDER POST	4" ALUMINUM POST	1	
2	COL-B-36-24W-TBR-WF-LSR4V-41K-ANCHOR PLATE .500"	ALUMINUM 0.500" PLATE	1	
3	COL-B-36-24W-TBR-WF-LSR4V-41K-POST BRACKET	ALUMINUM 0.250" PLATE	1	
4	COL-B-36-24W-TBR-WF-LSR4V-41K-POST FLANGE	ALUMINUM 0.250" PLATE	1	
5	COL-B-36-24W-TBR-WF-LSR4V-41K-SQUARE CAP	ALUMINUM 0.0635"	1	
6	COL-B-36-24W-TBR-WF-LSR4V-41K-SQUARE INNER CAP	ALUMINUM 0.0635"	1	
7	COL-B-36-24W-TBR-WF-LSR4V-41K-TUBE BRACKET	ALUMINUM 0.0635"	1	
8	COL-B-36-24W-TBR-WF-LSR4V-41K-DRIVER BRACKET	ALUMINUM 0.0635"	1	
9	COL-B-36-24W-TBR-WF-LSR4V-41K-ANCHOR PLATE COVER	ALUMINUM 0.0635"	2	
10	COL-B-36-24W-TBR-WF-LSR4V-41K-ANCHOR BRACKET	ALUMINUM 0.0635"	2	
11	COL-B-36-24W-TBR-WF-LSR4V-41K-SLEEVE SIDE	ALUMINUM 0.0635"	2	
12	COL-B-36-24W-TBR-WF-LSR4V-41K-SLOT SHIELD SIDE	ALUMINUM 0.0635"	2	
13	COL-B-36-24W-TBR-WF-LSR4V-41K-SQUARE LED TUBE	1" ALUMINUM TUBE	1	
14	COL-B-36-24W-TBR-WF-LSR4V-41K-ACRYLIC	ACRYLIC	1	
15	ESPEN VEL29070MVH-1	DRIVER	1	
19	Alttailed PN1010 RevD	LED	4	

UNLESS OTHERWISE SPECIFIED:

DIMENSIONS ARE IN INCHES
 TOLERANCES:
 FRACTIONAL ± .003
 ANGULAR: MACH ± .01 BEND ±
 TWO PLACE DECIMAL ±
 THREE PLACE DECIMAL ±.001

INTERPRET GEOMETRIC
 TOLERANCING PER:

MATERIAL

FINISH

	NAME	DATE
DRAWN		
CHECKED		
ENG APPR.		
MFG APPR.		
Q.A.		

COMMENTS:

TITLE:

COL-B-36-24W-TBR-WF-LSR4V-41K

SIZE DWG. NO. REV
A TICKET 26007

SCALE: 1:10 WEIGHT: SHEET 1 OF 12



ALL BEND RADIUS .030"

APPLICATION

DO NOT SCALE DRAWING

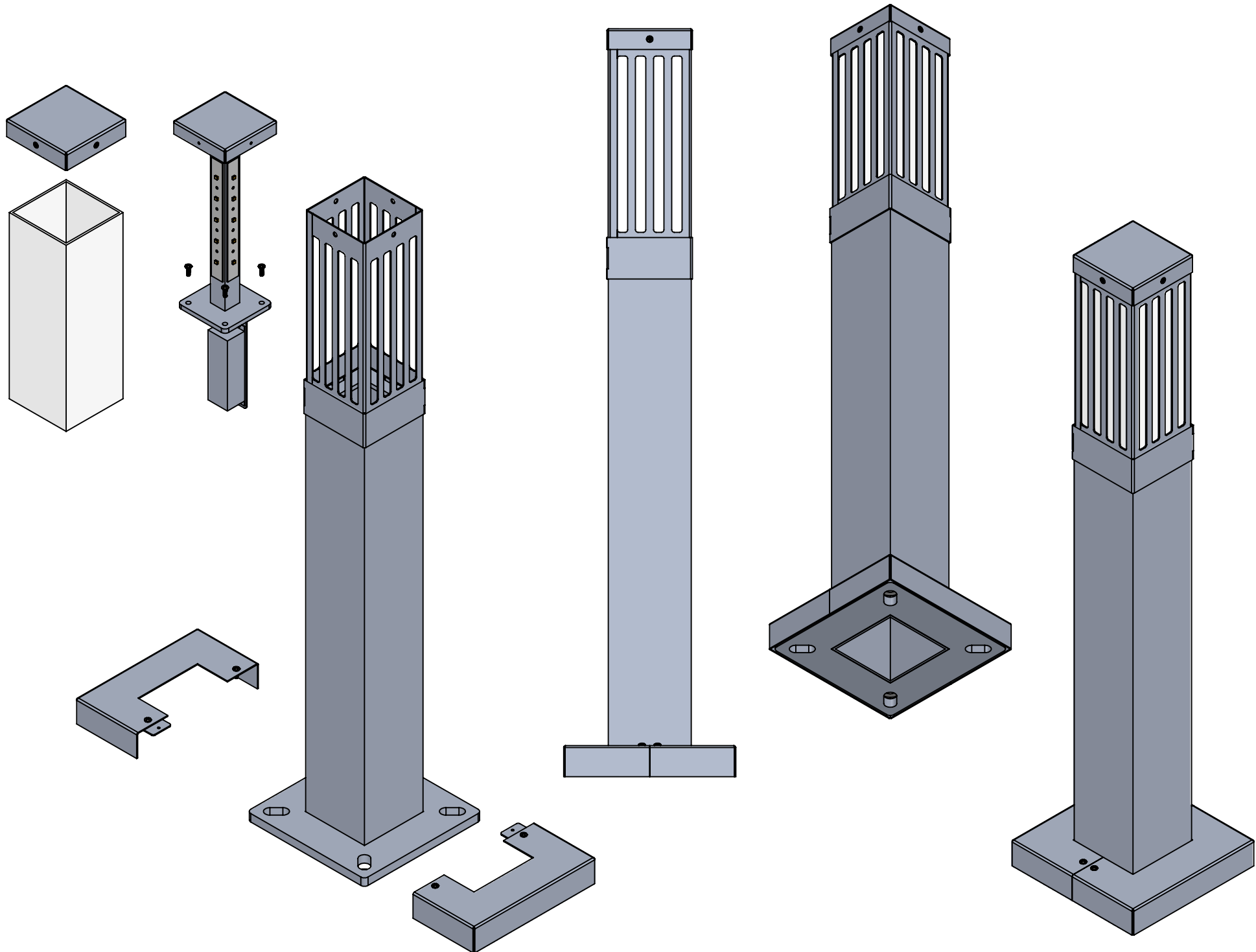

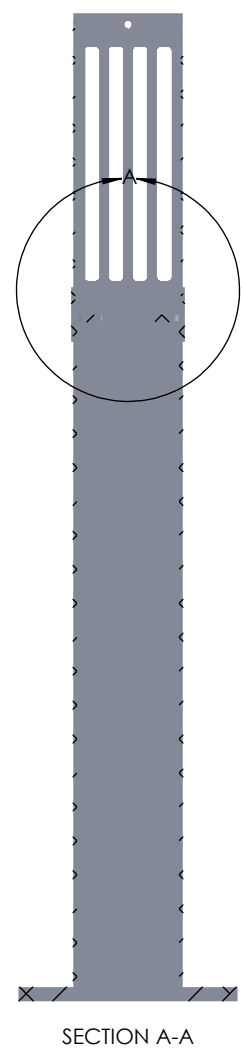
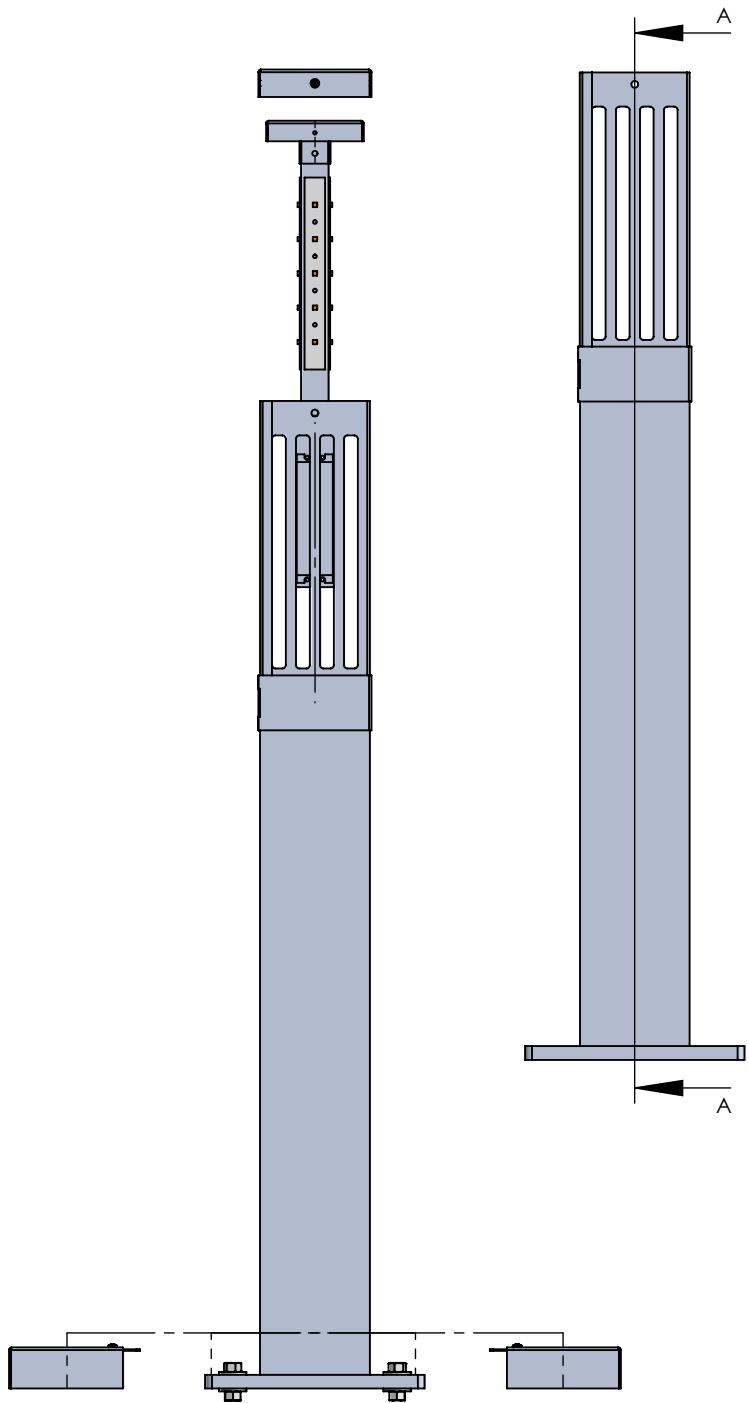
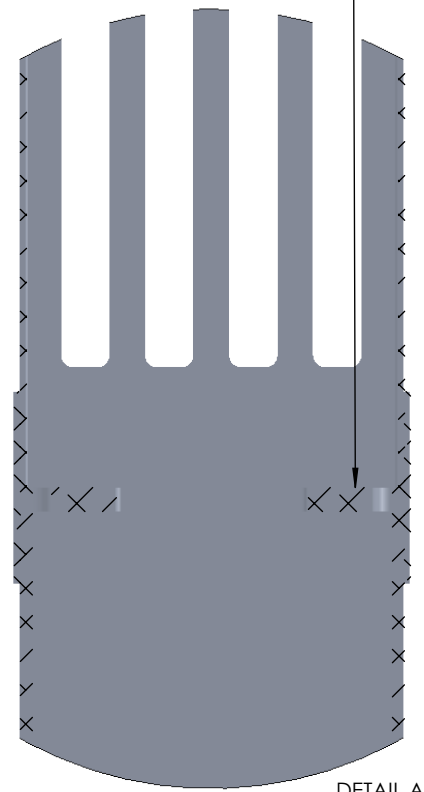
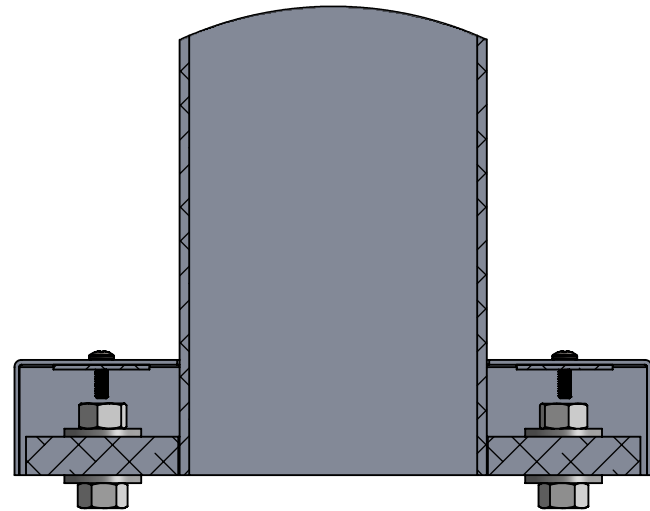
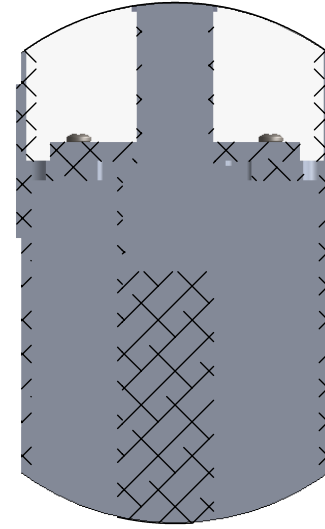
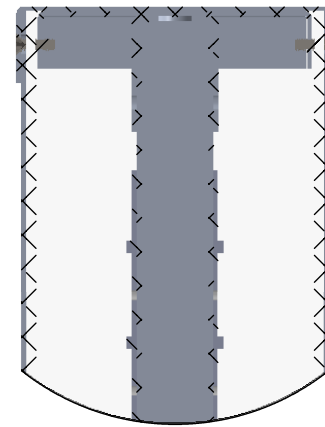
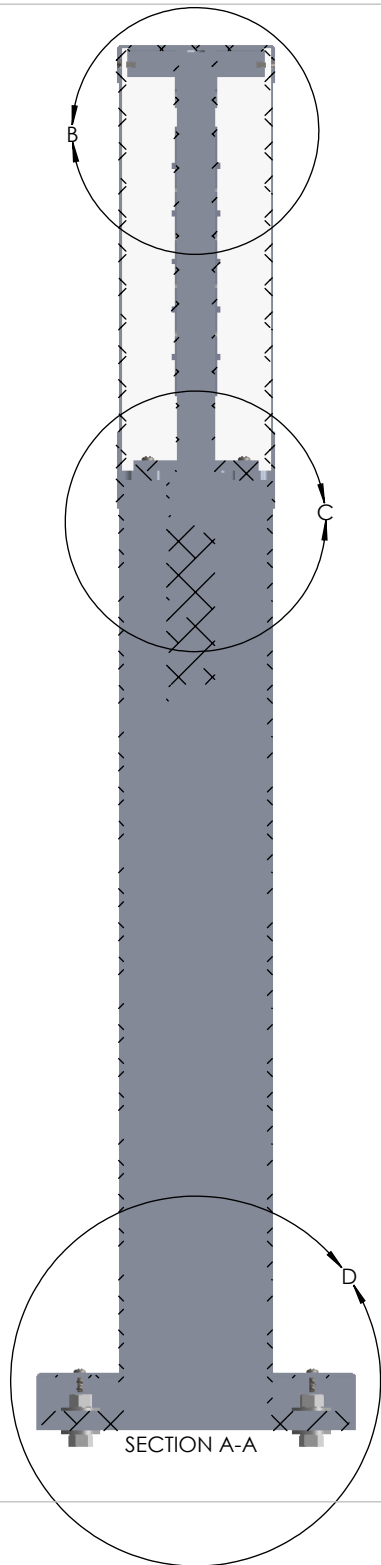
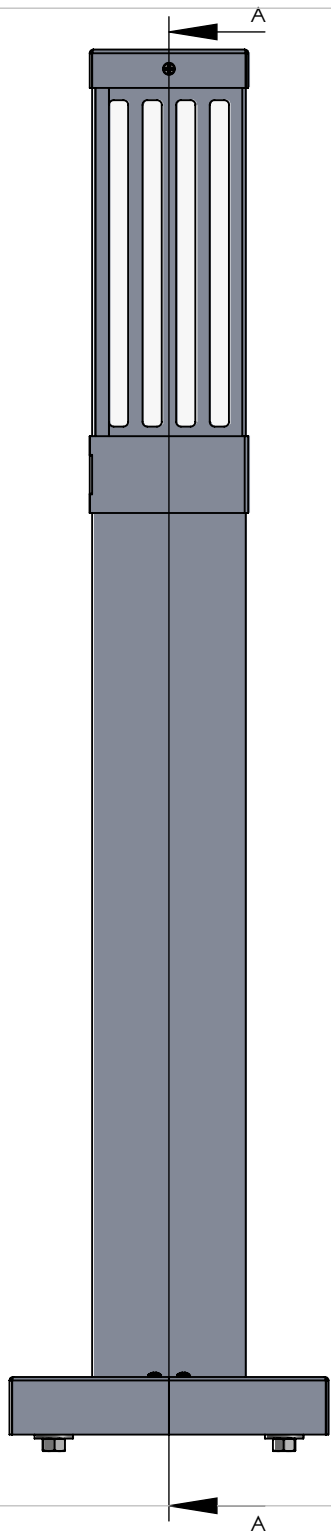
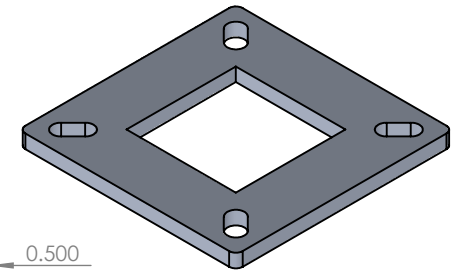
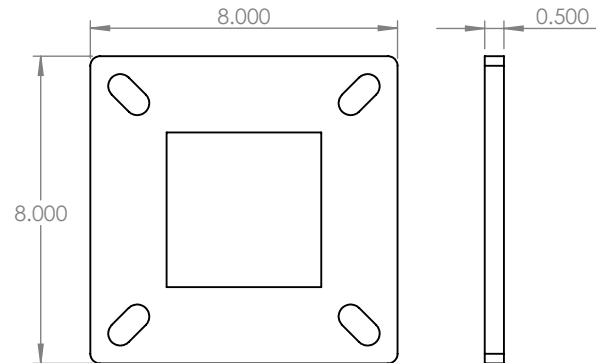
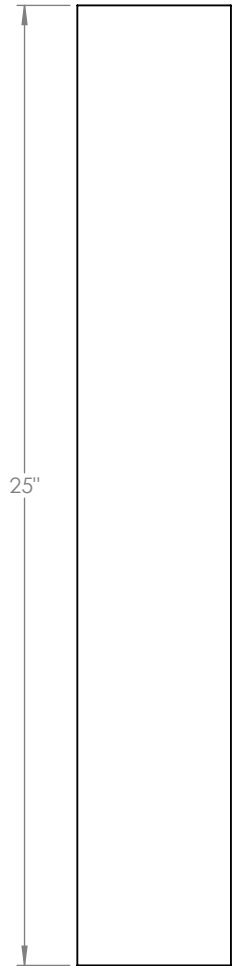
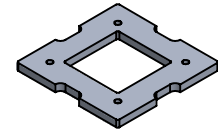
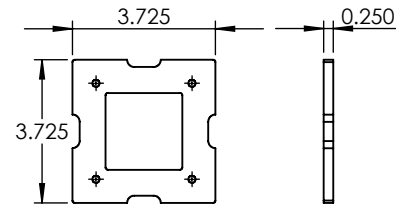
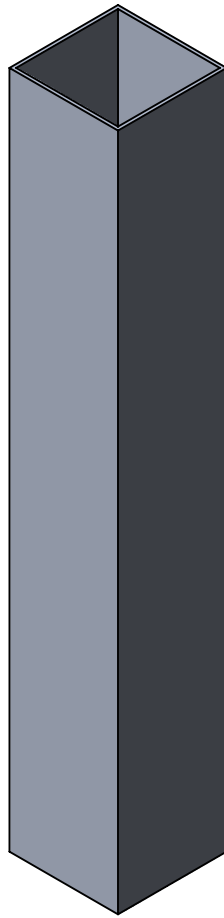
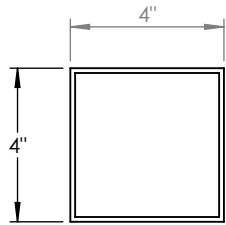

PLATE IS FLUSH WITH SURFACE
OD BOLLARD TUBE







PROPRIETARY AND CONFIDENTIAL
 THE INFORMATION CONTAINED IN THIS DRAWING IS THE SOLE PROPERTY OF <INSERT COMPANY NAME HERE>. ANY REPRODUCTION IN PART OR AS A WHOLE WITHOUT THE WRITTEN PERMISSION OF <INSERT COMPANY NAME HERE> IS PROHIBITED.

NEXT ASSY	USED ON
APPLICATION	

UNLESS OTHERWISE SPECIFIED:
 DIMENSIONS ARE IN INCHES
 TOLERANCES:
 FRACTIONAL ±
 ANGULAR: MACH ± BEND ±
 TWO PLACE DECIMAL ±
 THREE PLACE DECIMAL ±

INTERPRET GEOMETRIC TOLERANCING PER:
 MATERIAL
 FINISH
 DO NOT SCALE DRAWING

	NAME	DATE
DRAWN		
CHECKED		
ENG APPR.		
MFG APPR.		

Q.A.
 COMMENTS:

ALUMINUM 0.500" PLATE		
TITLE:		
COL-B-36-24W-TBR-WF-LSR4V-41K		
SIZE	DWG. NO.	REV
A		
SCALE: 1:5	WEIGHT:	SHEET 5 OF 12

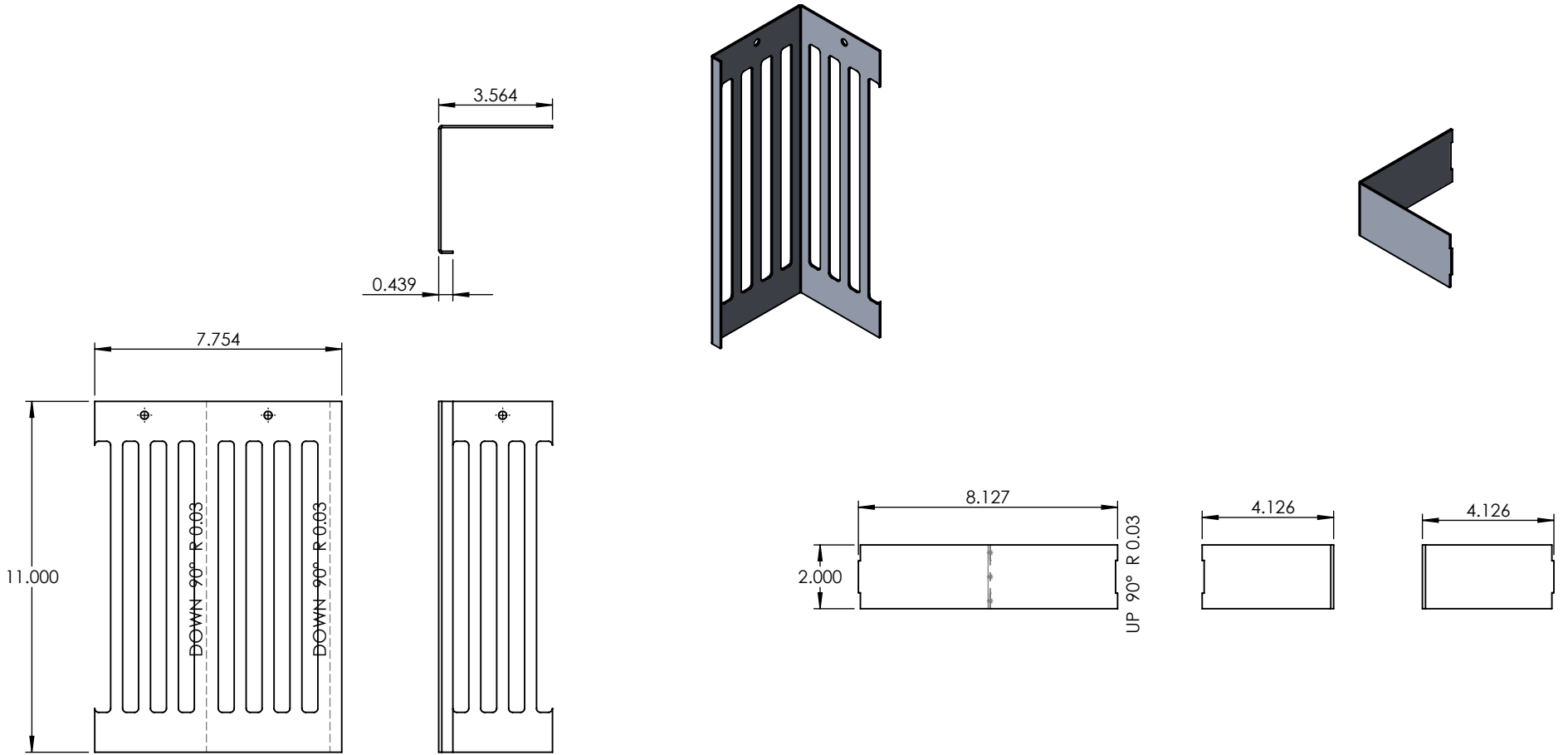

PROPRIETARY AND CONFIDENTIAL
 THE INFORMATION CONTAINED IN THIS DRAWING IS THE SOLE PROPERTY OF <INSERT COMPANY NAME HERE>. ANY REPRODUCTION IN PART OR AS A WHOLE WITHOUT THE WRITTEN PERMISSION OF <INSERT COMPANY NAME HERE> IS PROHIBITED.

		UNLESS OTHERWISE SPECIFIED:		NAME	DATE	22 GAUGE	
		DIMENSIONS ARE IN INCHES TOLERANCES: FRACTIONAL ± ANGULAR: MACH ± BEND ± TWO PLACE DECIMAL ± THREE PLACE DECIMAL ±	DRAWN				
		INTERPRET GEOMETRIC TOLERANCING PER:	CHECKED			SIZE DWG. NO. REV	
		MATERIAL	ENG APPR.				
NEXT ASSY	USED ON	FINISH	MFG APPR.			SCALE: 1:5 WEIGHT: SHEET 6 OF 12	
APPLICATION		DO NOT SCALE DRAWING	Q.A.				
			COMMENTS:				

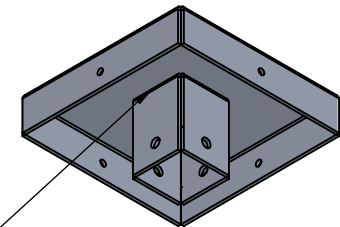
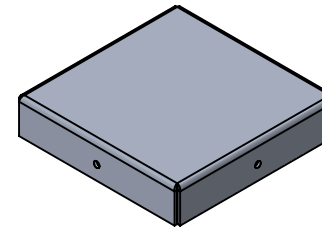
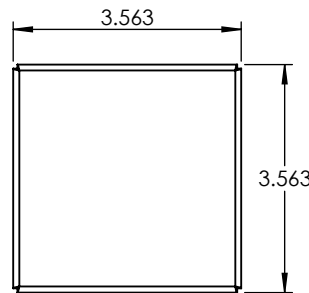
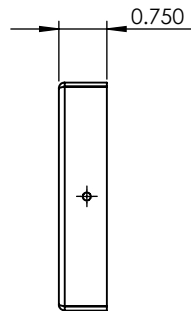
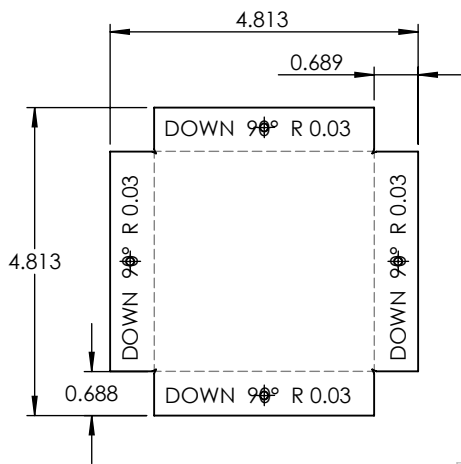
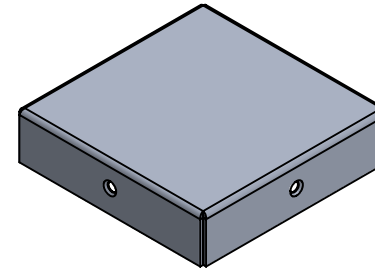
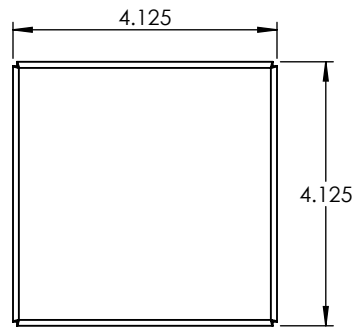
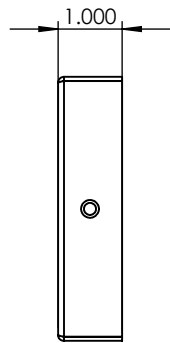
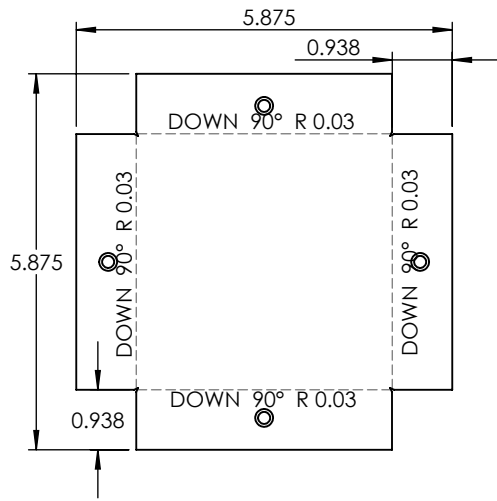

TUBE BRACKET WELDED TO INNER CAP

PROPRIETARY AND CONFIDENTIAL
 THE INFORMATION CONTAINED IN THIS DRAWING IS THE SOLE PROPERTY OF <INSERT COMPANY NAME HERE>. ANY REPRODUCTION IN PART OR AS A WHOLE WITHOUT THE WRITTEN PERMISSION OF <INSERT COMPANY NAME HERE> IS PROHIBITED.

		UNLESS OTHERWISE SPECIFIED:	NAME	DATE	ALUMINUM 0.0635"	
		DIMENSIONS ARE IN INCHES	DRAWN		TITLE:	
		TOLERANCES:	CHECKED		COL-B-36-24W-TBR-WF-LSR4V-41K	
		FRACTIONAL ±	ENG APPR.		SIZE DWG. NO. REV	
		ANGULAR: MACH ± BEND ±	MFG APPR.		SCALE: 1:3 WEIGHT: SHEET 7 OF 12	
		TWO PLACE DECIMAL ±	Q.A.			
		THREE PLACE DECIMAL ±	COMMENTS:			
		INTERPRET GEOMETRIC TOLERANCING PER:				
		MATERIAL				
	NEXT ASSY	FINISH				
	USED ON	DO NOT SCALE DRAWING				
	APPLICATION					

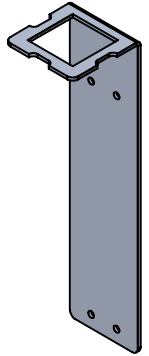
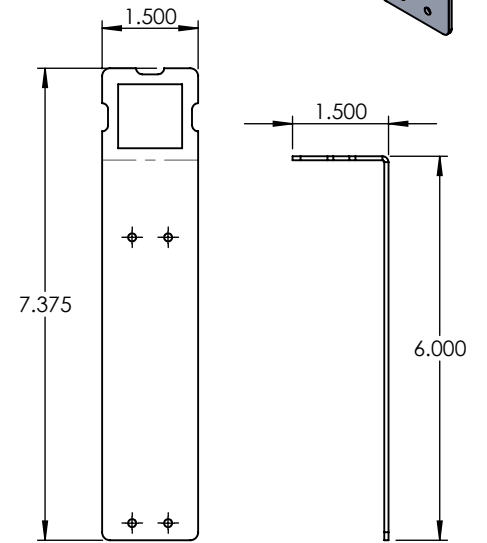
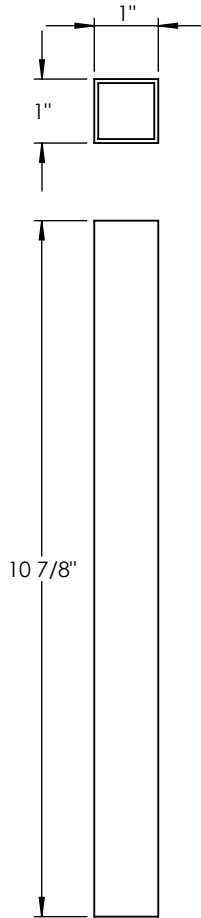
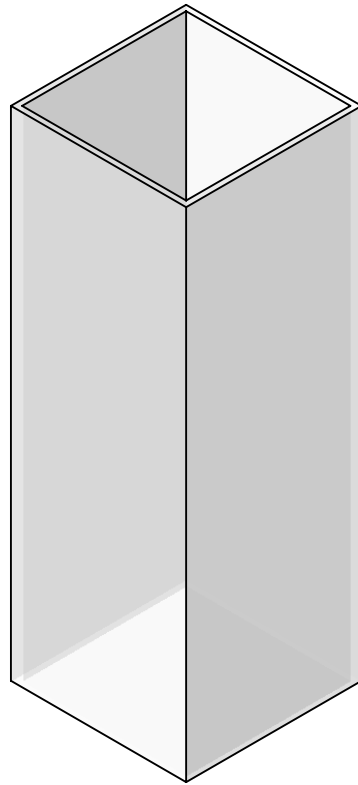
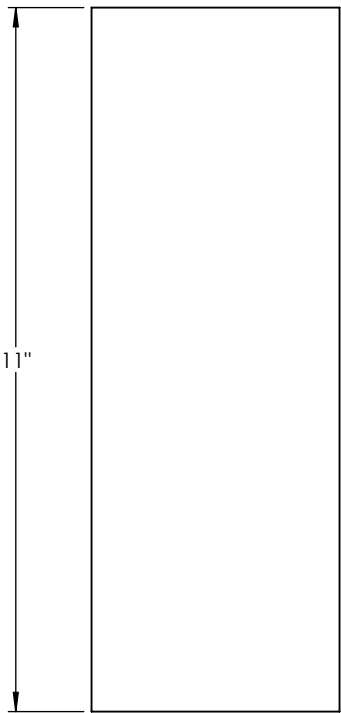
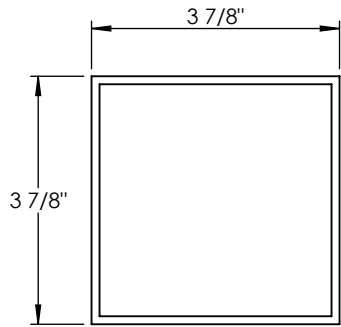

PROPRIETARY AND CONFIDENTIAL
 THE INFORMATION CONTAINED IN THIS DRAWING IS THE SOLE PROPERTY OF <INSERT COMPANY NAME HERE>. ANY REPRODUCTION IN PART OR AS A WHOLE WITHOUT THE WRITTEN PERMISSION OF <INSERT COMPANY NAME HERE> IS PROHIBITED.

NEXT ASSY	USED ON
APPLICATION	

UNLESS OTHERWISE SPECIFIED:
DIMENSIONS ARE IN INCHES
TOLERANCES:
FRACTIONAL ±
ANGULAR: MACH ± BEND ±
TWO PLACE DECIMAL ±
THREE PLACE DECIMAL ±
INTERPRET GEOMETRIC TOLERANCING PER:
MATERIAL
FINISH
DO NOT SCALE DRAWING

NAME	DATE
DRAWN	
CHECKED	
ENG APPR.	
MFG APPR.	
Q.A.	
COMMENTS:	

ACRYLIC		
TITLE:		
COL-B-36-24W-TBR-WF-LSR4V-41K		
SIZE	DWG. NO.	REV
A		
SCALE: 1:3	WEIGHT:	SHEET 8 OF 12

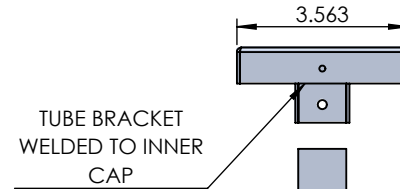
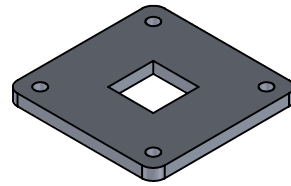
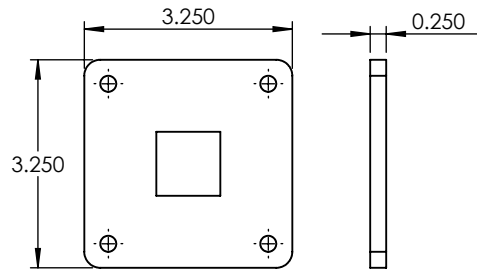

TUBE BRACKET
WELDED TO INNER
CAP

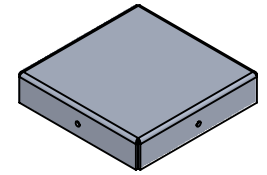

SQUARE TUBE
WELDED TO PLATE

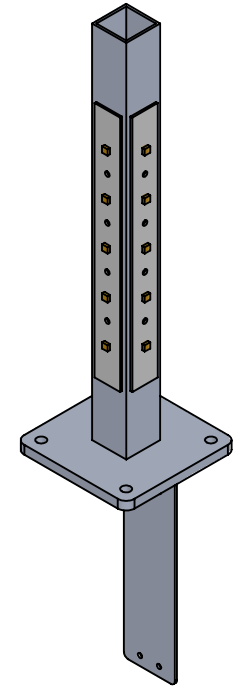
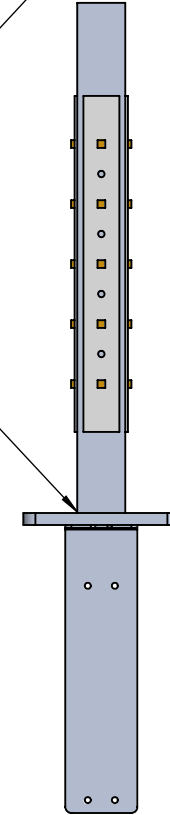

TUBE BRACKET
WELDED TO PLATE

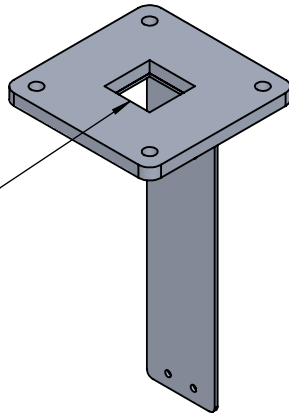

TUBE BRACKET WELDED
TO INNER CAP

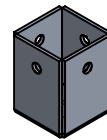
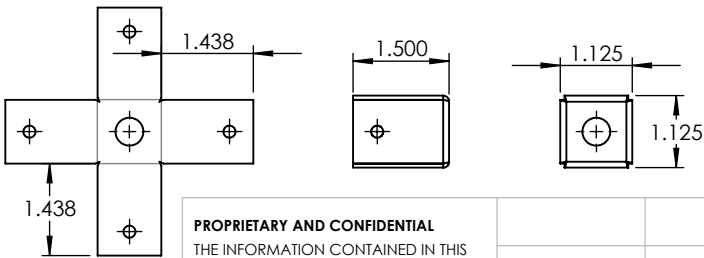
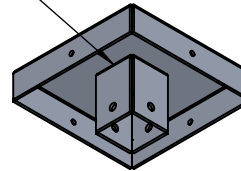

UNLESS OTHERWISE SPECIFIED:

DIMENSIONS ARE IN INCHES
TOLERANCES:
FRACTIONAL ±
ANGULAR: MACH ± BEND ±
TWO PLACE DECIMAL ±
THREE PLACE DECIMAL ±

INTERPRET GEOMETRIC
TOLERANCING PER:

MATERIAL

FINISH

DO NOT SCALE DRAWING

NAME

DATE

DRAWN

CHECKED

ENG APPR.

MFG APPR.

Q.A.

COMMENTS:

ALUMINUM 0.0635"

TITLE:

COL-B-36-24W-TBR-WF-LSR4V-41K

SIZE
A

DWG. NO.

REV

SCALE: 1:3

WEIGHT:

SHEET 9 OF 12

PROPRIETARY AND CONFIDENTIAL
THE INFORMATION CONTAINED IN THIS
DRAWING IS THE SOLE PROPERTY OF
<INSERT COMPANY NAME HERE>. ANY
REPRODUCTION IN PART OR AS A WHOLE
WITHOUT THE WRITTEN PERMISSION OF
<INSERT COMPANY NAME HERE> IS
PROHIBITED.

NEXT ASSY

USED ON

APPLICATION

5

4

3

2

1

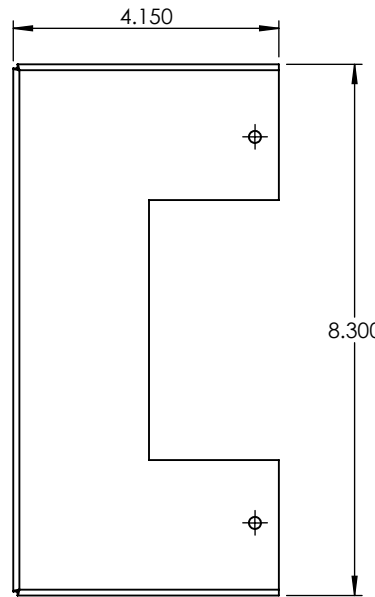
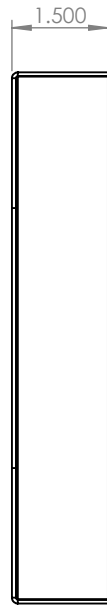
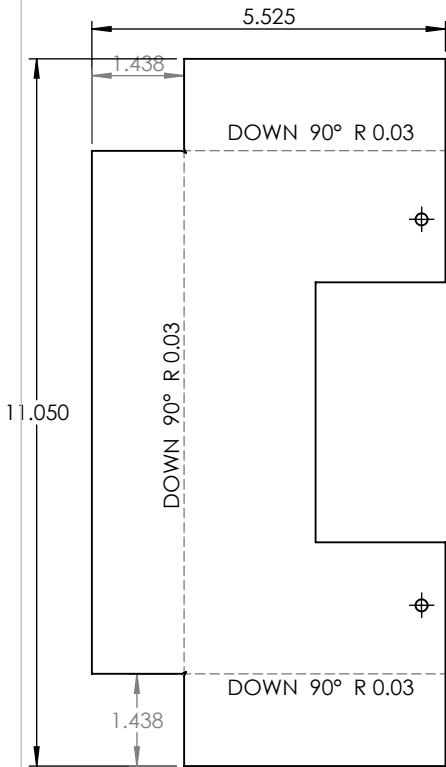
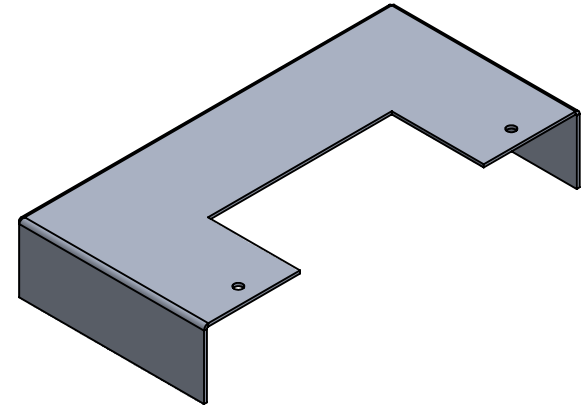
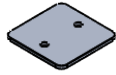
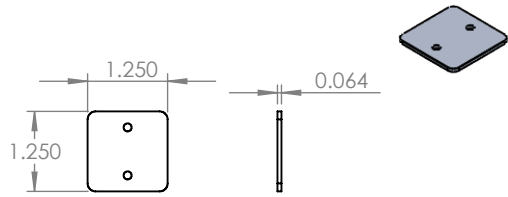

PROPRIETARY AND CONFIDENTIAL
 THE INFORMATION CONTAINED IN THIS DRAWING IS THE SOLE PROPERTY OF <INSERT COMPANY NAME HERE>. ANY REPRODUCTION IN PART OR AS A WHOLE WITHOUT THE WRITTEN PERMISSION OF <INSERT COMPANY NAME HERE> IS PROHIBITED.

		UNLESS OTHERWISE SPECIFIED:	NAME	DATE	ALUMINUM 0.0635"	
		DIMENSIONS ARE IN INCHES	DRAWN		TITLE:	
		TOLERANCES:	CHECKED		COL-B-36-24W-TBR-WF-LSR4V-41K	
		FRACTIONAL ±	ENG APPR.		SIZE DWG. NO. REV	
		ANGULAR: MACH ± BEND ±	MFG APPR.		A	
		TWO PLACE DECIMAL ±	Q.A.		SCALE: 1:3 WEIGHT: SHEET 10 OF 12	
		THREE PLACE DECIMAL ±	COMMENTS:			
		INTERPRET GEOMETRIC TOLERANCING PER:				
		MATERIAL				
NEXT ASSY	USED ON	FINISH				
APPLICATION		DO NOT SCALE DRAWING				

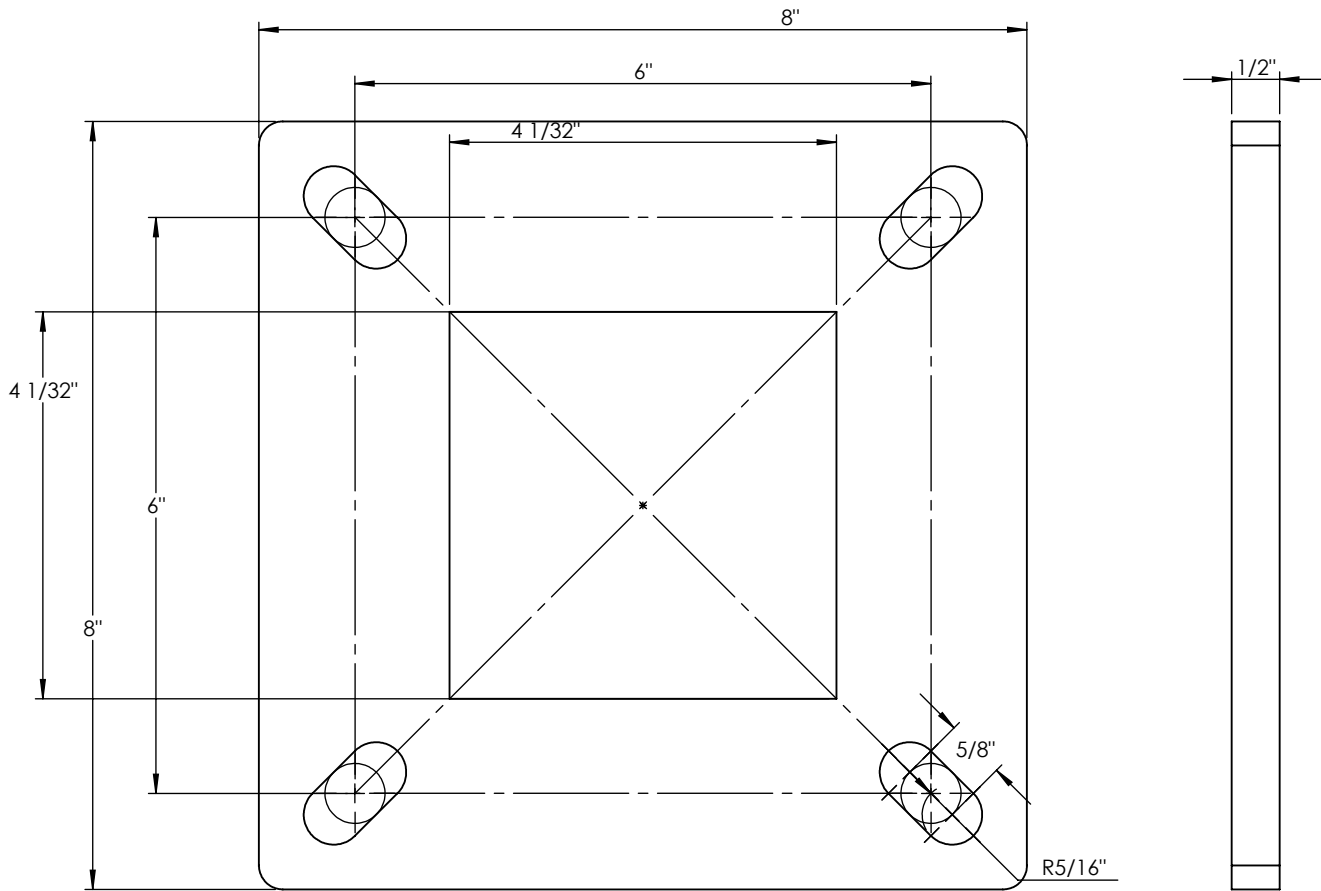

PROPRIETARY AND CONFIDENTIAL
 THE INFORMATION CONTAINED IN THIS DRAWING IS THE SOLE PROPERTY OF <INSERT COMPANY NAME HERE>. ANY REPRODUCTION IN PART OR AS A WHOLE WITHOUT THE WRITTEN PERMISSION OF <INSERT COMPANY NAME HERE> IS PROHIBITED.

		UNLESS OTHERWISE SPECIFIED:	NAME	DATE
		DIMENSIONS ARE IN INCHES	DRAWN	
		TOLERANCES:	CHECKED	
		FRACTIONAL ±	ENG APPR.	
		ANGULAR: MACH ± BEND ±	MFG APPR.	
		TWO PLACE DECIMAL ±	Q.A.	
		THREE PLACE DECIMAL ±	COMMENTS:	
		INTERPRET GEOMETRIC TOLERANCING PER:		
		MATERIAL		
NEXT ASSY	USED ON	FINISH		
APPLICATION		DO NOT SCALE DRAWING		

ALUMINUM 0.500" PLATE		
TITLE:		
COL-B-36-24W-TBR-WF-LSR4V-41K		
SIZE	DWG. NO.	REV
A		
SCALE: 1:2	WEIGHT:	SHEET 11 OF 12

