

UNLESS OTHERWISE SPECIFIED: DIMENSIONS ARE IN INCHES TOLERANCES: FRACTIONAL ± .003 ANGULAR: MACH ± .01 BEND ± TWO PLACE DECIMAL ± THREE PLACE DECIMAL ±.001 INTERPRET GEOMETRIC TOLERANCING PER: MATERIAL FINISH	NAME	DATE	TITLE:
	DRAWN		
	CHECKED		
	ENG APPR.		
	MFG APPR.		
COMMENTS:			SIZE DWG. NO. REV A TICKET 26013 SCALE: 1:10 WEIGHT: SHEET 1 OF 12



ALL BEND RADIUS .030"

APPLICATION

DO NOT SCALE DRAWING

5

4

3

2

1

ITEM NO.	PART NUMBER	DESCRIPTION	QTY.	CUT
1	VSCS-ECSTR-26"-50W-AB-WF-TBL-WET-40K-SPUN SHADE	SPUN ALUMINUM 0.080"	2	
2	VSCS-ECSTR-26"-50W-AB-WF-TBL-WET-40K-TUBE SLEEVE	SPUN ALUMINUM 0.080"	2	
3	VSCS-ECSTR-26"-50W-AB-WF-TBL-WET-40K-VERTICAL TUBE FITTER	SPUN ALUMINUM 0.080"	4	
4	VSCS-ECSTR-26"-50W-AB-WF-TBL-WET-40K-BACKPLATE	ALUMINUM 0.0635"	1	
5	VSCS-ECSTR-26"-50W-AB-WF-TBL-WET-40K-FIREPLATE	ALUMINUM 0.0635"	1	
6	VSCS-ECSTR-26"-50W-AB-WF-TBL-WET-40K-DRIVER BRACKET	ALUMINUM 0.0635"	1	
7	VSCS-ECSTR-26"-50W-AB-WF-TBL-WET-40K-FRAME SPACER	ALUMINUM 0.0635"	1	
8	VSCS-ECSTR-26"-50W-AB-WF-TBL-WET-40K-TUBE BRACKET	ALUMINUM 0.0635"	2	
9	VSCS-ECSTR-26"-50W-AB-WF-TBL-WET-40K-LED REFLECTOR	ALUMINUM 0.0635"	2	
10	VSCS-ECSTR-26"-50W-AB-WF-TBL-WET-40K-REFLECTOR BRACKET	ALUMINUM 0.0635"	2	
11	VSCS-ECSTR-26"-50W-AB-WF-TBL-WET-40K-TUBE BRACKET PLATE	ALUMINUM 0.250" PLATE	4	
12	VSCS-ECSTR-26"-50W-AB-WF-TBL-WET-40K-ACRYLIC TUBE	ACRYLIC LENS	1	
13	VSCS-ECSTR-26"-50W-AB-WF-TBL-WET-40K-BACKPLATE TAB	25 GAUGE ALUMINUM	4	
14	VSCS-ECSTR-26"-50W-AB-WF-TBL-WET-40K-SQUARE TUBE	1" SQUARE ALUMINUM TUBE	1	
15	VSCS-ECSTR-26"-50W-AB-WF-TBL-WET-40K-SQUARE ARM TUBE	2" SQUARE ALUMINUM TUBE	2	
16	VSCS-ECSTR-26"-50W-AB-WF-TBL-WET-40K-VERTICAL TUBE	1" ROUND ALUMINUM TUBE	2	
17	VSCS-ECSTR-26"-50W-AB-WF-TBL-WET-40K-NIPPLE	NIPPLE	2	
18	55MM HEXAGON HEAT SINK	HEAT SINK	2	
19	ESPEN VEL29070MVH-1	DRIVER	3	
24	Alttailed PN1010_RevD	LED	8	
25	Alttailed PCN D1500 110B-10 WATT	LED	2	

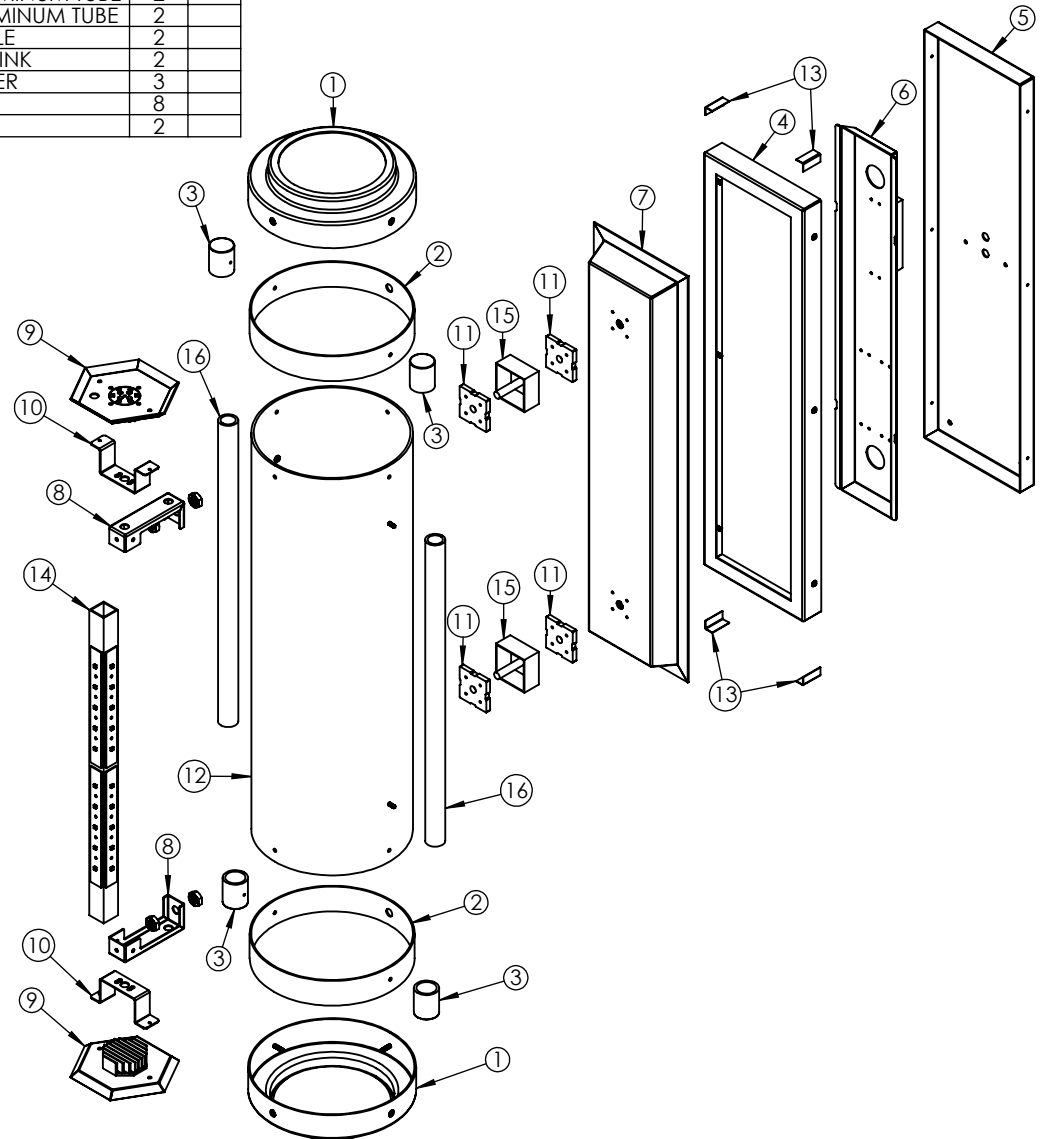

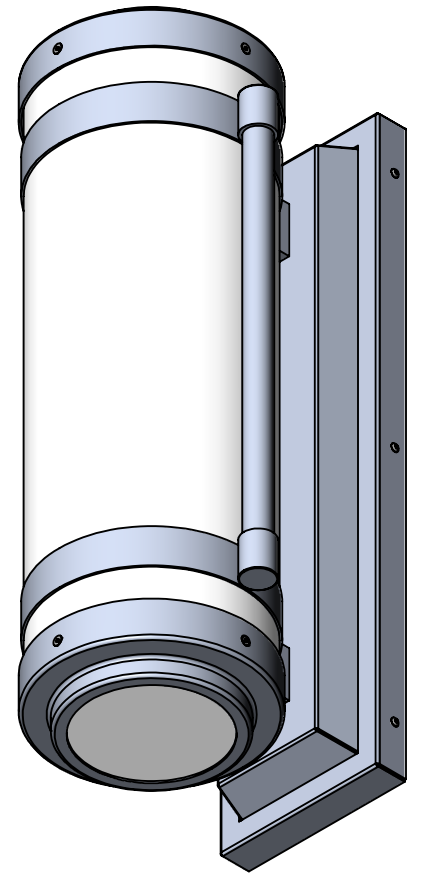
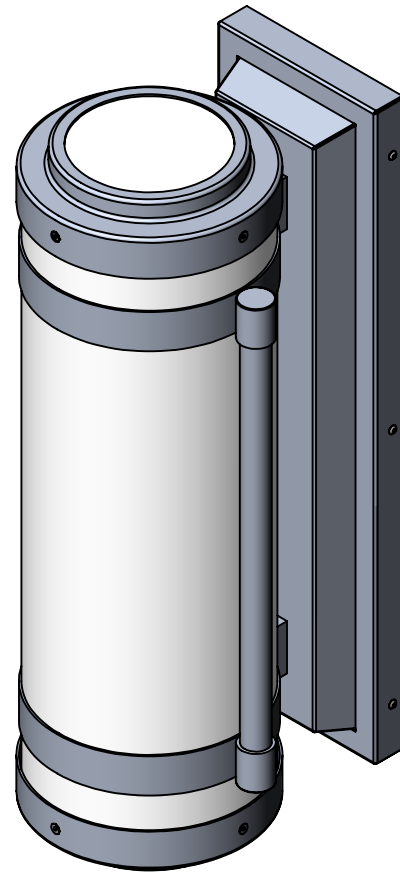
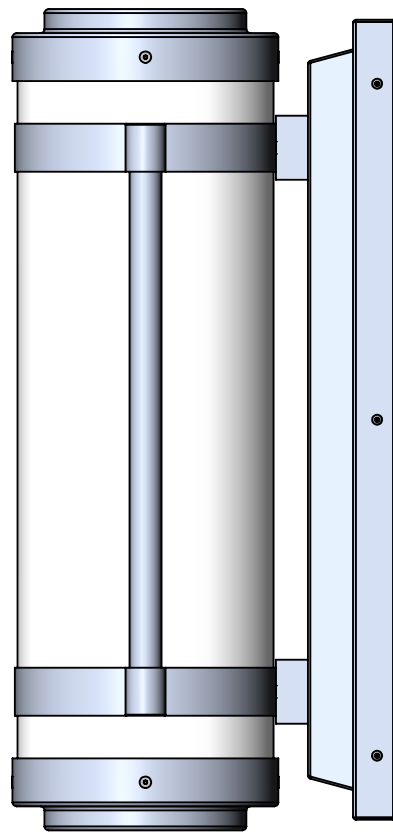
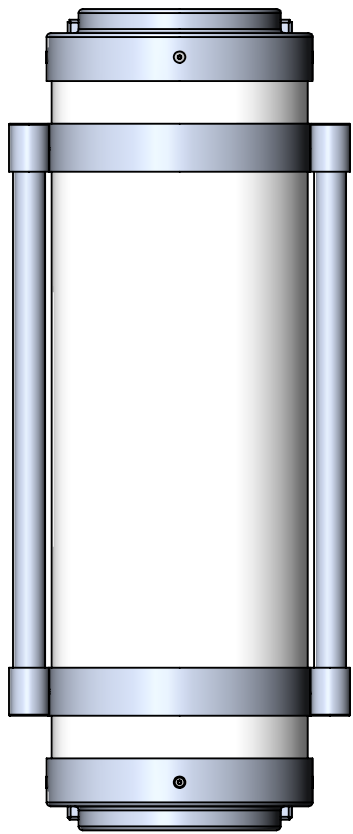

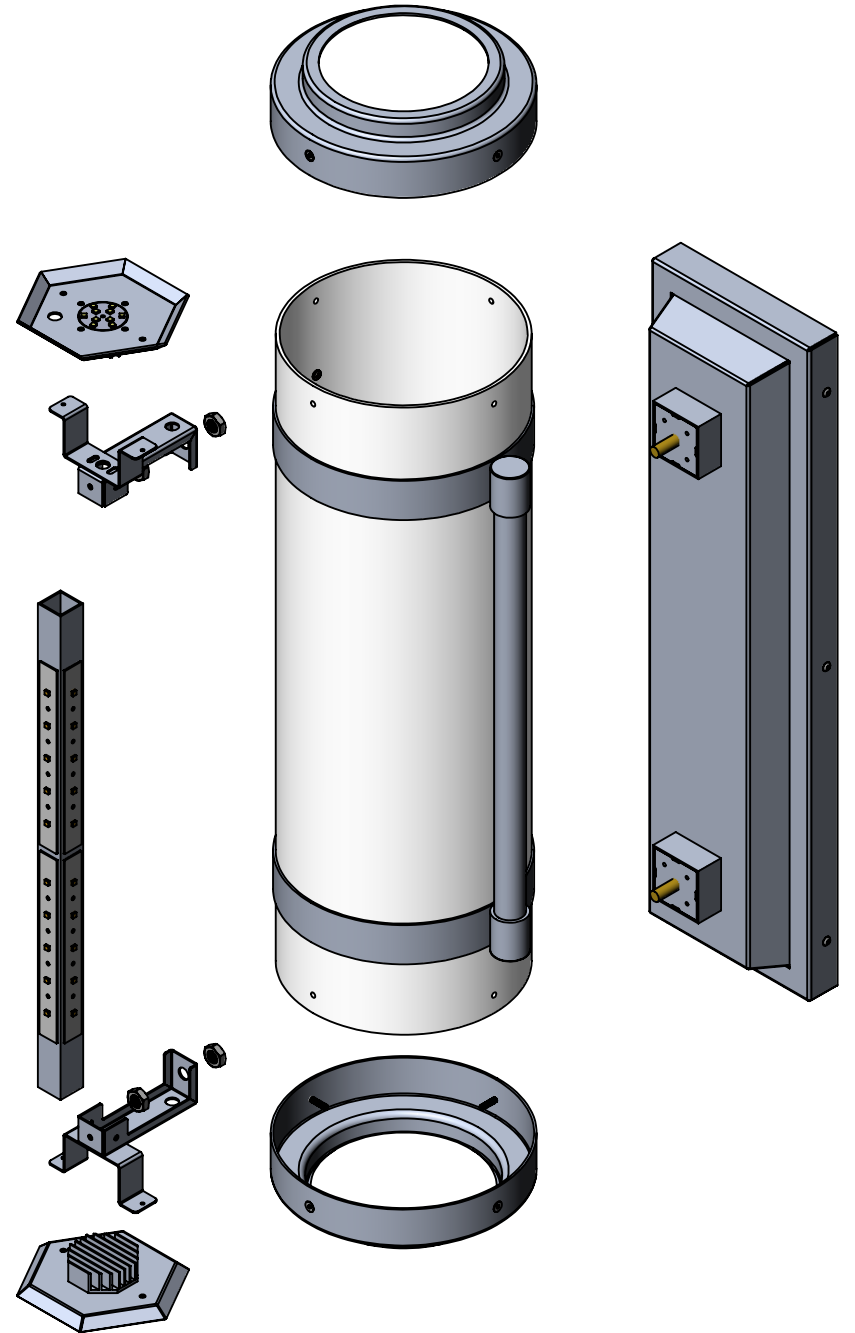
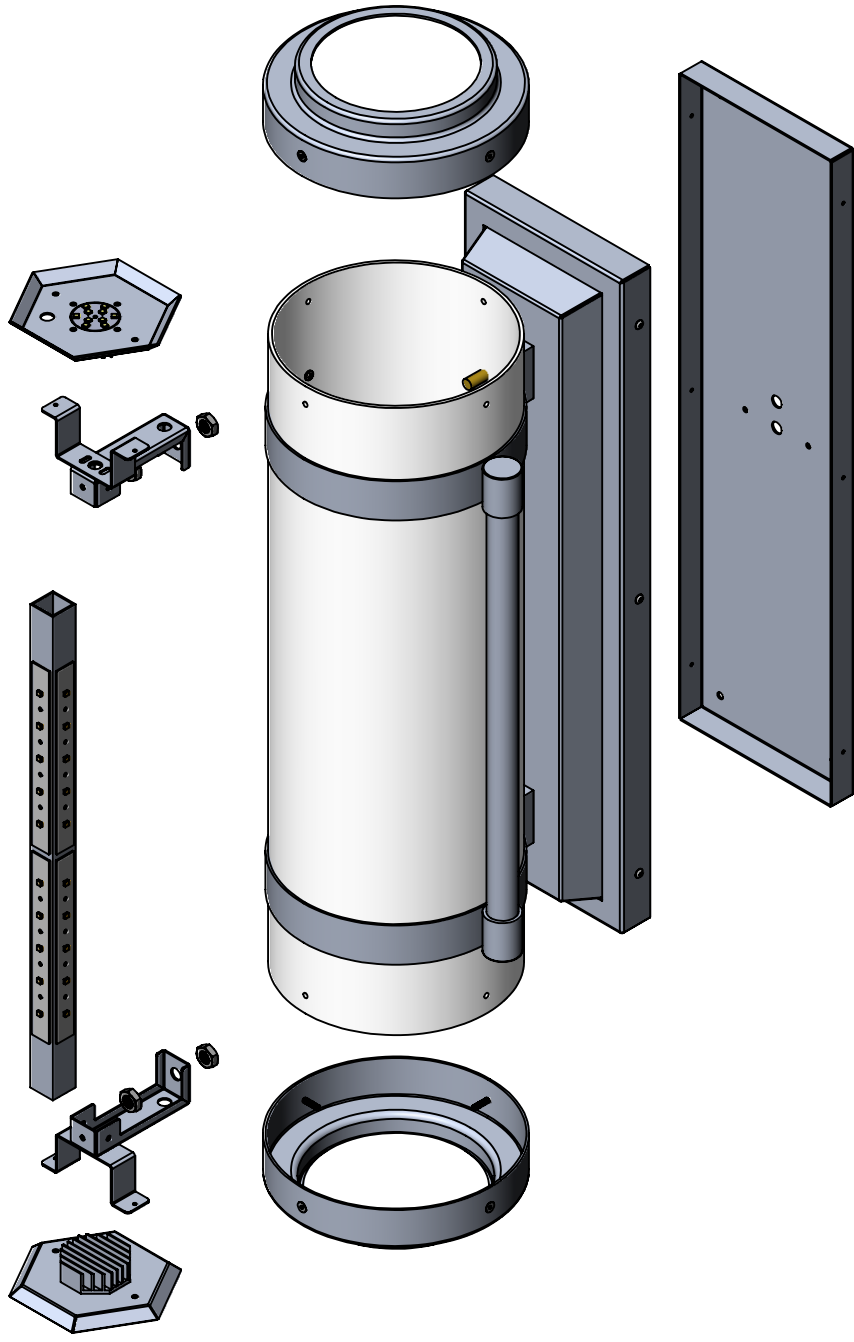

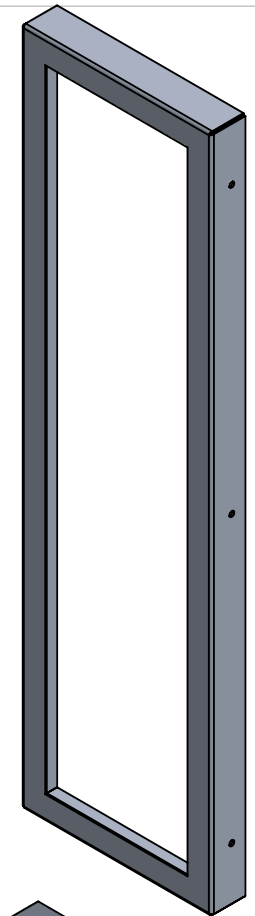
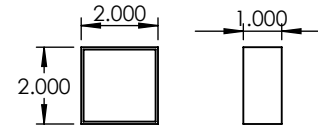
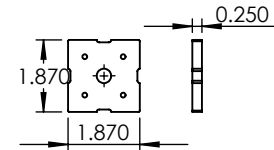
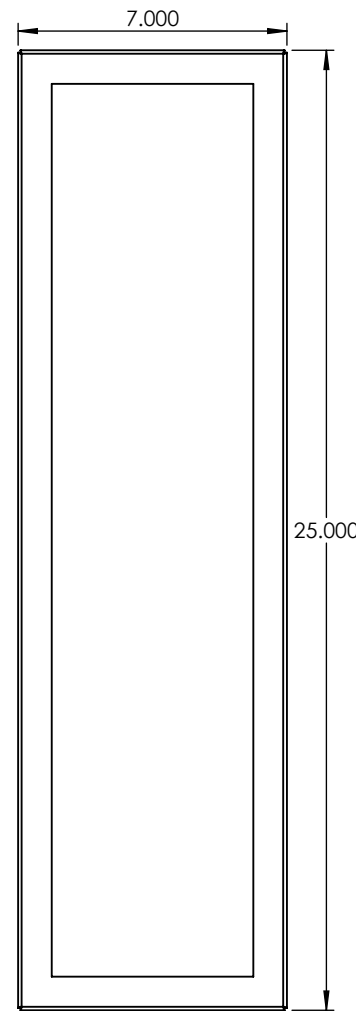
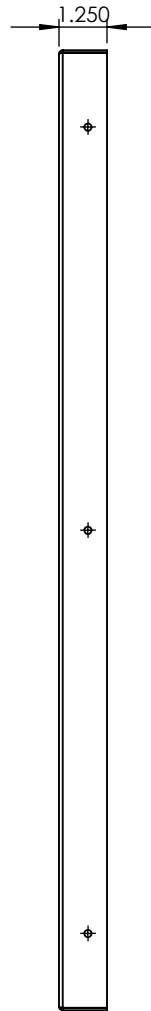
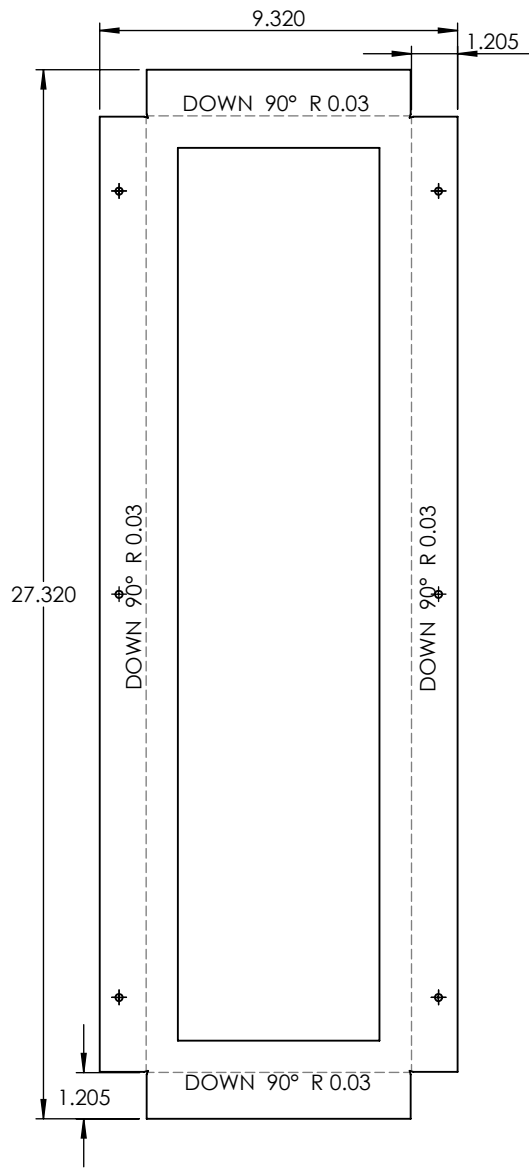

UNLESS OTHERWISE SPECIFIED:

DIMENSIONS ARE IN INCHES
 TOLERANCES:
 FRACTIONAL ±
 ANGULAR: MACH ± BEND ±
 TWO PLACE DECIMAL ±
 THREE PLACE DECIMAL ±

INTERPRET GEOMETRIC
 TOLERANCING PER:

MATERIAL

FINISH

DO NOT SCALE DRAWING

NAME

DATE

ALUMINUM 0.0635"

DRAWN

CHECKED

ENG APPR.

MFG APPR.

Q.A.

COMMENTS:

TITLE:

VSCS-ECSTR-26"-50W-AB-WF-TBL-WET-40K

PROPRIETARY AND CONFIDENTIAL

THE INFORMATION CONTAINED IN THIS
 DRAWING IS THE SOLE PROPERTY OF
 <INSERT COMPANY NAME HERE>. ANY
 REPRODUCTION IN PART OR AS A WHOLE
 WITHOUT THE WRITTEN PERMISSION OF
 <INSERT COMPANY NAME HERE> IS
 PROHIBITED.

NEXT ASSY	USED ON
APPLICATION	

SIZE	DWG. NO.	REV
A		
SCALE: 1:5	WEIGHT:	SHEET 5 OF 12

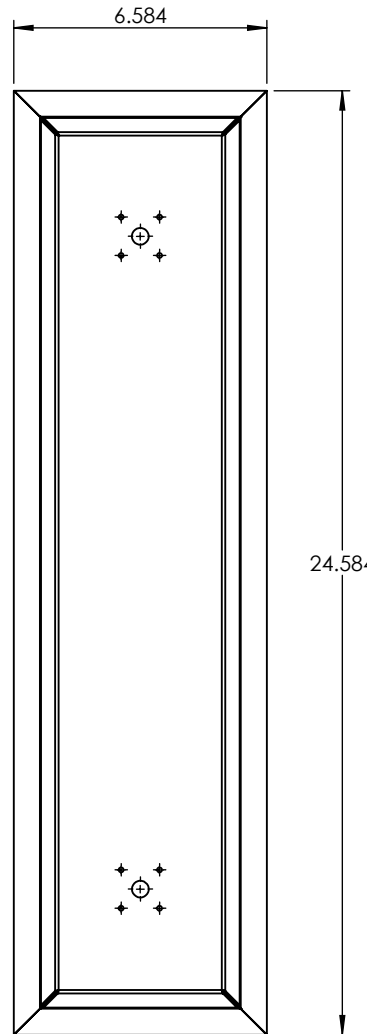
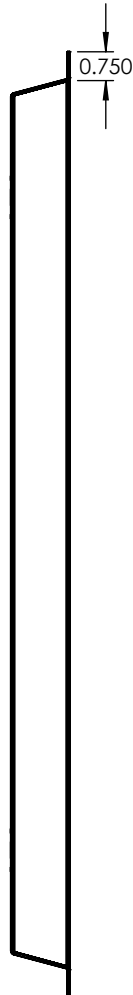
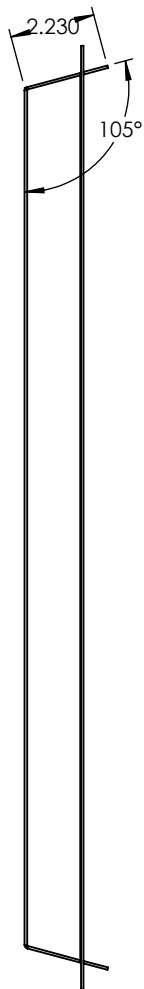
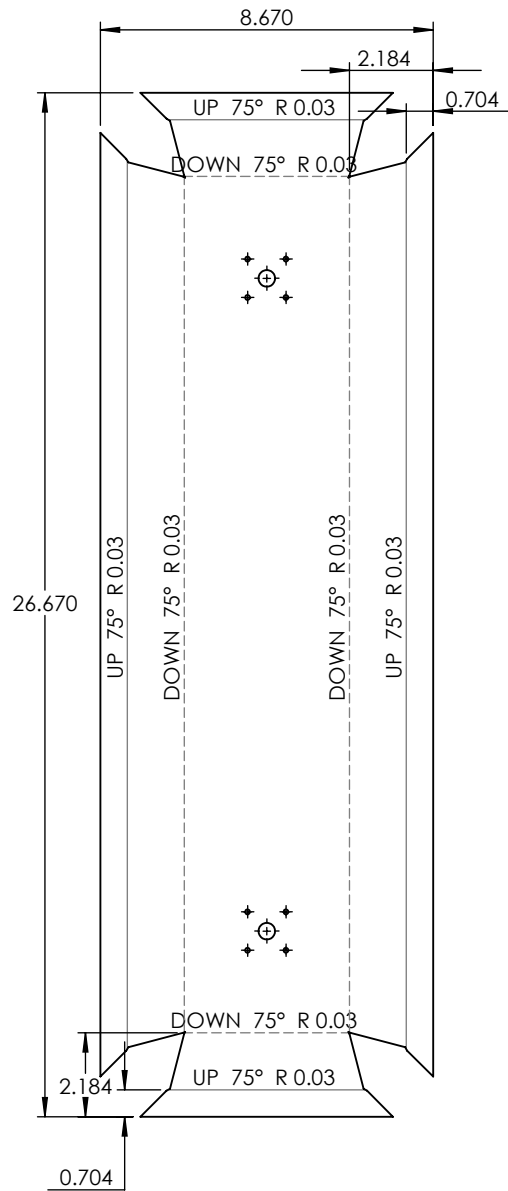

UNLESS OTHERWISE SPECIFIED:

DIMENSIONS ARE IN INCHES
 TOLERANCES:
 FRACTIONAL ±
 ANGULAR: MACH ± BEND ±
 TWO PLACE DECIMAL ±
 THREE PLACE DECIMAL ±

INTERPRET GEOMETRIC
 TOLERANCING PER:

MATERIAL

FINISH

DO NOT SCALE DRAWING

NAME

DATE

ALUMINUM 0.0635"

TITLE:

VSCS-ECSTR-26"-50W-AB-WF-TBL-WET-40K

PROPRIETARY AND CONFIDENTIAL

THE INFORMATION CONTAINED IN THIS
 DRAWING IS THE SOLE PROPERTY OF
 <INSERT COMPANY NAME HERE>. ANY
 REPRODUCTION IN PART OR AS A WHOLE
 WITHOUT THE WRITTEN PERMISSION OF
 <INSERT COMPANY NAME HERE> IS
 PROHIBITED.

NEXT ASSY

USED ON

APPLICATION

Q.A.
 COMMENTS:

SIZE DWG. NO.

REV

SCALE: 1:5 WEIGHT:

SHEET 6 OF 12

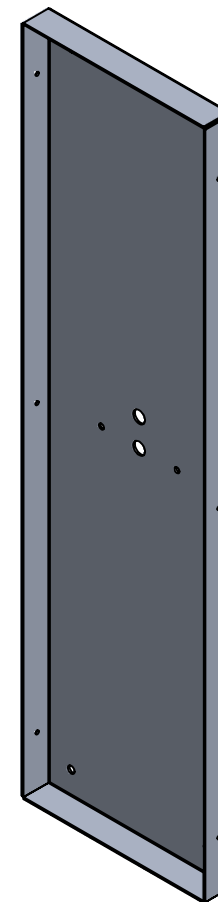
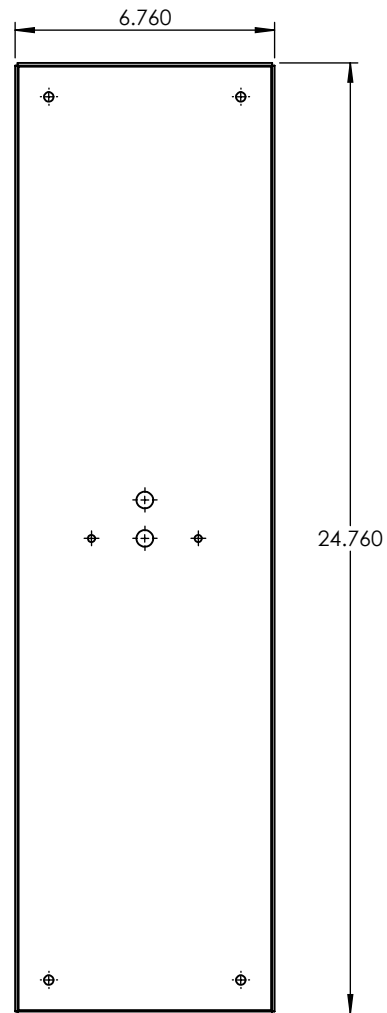
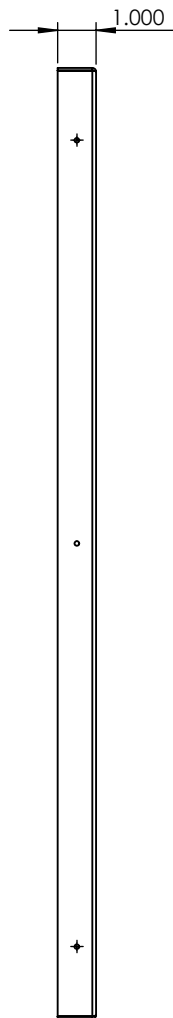
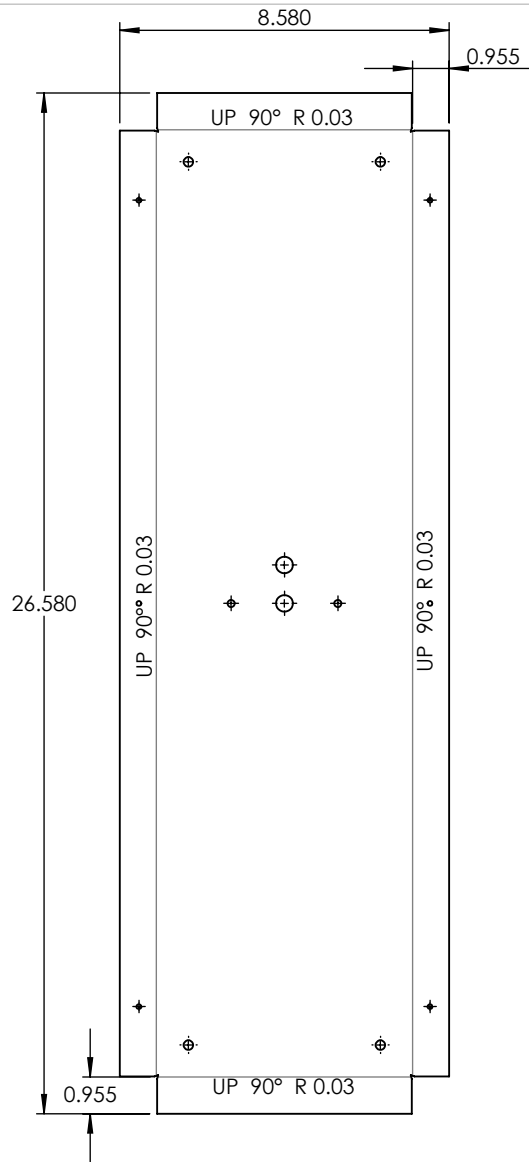

UNLESS OTHERWISE SPECIFIED:		NAME	DATE	ALUMINUM 0.0635"	
DIMENSIONS ARE IN INCHES		DRAWN			
TOLERANCES:		CHECKED			
FRACTIONAL ±		ENG APPR.			
ANGULAR: MACH ± BEND ±		MFG APPR.			
TWO PLACE DECIMAL ±		Q.A.		SIZE DWG. NO. REV	
THREE PLACE DECIMAL ±		COMMENTS:			
INTERPRET GEOMETRIC TOLERANCING PER:				SCALE: 1:5 WEIGHT: SHEET 7 OF 12	
MATERIAL					
FINISH					

PROPRIETARY AND CONFIDENTIAL
 THE INFORMATION CONTAINED IN THIS DRAWING IS THE SOLE PROPERTY OF <INSERT COMPANY NAME HERE>. ANY REPRODUCTION IN PART OR AS A WHOLE WITHOUT THE WRITTEN PERMISSION OF <INSERT COMPANY NAME HERE> IS PROHIBITED.

NEXT ASSY	USED ON
APPLICATION	

DO NOT SCALE DRAWING

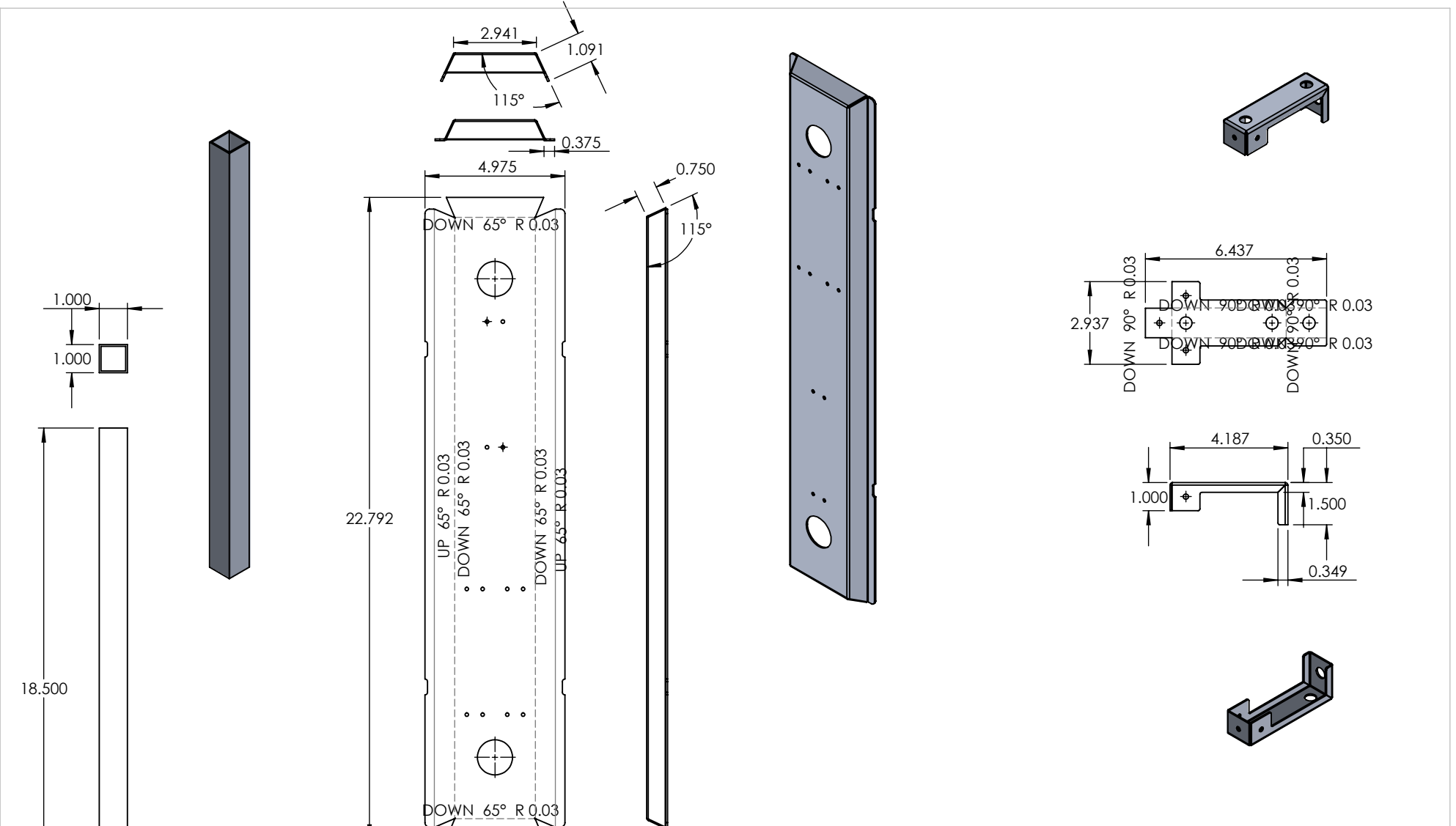

UNLESS OTHERWISE SPECIFIED:	NAME	DATE
DIMENSIONS ARE IN INCHES	DRAWN	
TOLERANCES:	CHECKED	
FRACTIONAL ±	ENG APPR.	
ANGULAR: MACH ± BEND ±	MFG APPR.	
TWO PLACE DECIMAL ±	Q.A.	
THREE PLACE DECIMAL ±	COMMENTS:	
INTERPRET GEOMETRIC TOLERANCING PER:		
MATERIAL		
FINISH		

1" SQUARE ALUMINUM TUBE		
TITLE:		
VSCS-ECSTR-26"-50W-AB-WF-TBL-WET-40K		
SIZE	DWG. NO.	REV
A		
SCALE: 1:5	WEIGHT:	SHEET 8 OF 12

PROPRIETARY AND CONFIDENTIAL
 THE INFORMATION CONTAINED IN THIS DRAWING IS THE SOLE PROPERTY OF <INSERT COMPANY NAME HERE>. ANY REPRODUCTION IN PART OR AS A WHOLE WITHOUT THE WRITTEN PERMISSION OF <INSERT COMPANY NAME HERE> IS PROHIBITED.

NEXT ASSY	USED ON
APPLICATION	DO NOT SCALE DRAWING

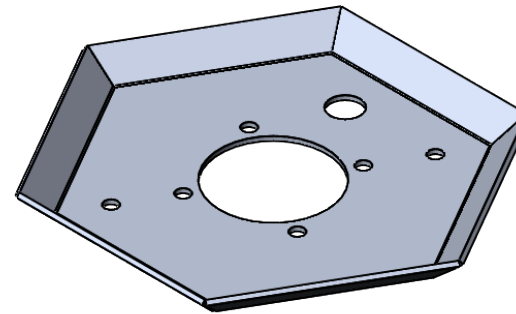
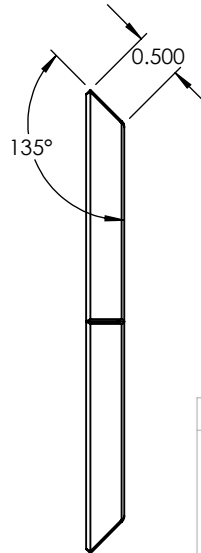
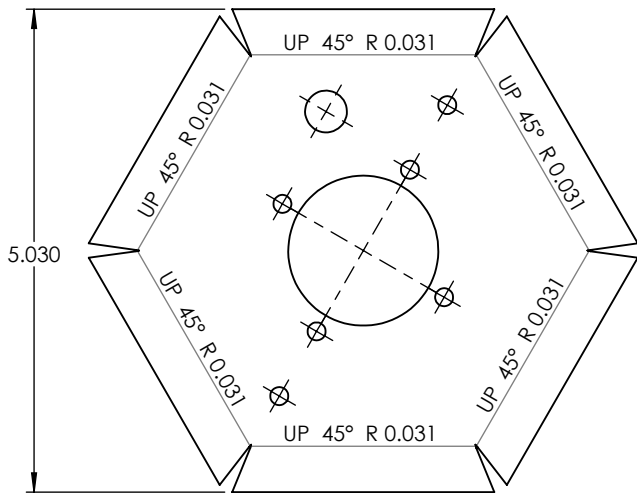
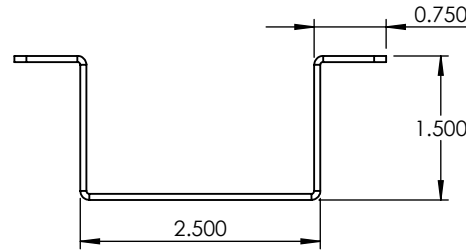
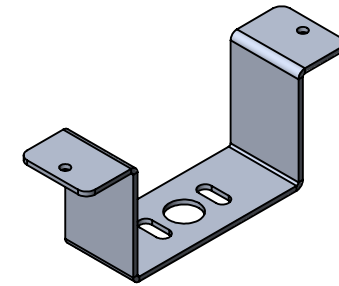
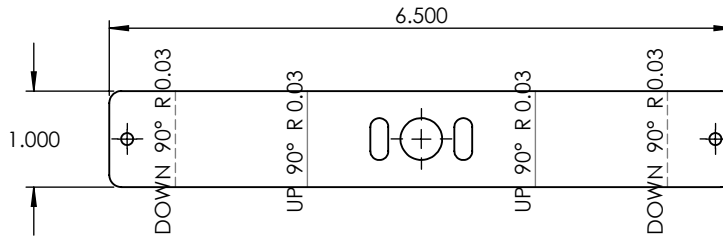

UNLESS OTHERWISE SPECIFIED:		NAME	DATE	ALUMINUM 0.0635"	
DIMENSIONS ARE IN INCHES		DRAWN		TITLE:	
TOLERANCES:		CHECKED		VSCS-ECSTR-26"-50W-AB-WF-TBL-WET-40K	
FRACTIONAL ±		ENG APPR.		SIZE	DWG. NO.
ANGULAR: MACH ± BEND ±		MFG APPR.		A	REV
TWO PLACE DECIMAL ±		Q.A.		SCALE: 1:2	WEIGHT:
THREE PLACE DECIMAL ±		COMMENTS:			SHEET 9 OF 12
INTERPRET GEOMETRIC TOLERANCING PER:	MATERIAL				
MATERIAL	FINISH				
NEXT ASSY	USED ON				
APPLICATION		DO NOT SCALE DRAWING			

PROPRIETARY AND CONFIDENTIAL
 THE INFORMATION CONTAINED IN THIS DRAWING IS THE SOLE PROPERTY OF <INSERT COMPANY NAME HERE>. ANY REPRODUCTION IN PART OR AS A WHOLE WITHOUT THE WRITTEN PERMISSION OF <INSERT COMPANY NAME HERE> IS PROHIBITED.

ITEM NO.	PART NUMBER	DESCRIPTION	QTY.
1	VSCS-ECSTR-26'''-50W-AB-WF-TBL-WET-40K-TUBE SLEEVE	SPUN ALUMINUM 0.080"	1

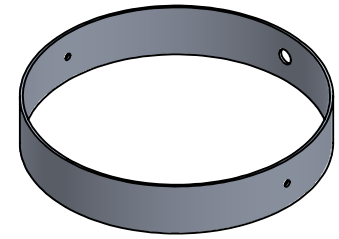
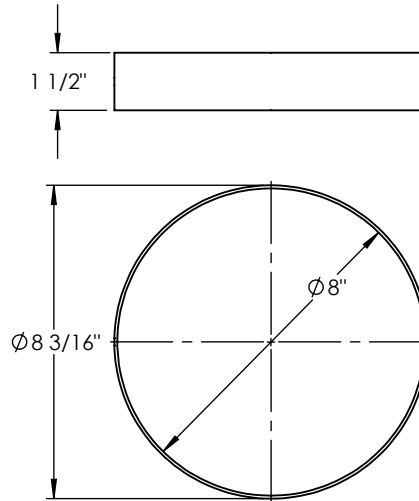
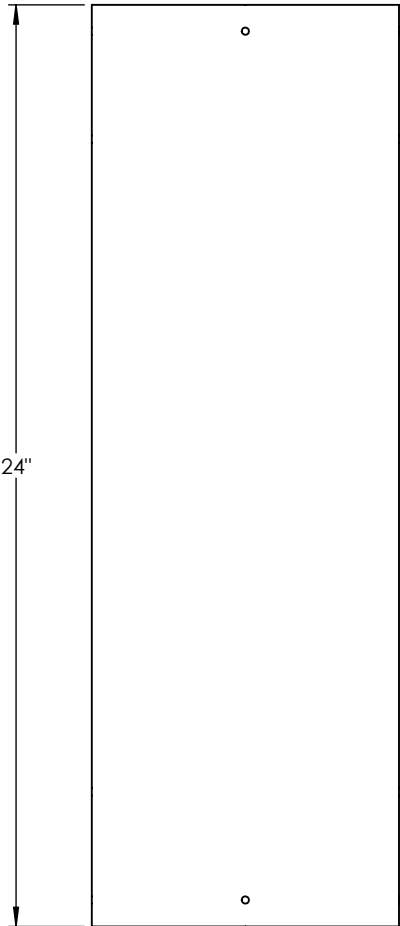
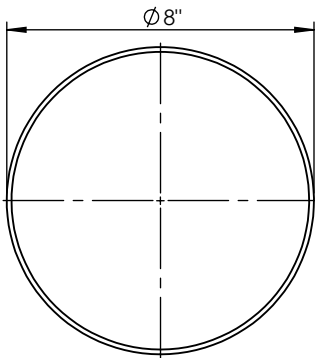

		UNLESS OTHERWISE SPECIFIED:		NAME	DATE	ACRYLIC LENS	
		DIMENSIONS ARE IN INCHES TOLERANCES: FRACTIONAL \pm ANGULAR: MACH \pm BEND \pm TWO PLACE DECIMAL \pm THREE PLACE DECIMAL \pm		DRAWN		TITLE:	
		INTERPRET GEOMETRIC TOLERANCING PER:		CHECKED		VSCS-ECSTR-26'''-50W-AB-WF-TBL-WET-40K	
		MATERIAL		ENG APPR.		SIZE	DWG. NO.
		FINISH		MFG APPR.		A	
NEXT ASSY	USED ON			Q.A.			REV
APPLICATION		DO NOT SCALE DRAWING		COMMENTS:		SCALE: 1:5	WEIGHT:
						SHEET 10 OF 12	

PROPRIETARY AND CONFIDENTIAL
THE INFORMATION CONTAINED IN THIS DRAWING IS THE SOLE PROPERTY OF <INSERT COMPANY NAME HERE>. ANY REPRODUCTION IN PART OR AS A WHOLE WITHOUT THE WRITTEN PERMISSION OF <INSERT COMPANY NAME HERE> IS PROHIBITED.

ITEM NO.	PART NUMBER	DESCRIPTION	QTY.
1	VSCS-ECSTR-26'''-50W-AB-WF-TBL-WET-40K-SPUN SHADE	SPUN ALUMINUM 0.080"	1

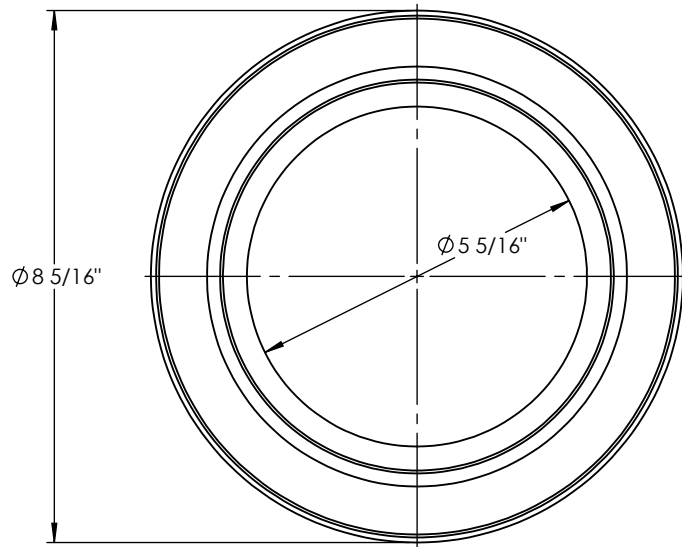
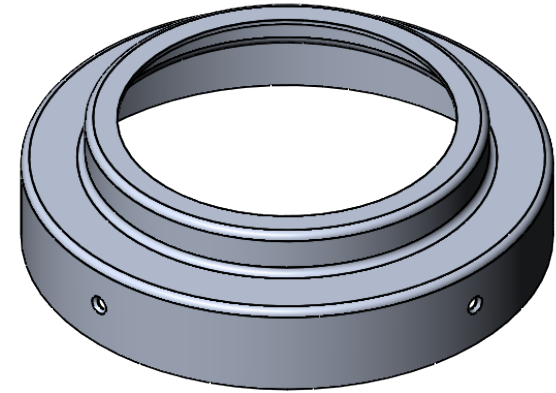
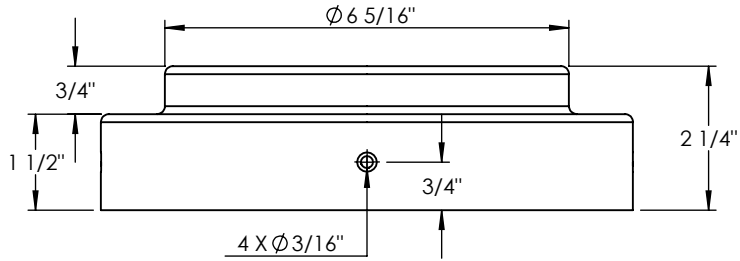

PROPRIETARY AND CONFIDENTIAL
 THE INFORMATION CONTAINED IN THIS DRAWING IS THE SOLE PROPERTY OF <INSERT COMPANY NAME HERE>. ANY REPRODUCTION IN PART OR AS A WHOLE WITHOUT THE WRITTEN PERMISSION OF <INSERT COMPANY NAME HERE> IS PROHIBITED.

		UNLESS OTHERWISE SPECIFIED:	NAME	DATE	SPUN ALUMINUM 0.080"	
		DIMENSIONS ARE IN INCHES TOLERANCES: FRACTIONAL ± ANGULAR: MACH ± BEND ± TWO PLACE DECIMAL ± THREE PLACE DECIMAL ±	DRAWN		TITLE:	
		INTERPRET GEOMETRIC TOLERANCING PER:	CHECKED		VSCS-ECSTR-26'''-50W-AB-WF-TBL-WET-40K	
		MATERIAL	ENG APPR.		SIZE DWG. NO. REV	
NEXT ASSY	USED ON	FINISH	MFG APPR.		A	
APPLICATION		DO NOT SCALE DRAWING	Q.A.		SCALE: 1:3 WEIGHT: SHEET 11 OF 12	
			COMMENTS:			

ITEM NO.	PART NUMBER	DESCRIPTION	QTY.
1	VSCS-ECSTR-26'''-50W-AB-WF-TBL-WET-40K-VERTICAL TUBE FITTER	SPUN ALUMINUM 0.080"	1

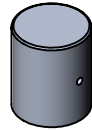
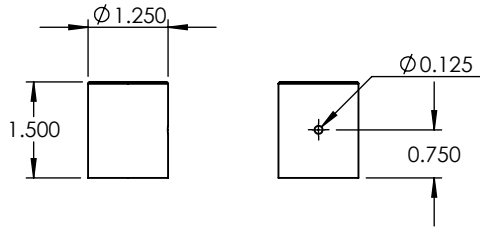

18.250

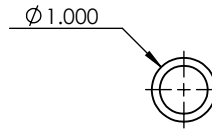

PROPRIETARY AND CONFIDENTIAL
 THE INFORMATION CONTAINED IN THIS DRAWING IS THE SOLE PROPERTY OF <INSERT COMPANY NAME HERE>. ANY REPRODUCTION IN PART OR AS A WHOLE WITHOUT THE WRITTEN PERMISSION OF <INSERT COMPANY NAME HERE> IS PROHIBITED.

		UNLESS OTHERWISE SPECIFIED:		NAME	DATE	1" ROUND ALUMINUM TUBE		
		DIMENSIONS ARE IN INCHES		DRAWN		TITLE:		
		TOLERANCES:		CHECKED		VSCS-ECSTR-26'''-50W-AB-WF-TBL-WET-40K		
		FRACTIONAL ±		ENG APPR.		SIZE	DWG. NO.	REV
		ANGULAR: MACH ± BEND ±		MFG APPR.		A		
		TWO PLACE DECIMAL ±		Q.A.		SCALE: 1:3	WEIGHT:	SHEET 12 OF 12
		THREE PLACE DECIMAL ±		COMMENTS:				
		INTERPRET GEOMETRIC TOLERANCING PER:						
		MATERIAL						
	NEXT ASSY	USED ON	FINISH					
	APPLICATION		DO NOT SCALE DRAWING					

5

4

3

2

1