

ITEM NO.	PART NUMBER	DESCRIPTION	QTY.	CUT
1	HKY-W-40W-TBK-WF-WET-DIM-SPUN ALUMINUM TOP CAP	SPUN ALUMINUM 0.080"	1	
2	HKY-W-40W-TBK-WF-WET-DIM-SPUN ALUMINUM CAP	SPUN ALUMINUM 0.080"	1	
3	HKY-W-40W-TBK-WF-WET-DIM-BACKPLATE	ALUMINUM 0.0635"	1	
4	HKY-W-40W-TBK-WF-WET-DIM-FIREPLATE	ALUMINUM 0.0635"	1	
5	HKY-W-40W-TBK-WF-WET-DIM-DRIVER BRACKET	ALUMINUM 0.0635"	1	
6	HKY-W-40W-TBK-WF-WET-DIM-VERTICAL TUBE GUIDE	ALUMINUM 0.085"	1	
7	HKY-W-40W-TBK-WF-WET-DIM-ROUND VERTICAL BARS	ALUMINUM 0.0635"	4	
8	HKY-W-40W-TBK-WF-WET-DIM-SQUARE TUBE BRACKET	ALUMINUM 0.0635"	1	
9	HKY-W-40W-TBK-WF-WET-DIM-TUBE BRACKET PLATE	ALUMINUM 0.250" PLATE	1	
10	HKY-W-40W-TBK-WF-WET-DIM-TUBE BRACKET PLATE BLANK	ALUMINUM 0.250" PLATE	1	
11	HKY-W-40W-TBK-WF-WET-DIM-CIRCULAR BAR	ALUMINUM 0.500" PLATE	1	
12	HKY-W-40W-TBK-WF-WET-DIM-BACKPLATE TAB	25 GAUGE ALUMINUM	4	
13	HKY-W-40W-TBK-WF-WET-DIM-ACRYLIC TUBE	ACRYLIC LENS	1	
14	HKY-W-40W-TBK-WF-WET-DIM-SQUARE LED TUBE	1" SQUARE ALUMINUM TUBE	1	
15	HKY-W-40W-TBK-WF-WET-DIM-SQUARE ARM TUBE	1" SQUARE ALUMINUM TUBE	1	
16	KTLD-25-UV-700-VDIM-LA1	DRIVER	2	
17	Alttailed_PN110B_RevC	LED	4	

UNLESS OTHERWISE SPECIFIED:

DIMENSIONS ARE IN INCHES  
 TOLERANCES:  
 FRACTIONAL ± .003  
 ANGULAR: MACH ± .01 BEND ±  
 TWO PLACE DECIMAL ±  
 THREE PLACE DECIMAL ±.001

INTERPRET GEOMETRIC  
 TOLERANCING PER:

MATERIAL

FINISH

NAME DATE

DRAWN

CHECKED

ENG APPR.

MFG APPR.

Q.A.

COMMENTS:

TITLE:

HKY-W-40W-TBK-WF-WET-DIM

SIZE DWG. NO. REV

**A** TICKET 26025

SCALE: 1:8 WEIGHT: SHEET 1 OF 9



ALL BEND RADIUS .030"

APPLICATION

DO NOT SCALE DRAWING

5

4

3

2

1

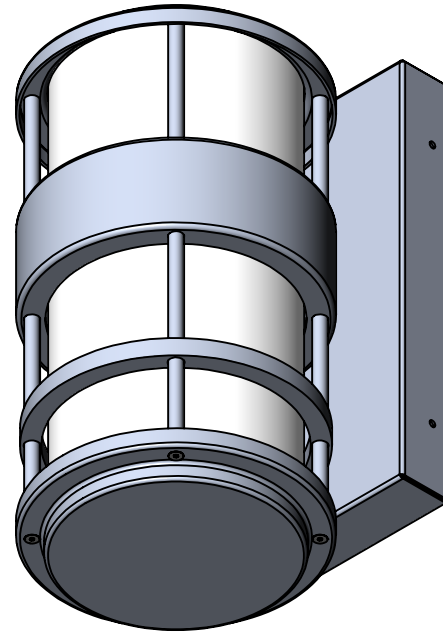
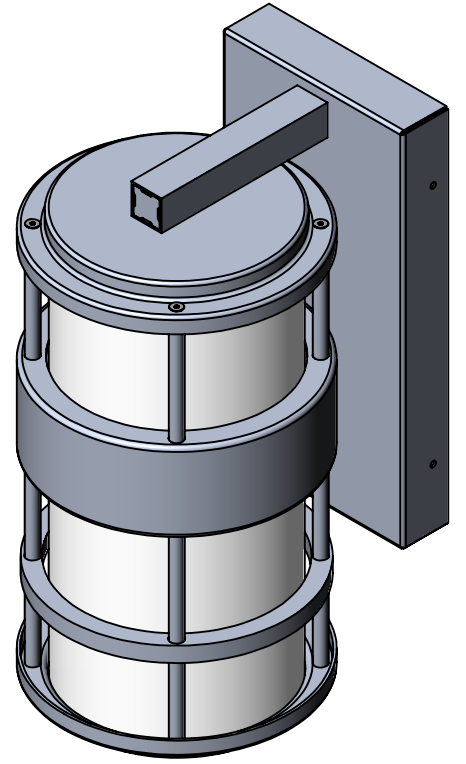
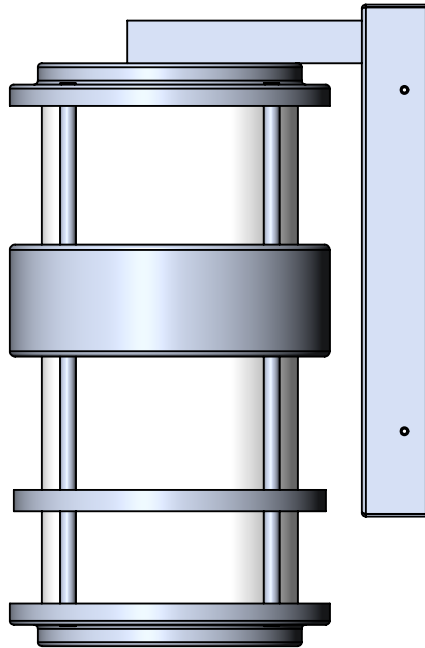
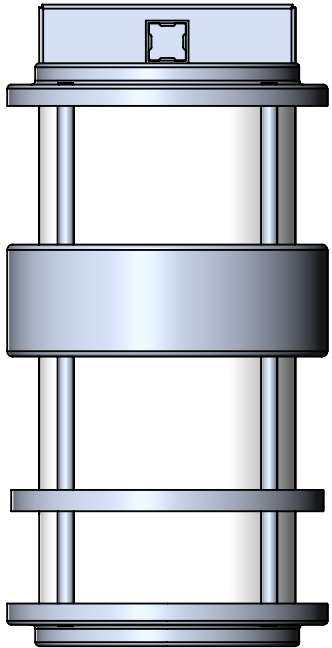
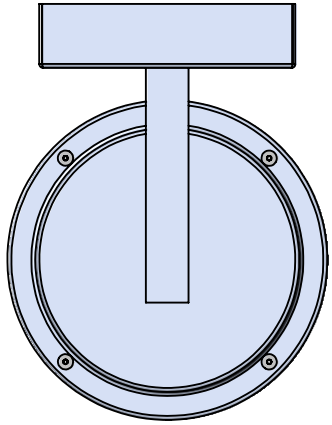

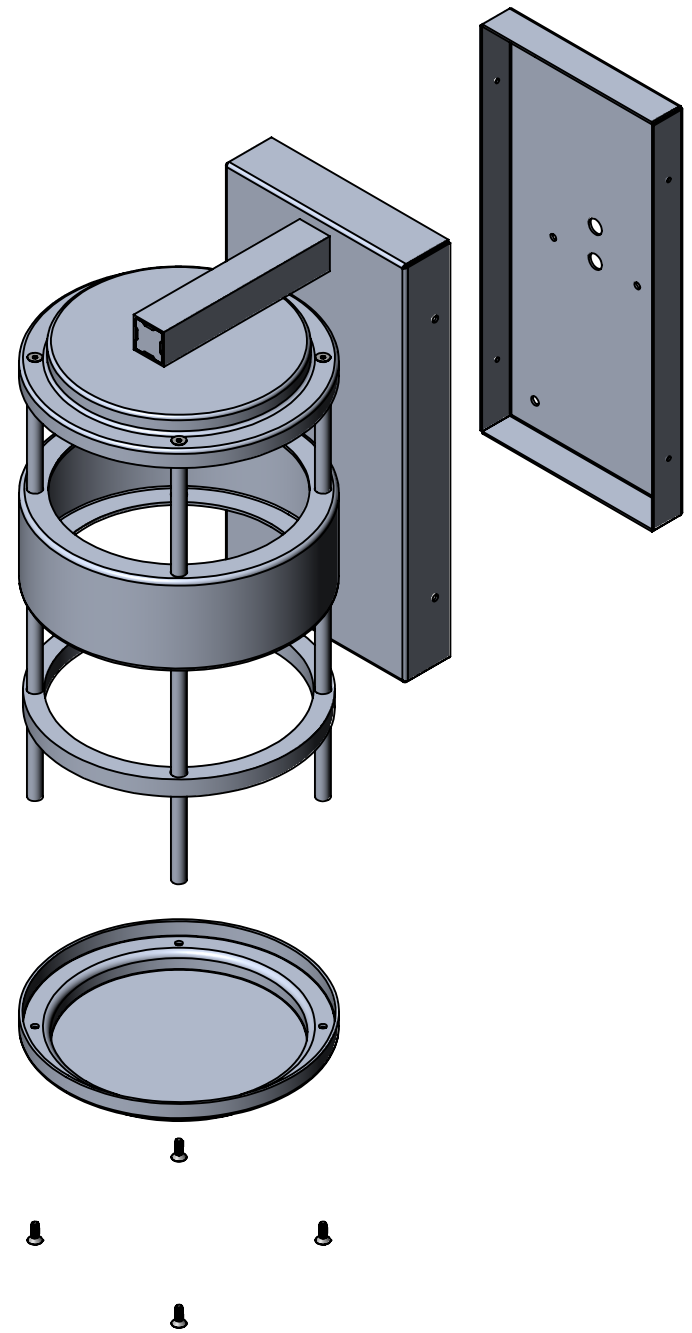
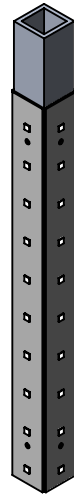
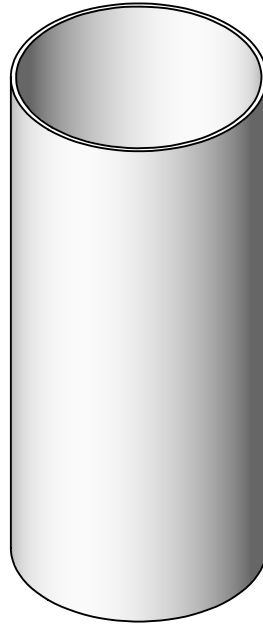
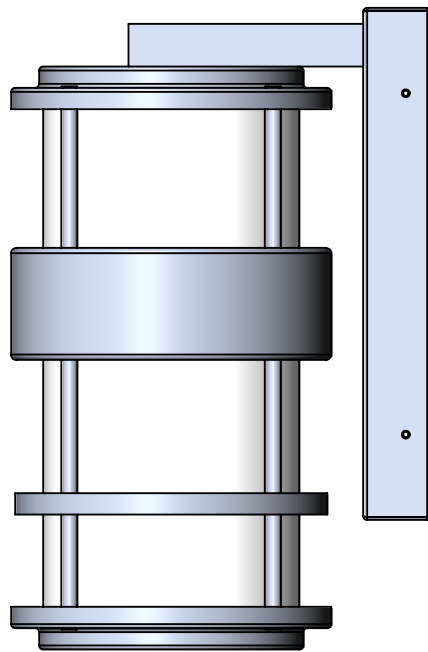
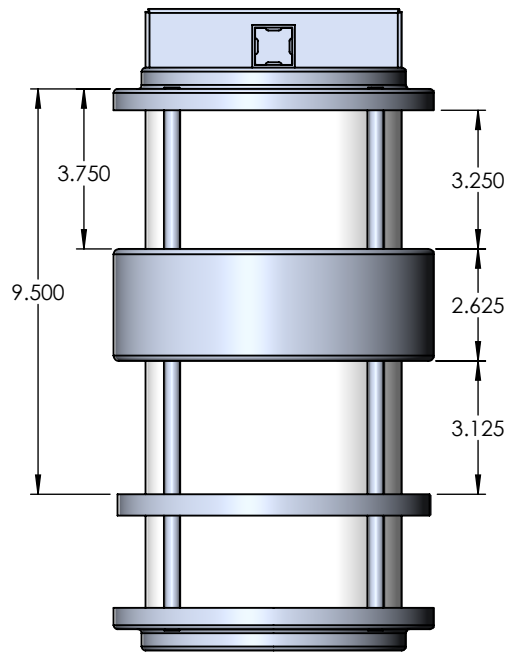

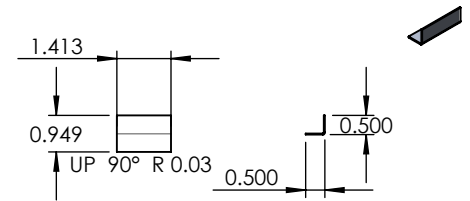
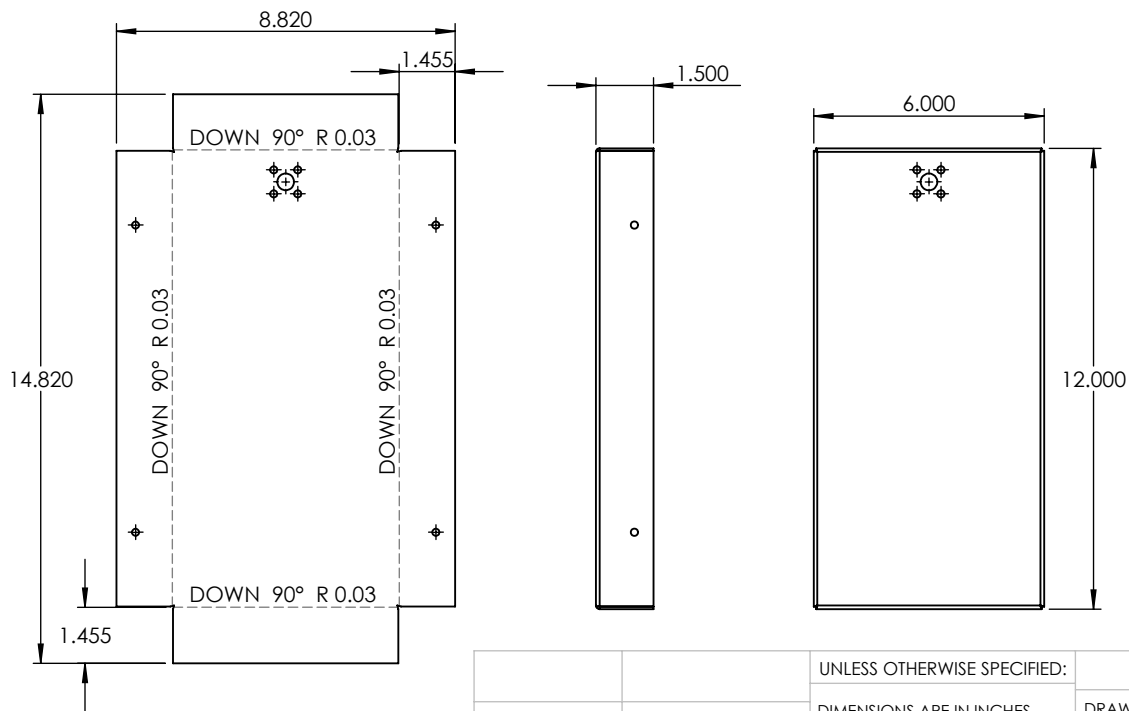

**PROPRIETARY AND CONFIDENTIAL**  
 THE INFORMATION CONTAINED IN THIS DRAWING IS THE SOLE PROPERTY OF <INSERT COMPANY NAME HERE>. ANY REPRODUCTION IN PART OR AS A WHOLE WITHOUT THE WRITTEN PERMISSION OF <INSERT COMPANY NAME HERE> IS PROHIBITED.

		UNLESS OTHERWISE SPECIFIED:	NAME	DATE	ALUMINUM 0.0635"	
		DIMENSIONS ARE IN INCHES TOLERANCES: FRACTIONAL ± ANGULAR: MACH ± BEND ± TWO PLACE DECIMAL ± THREE PLACE DECIMAL ±	DRAWN			
		INTERPRET GEOMETRIC TOLERANCING PER:	CHECKED		HKY-W-40W-TBK-WF-WET-DIM	
		MATERIAL	ENG APPR.			
		FINISH	MFG APPR.		SIZE DWG. NO. REV	
NEXT ASSY	USED ON		Q.A.			
APPLICATION		DO NOT SCALE DRAWING	COMMENTS:		SCALE: 1:5 WEIGHT: SHEET 4 OF 9	

5

4

3

2

1

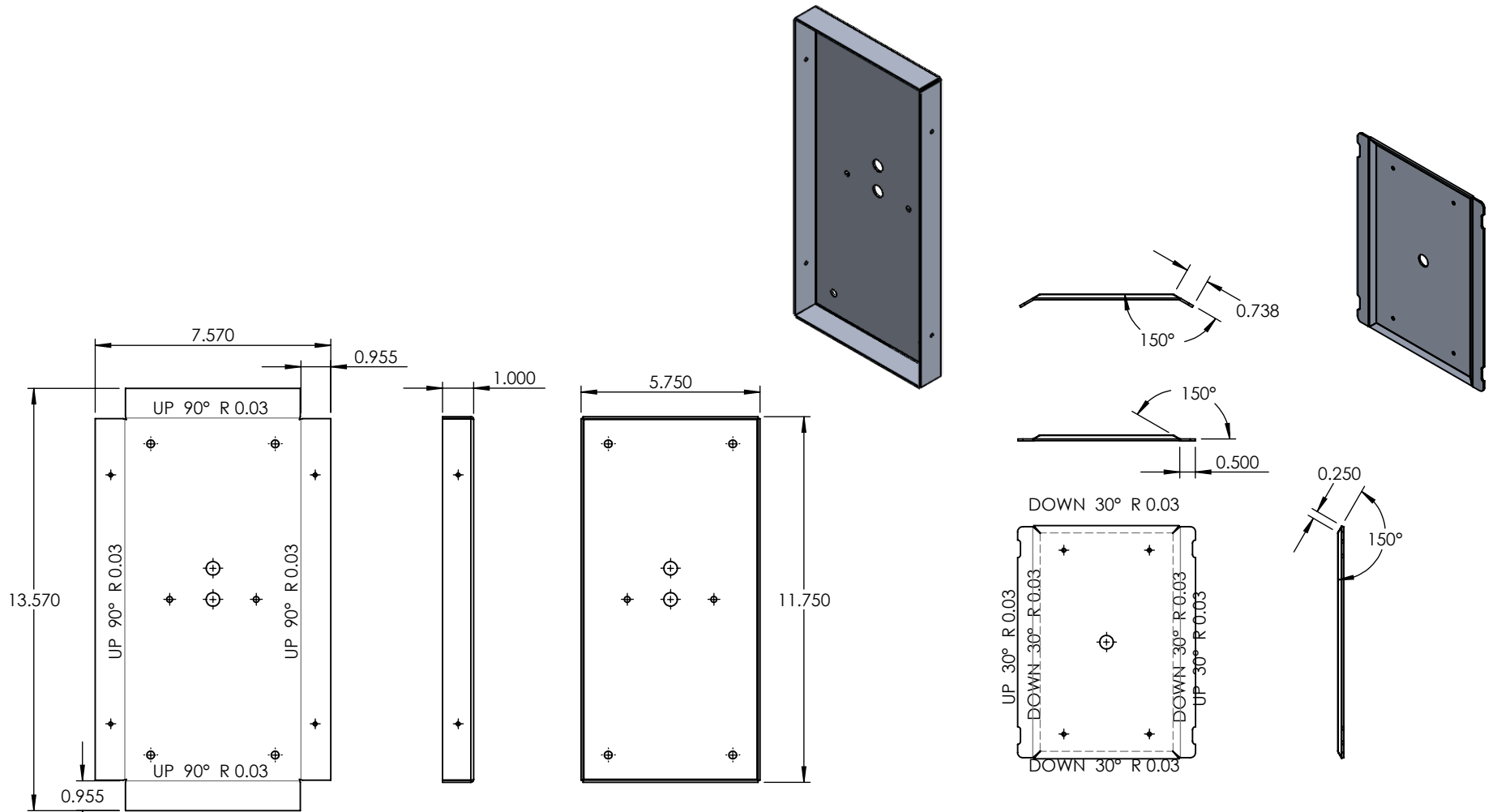

**PROPRIETARY AND CONFIDENTIAL**  
 THE INFORMATION CONTAINED IN THIS DRAWING IS THE SOLE PROPERTY OF <INSERT COMPANY NAME HERE>. ANY REPRODUCTION IN PART OR AS A WHOLE WITHOUT THE WRITTEN PERMISSION OF <INSERT COMPANY NAME HERE> IS PROHIBITED.

		UNLESS OTHERWISE SPECIFIED:	NAME	DATE
		DIMENSIONS ARE IN INCHES	DRAWN	
		TOLERANCES:	CHECKED	
		FRACTIONAL ±	ENG APPR.	
		ANGULAR: MACH ± BEND ±	MFG APPR.	
		TWO PLACE DECIMAL ±	Q.A.	
		THREE PLACE DECIMAL ±	COMMENTS:	
		INTERPRET GEOMETRIC TOLERANCING PER:		
		MATERIAL		
NEXT ASSY	USED ON	FINISH		
APPLICATION		DO NOT SCALE DRAWING		

ALUMINUM 0.0635"		
TITLE:		
HKY-W-40W-TBK-WF-WET-DIM		
SIZE	DWG. NO.	REV
<b>A</b>		
SCALE: 1:5	WEIGHT:	SHEET 5 OF 9

5

4

3

2

1

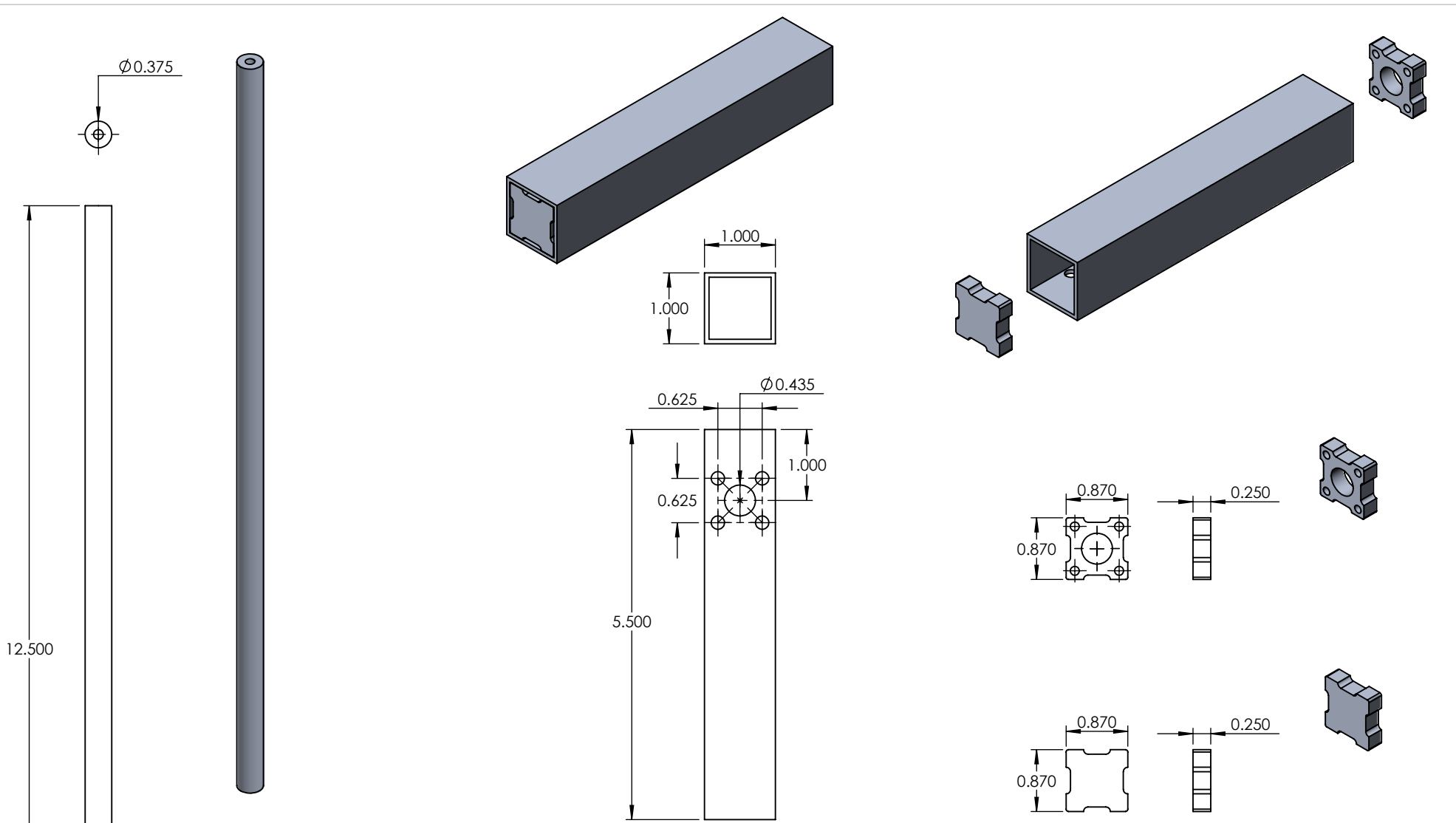

**PROPRIETARY AND CONFIDENTIAL**  
 THE INFORMATION CONTAINED IN THIS DRAWING IS THE SOLE PROPERTY OF <INSERT COMPANY NAME HERE>. ANY REPRODUCTION IN PART OR AS A WHOLE WITHOUT THE WRITTEN PERMISSION OF <INSERT COMPANY NAME HERE> IS PROHIBITED.

		UNLESS OTHERWISE SPECIFIED:		NAME	DATE
		DIMENSIONS ARE IN INCHES	DRAWN		
		TOLERANCES:	CHECKED		
		FRACTIONAL ±	ENG APPR.		
		ANGULAR: MACH ± BEND ±	MFG APPR.		
		TWO PLACE DECIMAL ±	Q.A.		
		THREE PLACE DECIMAL ±	COMMENTS:		
		INTERPRET GEOMETRIC TOLERANCING PER:			
		MATERIAL			
		FINISH			
NEXT ASSY	USED ON				
APPLICATION	DO NOT SCALE DRAWING				

1" SQUARE ALUMINUM TUBE		
TITLE:		
HKY-W-40W-TBK-WF-WET-DIM		
SIZE	DWG. NO.	REV
<b>A</b>		
SCALE: 1:2	WEIGHT:	SHEET 6 OF 9

5

4

3

2

1

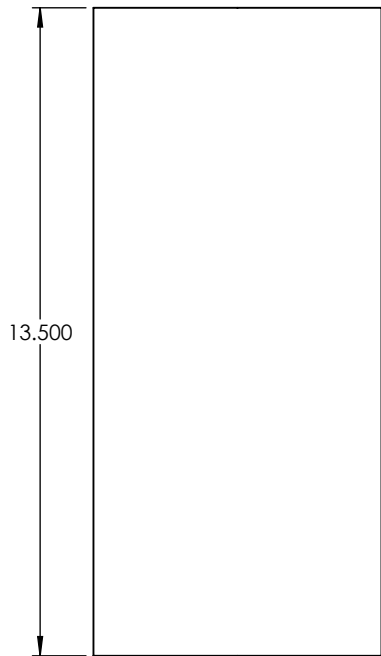
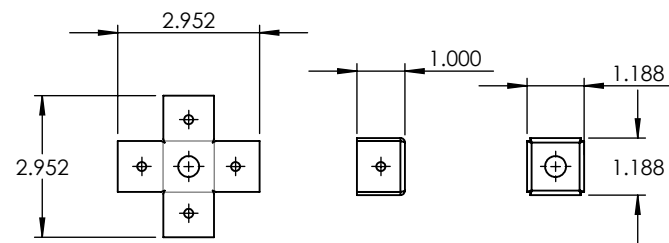
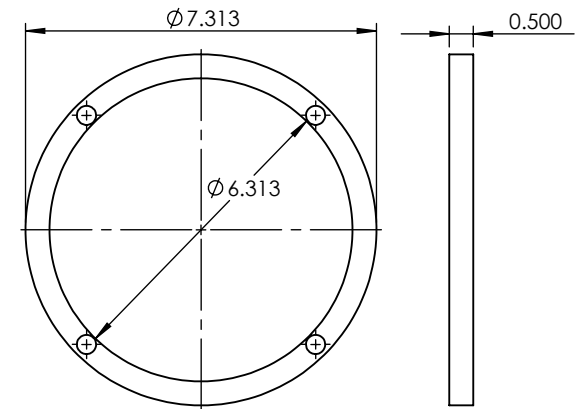
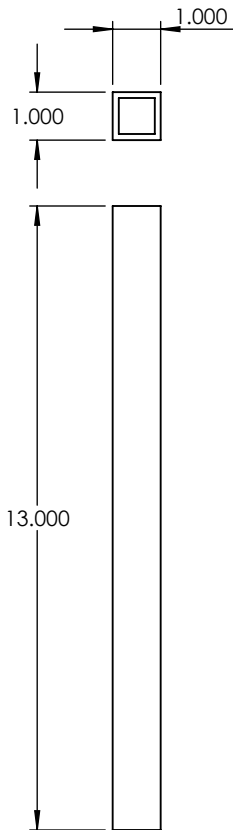
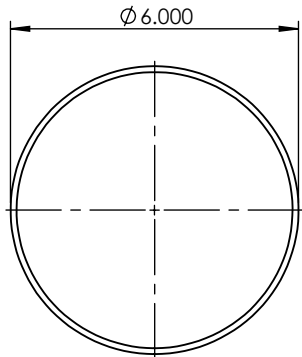

**PROPRIETARY AND CONFIDENTIAL**  
 THE INFORMATION CONTAINED IN THIS DRAWING IS THE SOLE PROPERTY OF <INSERT COMPANY NAME HERE>. ANY REPRODUCTION IN PART OR AS A WHOLE WITHOUT THE WRITTEN PERMISSION OF <INSERT COMPANY NAME HERE> IS PROHIBITED.

		UNLESS OTHERWISE SPECIFIED:		NAME	DATE
		DIMENSIONS ARE IN INCHES		DRAWN	
		TOLERANCES:		CHECKED	
		FRACTIONAL ±		ENG APPR.	
		ANGULAR: MACH ± BEND ±		MFG APPR.	
		TWO PLACE DECIMAL ±		Q.A.	
		THREE PLACE DECIMAL ±		COMMENTS:	
		INTERPRET GEOMETRIC TOLERANCING PER:			
		MATERIAL			
NEXT ASSY	USED ON	FINISH			
APPLICATION		DO NOT SCALE DRAWING			

ALUMINUM 0.500" PLATE

TITLE:

HKY-W-40W-TBK-WF-WET-DIM

SIZE	DWG. NO.	REV
<b>A</b>		

SCALE: 1:4	WEIGHT:	SHEET 7 OF 9
------------	---------	--------------

5

4

3

2

1

ITEM NO.	PART NUMBER	DESCRIPTION	QTY.
1	HKY-W-40W-TBK-WF-WET-DIM-SPUN ALUMINUM CAP	SPUN ALUMINUM 0.080"	1

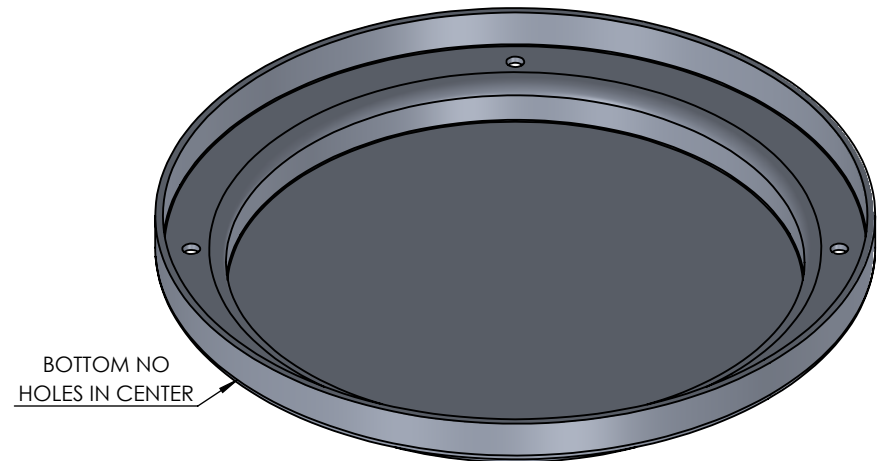
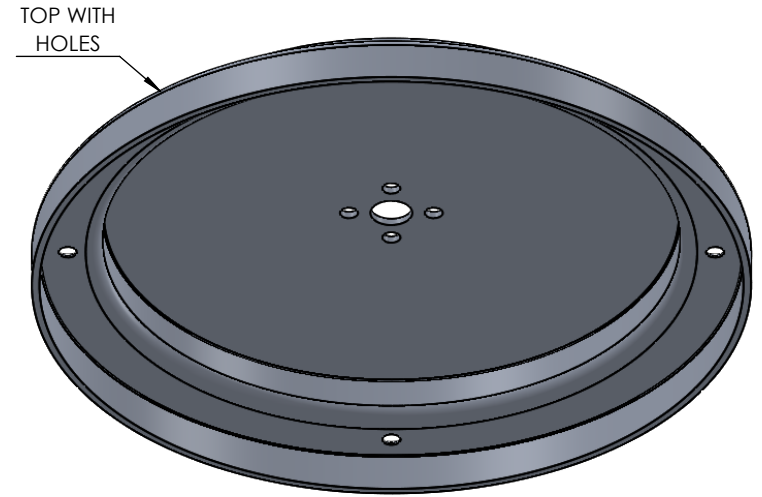
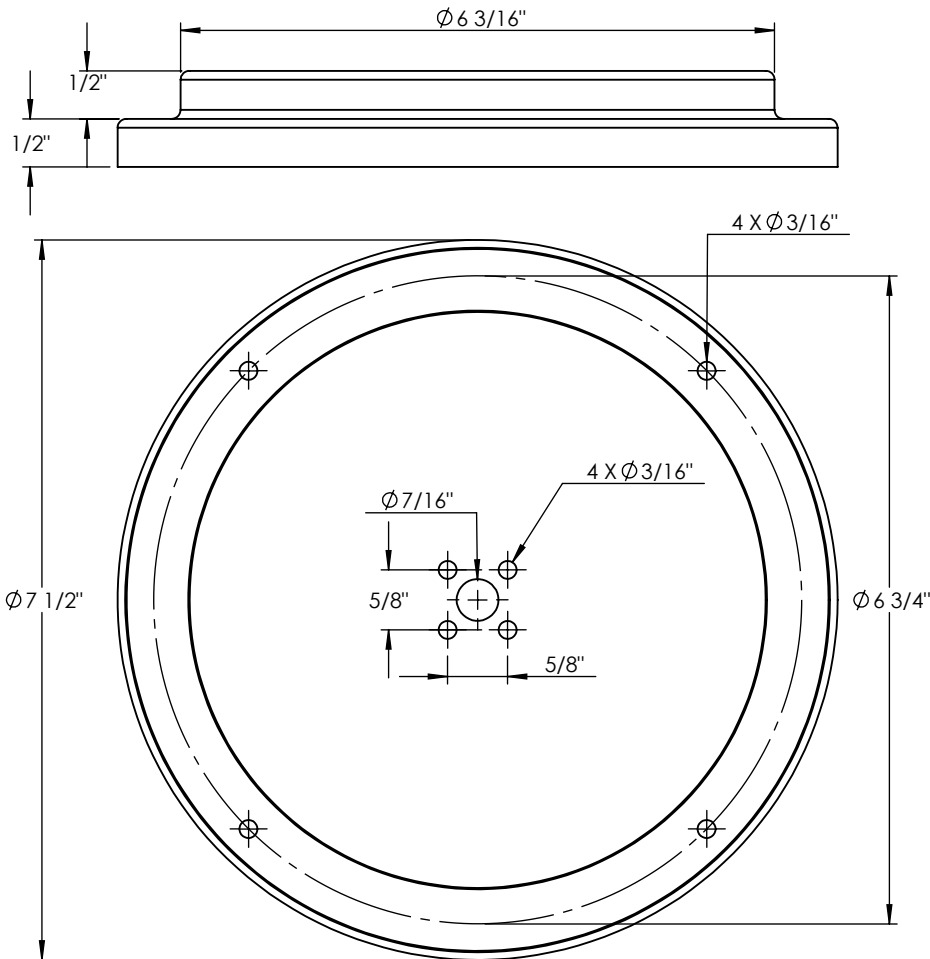

**PROPRIETARY AND CONFIDENTIAL**  
 THE INFORMATION CONTAINED IN THIS DRAWING IS THE SOLE PROPERTY OF <INSERT COMPANY NAME HERE>. ANY REPRODUCTION IN PART OR AS A WHOLE WITHOUT THE WRITTEN PERMISSION OF <INSERT COMPANY NAME HERE> IS PROHIBITED.

UNLESS OTHERWISE SPECIFIED:		NAME	DATE
DIMENSIONS ARE IN INCHES		DRAWN	
TOLERANCES:		CHECKED	
FRACTIONAL $\pm$		ENG APPR.	
ANGULAR: MACH $\pm$ BEND $\pm$		MFG APPR.	
TWO PLACE DECIMAL $\pm$		Q.A.	
THREE PLACE DECIMAL $\pm$		COMMENTS:	
INTERPRET GEOMETRIC TOLERANCING PER:			
MATERIAL			
FINISH			
NEXT ASSY	USED ON		
APPLICATION			
DO NOT SCALE DRAWING			

SPUN ALUMINUM 0.080"		
TITLE:		
HKY-W-40W-TBK-WF-WET-DIM		
SIZE	DWG. NO.	REV
<b>A</b>		
SCALE: 1:2	WEIGHT:	SHEET 8 OF 9

5

4

3

2

1



ITEM NO.	PART NUMBER	DESCRIPTION	QTY.
1	HKY-W-40W-TBK-WF-WET-DIM-VERTICAL TUBE GUIDE	ALUMINUM 0.085"	1

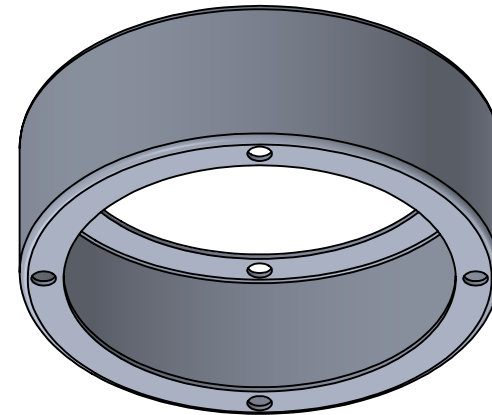
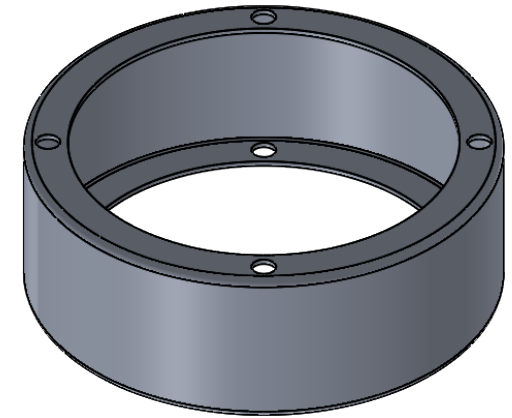
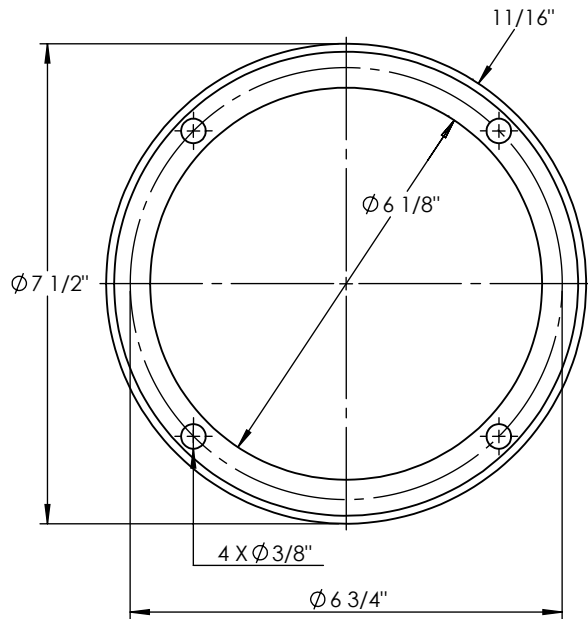
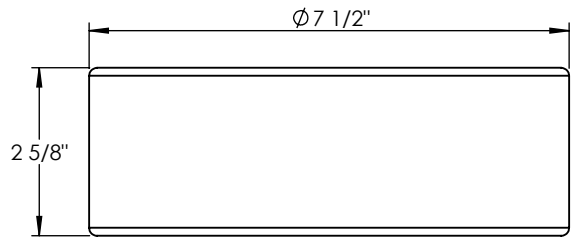

**PROPRIETARY AND CONFIDENTIAL**  
 THE INFORMATION CONTAINED IN THIS DRAWING IS THE SOLE PROPERTY OF <INSERT COMPANY NAME HERE>. ANY REPRODUCTION IN PART OR AS A WHOLE WITHOUT THE WRITTEN PERMISSION OF <INSERT COMPANY NAME HERE> IS PROHIBITED.

		UNLESS OTHERWISE SPECIFIED:	NAME	DATE	ALUMINUM 0.085"	
		DIMENSIONS ARE IN INCHES TOLERANCES: FRACTIONAL ± ANGULAR: MACH ± BEND ± TWO PLACE DECIMAL ± THREE PLACE DECIMAL ±	DRAWN		TITLE:	
		INTERPRET GEOMETRIC TOLERANCING PER:	CHECKED		HKY-W-40W-TBK-WF-WET-DIM	
		MATERIAL	ENG APPR.		SIZE	DWG. NO.
		FINISH	MFG APPR.		<b>A</b>	REV
NEXT ASSY	USED ON		Q.A.		SCALE: 1:3	WEIGHT:
APPLICATION		DO NOT SCALE DRAWING	COMMENTS:		SHEET 9 OF 9	