

ITEM NO.	PART NUMBER	DESCRIPTION	QTY.	CUT
1	HFU-W-SLT-24W-MN-WF-TBL-24"-DIM-35K-FIREPLATE	22 GAUGE	1	
2	HFU-W-SLT-24W-MN-WF-TBL-24"-DIM-35K-BACKPLATE	22 GAUGE	1	
3	HFU-W-SLT-24W-MN-WF-TBL-24"-DIM-35K-SQUARE ACCENT	18 GAUGE	1	
4	HFU-W-SLT-24W-MN-WF-TBL-24"-DIM-35K-SQUARE ACCENT 2	18 GAUGE	2	
5	HFU-W-SLT-24W-MN-WF-TBL-24"-DIM-35K-SQUARE ACCENT BRACKET	18 GAUGE	2	
6	HFU-W-SLT-24W-MN-WF-TBL-24"-DIM-35K-SPUN END CAPS	SPUN 18 GAUGE	2	
7	HFU-W-SLT-24W-MN-WF-TBL-24"-DIM-35K-ACRYLIC	ACRYLIC	1	
8	AC29CD700AT2Q LED DRIVER	DRIVER	1	
9	AltLED_PN110B_RevC	LED	2	

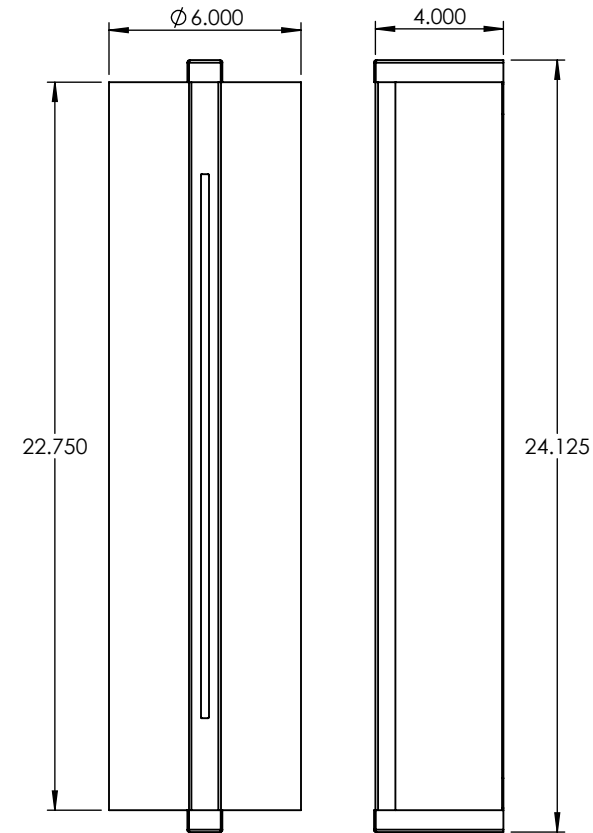
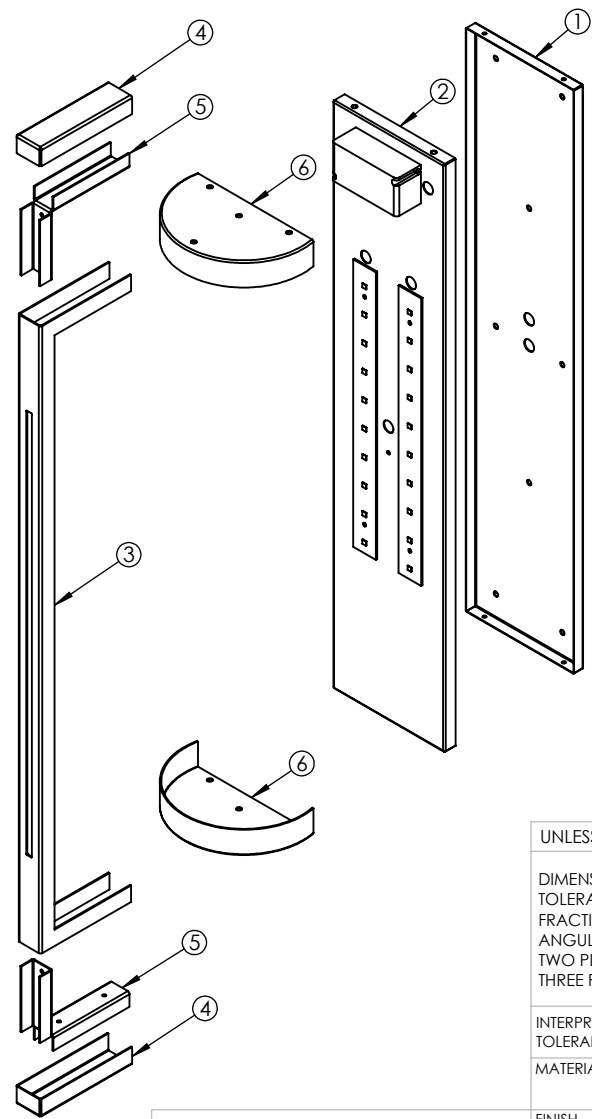
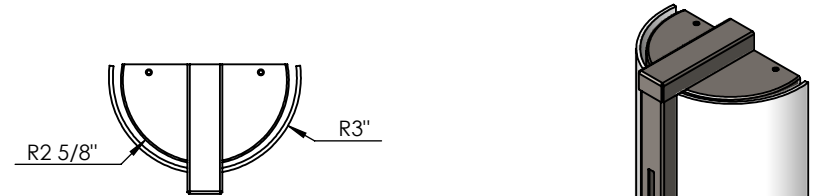

ALL BEND RADIUS .030"

UNLESS OTHERWISE SPECIFIED:	NAME	DATE
DIMENSIONS ARE IN INCHES	DRAWN	
TOLERANCES:	CHECKED	
FRACTIONAL ± .003	ENG APPR.	
ANGULAR: MACH ± .01 BEND ±	MFG APPR.	
TWO PLACE DECIMAL ±	Q.A.	
THREE PLACE DECIMAL ±.001	COMMENTS:	
INTERPRET GEOMETRIC TOLERANCING PER:		
MATERIAL		
FINISH		

TITLE:
HFU-W-SLT-24W-MN-WF-24"-DIM-35K

SIZE	DWG. NO.	REV
A	TICKET 26027	
SCALE: 1:6	WEIGHT:	SHEET 1 OF 7

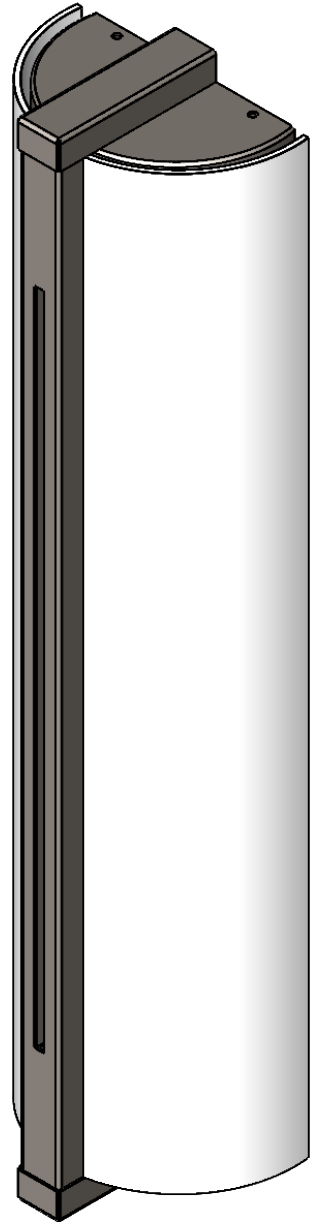
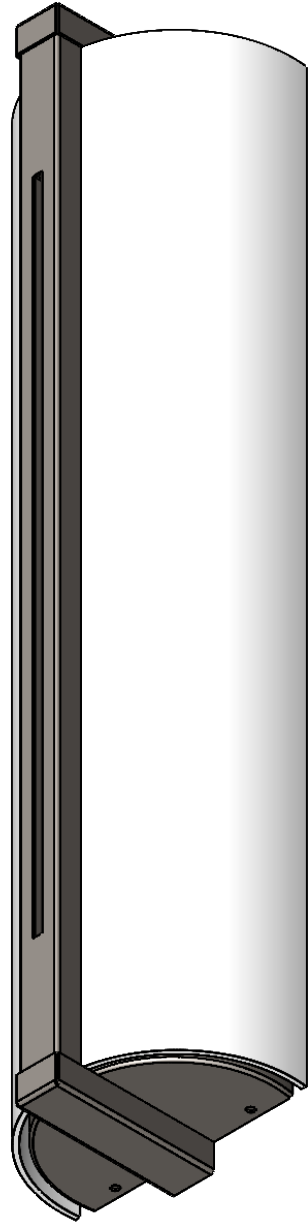
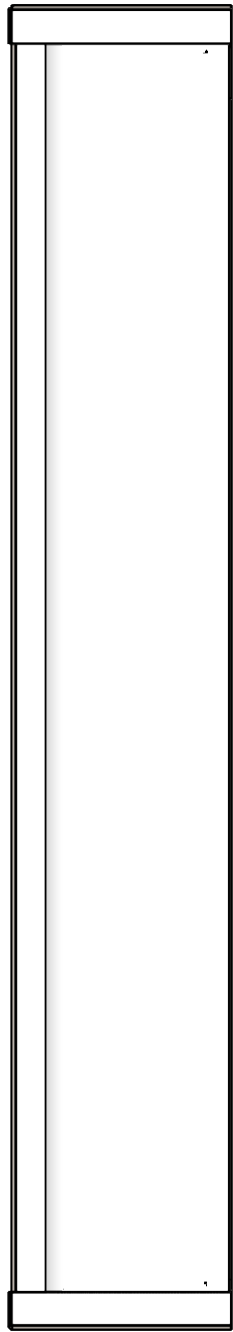
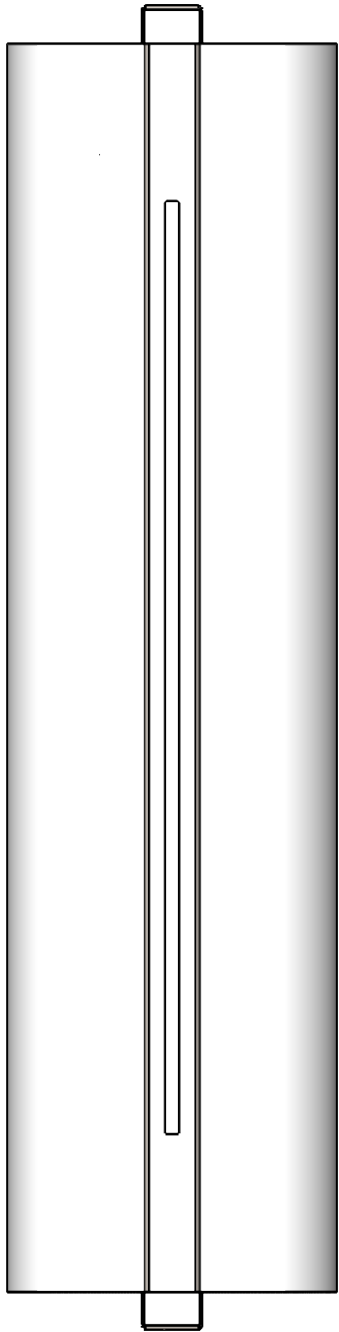

THE SPINNING AND ACRYLIC LENS ARE BOLTED TO THE ACCENT BRACKET FROM THE INSIDE TO FORM ONE FINAL ASSEMBLED PIECE

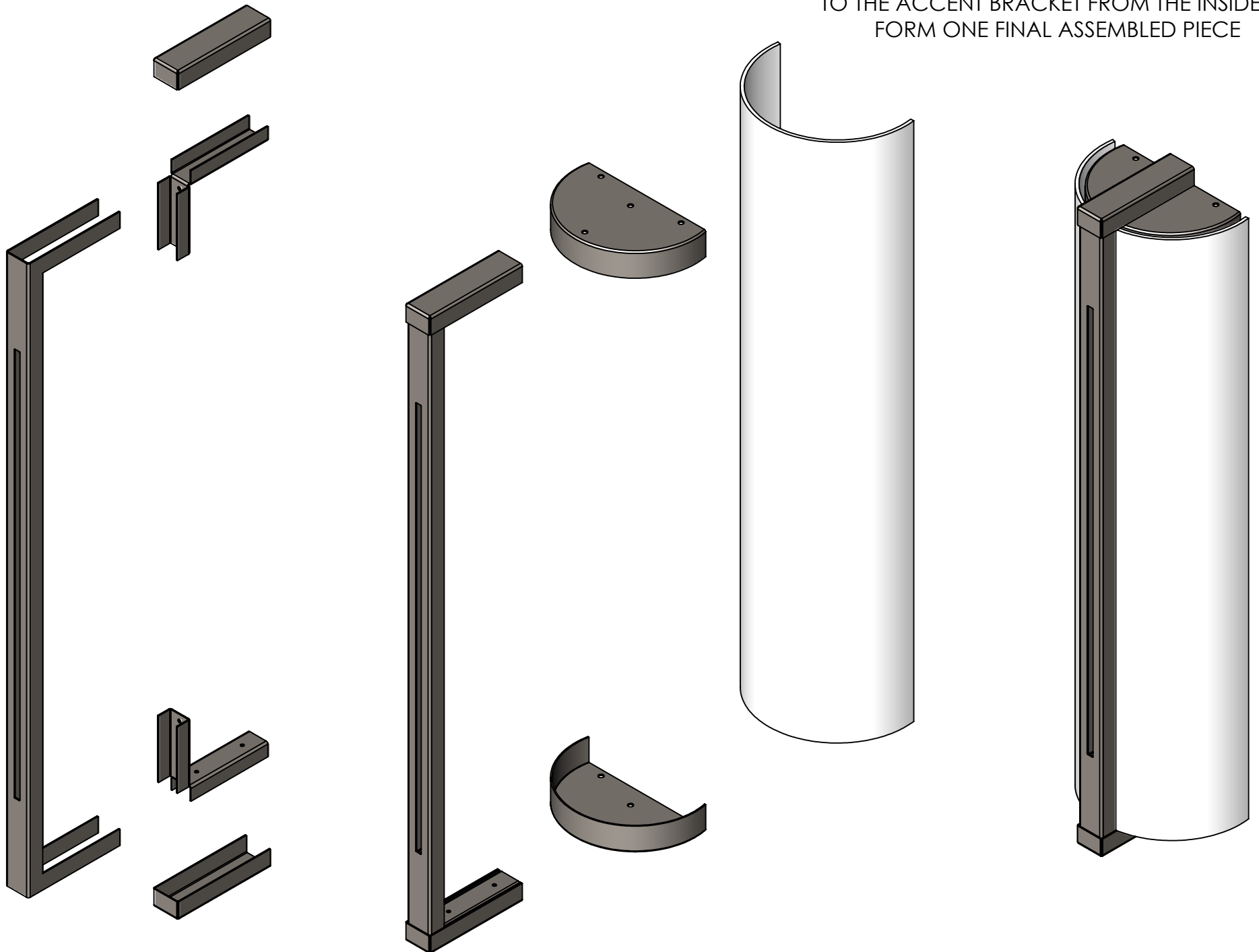

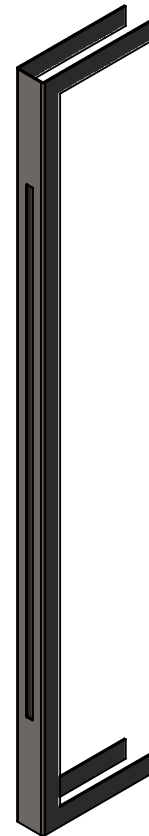
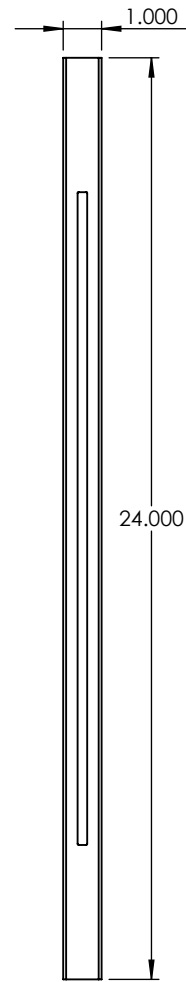
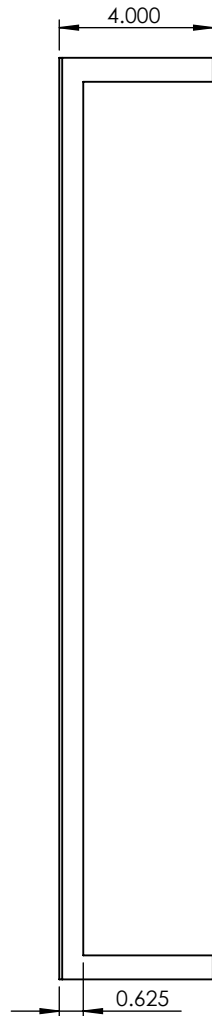
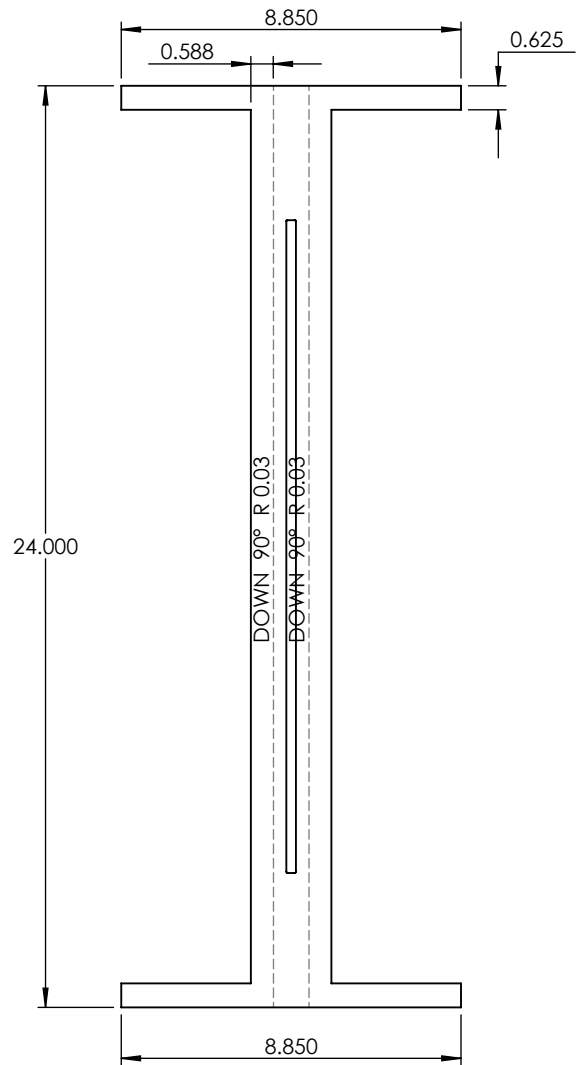

PROPRIETARY AND CONFIDENTIAL
 THE INFORMATION CONTAINED IN THIS DRAWING IS THE SOLE PROPERTY OF <INSERT COMPANY NAME HERE>. ANY REPRODUCTION IN PART OR AS A WHOLE WITHOUT THE WRITTEN PERMISSION OF <INSERT COMPANY NAME HERE> IS PROHIBITED.

		UNLESS OTHERWISE SPECIFIED:		NAME	DATE
		DIMENSIONS ARE IN INCHES	DRAWN		
		TOLERANCES:	CHECKED		
		FRACTIONAL ±	ENG APPR.		
		ANGULAR: MACH ± BEND ±	MFG APPR.		
		TWO PLACE DECIMAL ±	Q.A.		
		THREE PLACE DECIMAL ±	COMMENTS:		
		INTERPRET GEOMETRIC TOLERANCING PER:			
		MATERIAL			
	NEXT ASSY	FINISH			
		USED ON			
	APPLICATION	DO NOT SCALE DRAWING			

18 GAUGE		
TITLE:		
HFU-W-SLT-24W-MN-WF-24"-DIM-35K		
SIZE	DWG. NO.	REV
A		
SCALE: 1:5	WEIGHT:	SHEET 4 OF 7

5

4

3

2

1

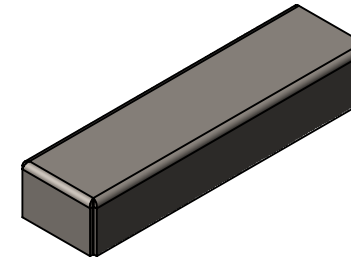
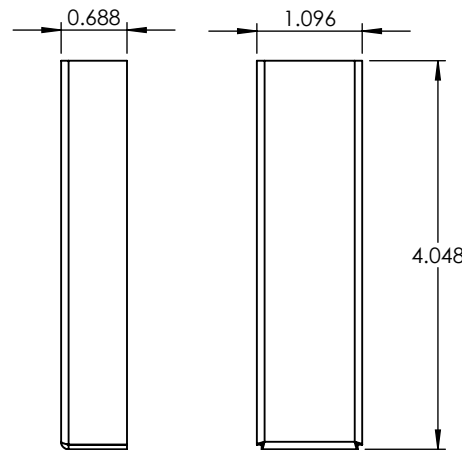
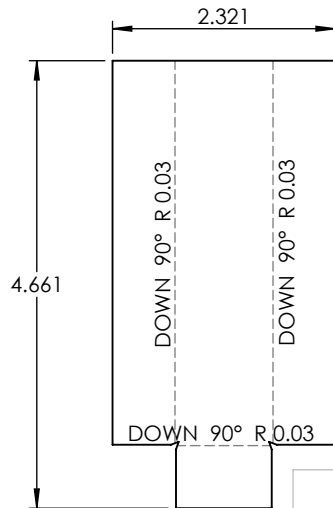
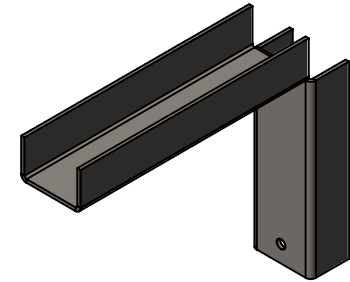
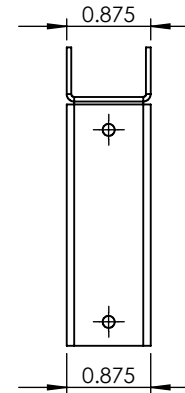
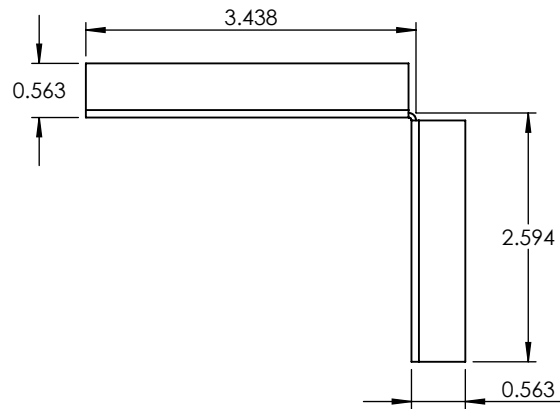
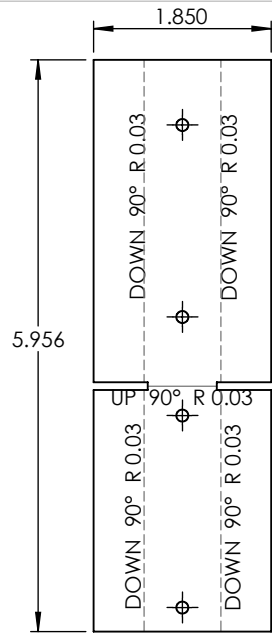

PROPRIETARY AND CONFIDENTIAL
 THE INFORMATION CONTAINED IN THIS DRAWING IS THE SOLE PROPERTY OF <INSERT COMPANY NAME HERE>. ANY REPRODUCTION IN PART OR AS A WHOLE WITHOUT THE WRITTEN PERMISSION OF <INSERT COMPANY NAME HERE> IS PROHIBITED.

		UNLESS OTHERWISE SPECIFIED:	NAME	DATE
		DIMENSIONS ARE IN INCHES	DRAWN	
		TOLERANCES:	CHECKED	
		FRACTIONAL ±	ENG APPR.	
		ANGULAR: MACH ± BEND ±	MFG APPR.	
		TWO PLACE DECIMAL ±	Q.A.	
		THREE PLACE DECIMAL ±	COMMENTS:	
		INTERPRET GEOMETRIC TOLERANCING PER:		
		MATERIAL		
NEXT ASSY	USED ON	FINISH		
APPLICATION		DO NOT SCALE DRAWING		

18 GAUGE		
TITLE:		
HFU-W-SLT-24W-MN-WF-24"-DIM-35K		
SIZE	DWG. NO.	REV
A		
SCALE: 1:2	WEIGHT:	SHEET 5 OF 7

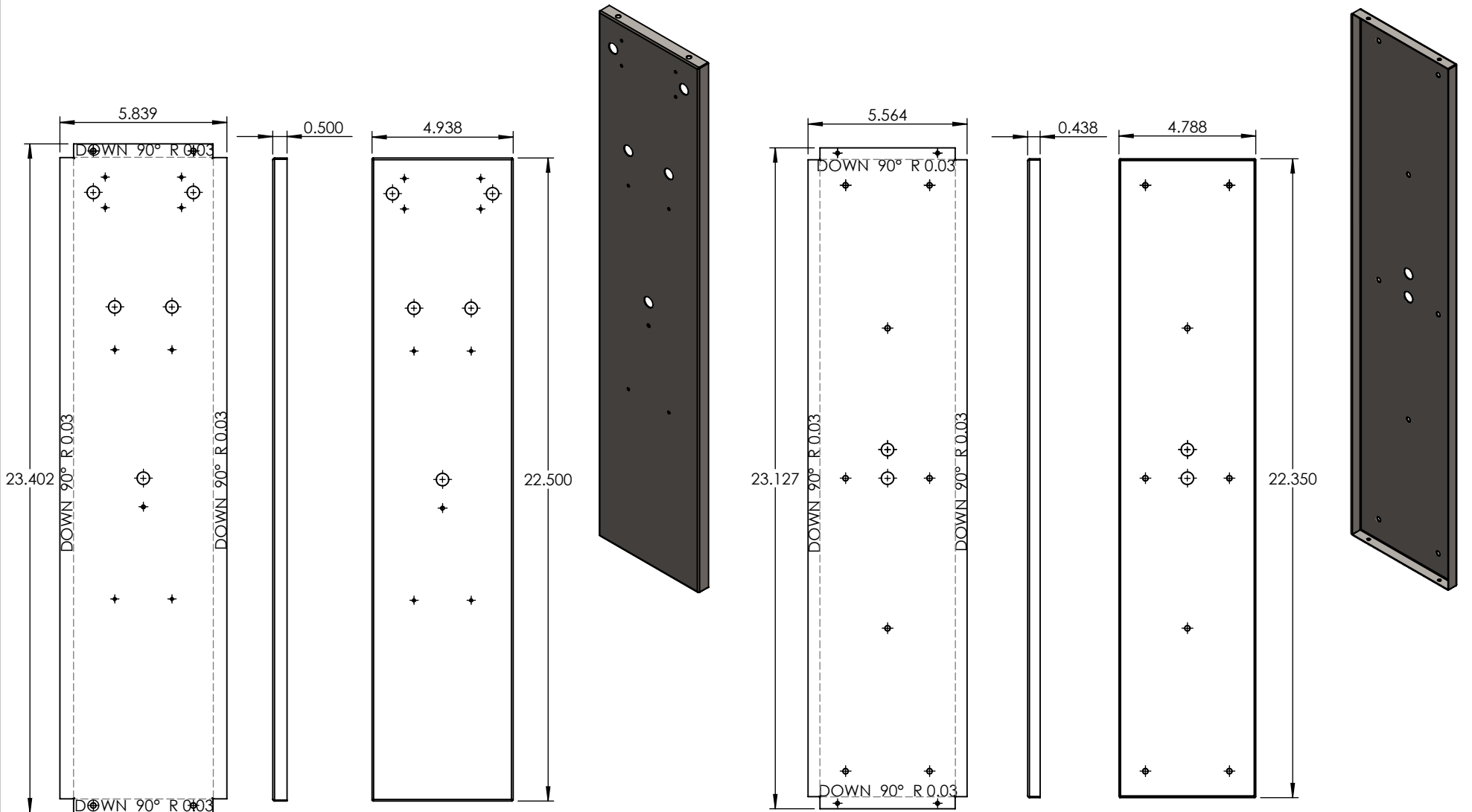

PROPRIETARY AND CONFIDENTIAL
 THE INFORMATION CONTAINED IN THIS DRAWING IS THE SOLE PROPERTY OF <INSERT COMPANY NAME HERE>. ANY REPRODUCTION IN PART OR AS A WHOLE WITHOUT THE WRITTEN PERMISSION OF <INSERT COMPANY NAME HERE> IS PROHIBITED.

		UNLESS OTHERWISE SPECIFIED:		NAME	DATE
		DIMENSIONS ARE IN INCHES	DRAWN		
		TOLERANCES:	CHECKED		
		FRACTIONAL ±	ENG APPR.		
		ANGULAR: MACH ± BEND ±	MFG APPR.		
		TWO PLACE DECIMAL ±	Q.A.		
		THREE PLACE DECIMAL ±	COMMENTS:		
		INTERPRET GEOMETRIC TOLERANCING PER:			
		MATERIAL			
		FINISH			
NEXT ASSY	USED ON				
APPLICATION		DO NOT SCALE DRAWING			

22 GAUGE		
TITLE:		
HFU-W-SLT-24W-MN-WF-24"-DIM-35K		
SIZE	DWG. NO.	REV
A		
SCALE: 1:5	WEIGHT:	SHEET 6 OF 7

ITEM NO.	PART NUMBER	DESCRIPTION	QTY.
1	HFU-W-SLT-24W-MN-WF-TBL-24"-DIM-35K-SPUN END CAPS	SPUN 18 GAUGE	1

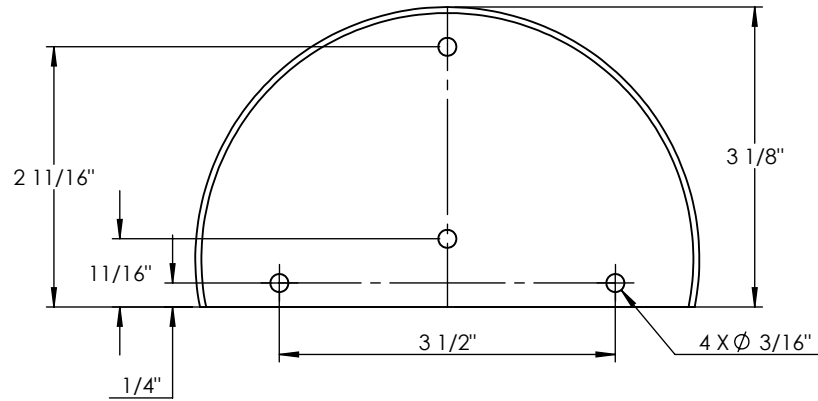
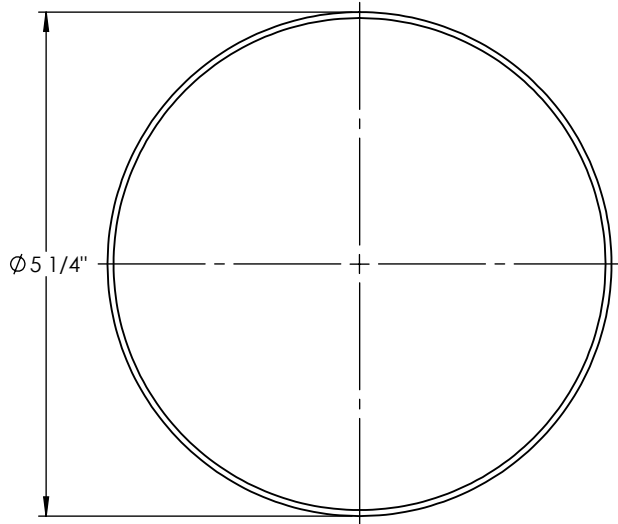
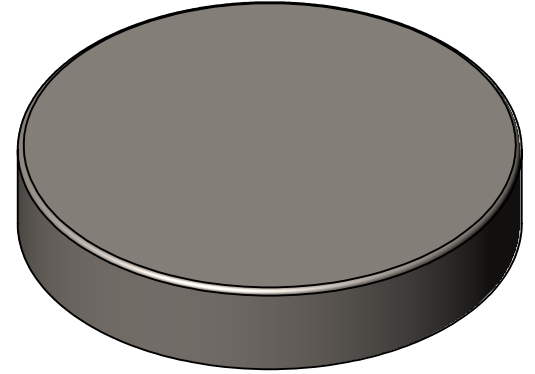
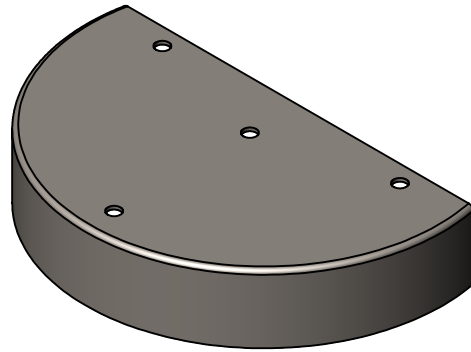

PROPRIETARY AND CONFIDENTIAL
 THE INFORMATION CONTAINED IN THIS DRAWING IS THE SOLE PROPERTY OF <INSERT COMPANY NAME HERE>. ANY REPRODUCTION IN PART OR AS A WHOLE WITHOUT THE WRITTEN PERMISSION OF <INSERT COMPANY NAME HERE> IS PROHIBITED.

		UNLESS OTHERWISE SPECIFIED:		NAME	DATE
		DIMENSIONS ARE IN INCHES	DRAWN		
		TOLERANCES:	CHECKED		
		FRACTIONAL ±	ENG APPR.		
		ANGULAR: MACH ± BEND ±	MFG APPR.		
		TWO PLACE DECIMAL ±	Q.A.		
		THREE PLACE DECIMAL ±	COMMENTS:		
		INTERPRET GEOMETRIC TOLERANCING PER:			
		MATERIAL			
NEXT ASSY	USED ON	FINISH			
APPLICATION		DO NOT SCALE DRAWING			

SPUN 18 GAUGE		
TITLE:		
HFU-W-SLT-24W-MN-WF-24"-DIM-35K		
SIZE	DWG. NO.	REV
A		
SCALE: 1:2	WEIGHT:	SHEET 7 OF 7

5

4

3

2

1