

ITEM NO.	PART NUMBER	DESCRIPTION	QTY.	CUT
1	CLG-THNBR-12"-20W-MN-WF-40K-5YR-SPUN FRAME	SPUN ALUMINUM 0.080"	1	
2	CLG-THNBR-12"-20W-MN-WF-40K-5YR-SPUN BODY ACCENT	SPUN ALUMINUM 0.080"	1	
3	CLG-THNBR-12"-20W-MN-WF-40K-5YR-SPUN BACKPLATE	SPUN 18 GAUGE	1	
4	CLG-THNBR-12"-20W-MN-WF-40K-5YR-SPUN FIREPLATE	SPUN 22 GAUGE	1	
5	CLG-THNBR-12"-20W-MN-WF-40K-5YR-ROUND PLATE	3/8" SQUARE ALUMINUM BAR	1	
6	CLG-THNBR-12"-20W-MN-WF-40K-5YR-0.625" ROUND TUBE	3/8" SQUARE ALUMINUM BAR	4	
7	CLG-THNBR-12"-20W-MN-WF-40K-5YR-0.625" ROUND TUBE	3/8" SQUARE ALUMINUM BAR	4	
8	CLG-THNBR-12"-20W-MN-WF-40K-5YR-ACRYLIC LENS	ACRYLIC	1	
9	ESPEN VEL29070MVH-1	DRIVER	1	
10	AltqILED_PN1010_RevD	LED	4	

UNLESS OTHERWISE SPECIFIED:

DIMENSIONS ARE IN INCHES
 TOLERANCES:
 FRACTIONAL ± .003
 ANGULAR: MACH ± .01 BEND ±
 TWO PLACE DECIMAL ±
 THREE PLACE DECIMAL ±.001

INTERPRET GEOMETRIC
 TOLERANCING PER:

MATERIAL

FINISH

NAME DATE

DRAWN

CHECKED

ENG APPR.

MFG APPR.

Q.A.

COMMENTS:

TITLE:
 CLG-THNBR-12"-20W-MN-WF-40K-5YR

SIZE DWG. NO. REV
A TICKET 26153

SCALE: 1:7 WEIGHT: SHEET 1 OF 8



ALL BEND RADIUS .030"

APPLICATION

DO NOT SCALE DRAWING

5

4

3

2

1

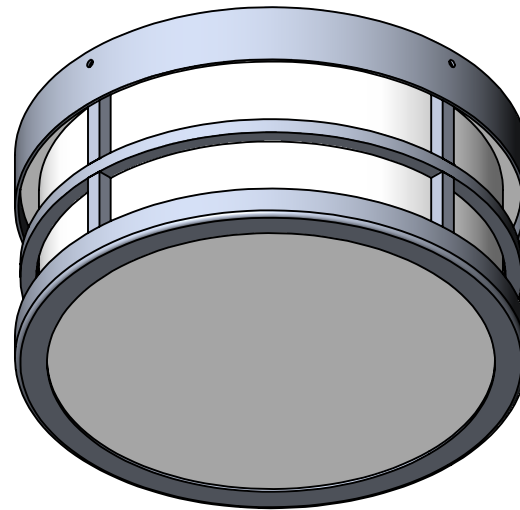
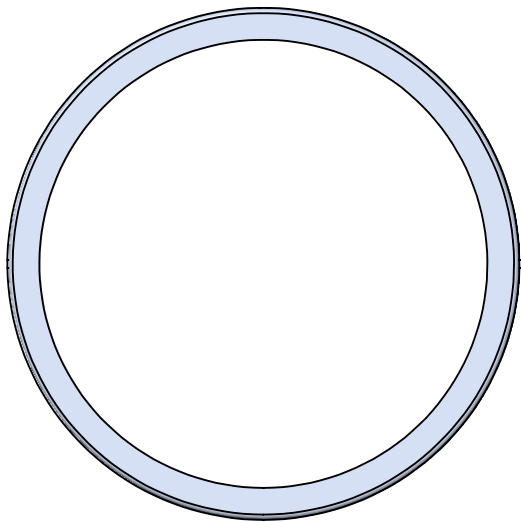
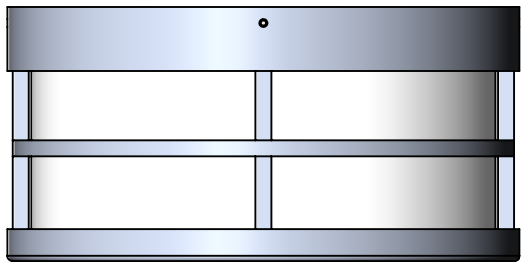
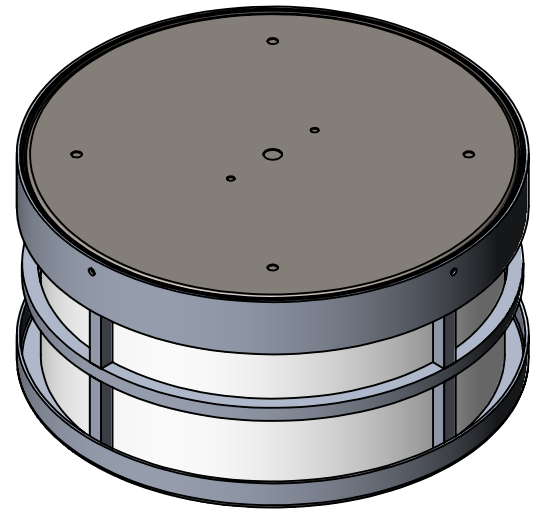
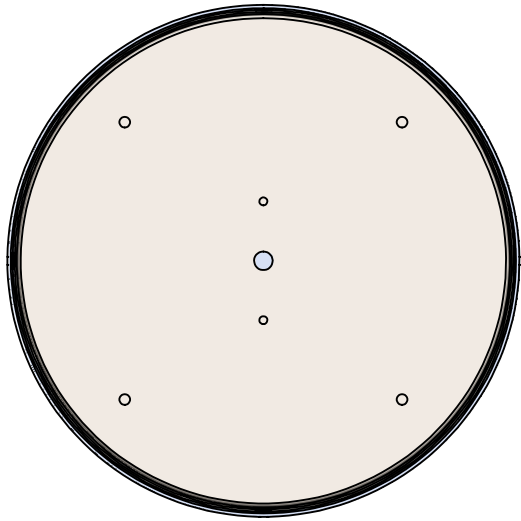

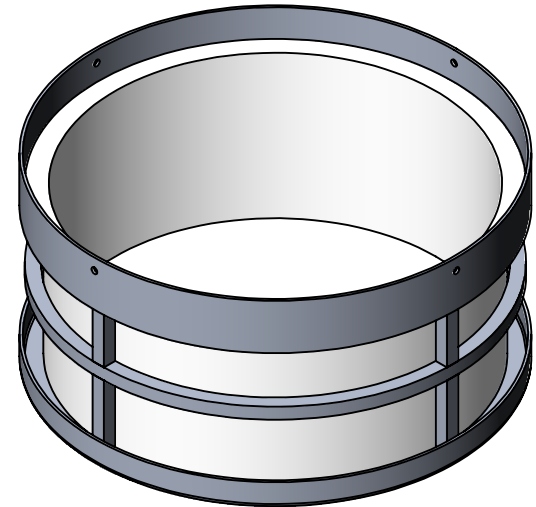
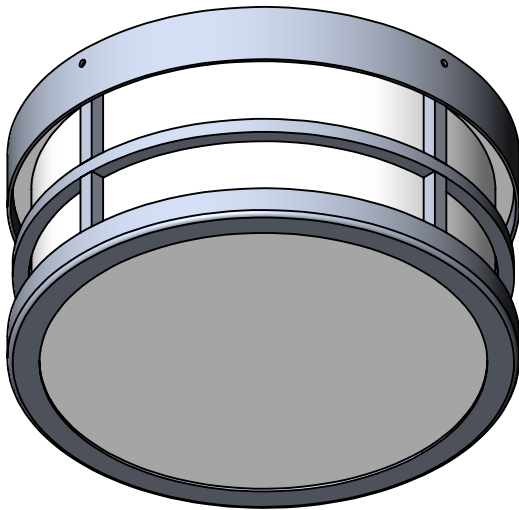
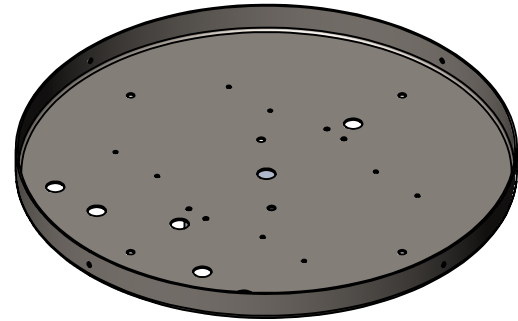
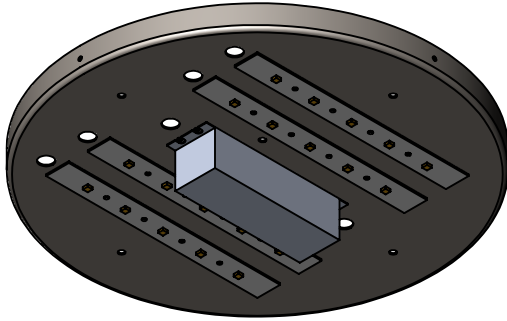
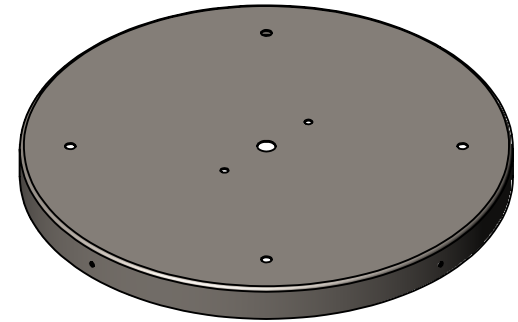
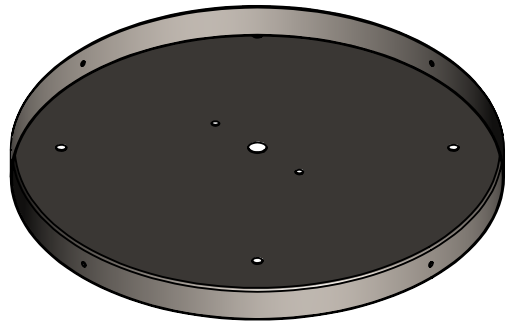

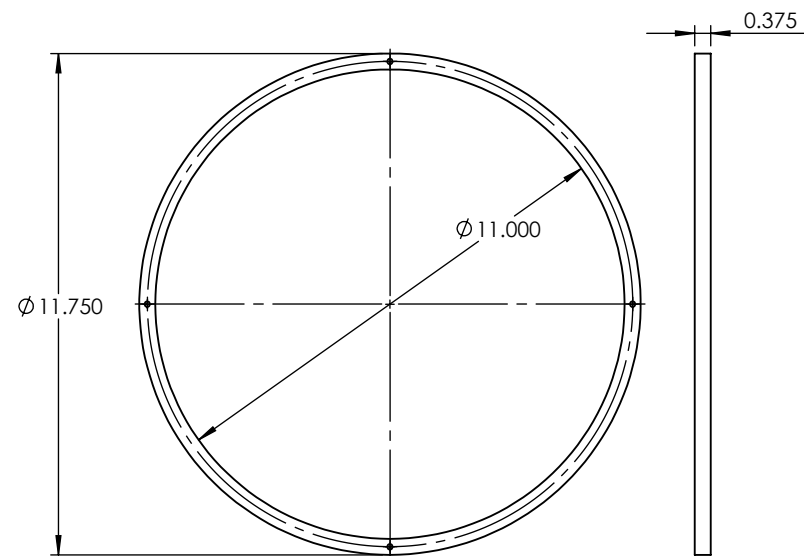
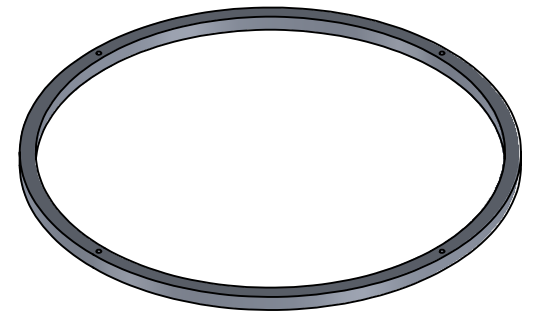
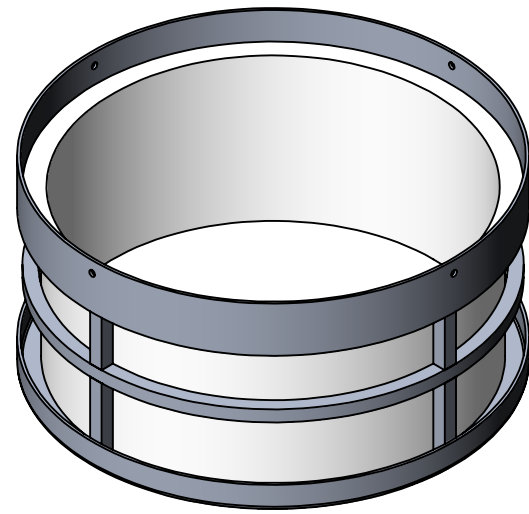
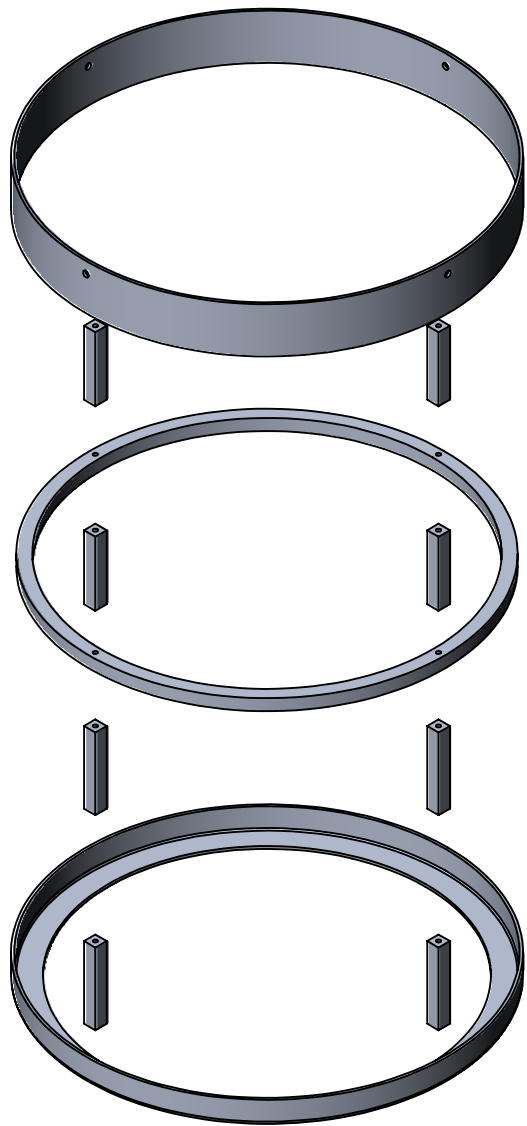

ITEM NO.	PART NUMBER	DESCRIPTION	QTY.
1	CLG-THNBR-12"-20W-MN-WF-40K-5YR-SPUN FRAME	SPUN ALUMINUM 0.080"	1

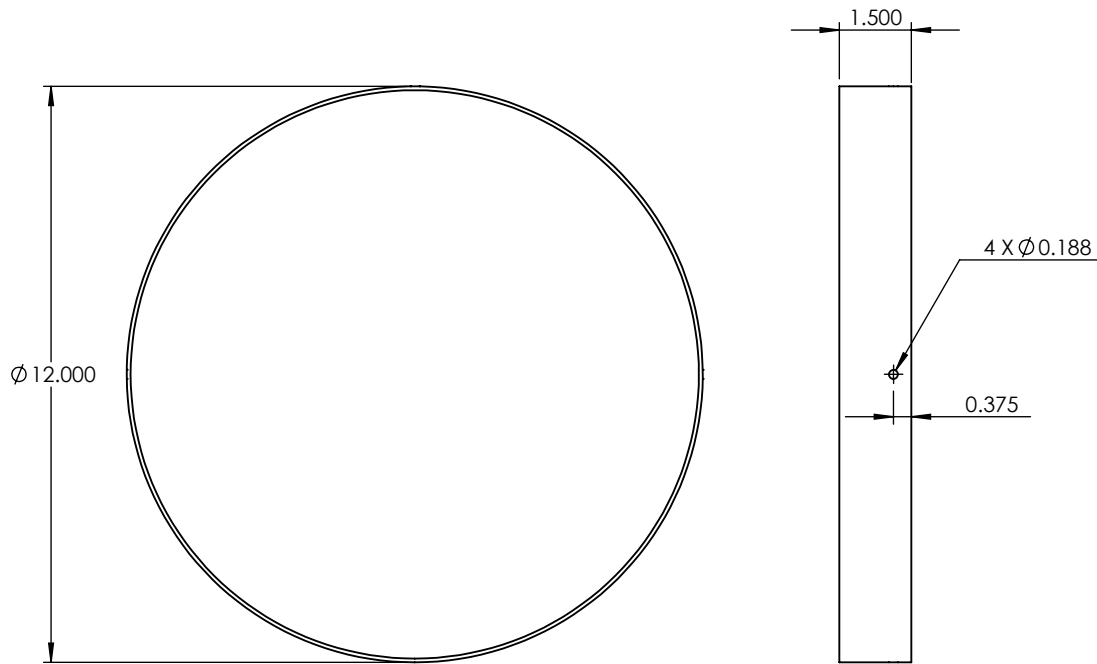
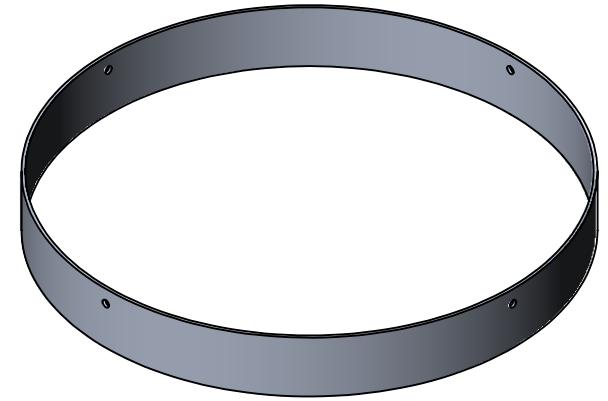

PROPRIETARY AND CONFIDENTIAL
 THE INFORMATION CONTAINED IN THIS DRAWING IS THE SOLE PROPERTY OF <INSERT COMPANY NAME HERE>. ANY REPRODUCTION IN PART OR AS A WHOLE WITHOUT THE WRITTEN PERMISSION OF <INSERT COMPANY NAME HERE> IS PROHIBITED.

		UNLESS OTHERWISE SPECIFIED:		NAME	DATE	SPUN ALUMINUM 0.080"	
		DIMENSIONS ARE IN INCHES		DRAWN		TITLE:	
		TOLERANCES:		CHECKED		CLG-THNBR-12"-20W-MN-WF-40K-5YR	
		FRACTIONAL ±		ENG APPR.		SIZE DWG. NO. REV	
		ANGULAR: MACH ± BEND ±		MFG APPR.		SCALE: 1:4 WEIGHT: SHEET 5 OF 8	
		TWO PLACE DECIMAL ±		Q.A.			
		THREE PLACE DECIMAL ±		COMMENTS:			
		INTERPRET GEOMETRIC TOLERANCING PER:					
		MATERIAL					
	NEXT ASSY	USED ON	FINISH				
	APPLICATION		DO NOT SCALE DRAWING				

5

4

3

2

1

ITEM NO.	PART NUMBER	DESCRIPTION	QTY.
1	STN-12-WL-1RG-25W-TBK-A-DIM-WET-30K-SPUN FRAME	SPUN ALUMINUM 0.080"	1

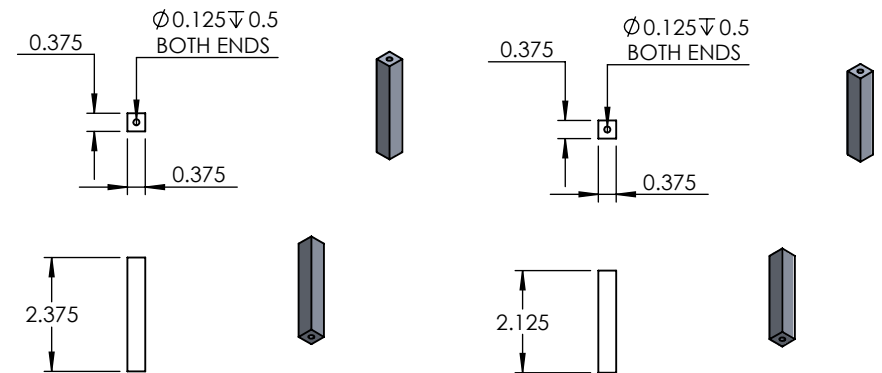
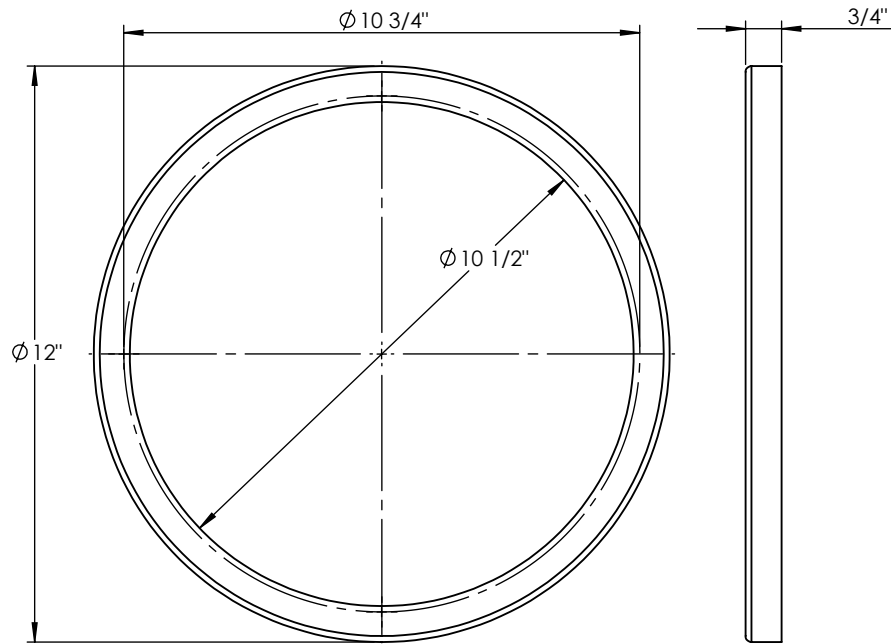
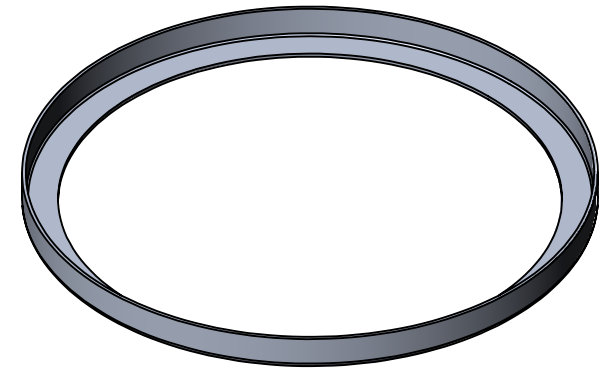

PROPRIETARY AND CONFIDENTIAL
 THE INFORMATION CONTAINED IN THIS DRAWING IS THE SOLE PROPERTY OF <INSERT COMPANY NAME HERE>. ANY REPRODUCTION IN PART OR AS A WHOLE WITHOUT THE WRITTEN PERMISSION OF <INSERT COMPANY NAME HERE> IS PROHIBITED.

UNLESS OTHERWISE SPECIFIED:		NAME	DATE
DIMENSIONS ARE IN INCHES		DRAWN	
TOLERANCES:		CHECKED	
FRACTIONAL ±		ENG APPR.	
ANGULAR: MACH ± BEND ±		MFG APPR.	
TWO PLACE DECIMAL ±		Q.A.	
THREE PLACE DECIMAL ±		COMMENTS:	
INTERPRET GEOMETRIC TOLERANCING PER:			
MATERIAL			
FINISH			
NEXT ASSY	USED ON		
APPLICATION	DO NOT SCALE DRAWING		

SPUN ALUMINUM 0.080"
 TITLE:
 CLG-THNBR-12"-20W-MN-WF-40K-5YR

SIZE	DWG. NO.	REV
A		
SCALE: 1:4	WEIGHT:	SHEET 6 OF 8

5

4

3

2

1

ITEM NO.	PART NUMBER	DESCRIPTION	QTY.
1	STN-12-WL-1RG-25W-TBK-A-DIM-WET-30K-SPUN BACKPLATE	SPUN 18 GAUGE	1

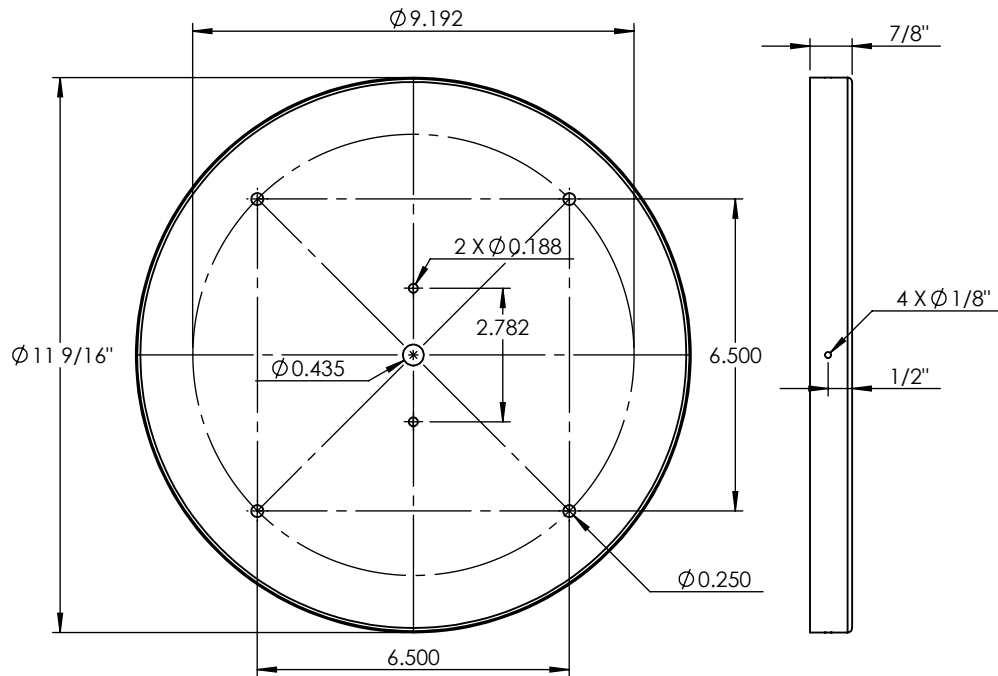
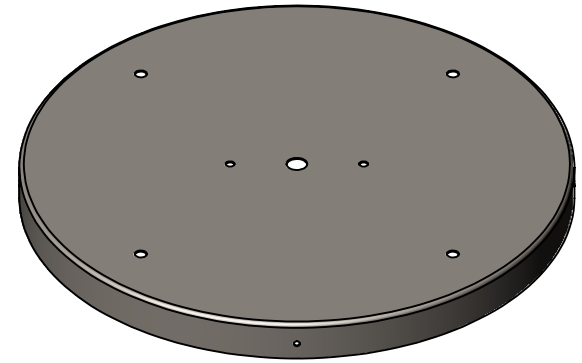

PROPRIETARY AND CONFIDENTIAL
 THE INFORMATION CONTAINED IN THIS DRAWING IS THE SOLE PROPERTY OF <INSERT COMPANY NAME HERE>. ANY REPRODUCTION IN PART OR AS A WHOLE WITHOUT THE WRITTEN PERMISSION OF <INSERT COMPANY NAME HERE> IS PROHIBITED.

		UNLESS OTHERWISE SPECIFIED:		NAME	DATE
		DIMENSIONS ARE IN INCHES			
		TOLERANCES:			
		FRACTIONAL ±			
		ANGULAR: MACH ± BEND ±			
		TWO PLACE DECIMAL ±			
		THREE PLACE DECIMAL ±			
		INTERPRET GEOMETRIC TOLERANCING PER:			
		MATERIAL			
		FINISH			
NEXT ASSY	USED ON				
APPLICATION		DO NOT SCALE DRAWING			

SPUN 22 GAUGE		
TITLE:		
CLG-THNBR-12"-20W-MN-WF-40K-5YR		
SIZE	DWG. NO.	REV
A		
SCALE: 1:4	WEIGHT:	SHEET 8 OF 8

5

4

3

2

1