

ITEM NO.	PART NUMBER	DESCRIPTION	QTY.	CUT
1	VRB-42-24W-BLK-WF-35K-CYLINDER TUBE	8" CYLINDER TUBE	1	
2	VRB-42-24W-BLK-WF-35K-ANCHOR PLATE	ALUMINUM 0.500" PLATE	1	
3	VRB-42-24W-BLK-WF-35K-ANCHOR PLATE TAB	ALUMINUM 0.500" PLATE	4	
4	VRB-42-24W-BLK-WF-35K-CAP MOUNT PLATE	ALUMINUM 0.500" PLATE	1	
5	VRB-42-24W-BLK-WF-35K-TUBE FLANGE	ALUMINUM 0.250" PLATE	1	
6	VRB-42-24W-BLK-WF-35K-SPUN INNER CAP	ALUMINUM 0.125" PLATE	1	
7	VRB-42-24W-BLK-WF-35K-LED TUBE PLATE	ALUMINUM 0.125" PLATE	1	
8	VRB-42-24W-BLK-WF-35K-SPUN TOP CAP	SPUN ALUMINUM 0.080"	1	
9	VRB-42-24W-BLK-WF-35K-SPUN CONE SEAT	SPUN ALUMINUM 0.080"	1	
10	VRB-42-24W-BLK-WF-35K-TUBE SLEEVE	SPUN ALUMINUM 0.080"	1	
11	VRB-42-24W-BLK-WF-35K-TUBE BRACKET	ALUMINUM 0.0635"	1	
12	VRB-42-24W-BLK-WF-35K-DRIVER BRACKET	ALUMINUM 0.0635"	1	
13	VRB-42-24W-BLK-WF-35K-SQUARE TUBE	1-1/2" SQUARE ALUMINUM TUBE	1	
14	VRB-42-24W-BLK-WF-35K-ACRYLIC TUBE	ACRYLIC	1	
15	VRB-42-24W-BLK-WF-35K-0.375" ROUND TUBE	3/8" THREADED ROD	1	
16	AltLED PN1012 RevE	LED	8	
17	Espen VEL19070MVH-1	DRIVER	2	

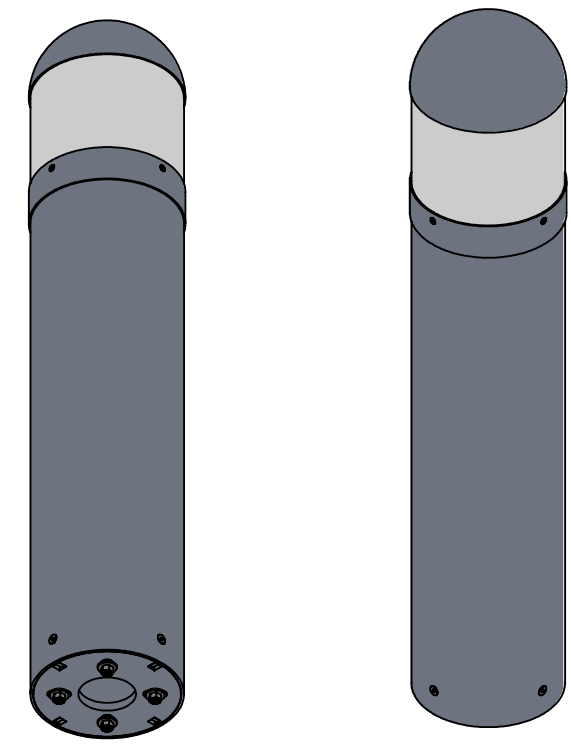

UNLESS OTHERWISE SPECIFIED:		NAME	DATE	TITLE:	
DIMENSIONS ARE IN INCHES		DRAWN		VRB-42-24W-BLK-WF-35K	
TOLERANCES:		CHECKED			
FRACTIONAL ± .003		ENG APPR.			
ANGULAR: MACH ± .01 BEND ±		MFG APPR.			
TWO PLACE DECIMAL ±		Q.A.		SIZE	DWG. NO.
THREE PLACE DECIMAL ± .001		COMMENTS:		<b>A</b>	TICKET 26048
INTERPRET GEOMETRIC TOLERANCING PER:				SCALE: 1:10	WEIGHT:
MATERIAL					SHEET 1 OF 13
FINISH					
APPLICATION					
DO NOT SCALE DRAWING					

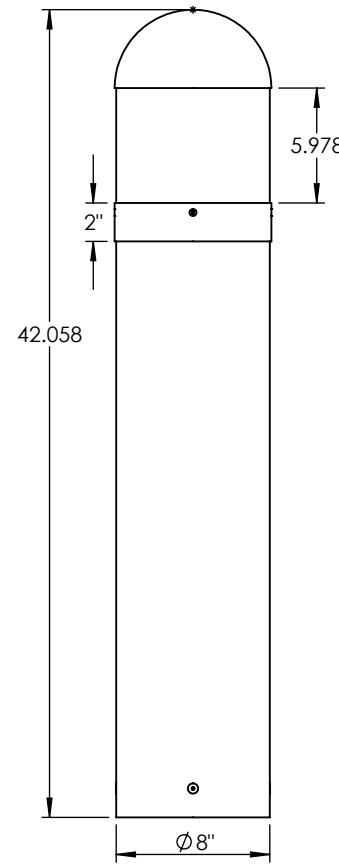
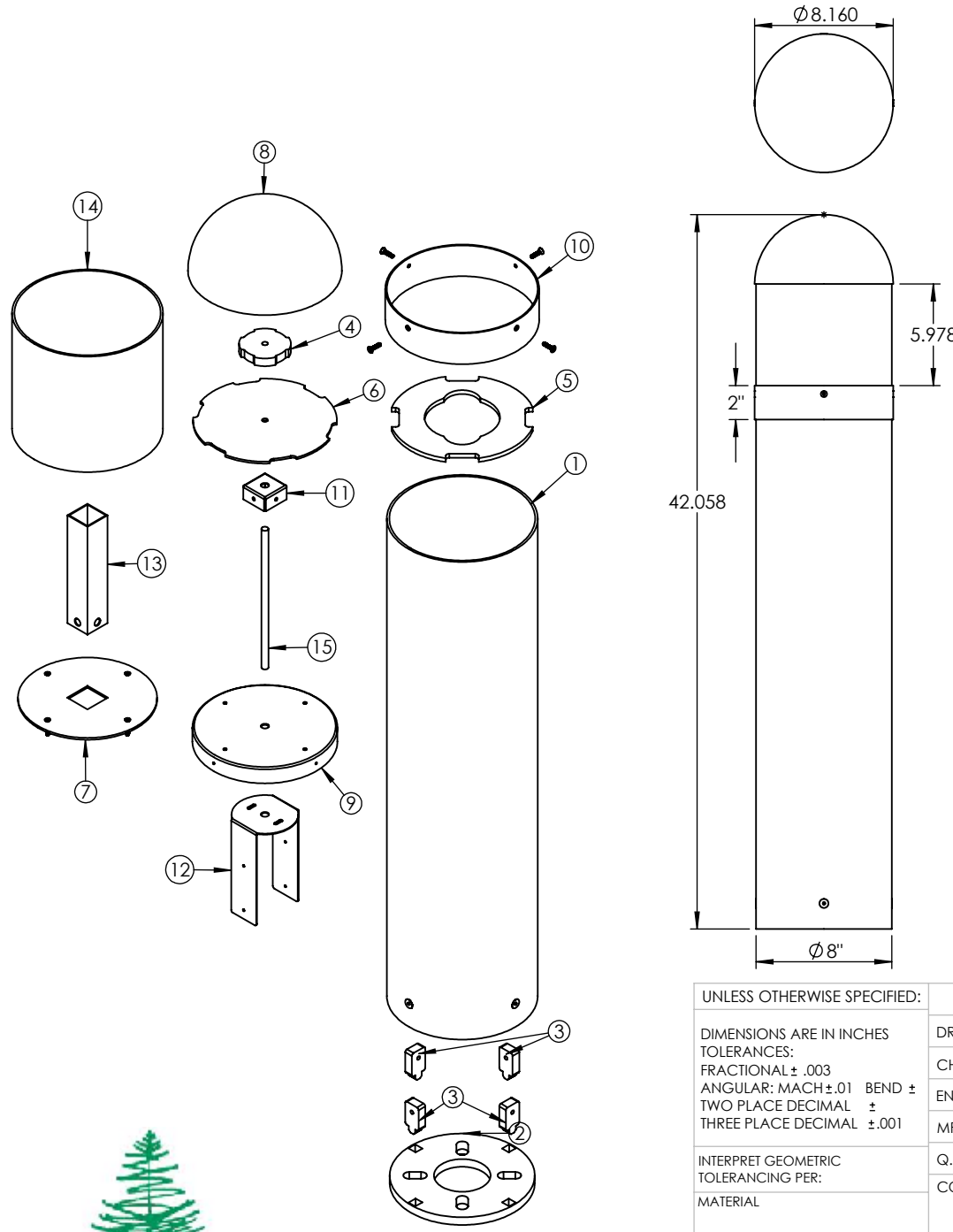

ALL BEND RADIUS .030"

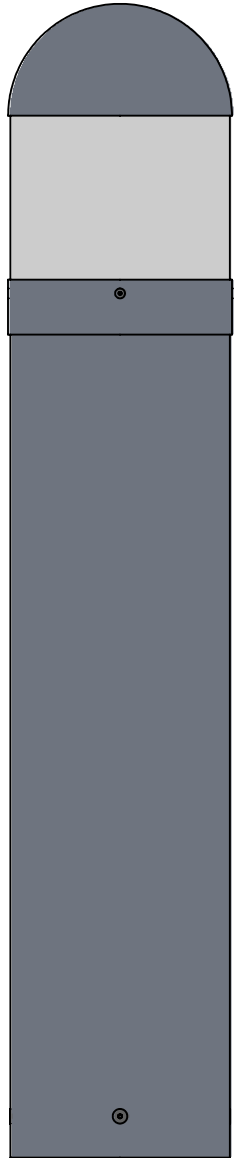
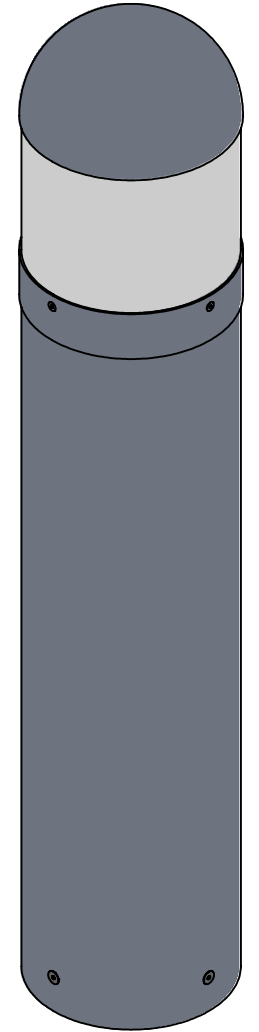
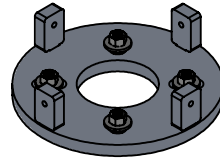
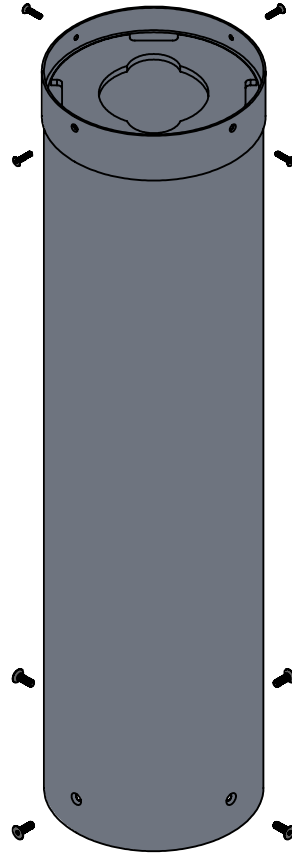
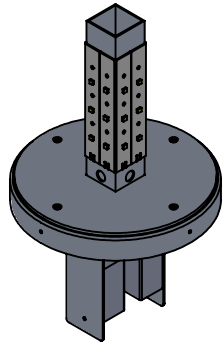
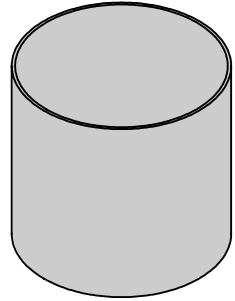
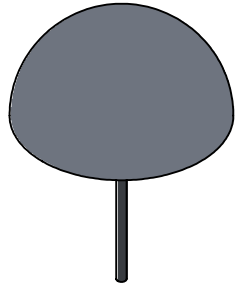
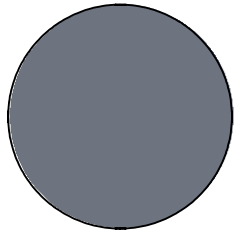

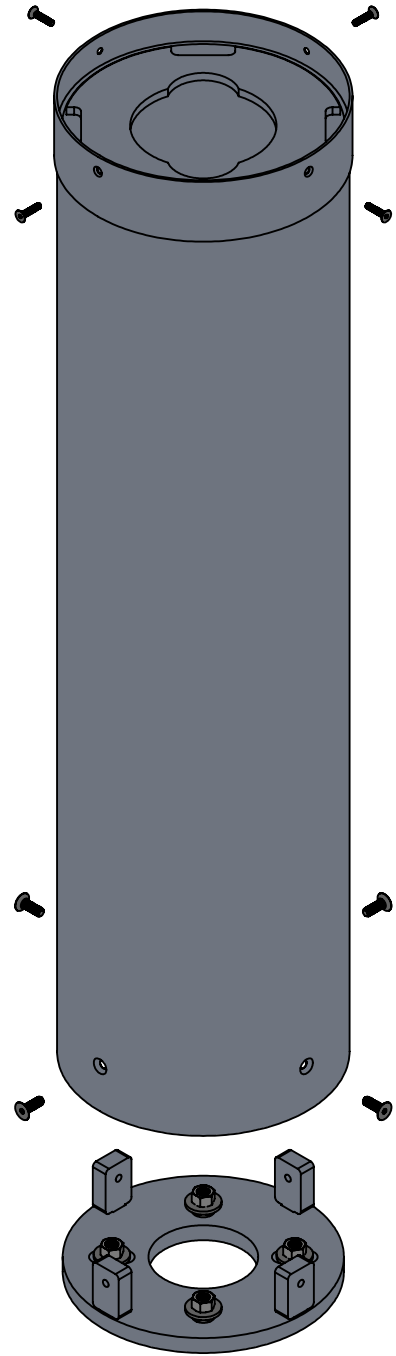
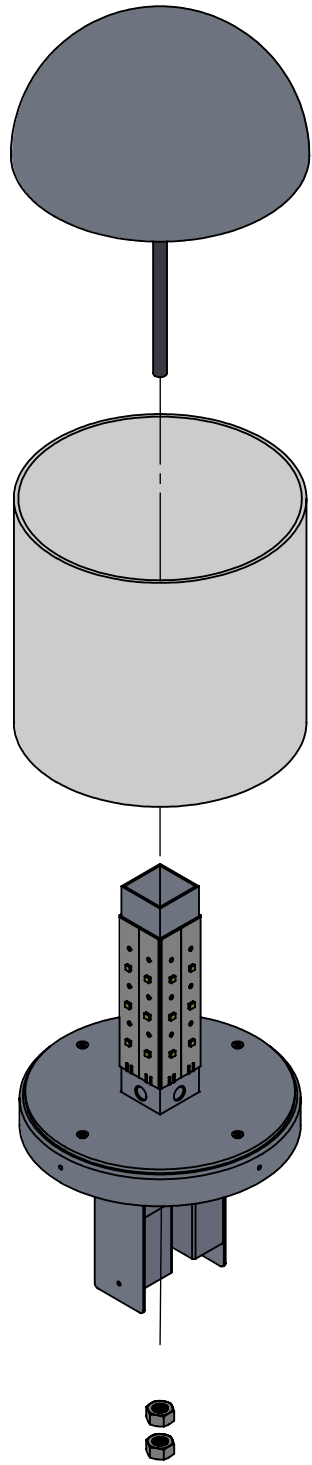

- ALL MEASUREMENTS FROM TOP RIM OF CYLINDER

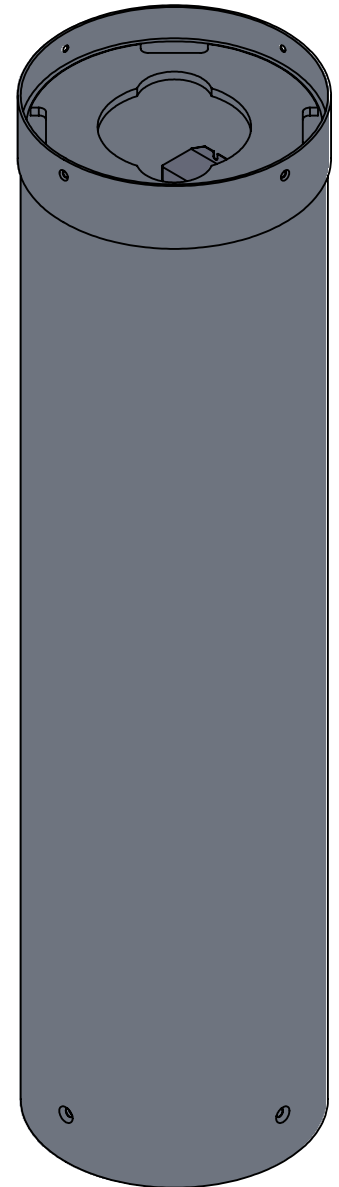
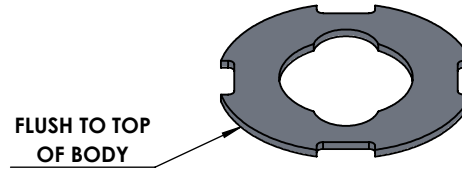
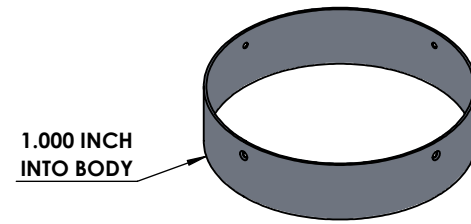
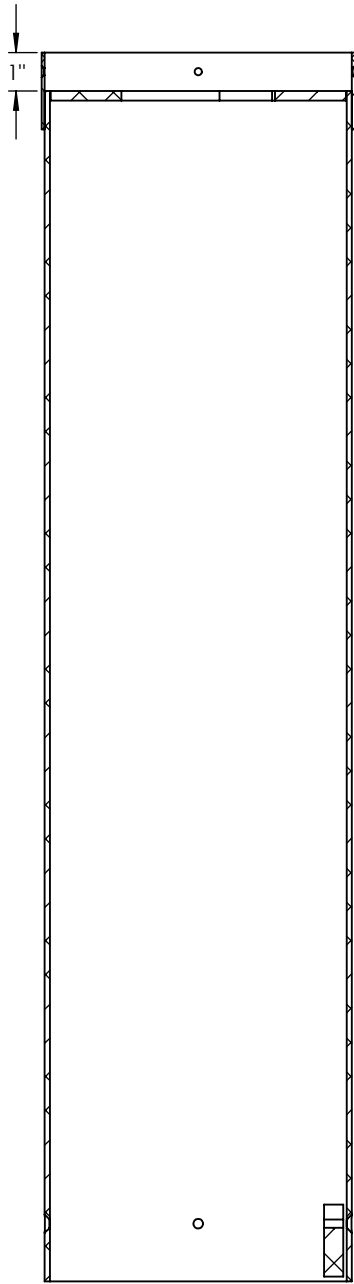
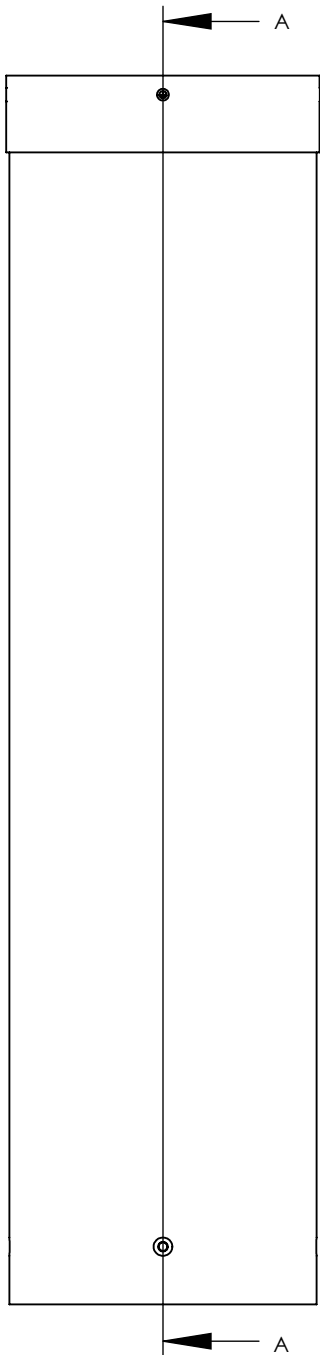

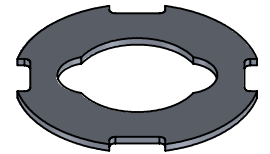
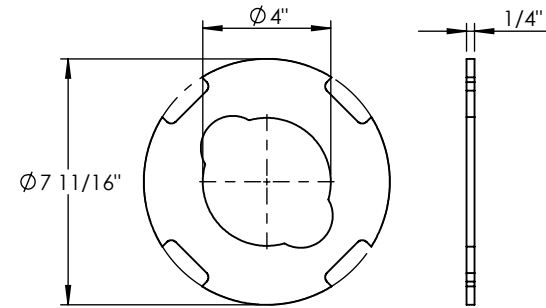
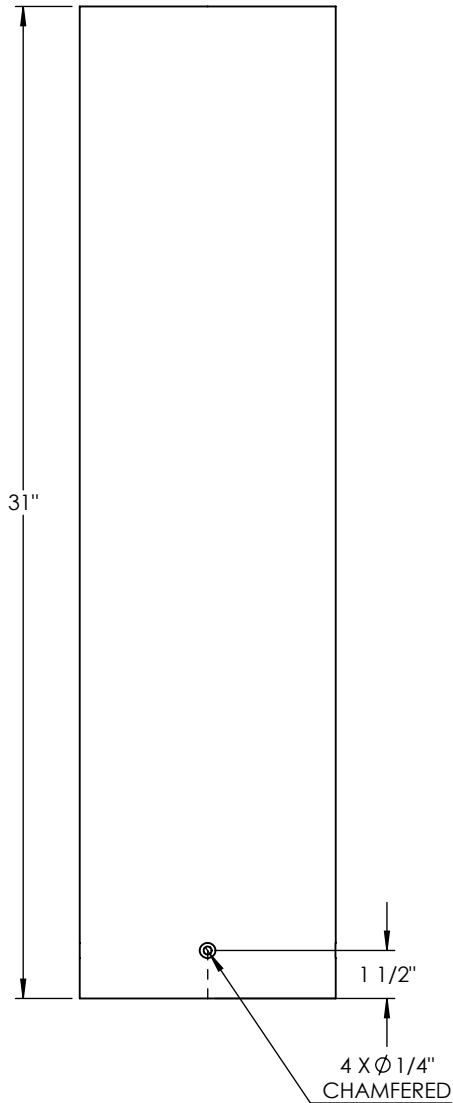
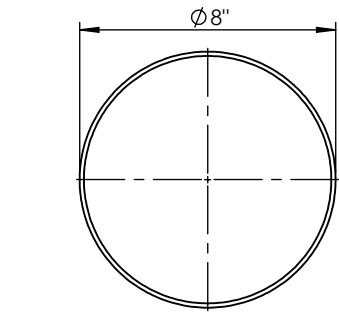

UNLESS OTHERWISE SPECIFIED:		NAME	DATE	8" CYLINDER TUBE	
DIMENSIONS ARE IN INCHES		DRAWN		TITLE:  VRB-42-24W-BLK-WF-35K	
TOLERANCES:		CHECKED			
FRACTIONAL $\pm$		ENG APPR.			
ANGULAR: MACH $\pm$ BEND $\pm$		MFG APPR.			
TWO PLACE DECIMAL $\pm$		Q.A.		SIZE	DWG. NO.
THREE PLACE DECIMAL $\pm$		COMMENTS:		<b>A</b>	
INTERPRET GEOMETRIC TOLERANCING PER:				SCALE: 1:6	WEIGHT:
MATERIAL					SHEET 5 OF 13
FINISH					
DO NOT SCALE DRAWING					

5

4

3

2

1

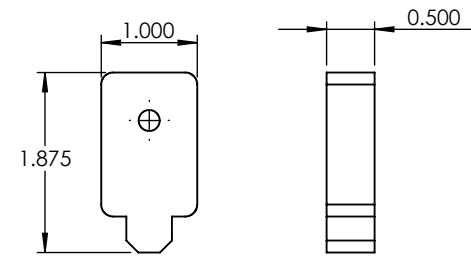
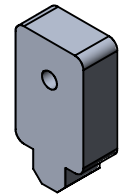
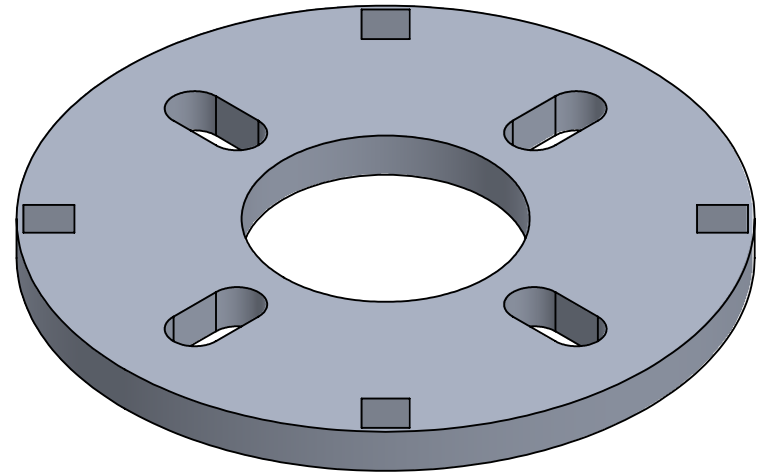
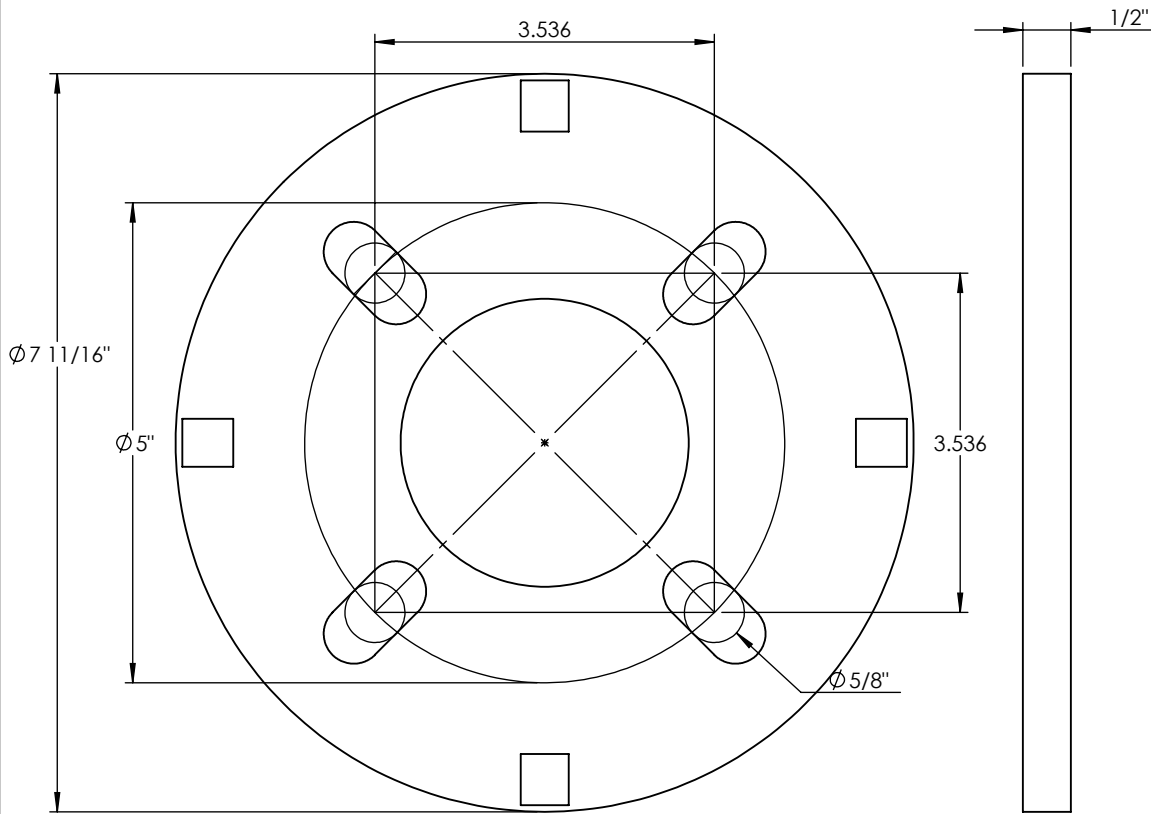

		UNLESS OTHERWISE SPECIFIED:	NAME	DATE	ALUMINUM 0.500" PLATE	
		DIMENSIONS ARE IN INCHES	DRAWN		TITLE:	
		TOLERANCES:	CHECKED		VRB-42-24W-BLK-WF-35K	
		FRACTIONAL ±	ENG APPR.		SIZE	DWG. NO.
		ANGULAR: MACH ± BEND ±	MFG APPR.		<b>A</b>	REV
		TWO PLACE DECIMAL ±	Q.A.		SCALE: 1:2	WEIGHT:
		THREE PLACE DECIMAL ±	COMMENTS:		SHEET 6 OF 13	
		INTERPRET GEOMETRIC TOLERANCING PER:				
		MATERIAL				
NEXT ASSY	USED ON	FINISH				
APPLICATION		DO NOT SCALE DRAWING				

5

4

3

2

1

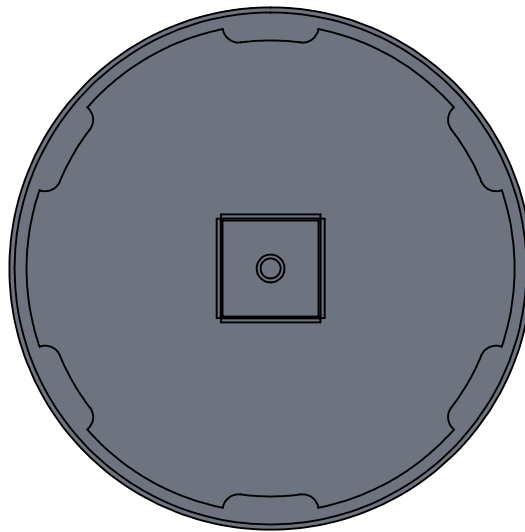
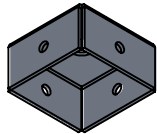
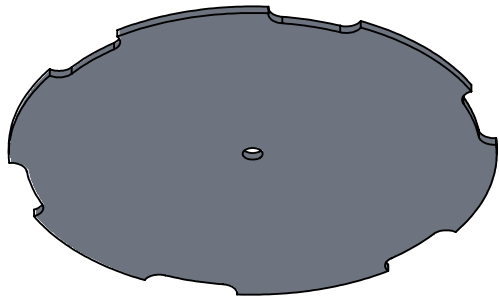
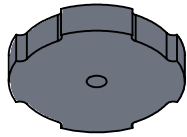
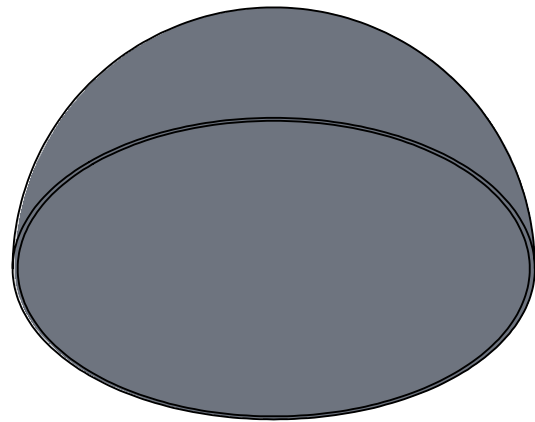

WELDED ALL AROUND

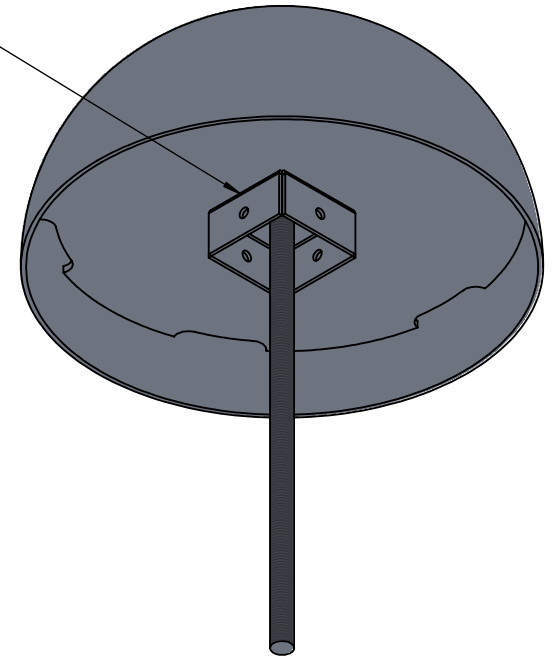

**PROPRIETARY AND CONFIDENTIAL**  
 THE INFORMATION CONTAINED IN THIS DRAWING IS THE SOLE PROPERTY OF <INSERT COMPANY NAME HERE>. ANY REPRODUCTION IN PART OR AS A WHOLE WITHOUT THE WRITTEN PERMISSION OF <INSERT COMPANY NAME HERE> IS PROHIBITED.

		UNLESS OTHERWISE SPECIFIED:		NAME	DATE		
		DIMENSIONS ARE IN INCHES	DRAWN			TITLE:	
		TOLERANCES:	CHECKED			VRB-42-24W-BLK-WF-35K	
		FRACTIONAL ±	ENG APPR.			SIZE	DWG. NO.
		ANGULAR: MACH ± BEND ±	MFG APPR.			<b>A</b>	REV
		TWO PLACE DECIMAL ±	Q.A.			SCALE: 1:3	WEIGHT:
		THREE PLACE DECIMAL ±	COMMENTS:				SHEET 7 OF 13
		INTERPRET GEOMETRIC TOLERANCING PER:					
		MATERIAL					
	NEXT ASSY	FINISH					
		USED ON					
	APPLICATION	DO NOT SCALE DRAWING					

5

4

3

2

1

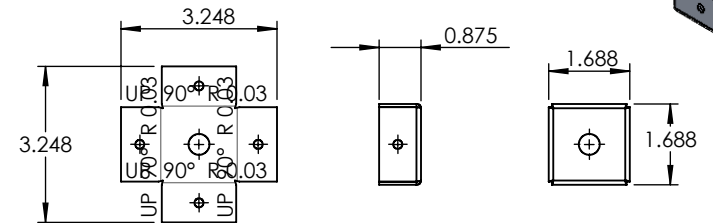
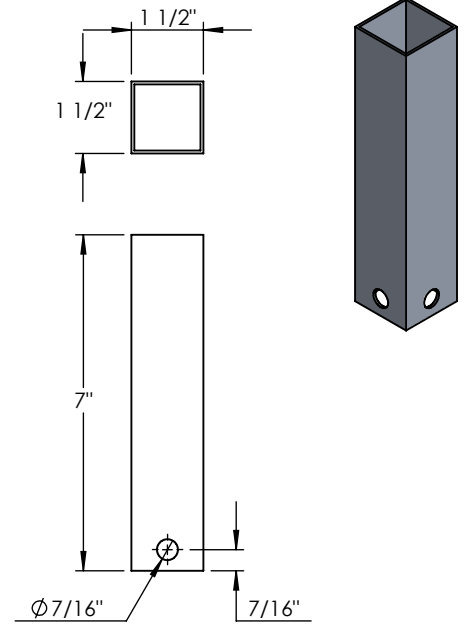
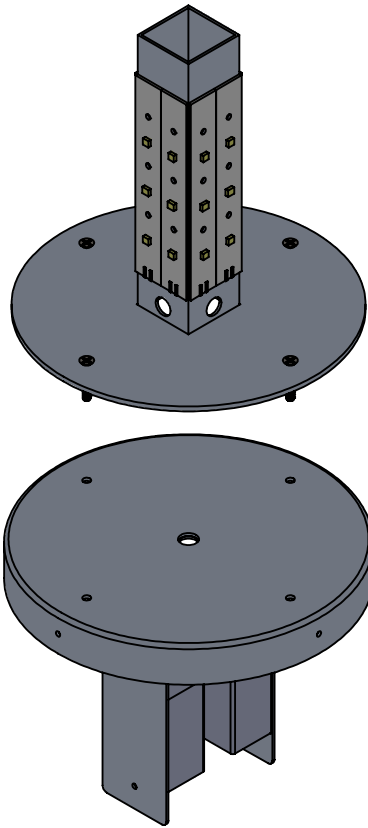
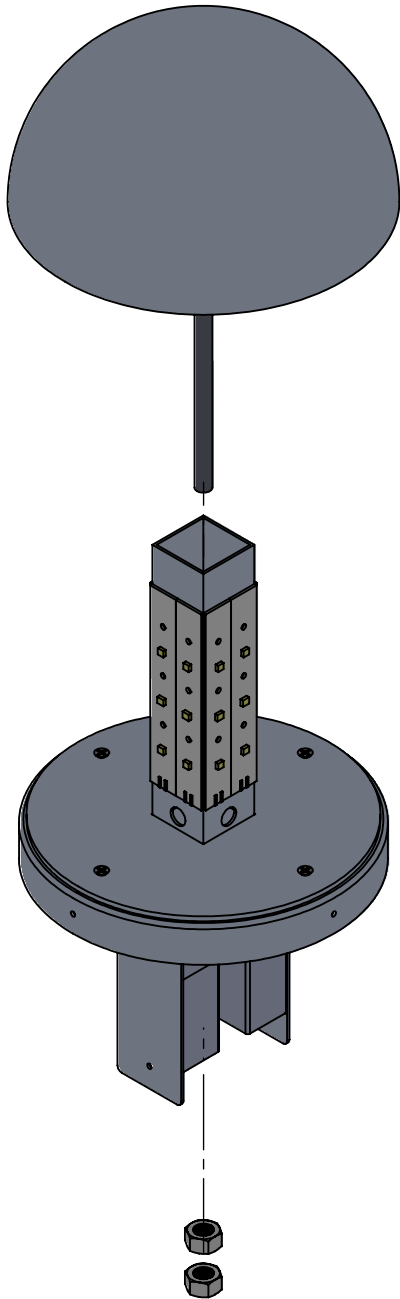

**PROPRIETARY AND CONFIDENTIAL**  
 THE INFORMATION CONTAINED IN THIS DRAWING IS THE SOLE PROPERTY OF <INSERT COMPANY NAME HERE>. ANY REPRODUCTION IN PART OR AS A WHOLE WITHOUT THE WRITTEN PERMISSION OF <INSERT COMPANY NAME HERE> IS PROHIBITED.

		UNLESS OTHERWISE SPECIFIED:	NAME	DATE
		DIMENSIONS ARE IN INCHES	DRAWN	
		TOLERANCES:	CHECKED	
		FRACTIONAL ±	ENG APPR.	
		ANGULAR: MACH ± BEND ±	MFG APPR.	
		TWO PLACE DECIMAL ±	Q.A.	
		THREE PLACE DECIMAL ±	COMMENTS:	
		INTERPRET GEOMETRIC TOLERANCING PER:		
		MATERIAL		
		FINISH		
NEXT ASSY	USED ON			
APPLICATION		DO NOT SCALE DRAWING		

TITLE:		
VRB-42-24W-BLK-WF-35K		
SIZE	DWG. NO.	REV
<b>A</b>		
SCALE: 1:4	WEIGHT:	SHEET 8 OF 13

5

4

3

2

1



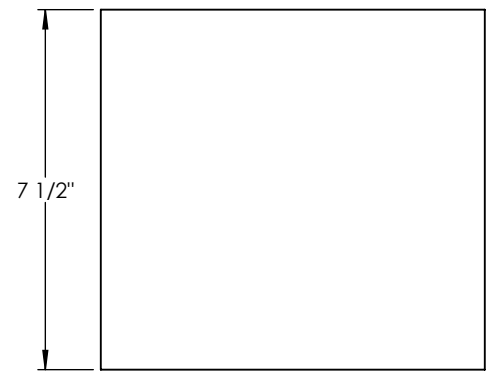
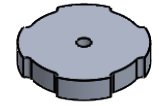
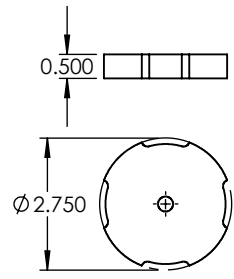
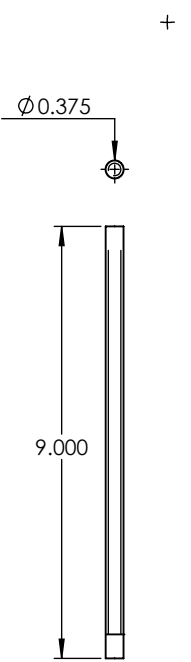
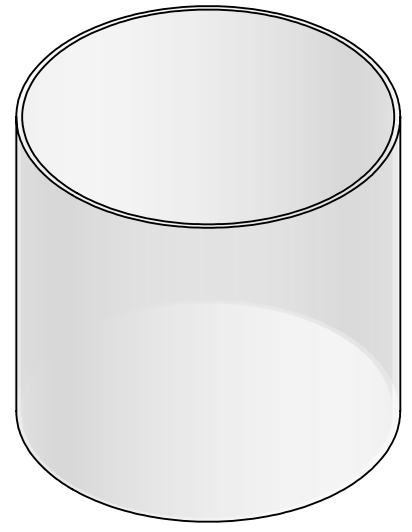
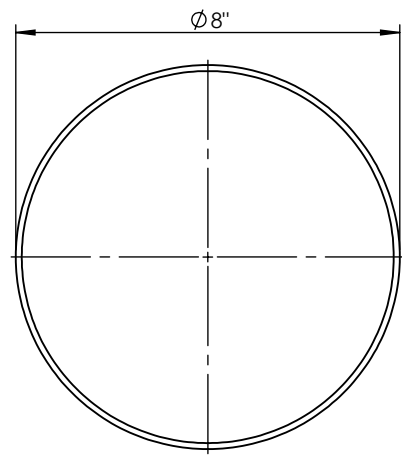
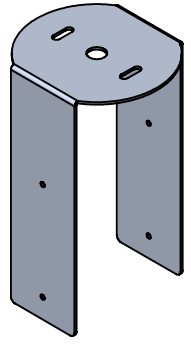
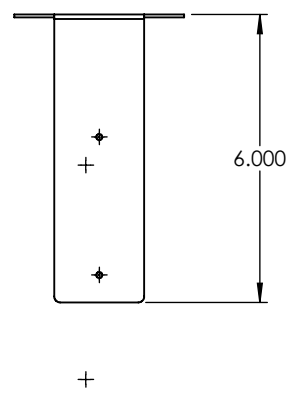
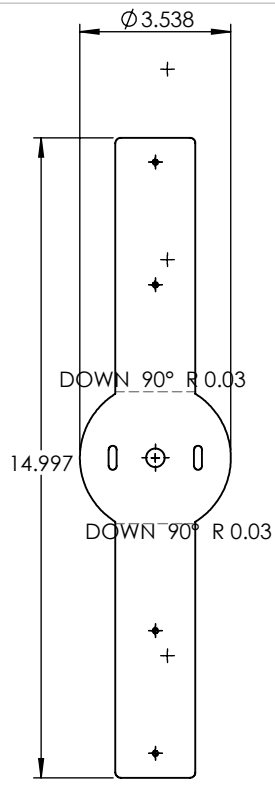

**PROPRIETARY AND CONFIDENTIAL**  
 THE INFORMATION CONTAINED IN THIS DRAWING IS THE SOLE PROPERTY OF <INSERT COMPANY NAME HERE>. ANY REPRODUCTION IN PART OR AS A WHOLE WITHOUT THE WRITTEN PERMISSION OF <INSERT COMPANY NAME HERE> IS PROHIBITED.

THREADED ROD

		UNLESS OTHERWISE SPECIFIED:		NAME	DATE
		DIMENSIONS ARE IN INCHES	DRAWN		
		TOLERANCES:	CHECKED		
		FRACTIONAL ±	ENG APPR.		
		ANGULAR: MACH ± BEND ±	MFG APPR.		
		TWO PLACE DECIMAL ±	Q.A.		
		THREE PLACE DECIMAL ±	COMMENTS:		
		INTERPRET GEOMETRIC TOLERANCING PER:			
		MATERIAL			
NEXT ASSY	USED ON	FINISH			
APPLICATION		DO NOT SCALE DRAWING			

ALUMINUM 0.0635"		
TITLE:		
VRB-42-24W-BLK-WF-35K		
SIZE	DWG. NO.	REV
<b>A</b>		
SCALE: 1:4	WEIGHT:	SHEET 9 OF 13

5

4

3

2

1

ITEM NO.	PART NUMBER	DESCRIPTION	QTY.
1	VRB-42-24W-BLK-WF-35K-SPUN TOP CAP	SPUN ALUMINUM 0.080"	1

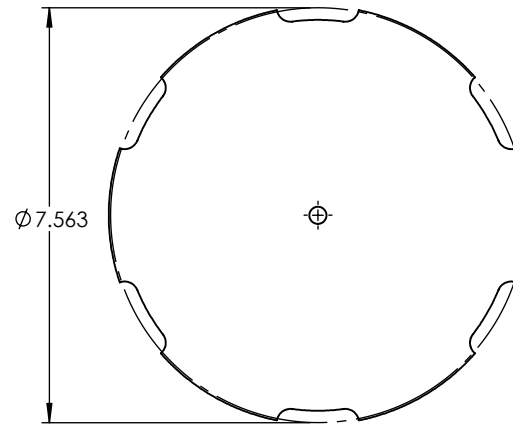
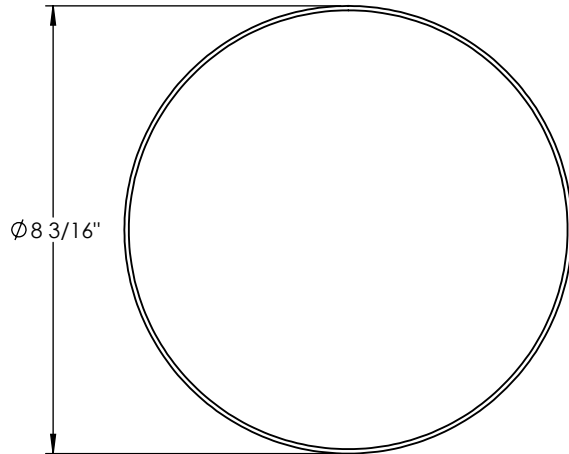
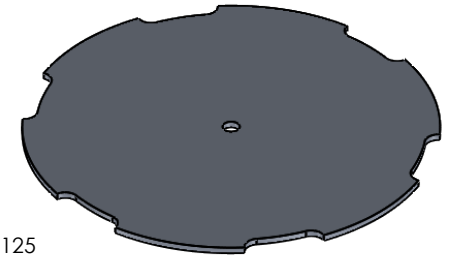
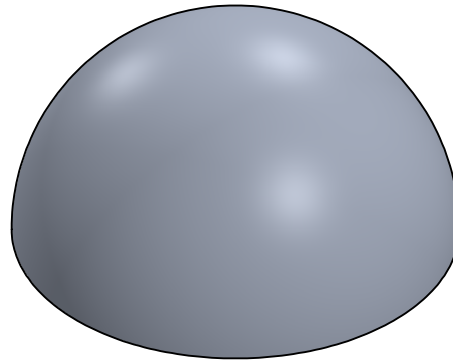
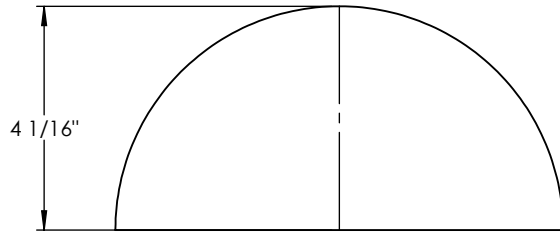

**PROPRIETARY AND CONFIDENTIAL**  
 THE INFORMATION CONTAINED IN THIS DRAWING IS THE SOLE PROPERTY OF <INSERT COMPANY NAME HERE>. ANY REPRODUCTION IN PART OR AS A WHOLE WITHOUT THE WRITTEN PERMISSION OF <INSERT COMPANY NAME HERE> IS PROHIBITED.

		UNLESS OTHERWISE SPECIFIED:	NAME	DATE
		DIMENSIONS ARE IN INCHES	DRAWN	
		TOLERANCES:	CHECKED	
		FRACTIONAL ±	ENG APPR.	
		ANGULAR: MACH ± BEND ±	MFG APPR.	
		TWO PLACE DECIMAL ±	Q.A.	
		THREE PLACE DECIMAL ±	COMMENTS:	
		INTERPRET GEOMETRIC TOLERANCING PER:		
		MATERIAL		
NEXT ASSY	USED ON	FINISH		
APPLICATION		DO NOT SCALE DRAWING		

SPUN ALUMINUM 0.080"		
TITLE:		
VRB-42-24W-BLK-WF-35K		
SIZE	DWG. NO.	REV
<b>A</b>		
SCALE: 1:3.5		WEIGHT: SHEET 10 OF 13

ITEM NO.	PART NUMBER	DESCRIPTION	QTY.
1	VRB-42-24W-BLK-WF-35K-SPUN CONE SEAT	SPUN ALUMINUM 0.080"	1

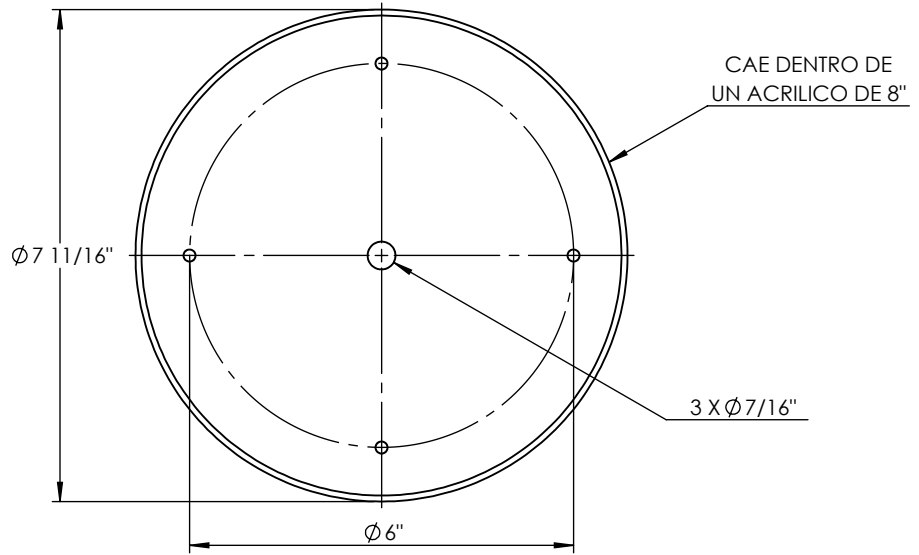
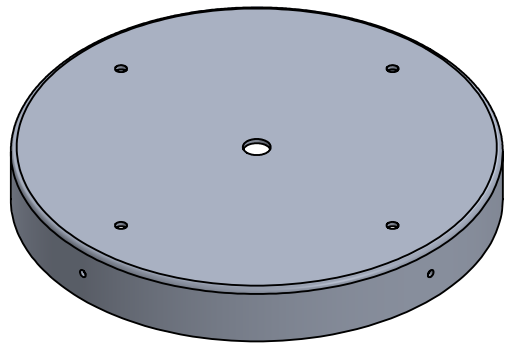
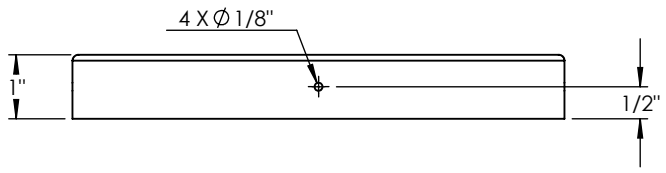

**PROPRIETARY AND CONFIDENTIAL**  
 THE INFORMATION CONTAINED IN THIS DRAWING IS THE SOLE PROPERTY OF <INSERT COMPANY NAME HERE>. ANY REPRODUCTION IN PART OR AS A WHOLE WITHOUT THE WRITTEN PERMISSION OF <INSERT COMPANY NAME HERE> IS PROHIBITED.

		UNLESS OTHERWISE SPECIFIED:		NAME	DATE
		DIMENSIONS ARE IN INCHES	DRAWN		
		TOLERANCES:	CHECKED		
		FRACTIONAL ±	ENG APPR.		
		ANGULAR: MACH ± BEND ±	MFG APPR.		
		TWO PLACE DECIMAL ±	Q.A.		
		THREE PLACE DECIMAL ±	COMMENTS:		
		INTERPRET GEOMETRIC TOLERANCING PER:			
		MATERIAL			
		FINISH			
NEXT ASSY	USED ON				
APPLICATION		DO NOT SCALE DRAWING			

SPUN ALUMINUM 0.080"		
TITLE:		
VRB-42-24W-BLK-WF-35K		
SIZE	DWG. NO.	REV
<b>A</b>		
SCALE: 1:3.5WEIGHT:		SHEET 11 OF 13

ITEM NO.	PART NUMBER	DESCRIPTION	QTY.
1	VRB-42-24W-BLK-WF-35K-TUBE SLEEVE	SPUN ALUMINUM 0.080"	1

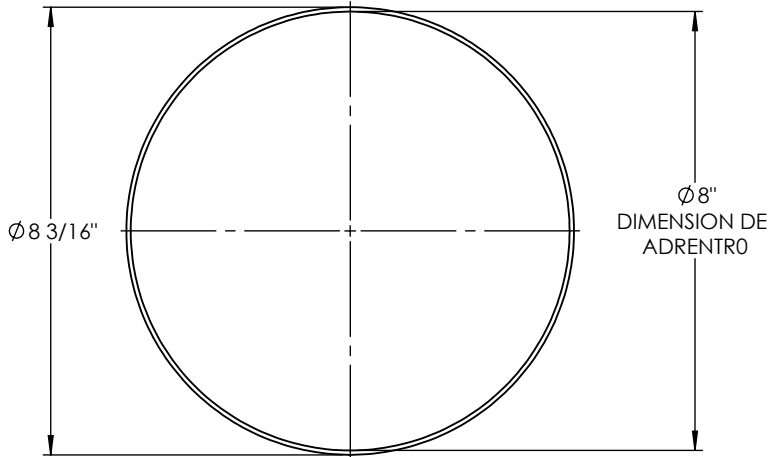
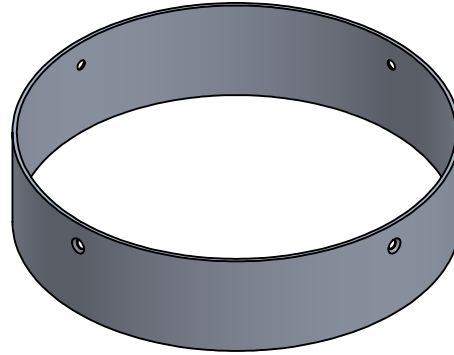
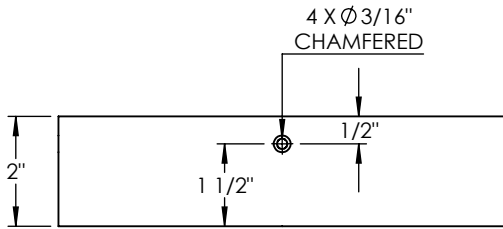

UNLESS OTHERWISE SPECIFIED:  DIMENSIONS ARE IN INCHES TOLERANCES: FRACTIONAL $\pm$ ANGULAR: MACH $\pm$ BEND $\pm$ TWO PLACE DECIMAL $\pm$ THREE PLACE DECIMAL $\pm$		NAME	DATE	<b>SPUN ALUMINUM 0.080"</b>  TITLE:  <b>VRB-42-24W-BLK-WF-35K</b>		
		DRAWN				
		CHECKED				
		ENG APPR.				
		MFG APPR.				
	Q.A.					
	COMMENTS:					
	INTERPRET GEOMETRIC TOLERANCING PER:			SIZE	DWG. NO.	REV
	MATERIAL			<b>A</b>		
	FINISH			SCALE: 1:3.5		WEIGHT:
	DO NOT SCALE DRAWING					SHEET 12 OF 13

**PROPRIETARY AND CONFIDENTIAL**  
 THE INFORMATION CONTAINED IN THIS DRAWING IS THE SOLE PROPERTY OF <INSERT COMPANY NAME HERE>. ANY REPRODUCTION IN PART OR AS A WHOLE WITHOUT THE WRITTEN PERMISSION OF <INSERT COMPANY NAME HERE> IS PROHIBITED.

NEXT ASSY	USED ON
APPLICATION	

$\Phi 7 \frac{11}{16}$ "

$\Phi 5$ "

$3 \frac{9}{16}$ "

$3 \frac{9}{16}$ "

$\Phi 3$ "

$\Phi 5/8$ "

**(4) 1/2" X 16" LONG  
ANCHOR BOLT SIZE**

