

UNLESS OTHERWISE SPECIFIED:

DIMENSIONS ARE IN INCHES
 TOLERANCES:
 FRACTIONAL ± .003
 ANGULAR: MACH ± .01 BEND ±
 TWO PLACE DECIMAL ±
 THREE PLACE DECIMAL ±.001

INTERPRET GEOMETRIC
 TOLERANCING PER:

MATERIAL

FINISH

ALL BEND RADIUS .030"

APPLICATION

DO NOT SCALE DRAWING

| | NAME | DATE |
|-----------|------|------|
| DRAWN | R.N. | |
| CHECKED | | |
| ENG APPR. | | |
| MFG APPR. | | |
| Q.A. | | |

COMMENTS:

TITLE:

POM4324L-MBK-A-40K

| SIZE | DWG. NO. | REV |
|------------|--------------|--------------|
| A | TICKET 26061 | |
| SCALE: 1:8 | WEIGHT: | SHEET 1 OF 9 |



EVERGREEN LIGHTING

5

4

3

2

1

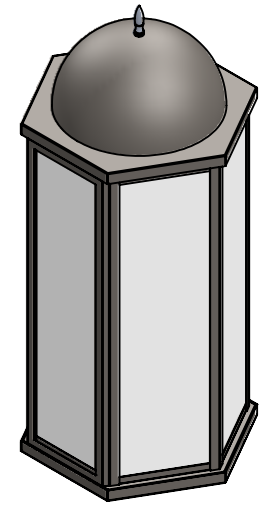
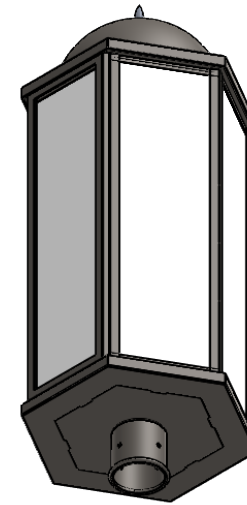
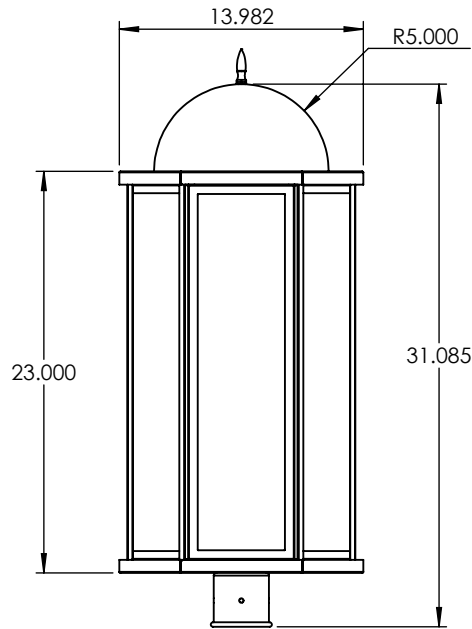
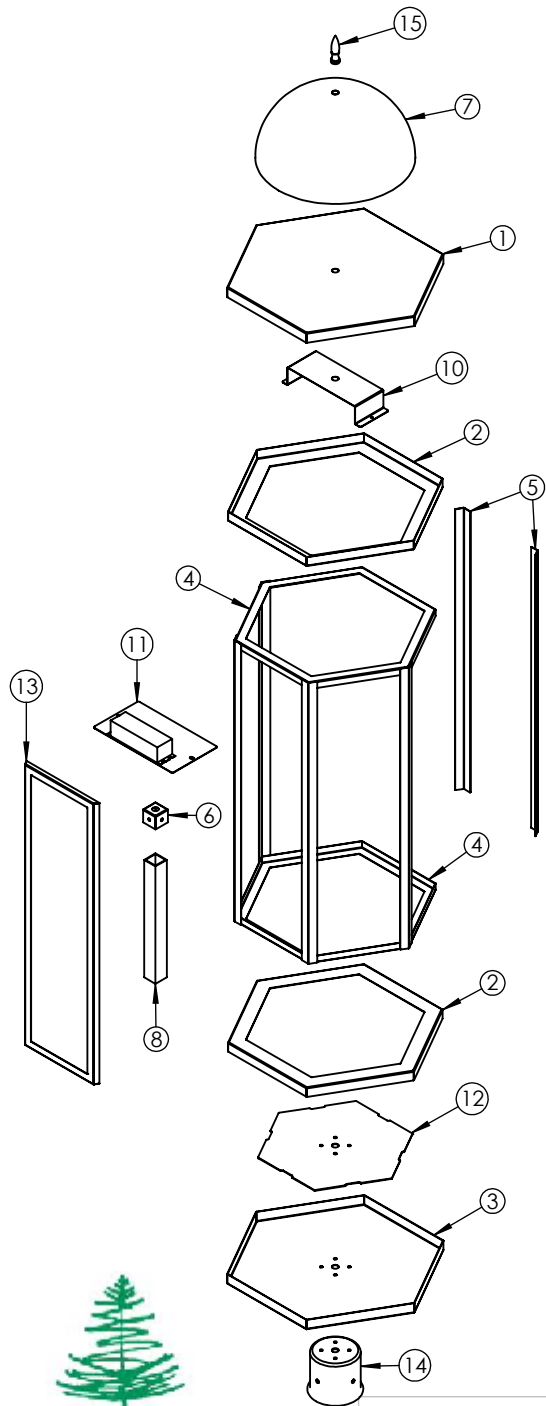

| ITEM NO. | PART NUMBER | DESCRIPTION | QTY. | CUT |
|----------|--------------------------------------|-------------------------|------|-----|
| 1 | POM4324L-MBK-A-40K-TOP FRAME | 22 GAUGE | 1 | CUT |
| 2 | POM4324L-MBK-A-40K-INNER FRAME COVER | 22 GAUGE | 2 | |
| 3 | POM4324L-MBK-A-40K-BOTTOM FRAME | 22 GAUGE | 1 | |
| 4 | POM4324L-MBK-A-40K-BODY FRAME | 22 GAUGE | 2 | |
| 5 | POM4324L-MBK-A-40K-VERTICAL RIB | 22 GAUGE | 6 | |
| 6 | POM4324L-MBK-A-40K-TUBE BRACKET | 22 GAUGE | 1 | |
| 7 | POM4324L-MBK-A-40K-SPUN SPHERE | SPUN 22 GAUGE | 1 | |
| 8 | POM4324L-MBK-A-40K-SQUARE TUBE | 1" SQUARE ALUMINUM TUBE | 1 | |
| 10 | POM4324L-MBK-A-40K-REFLECTOR BRACKET | 22 GAUGE | 1 | |
| 11 | POM4324L-MBK-A-40K-REFLECTOR PLATE | 22 GAUGE | 1 | |
| 12 | POM4324L-MBK-A-40K-BOTTOM PLATE | 18 GAUGE | 1 | |
| 13 | POM4324L-MBK-A-40K-FRAME DOOR | 22 GAUGE | 1 | |
| 14 | POST FITTER | 3" STEEL POST FITTER | 1 | |
| 15 | BULLET ACCENT | BRASS ACCENT | 1 | |
| 16 | SMALL NUT | STEEL NUT | 1 | |
| 17 | ESPEN VEL29070MVH-1 | DRIVER | 1 | |
| 18 | NIPPLE | NIPPLE | 1 | |
| 19 | AltILED_PN1010_RevD | LED | 4 | |

UNLESS OTHERWISE SPECIFIED:

DIMENSIONS ARE IN INCHES
 TOLERANCES:
 FRACTIONAL ± .003
 ANGULAR: MACH ± .01 BEND ±
 TWO PLACE DECIMAL ±
 THREE PLACE DECIMAL ±.001

INTERPRET GEOMETRIC
 TOLERANCING PER:

MATERIAL

FINISH

| | NAME | DATE |
|-----------|------|------|
| DRAWN | R.N. | |
| CHECKED | | |
| ENG APPR. | | |
| MFG APPR. | | |
| Q.A. | | |

COMMENTS:

TITLE:

POM4324L-MBK-A-40K

| SIZE | DWG. NO. | REV |
|----------|--------------|-----|
| A | TICKET 26061 | |

SCALE: 1:11 WEIGHT: SHEET 2 OF 9

EVERGREEN LIGHTING

ALL BEND RADIUS .030"

APPLICATION

DO NOT SCALE DRAWING

5

4

3

2

1

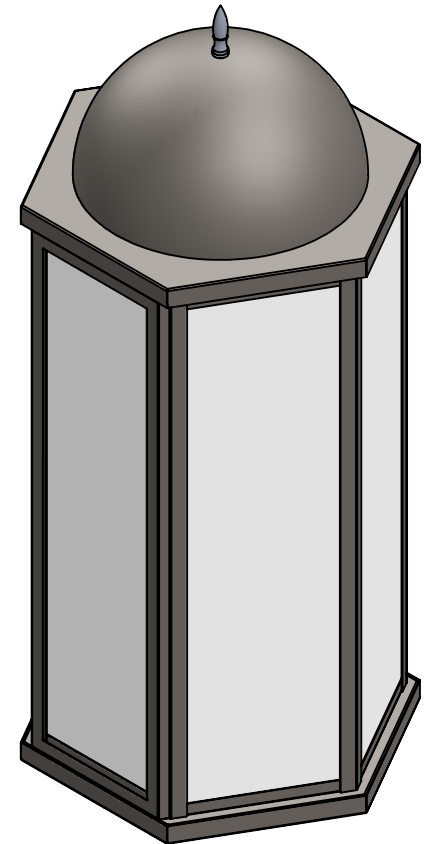
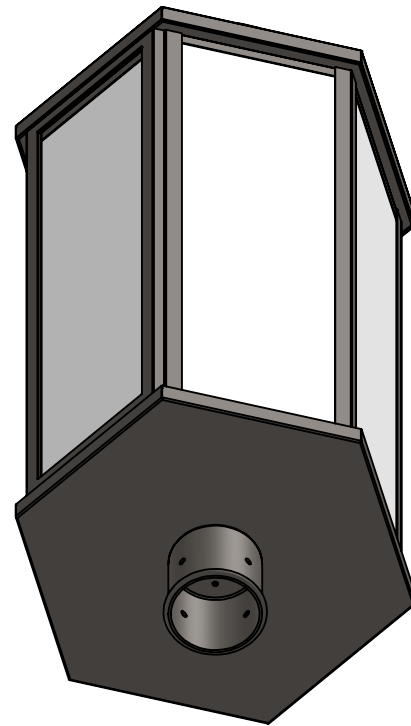
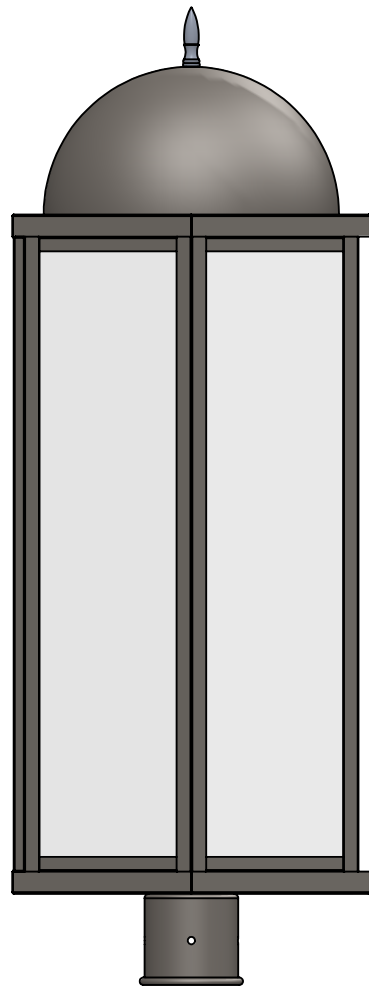
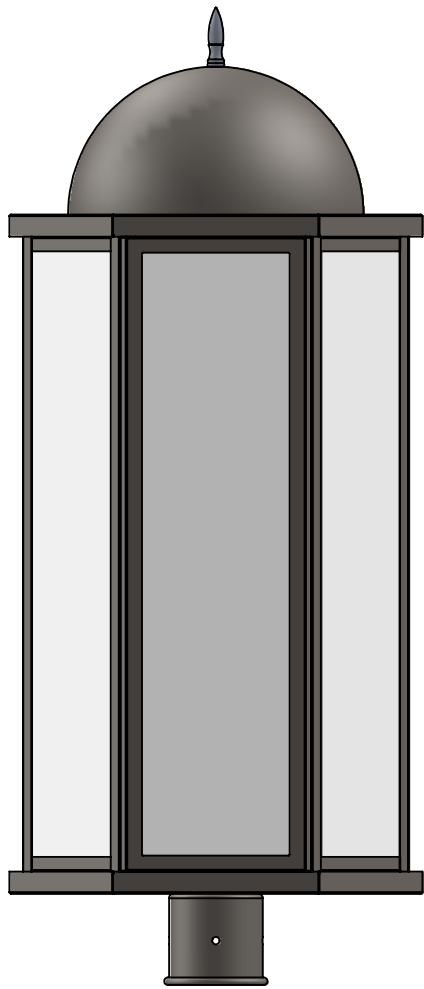

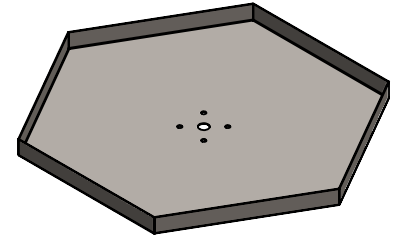
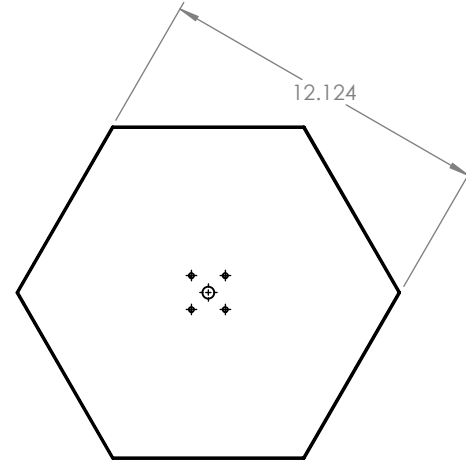
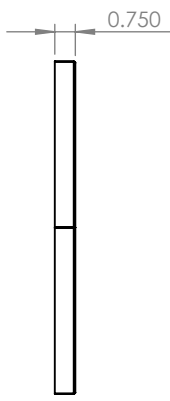
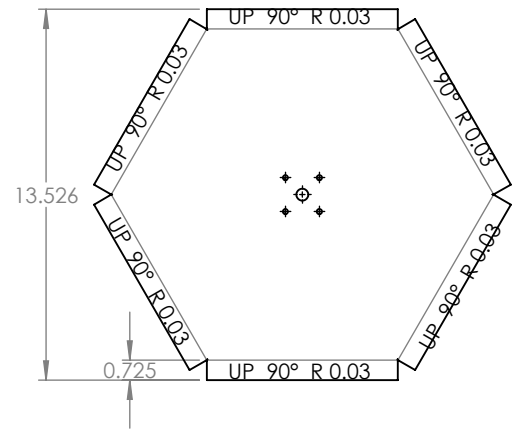
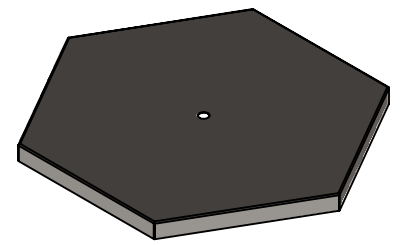
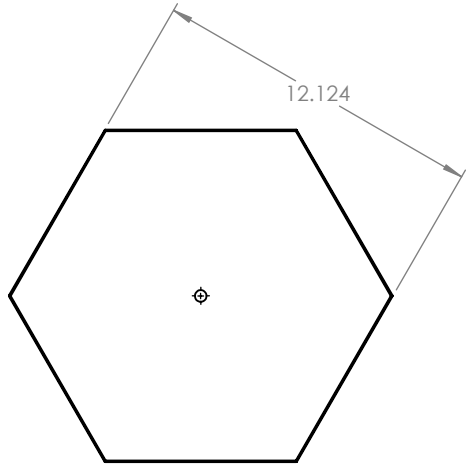
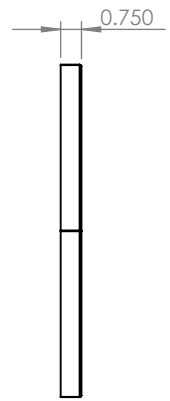
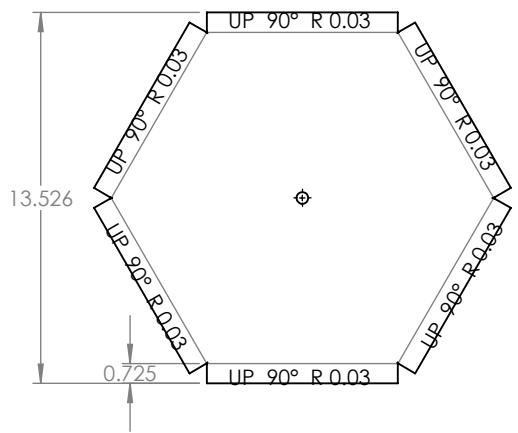

PROPRIETARY AND CONFIDENTIAL
 THE INFORMATION CONTAINED IN THIS DRAWING IS THE SOLE PROPERTY OF <INSERT COMPANY NAME HERE>. ANY REPRODUCTION IN PART OR AS A WHOLE WITHOUT THE WRITTEN PERMISSION OF <INSERT COMPANY NAME HERE> IS PROHIBITED.

| | |
|-------------|---------|
| NEXT ASSY | USED ON |
| APPLICATION | |

| |
|--------------------------------------|
| UNLESS OTHERWISE SPECIFIED: |
| DIMENSIONS ARE IN INCHES |
| TOLERANCES: |
| FRACTIONAL ± |
| ANGULAR: MACH ± BEND ± |
| TWO PLACE DECIMAL ± |
| THREE PLACE DECIMAL ± |
| INTERPRET GEOMETRIC TOLERANCING PER: |
| MATERIAL |
| FINISH |
| DO NOT SCALE DRAWING |

| NAME | DATE |
|-----------|------|
| DRAWN | |
| CHECKED | |
| ENG APPR. | |
| MFG APPR. | |
| Q.A. | |
| COMMENTS: | |

| | | |
|--------------------|----------|--------------|
| 22 GAUGE | | |
| TITLE: | | |
| POM4324L-MBK-A-40K | | |
| SIZE | DWG. NO. | REV |
| A | | |
| SCALE: 1:7 | WEIGHT: | SHEET 4 OF 9 |

5

4

3

2

1

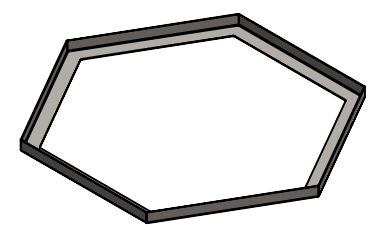
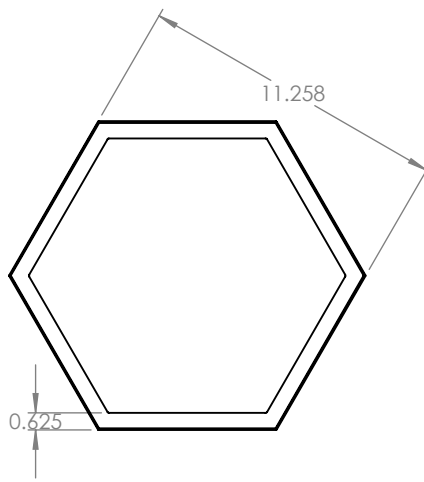
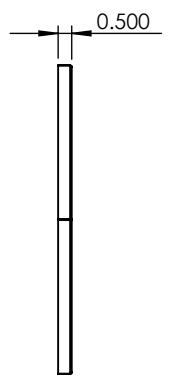
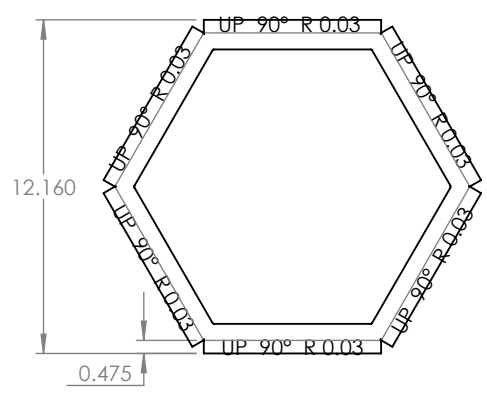
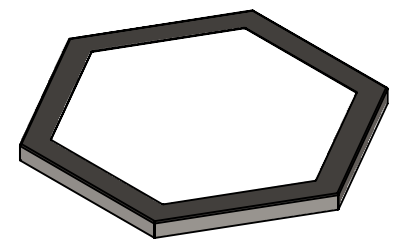
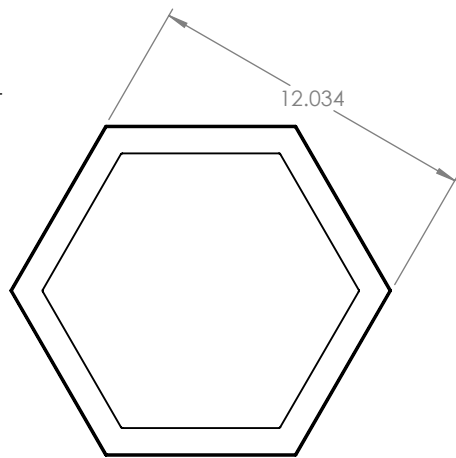
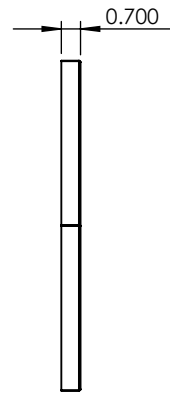
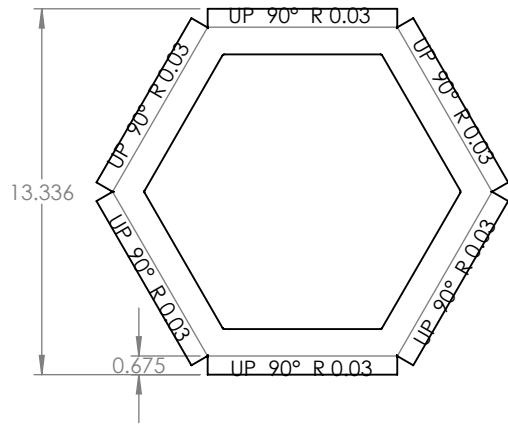

PROPRIETARY AND CONFIDENTIAL
 THE INFORMATION CONTAINED IN THIS DRAWING IS THE SOLE PROPERTY OF <INSERT COMPANY NAME HERE>. ANY REPRODUCTION IN PART OR AS A WHOLE WITHOUT THE WRITTEN PERMISSION OF <INSERT COMPANY NAME HERE> IS PROHIBITED.

| | |
|-------------|---------|
| NEXT ASSY | USED ON |
| APPLICATION | |

UNLESS OTHERWISE SPECIFIED:
 DIMENSIONS ARE IN INCHES
 TOLERANCES:
 FRACTIONAL ±
 ANGULAR: MACH ± BEND ±
 TWO PLACE DECIMAL ±
 THREE PLACE DECIMAL ±
 INTERPRET GEOMETRIC TOLERANCING PER:
 MATERIAL
 FINISH
 DO NOT SCALE DRAWING

| | NAME | DATE |
|-----------|------|------|
| DRAWN | | |
| CHECKED | | |
| ENG APPR. | | |
| MFG APPR. | | |
| Q.A. | | |
| COMMENTS: | | |

| | | |
|------------------------------|----------|--------------|
| 22 GAUGE | | |
| TITLE: POM4324L-MBK-A-40K | | |
| SIZE A | DWG. NO. | REV |
| SCALE: 1:7 | WEIGHT: | SHEET 5 OF 9 |

5

4

3

2

1

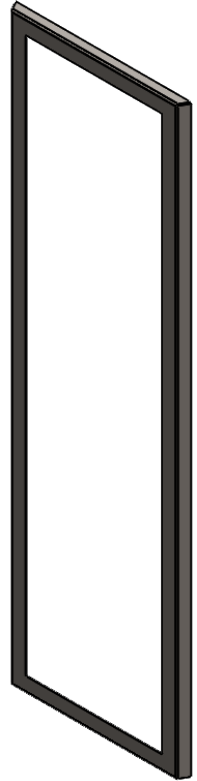
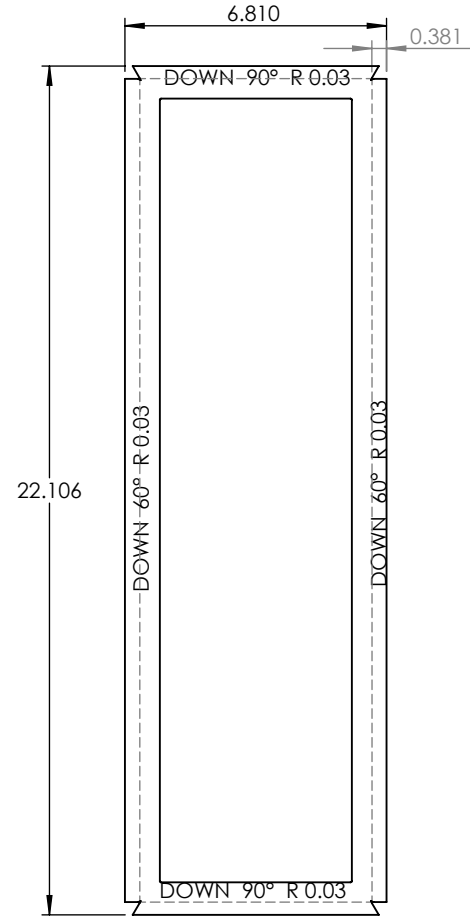
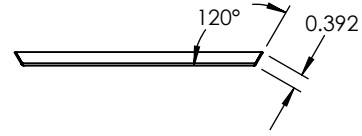
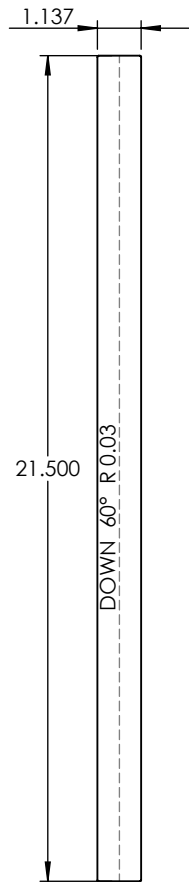
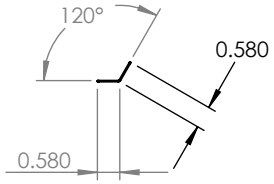

PROPRIETARY AND CONFIDENTIAL
 THE INFORMATION CONTAINED IN THIS DRAWING IS THE SOLE PROPERTY OF <INSERT COMPANY NAME HERE>. ANY REPRODUCTION IN PART OR AS A WHOLE WITHOUT THE WRITTEN PERMISSION OF <INSERT COMPANY NAME HERE> IS PROHIBITED.

| | | |
|-------------|---------|--------------------------------------|
| | | INTERPRET GEOMETRIC TOLERANCING PER: |
| | | MATERIAL |
| NEXT ASSY | USED ON | FINISH |
| APPLICATION | | DO NOT SCALE DRAWING |

UNLESS OTHERWISE SPECIFIED:
 DIMENSIONS ARE IN INCHES
 TOLERANCES:
 FRACTIONAL ±
 ANGULAR: MACH ± BEND ±
 TWO PLACE DECIMAL ±
 THREE PLACE DECIMAL ±

| | NAME | DATE |
|-----------|------|------|
| DRAWN | | |
| CHECKED | | |
| ENG APPR. | | |
| MFG APPR. | | |

| | | |
|-------------------------------------|----------|--------------|
| 22 GAUGE | | |
| TITLE: POM4324L-MBK-A-40K | | |
| SIZE A | DWG. NO. | REV |
| SCALE: 1:5 | WEIGHT: | SHEET 6 OF 9 |

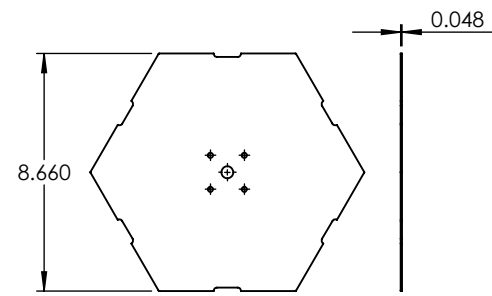
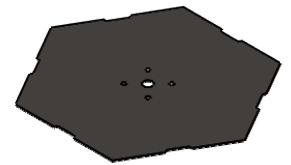
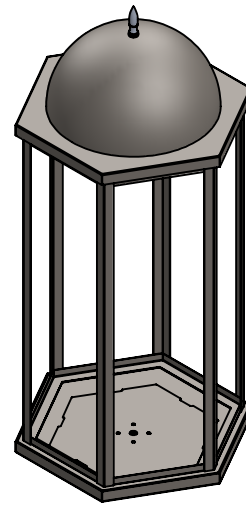
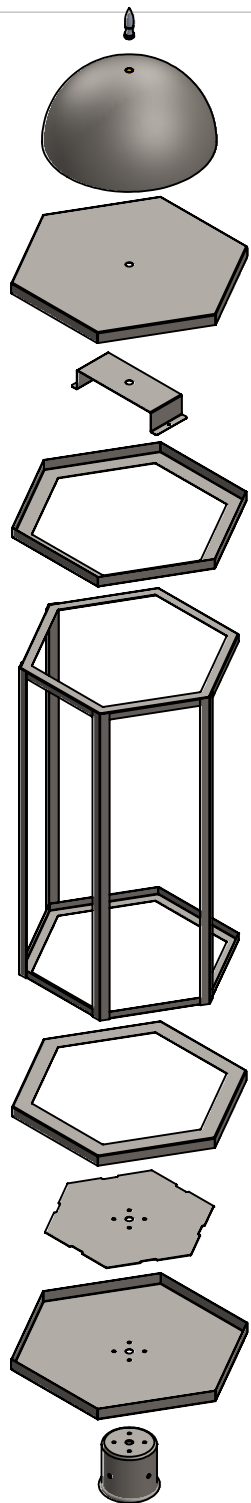

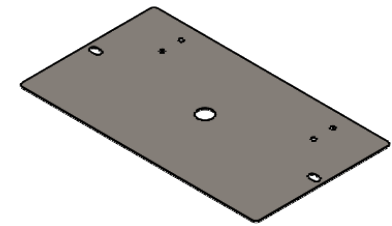
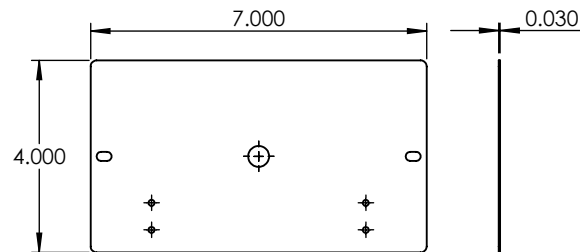
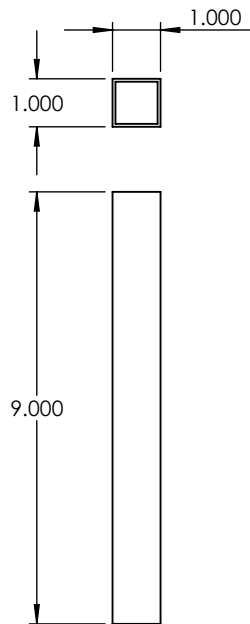
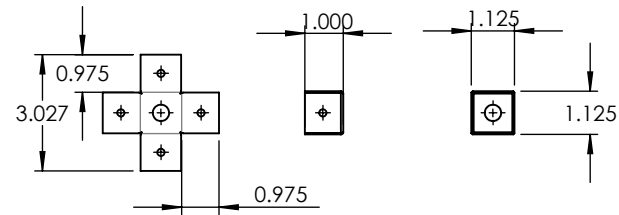
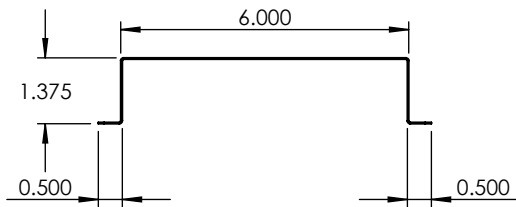
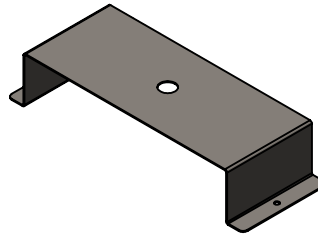
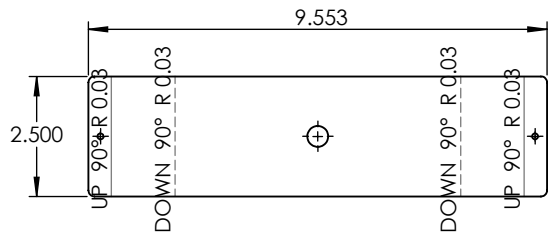

PROPRIETARY AND CONFIDENTIAL
 THE INFORMATION CONTAINED IN THIS DRAWING IS THE SOLE PROPERTY OF <INSERT COMPANY NAME HERE>. ANY REPRODUCTION IN PART OR AS A WHOLE WITHOUT THE WRITTEN PERMISSION OF <INSERT COMPANY NAME HERE> IS PROHIBITED.

| | | | | | | |
|-------------|---------|--------------------------------------|-----------|------|----------------------------------|--------------|
| | | UNLESS OTHERWISE SPECIFIED: | NAME | DATE | 22 GAUGE | |
| | | DIMENSIONS ARE IN INCHES | DRAWN | | TITLE: POM4324L-MBK-A-40K | |
| | | TOLERANCES: | CHECKED | | | |
| | | FRACTIONAL ± | ENG APPR. | | | |
| | | ANGULAR: MACH ± BEND ± | MFG APPR. | | | |
| | | TWO PLACE DECIMAL ± | Q.A. | | SIZE | DWG. NO. |
| | | THREE PLACE DECIMAL ± | COMMENTS: | | A | REV |
| | | INTERPRET GEOMETRIC TOLERANCING PER: | | | SCALE: 1:4 | WEIGHT: |
| | | MATERIAL | | | | SHEET 8 OF 9 |
| | | FINISH | | | | |
| NEXT ASSY | USED ON | DO NOT SCALE DRAWING | | | | |
| APPLICATION | | | | | | |

5

4

3

2

1

| ITEM NO. | PART NUMBER | DESCRIPTION | QTY. |
|----------|--------------------------------|---------------|------|
| 1 | POM4324L-MBK-A-40K-SPUN SPHERE | SPUN 22 GAUGE | 1 |

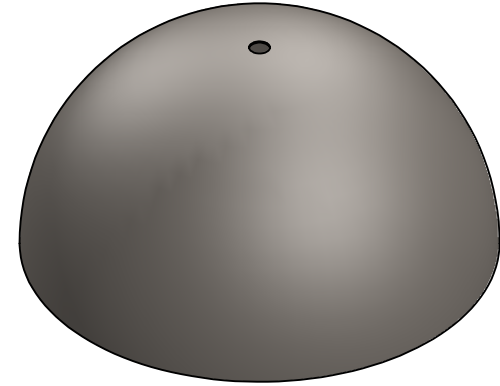
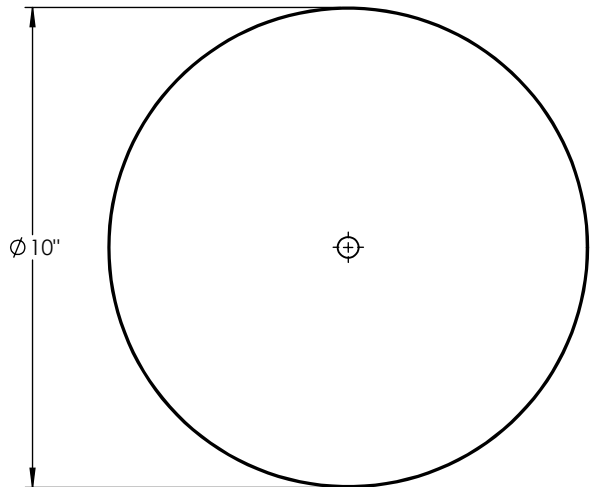
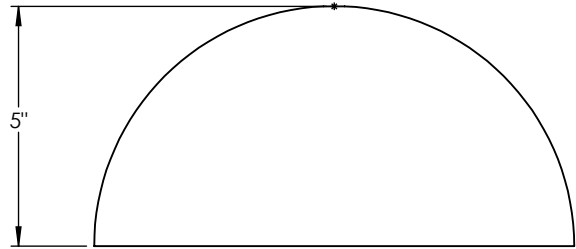

| | | | | | | |
|--|----------------------|------|------|---------------|----------|--------------|
| UNLESS OTHERWISE SPECIFIED: DIMENSIONS ARE IN INCHES TOLERANCES: FRACTIONAL ± ANGULAR: MACH ± BEND ± TWO PLACE DECIMAL ± THREE PLACE DECIMAL ± | | NAME | DATE | SPUN 22 GAUGE | | |
| | DRAWN | | | | | |
| | CHECKED | | | | | |
| | ENG APPR. | | | | | |
| | MFG APPR. | | | | | |
| INTERPRET GEOMETRIC TOLERANCING PER: | Q.A. | | | SIZE | DWG. NO. | REV |
| MATERIAL | COMMENTS: | | | A | | |
| FINISH | | | | | | |
| APPLICATION | DO NOT SCALE DRAWING | | | SCALE: 1:4 | WEIGHT: | SHEET 9 OF 9 |

PROPRIETARY AND CONFIDENTIAL
THE INFORMATION CONTAINED IN THIS DRAWING IS THE SOLE PROPERTY OF <INSERT COMPANY NAME HERE>. ANY REPRODUCTION IN PART OR AS A WHOLE WITHOUT THE WRITTEN PERMISSION OF <INSERT COMPANY NAME HERE> IS PROHIBITED.

| | |
|-------------|---------|
| | |
| NEXT ASSY | USED ON |
| APPLICATION | |

5

4

3

2

1