

ITEM NO.	PART NUMBER	DESCRIPTION	QTY.	CUT
1	OPSQVAN-36"-30L-MN-WF-DIM-35K-FRONT PLATE	ALUMINUM 0.250" PLATE	1	
2	OPSQVAN-36"-30L-MN-WF-DIM-35K-ENDPLATE	ALUMINUM 0.250" PLATE	2	
3	OPSQVAN-36"-30L-MN-WF-DIM-35K-FRAME	ALUMINUM 0.0635"	1	
4	OPSQVAN-36"-30L-MN-WF-DIM-35K-BACPLATE	ALUMINUM 0.0635"	1	
5	OPSQVAN-36"-30L-MN-WF-DIM-35K-LED PLATE	ALUMINUM 0.0635"	1	
6	OPSQVAN-36"-30L-MN-WF-DIM-35K-DRIVER BRACKET	ALUMINUM 0.0635"	1	
7	OPSQVAN-36"-30L-MN-WF-DIM-35K-FIREPLATE	ALUMINUM 0.0635"	1	
8	OPSQVAN-36"-30L-MN-WF-DIM-35K-ACRYLIC	ACRYLIC	1	
9	KTLD-25-UV-700-VDIM-LA1	DRIVER	1	
10	DS-15W-350C1542010-3001	DRIVER	1	
11	AltalLED_PN110B_RevC	LED	3	

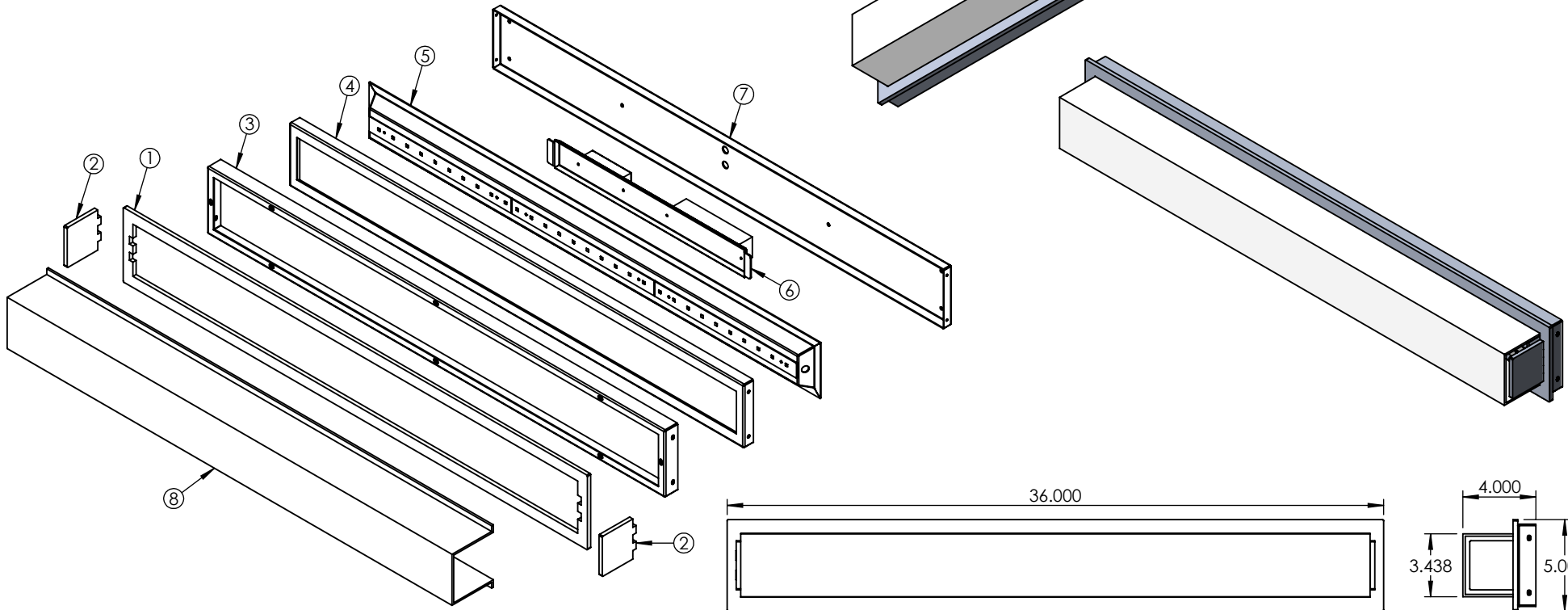

UNLESS OTHERWISE SPECIFIED:		NAME	DATE	TITLE:	
DIMENSIONS ARE IN INCHES		DRAWN		OPSQVAN-36"-30L-MN-WF-DIM-35K	
TOLERANCES:		CHECKED			
FRACTIONAL ± .003		ENG APPR.			
ANGULAR: MACH ± .01 BEND ±		MFG APPR.			
TWO PLACE DECIMAL ±		Q.A.		SIZE DWG. NO. REV	
THREE PLACE DECIMAL ±.001		COMMENTS:		<b>A</b> TICKET 26081	
INTERPRET GEOMETRIC TOLERANCING PER:				SCALE: 1:8.5WEIGHT: SHEET 1 OF 8	
MATERIAL					
FINISH					



ALL BEND RADIUS .030"

APPLICATION

DO NOT SCALE DRAWING

5

4

3

2

1

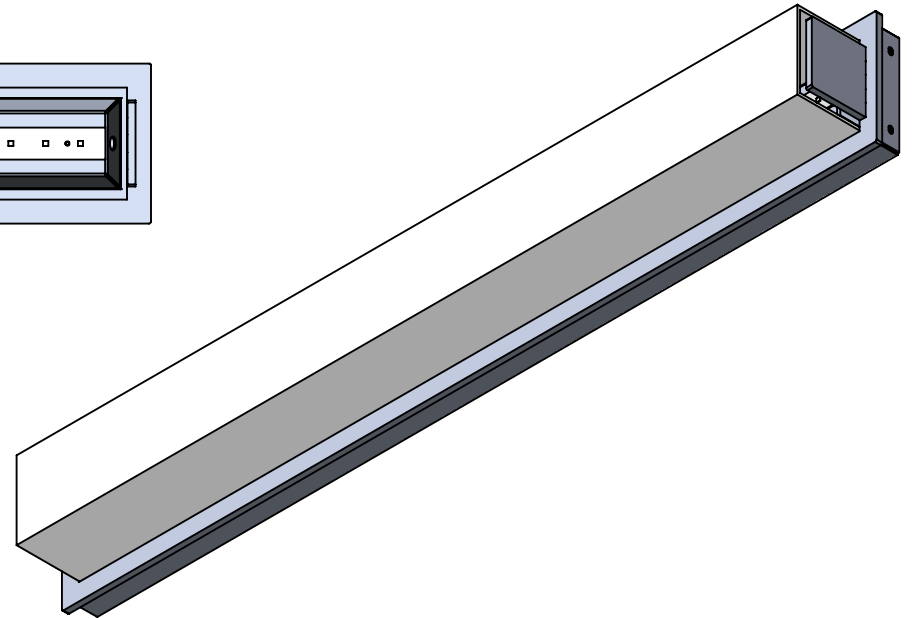
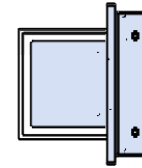
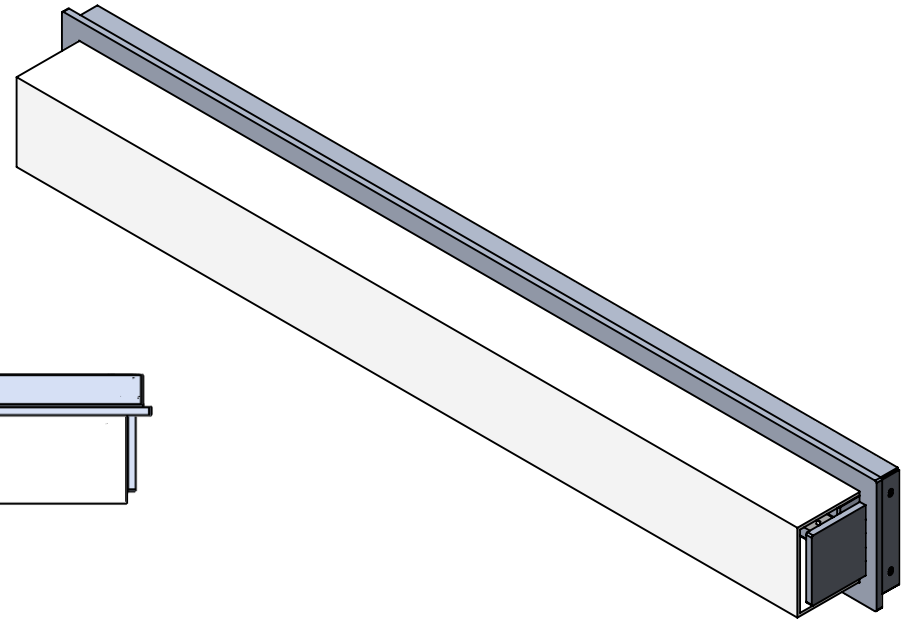
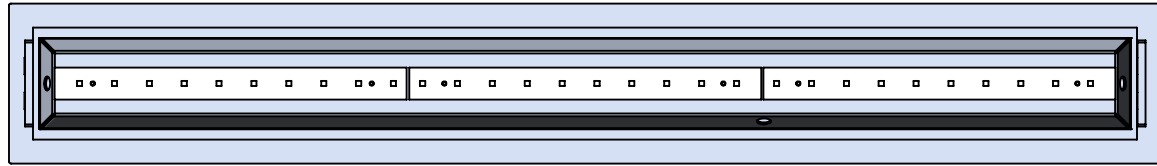
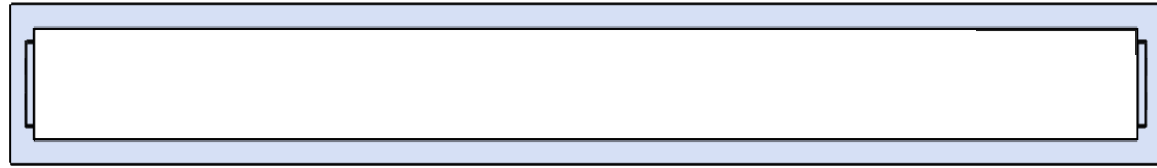
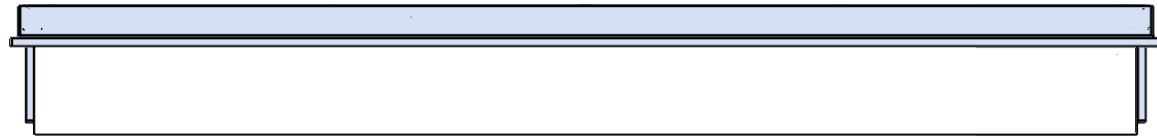

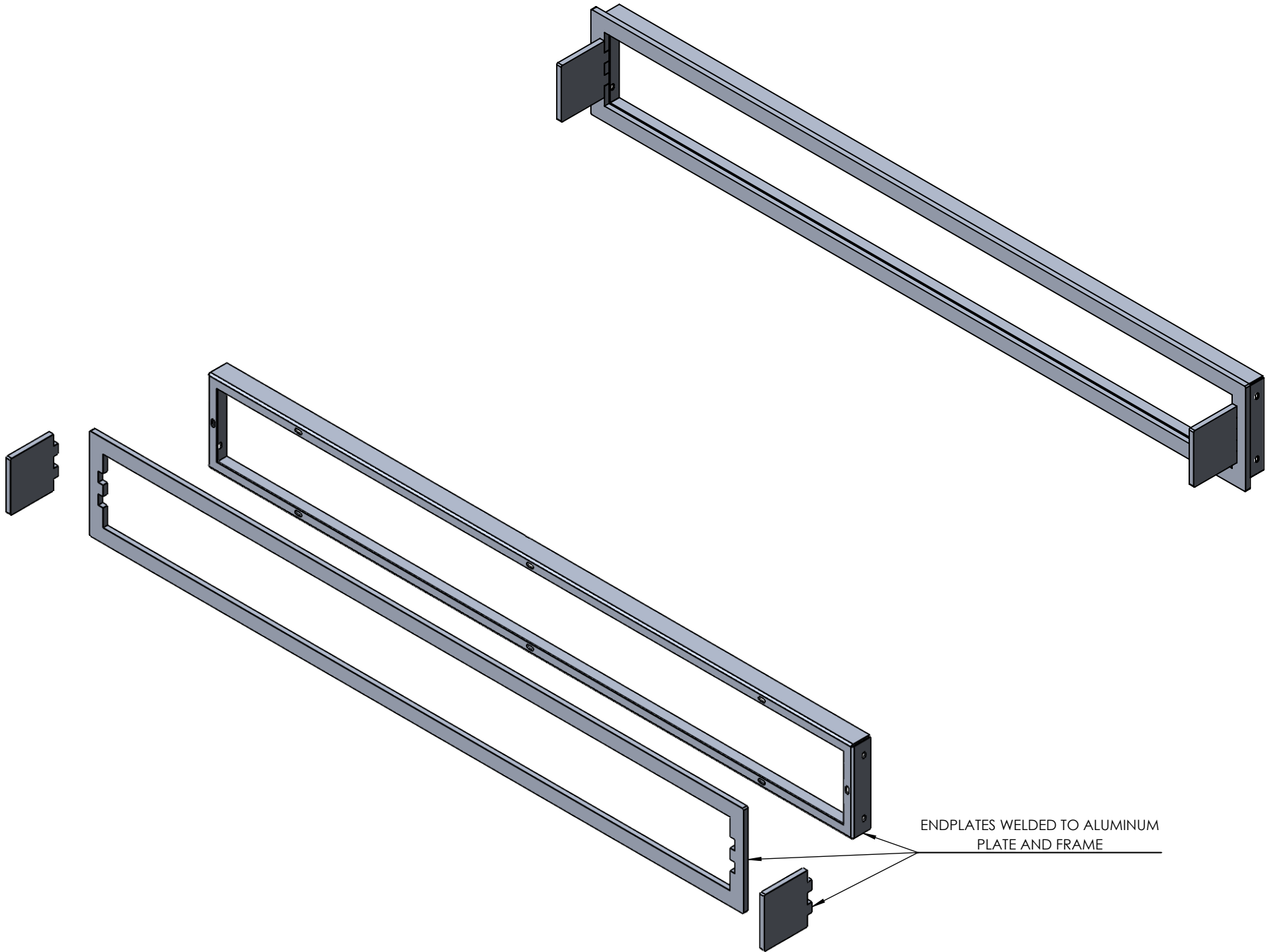

ENDPLATES WELDED TO ALUMINUM  
PLATE AND FRAME

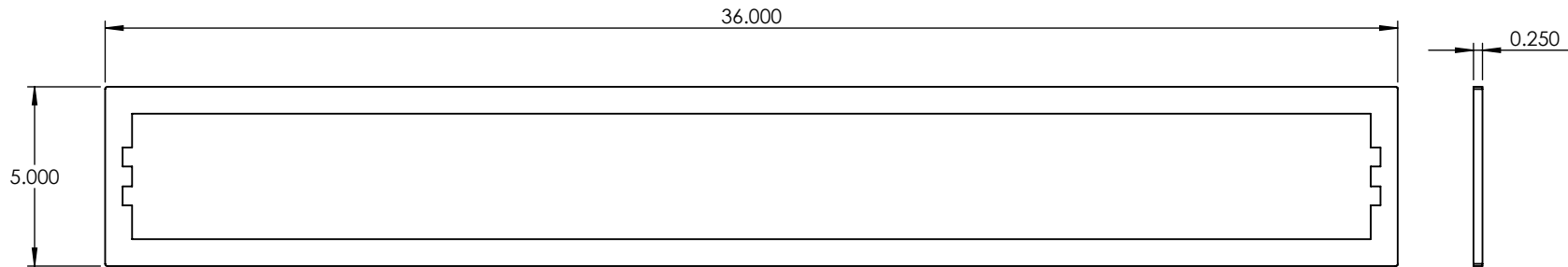
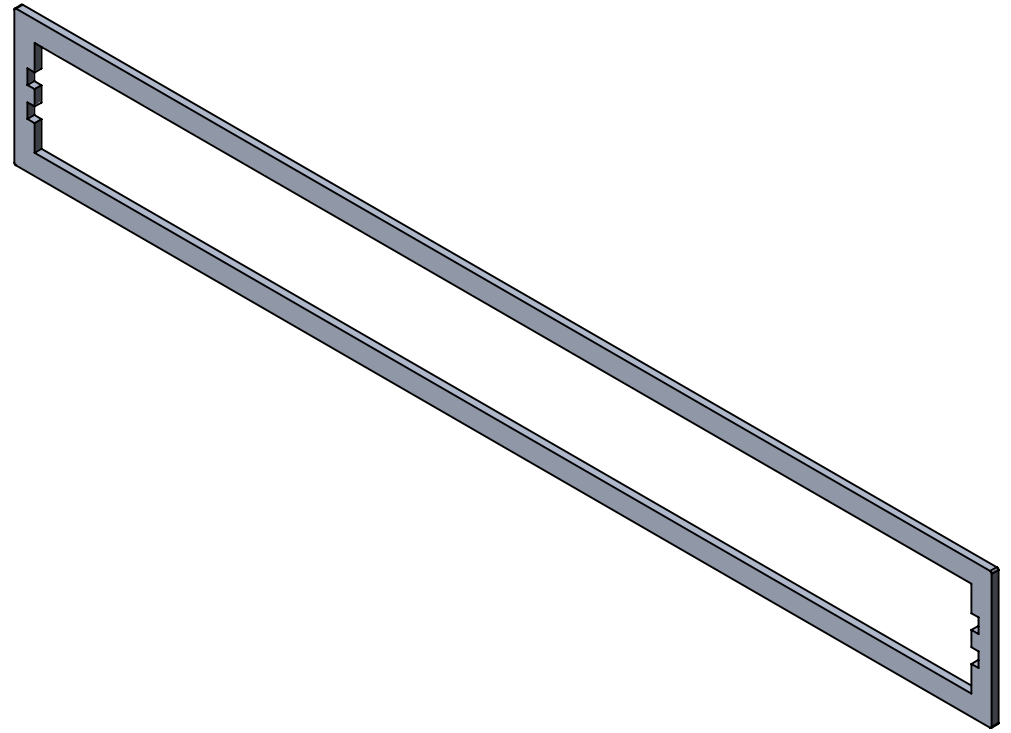
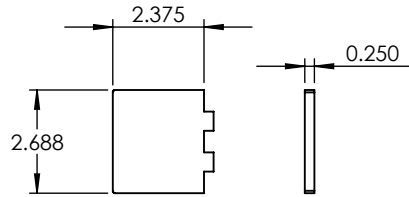

**PROPRIETARY AND CONFIDENTIAL**  
 THE INFORMATION CONTAINED IN THIS DRAWING IS THE SOLE PROPERTY OF <INSERT COMPANY NAME HERE>. ANY REPRODUCTION IN PART OR AS A WHOLE WITHOUT THE WRITTEN PERMISSION OF <INSERT COMPANY NAME HERE> IS PROHIBITED.

		UNLESS OTHERWISE SPECIFIED:		NAME	DATE
		DIMENSIONS ARE IN INCHES	DRAWN		
		TOLERANCES:	CHECKED		
		FRACTIONAL ±	ENG APPR.		
		ANGULAR: MACH ± BEND ±	MFG APPR.		
		TWO PLACE DECIMAL ±	Q.A.		
		THREE PLACE DECIMAL ±	COMMENTS:		
		INTERPRET GEOMETRIC TOLERANCING PER:			
		MATERIAL			
		FINISH			
NEXT ASSY	USED ON				
APPLICATION		DO NOT SCALE DRAWING			

ALUMINUM 0.250" PLATE

TITLE:  
 OPSQVAN-36"-30L-MN-WF-DIM-35K

SIZE	DWG. NO.	REV
<b>A</b>		

SCALE: 1:5	WEIGHT:	SHEET 4 OF 8
------------	---------	--------------

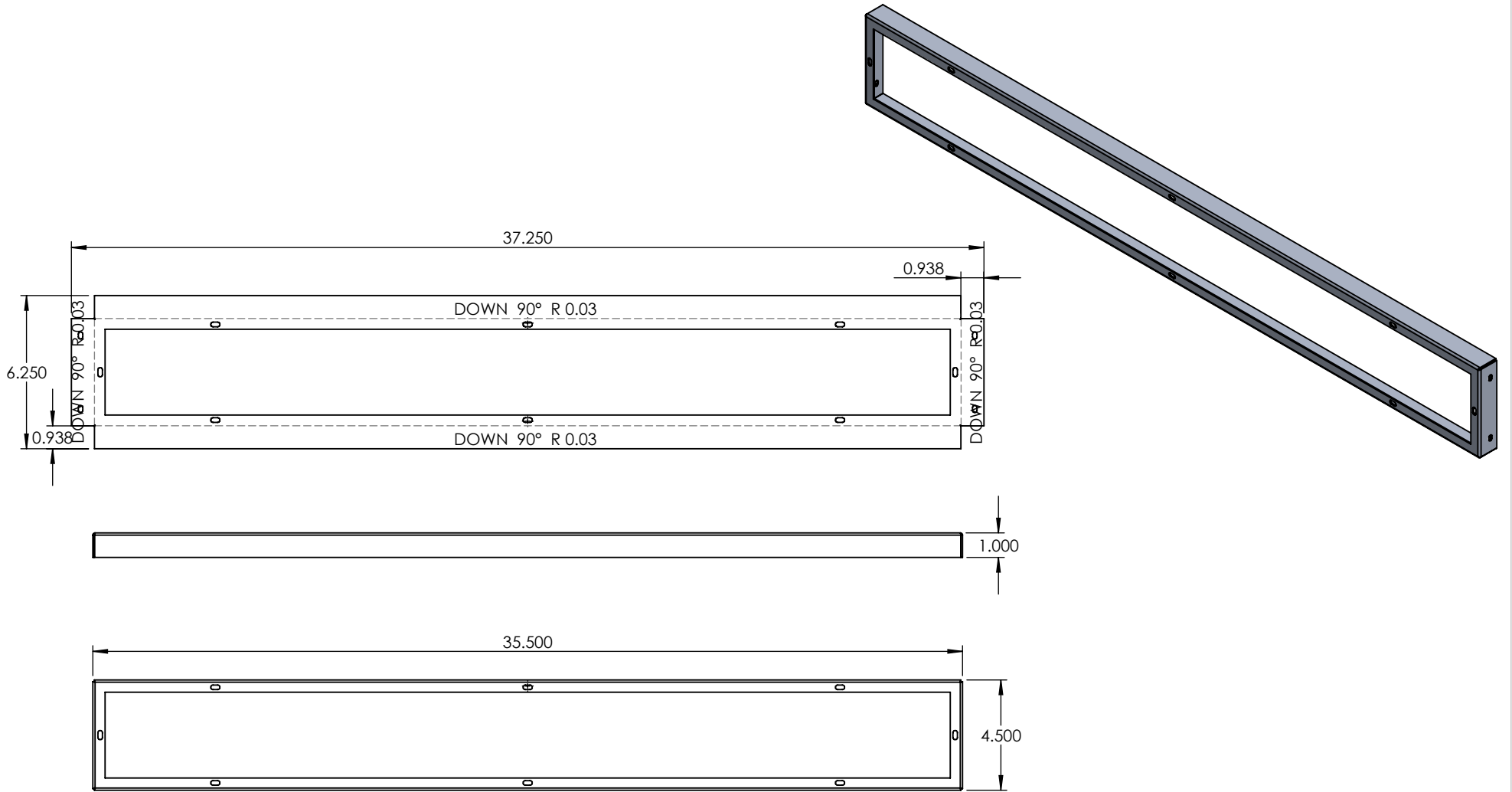

**PROPRIETARY AND CONFIDENTIAL**  
 THE INFORMATION CONTAINED IN THIS DRAWING IS THE SOLE PROPERTY OF <INSERT COMPANY NAME HERE>. ANY REPRODUCTION IN PART OR AS A WHOLE WITHOUT THE WRITTEN PERMISSION OF <INSERT COMPANY NAME HERE> IS PROHIBITED.

		UNLESS OTHERWISE SPECIFIED:		NAME	DATE	ALUMINUM 0.0635"	
		DIMENSIONS ARE IN INCHES	DRAWN			TITLE:	
		TOLERANCES:	CHECKED			OPSQVAN-36"-30L-MN-WF-DIM-35K	
		FRACTIONAL ±	ENG APPR.			SIZE DWG. NO. REV	
		ANGULAR: MACH ± BEND ±	MFG APPR.			A	
		TWO PLACE DECIMAL ±	Q.A.			SCALE: 1:6 WEIGHT: SHEET 5 OF 8	
		THREE PLACE DECIMAL ±	COMMENTS:				
		INTERPRET GEOMETRIC TOLERANCING PER:					
		MATERIAL					
	NEXT ASSY	USED ON					
		FINISH					
	APPLICATION	DO NOT SCALE DRAWING					

5

4

3

2

1

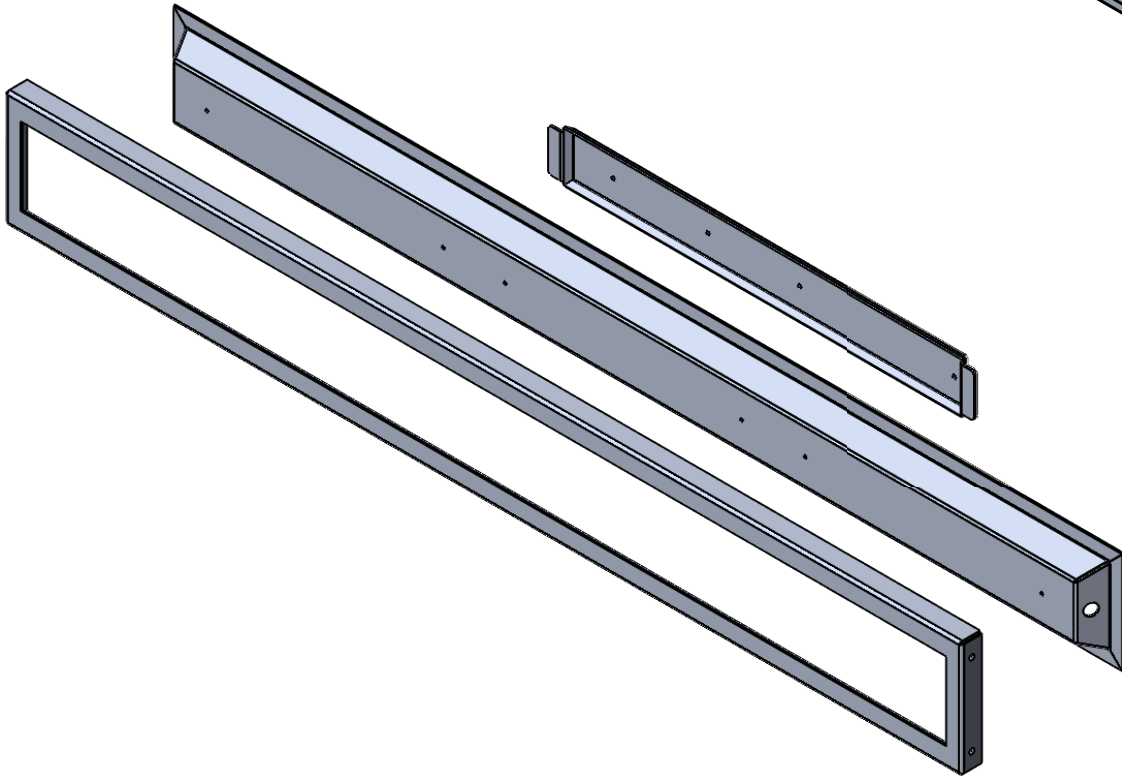
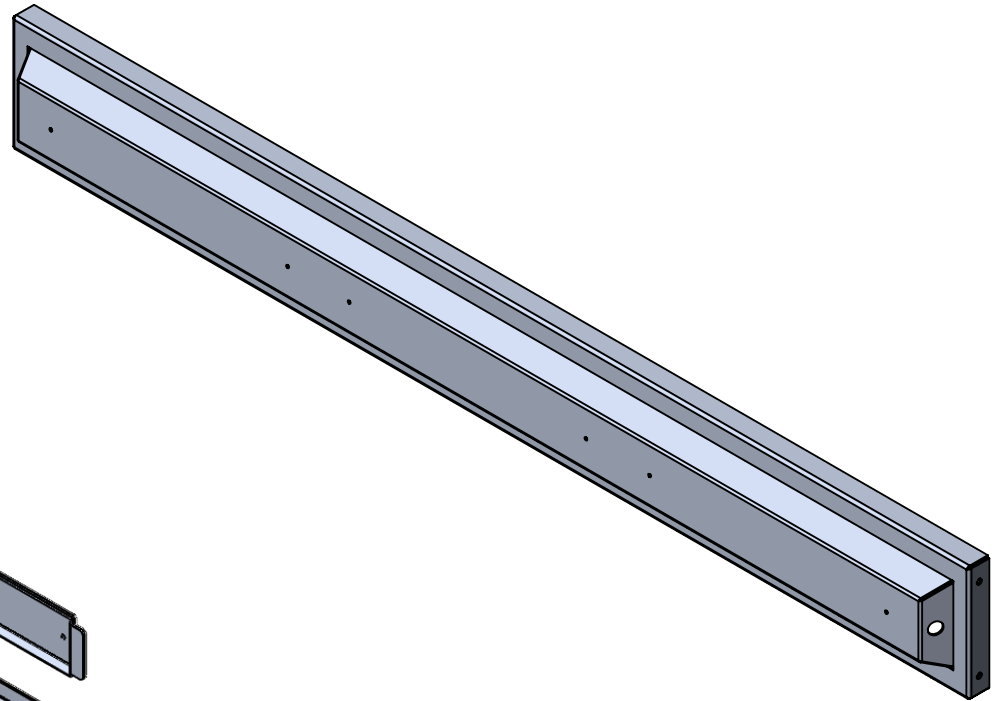
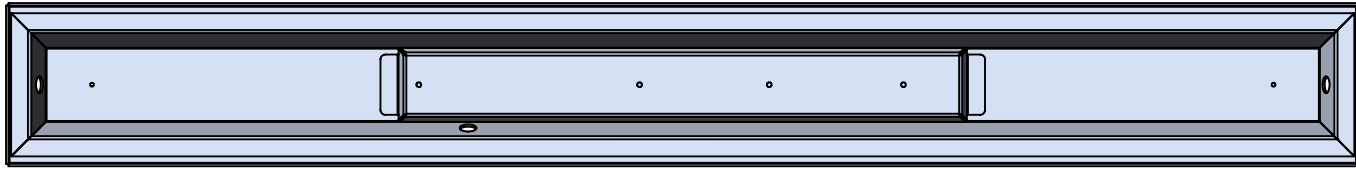

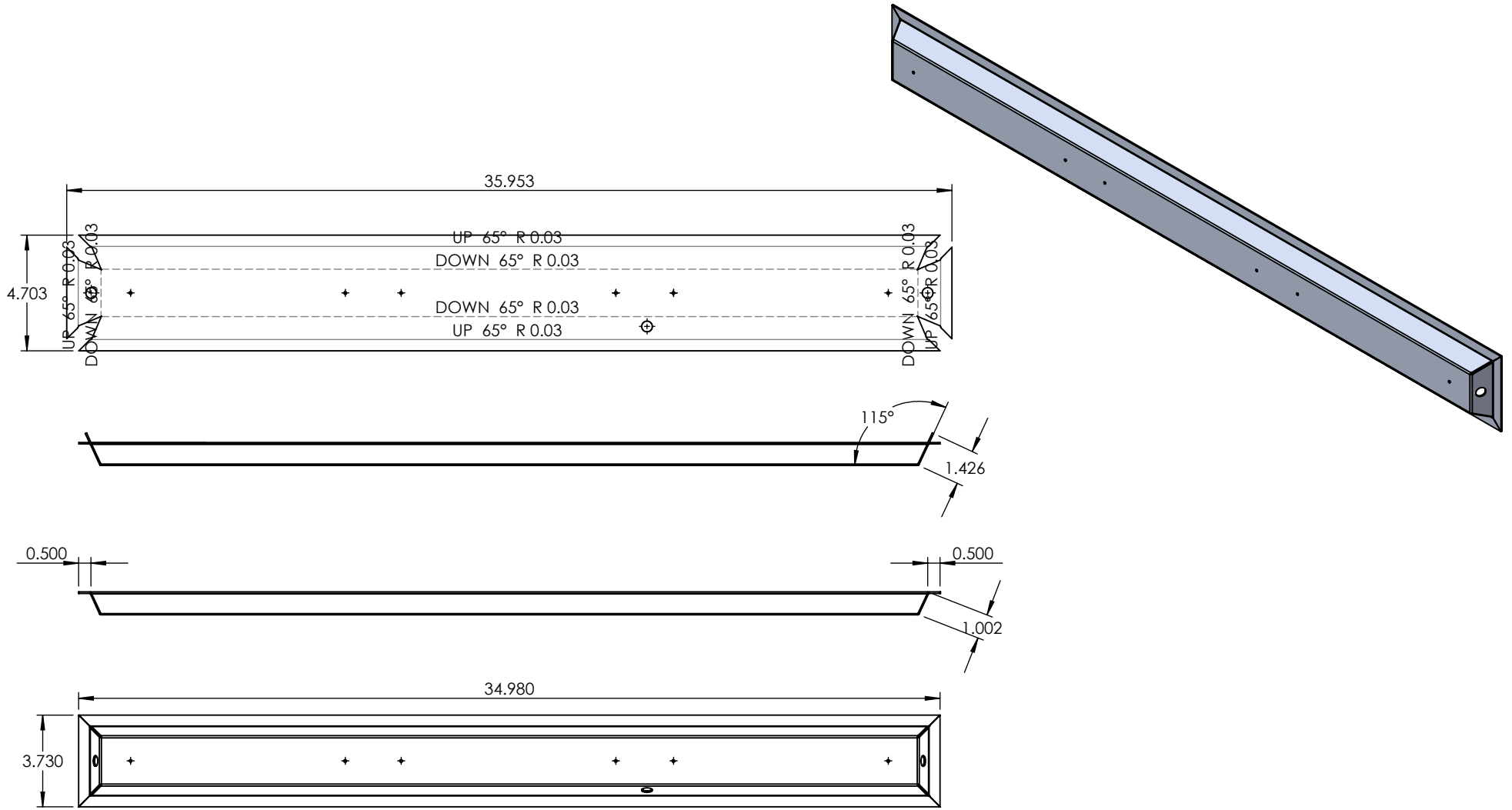

**PROPRIETARY AND CONFIDENTIAL**  
 THE INFORMATION CONTAINED IN THIS DRAWING IS THE SOLE PROPERTY OF <INSERT COMPANY NAME HERE>. ANY REPRODUCTION IN PART OR AS A WHOLE WITHOUT THE WRITTEN PERMISSION OF <INSERT COMPANY NAME HERE> IS PROHIBITED.

		UNLESS OTHERWISE SPECIFIED:	NAME	DATE
		DIMENSIONS ARE IN INCHES	DRAWN	
		TOLERANCES:	CHECKED	
		FRACTIONAL ±	ENG APPR.	
		ANGULAR: MACH ± BEND ±	MFG APPR.	
		TWO PLACE DECIMAL ±	Q.A.	
		THREE PLACE DECIMAL ±	COMMENTS:	
		INTERPRET GEOMETRIC TOLERANCING PER:		
		MATERIAL		
NEXT ASSY	USED ON	FINISH		
APPLICATION		DO NOT SCALE DRAWING		

ALUMINUM 0.0635"		
TITLE:		
OPSQVAN-36"-30L-MN-WF-DIM-35K		
SIZE	DWG. NO.	REV
<b>A</b>		
SCALE: 1:6	WEIGHT:	SHEET 7 OF 8

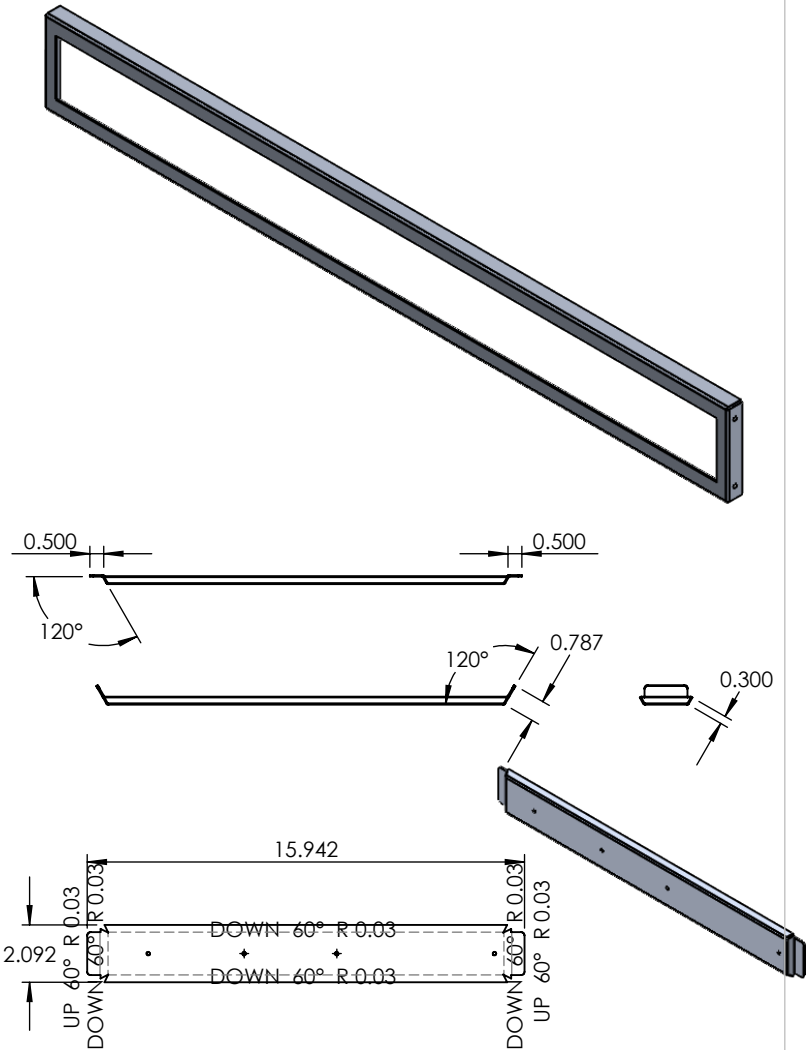
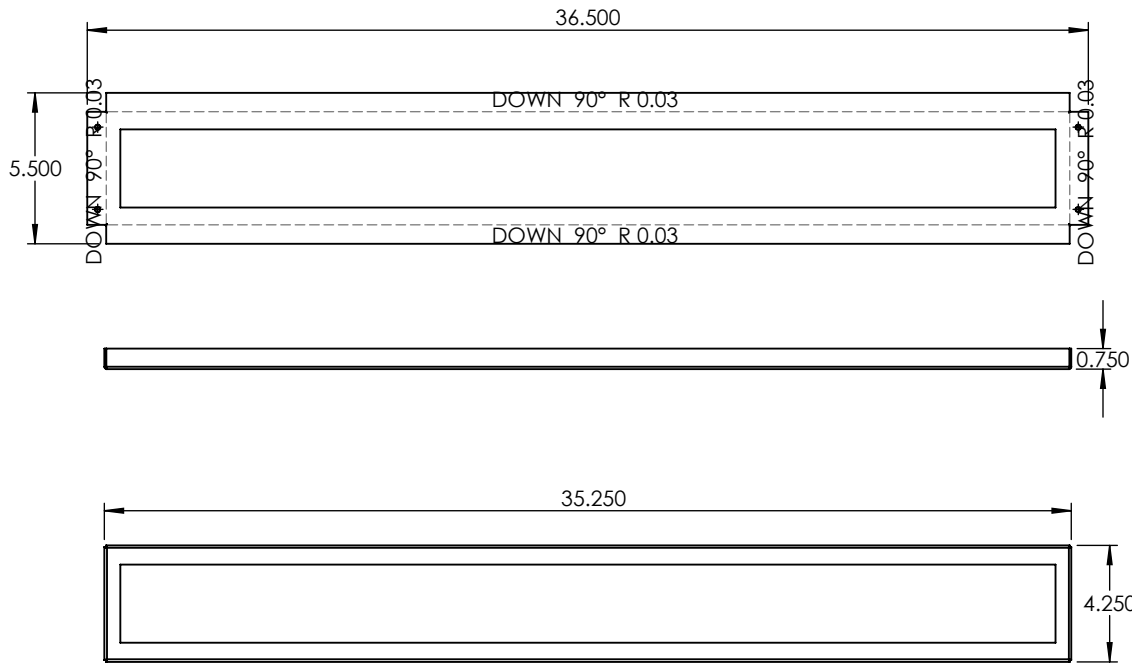

**PROPRIETARY AND CONFIDENTIAL**  
 THE INFORMATION CONTAINED IN THIS DRAWING IS THE SOLE PROPERTY OF <INSERT COMPANY NAME HERE>. ANY REPRODUCTION IN PART OR AS A WHOLE WITHOUT THE WRITTEN PERMISSION OF <INSERT COMPANY NAME HERE> IS PROHIBITED.

		UNLESS OTHERWISE SPECIFIED:	NAME	DATE
		DIMENSIONS ARE IN INCHES	DRAWN	
		TOLERANCES:	CHECKED	
		FRACTIONAL ±	ENG APPR.	
		ANGULAR: MACH ± BEND ±	MFG APPR.	
		TWO PLACE DECIMAL ±	Q.A.	
		THREE PLACE DECIMAL ±	COMMENTS:	
		INTERPRET GEOMETRIC TOLERANCING PER:		
		MATERIAL		
NEXT ASSY	USED ON	FINISH		
APPLICATION		DO NOT SCALE DRAWING		

ALUMINUM 0.0635"		
TITLE:		
OPSQVAN-36"-30L-MN-WF-DIM-35K		
SIZE	DWG. NO.	REV
<b>A</b>		
SCALE: 1:7	WEIGHT:	SHEET 8 OF 8

5

4

3

2

1