

ITEM NO.	PART NUMBER	DESCRIPTION	QTY.	CUT
1	PS-VNY-16W-MN-22-AEC-35K-FIREPLATE	22 GAUGE	1	
2	PS-VNY-16W-MN-22-AEC-35K-BACKPLATE	22 GAUGE	1	
3	PS-VNY-16W-MN-22-AEC-35K-BACKPLATE TAB	22 GAUGE	4	
4	PS-VNY-16W-MN-22-AEC-35K-FLOATING BACKFRAME	22 GAUGE	1	
5	PS-VNY-16W-MN-22-AEC-35K-FLOATING FRAME	22 GAUGE	1	
6	PS-VNY-16W-MN-22-AEC-35K-LED BRACKET	22 GAUGE	1	
7	PS-VNY-16W-MN-22-AEC-35K-ACCENT FRAME	22 GAUGE	1	
8	PS-VNY-16W-MN-22-AEC-35K-ALUMINUM BAR	3/8 SQUARE ALUMINUM BAR	1	
9	PS-VNY-16W-MN-22-AEC-35K-ACRYLIC	ACRYLIC	2	
10	DS-15W-350C1542010-3001	DRIVER	1	
12	AltaiLED_PN1010_RevD	LED	2	

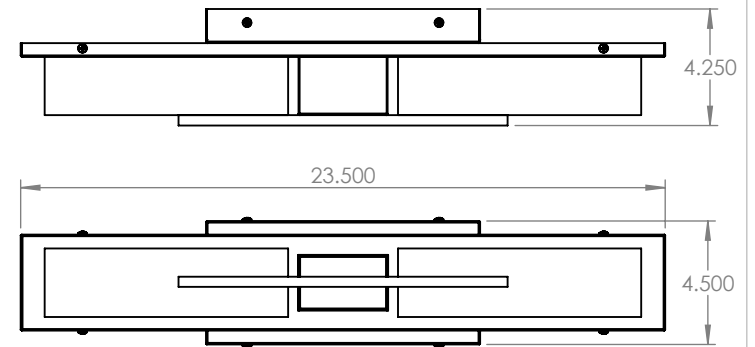
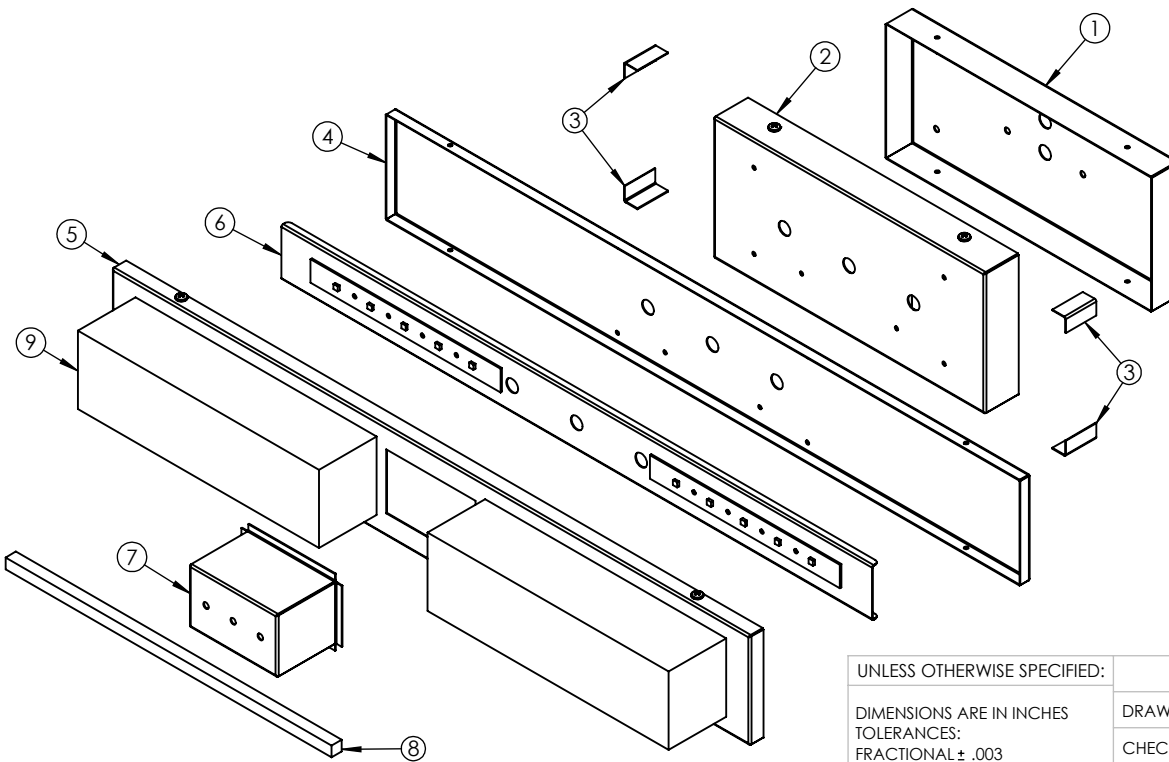
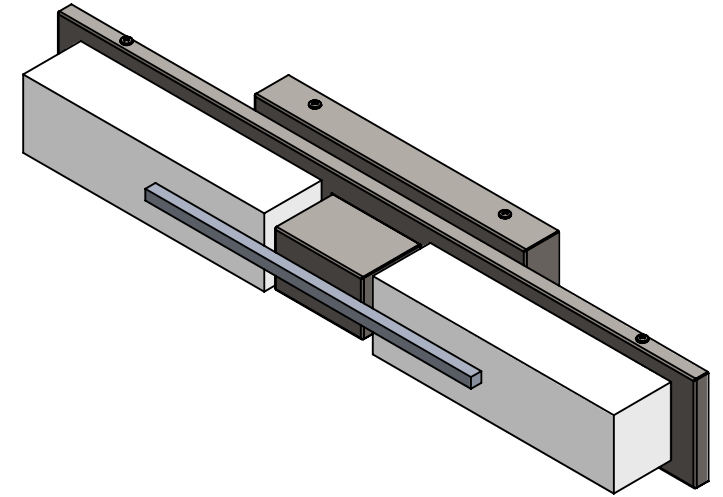

ALL BEND RADIUS .030"

APPLICATION

DO NOT SCALE DRAWING

UNLESS OTHERWISE SPECIFIED:

DIMENSIONS ARE IN INCHES
 TOLERANCES:
 FRACTIONAL ± .003
 ANGULAR: MACH ± .01 BEND ±
 TWO PLACE DECIMAL ±
 THREE PLACE DECIMAL ±.001

INTERPRET GEOMETRIC
 TOLERANCING PER:

MATERIAL

FINISH

NAME

DATE

DRAWN

CHECKED

ENG APPR.

MFG APPR.

Q.A.

COMMENTS:

TITLE:

PS-VNY-16W-MN-WF-22-AEC-35K

SIZE DWG. NO.

REV

A TICKET 26094

SCALE: 1:5

WEIGHT:

SHEET 1 OF 7

5

4

3

2

1

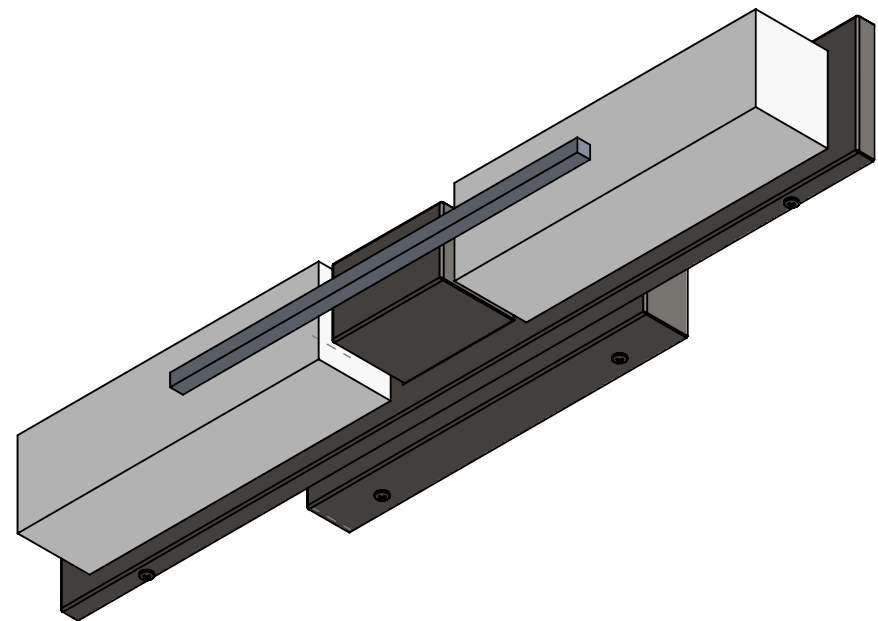
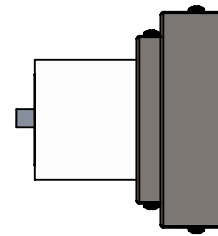
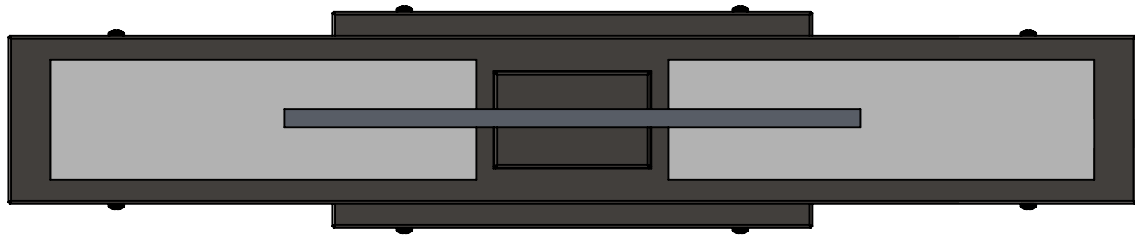
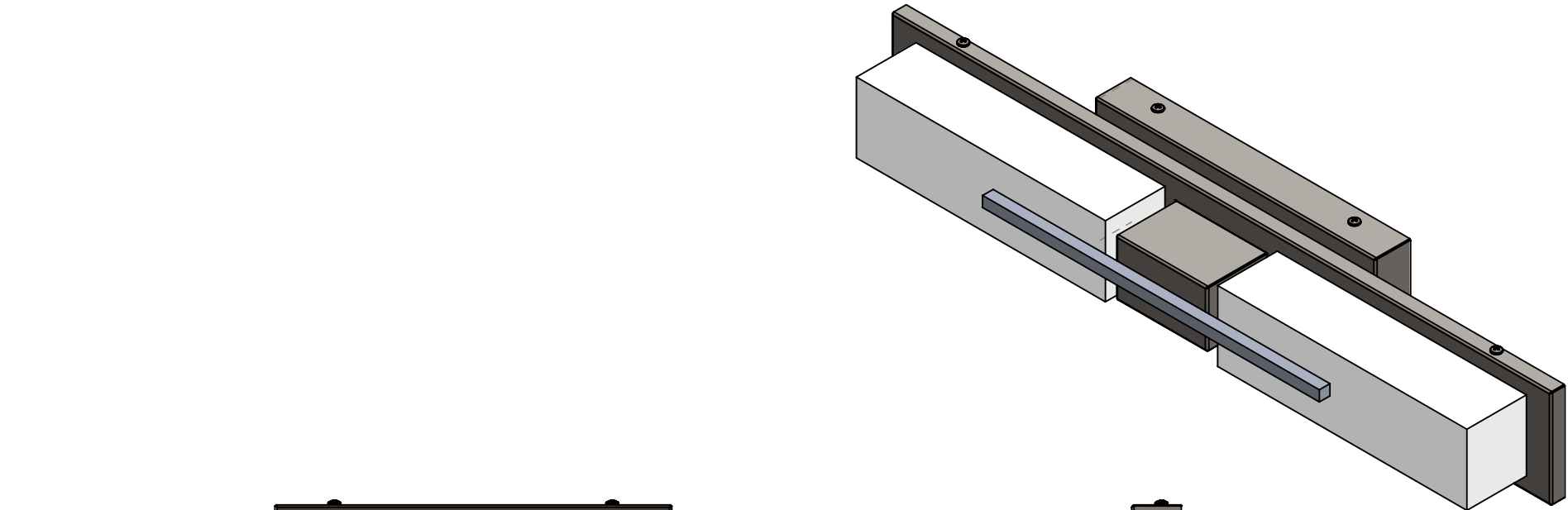

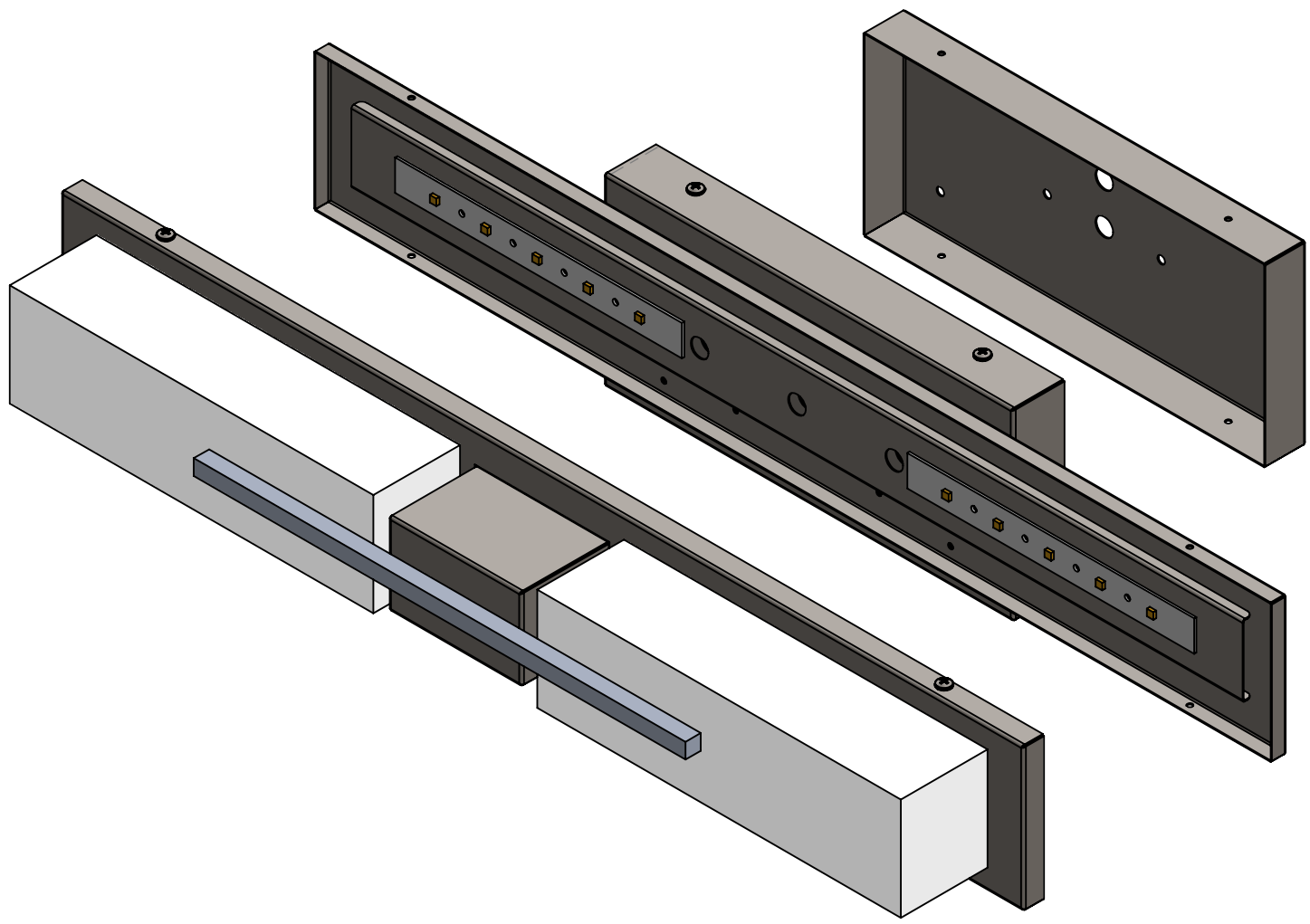

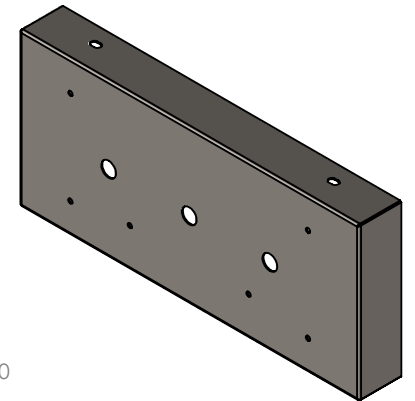
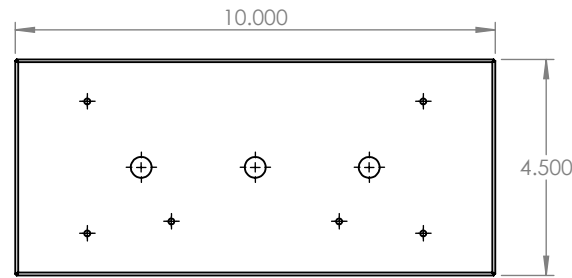
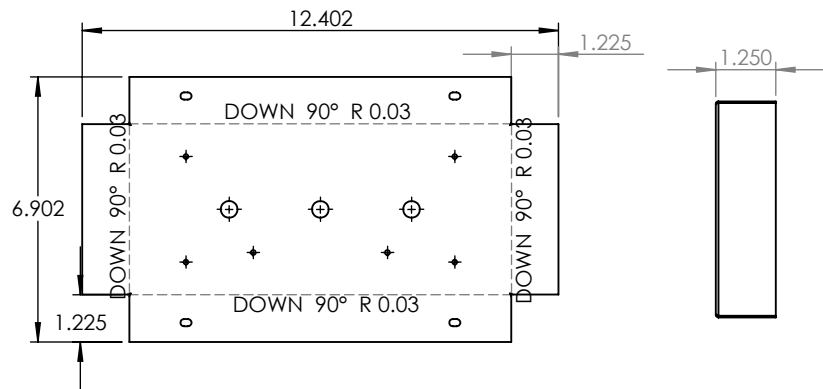
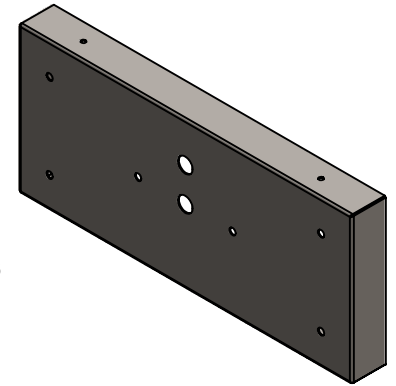
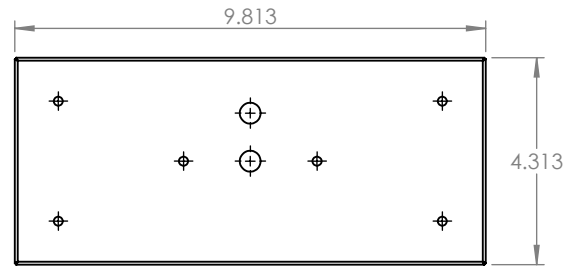
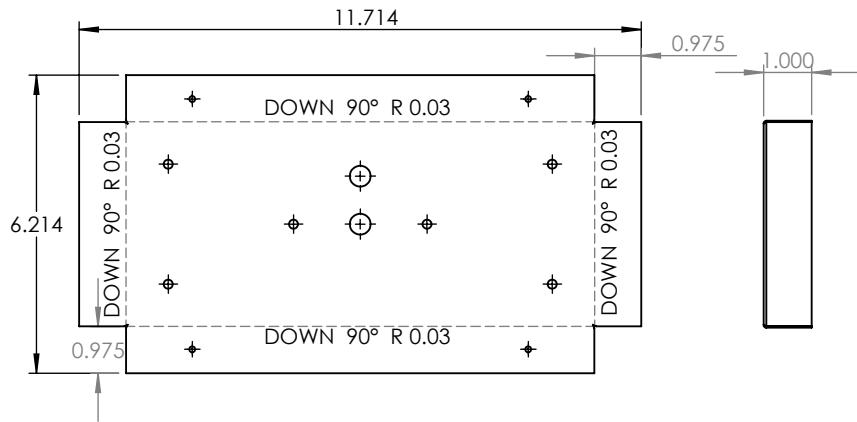

PROPRIETARY AND CONFIDENTIAL
 THE INFORMATION CONTAINED IN THIS DRAWING IS THE SOLE PROPERTY OF <INSERT COMPANY NAME HERE>. ANY REPRODUCTION IN PART OR AS A WHOLE WITHOUT THE WRITTEN PERMISSION OF <INSERT COMPANY NAME HERE> IS PROHIBITED.

		UNLESS OTHERWISE SPECIFIED:	NAME	DATE
		DIMENSIONS ARE IN INCHES	DRAWN	
		TOLERANCES:	CHECKED	
		FRACTIONAL ±	ENG APPR.	
		ANGULAR: MACH ± BEND ±	MFG APPR.	
		TWO PLACE DECIMAL ±	Q.A.	
		THREE PLACE DECIMAL ±	COMMENTS:	
		INTERPRET GEOMETRIC TOLERANCING PER:		
		MATERIAL		
NEXT ASSY	USED ON	FINISH		
APPLICATION		DO NOT SCALE DRAWING		

22 GAUGE		
TITLE:		
PS-VNY-16W-MN-WF-22-AEC-35K		
SIZE	DWG. NO.	REV
A		
SCALE: 1:4	WEIGHT:	SHEET 4 OF 7

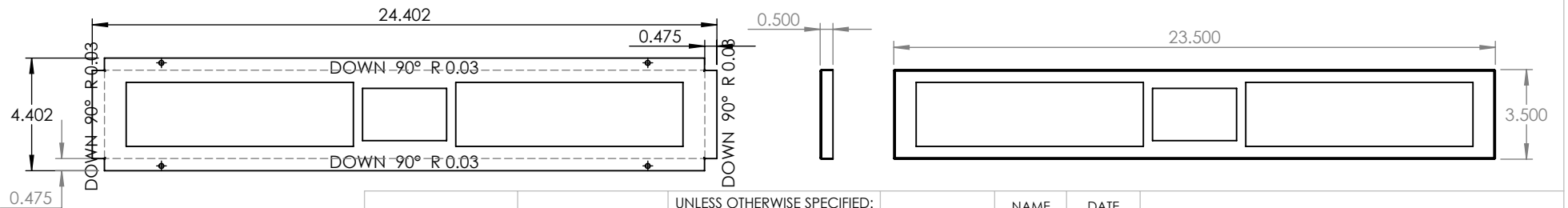
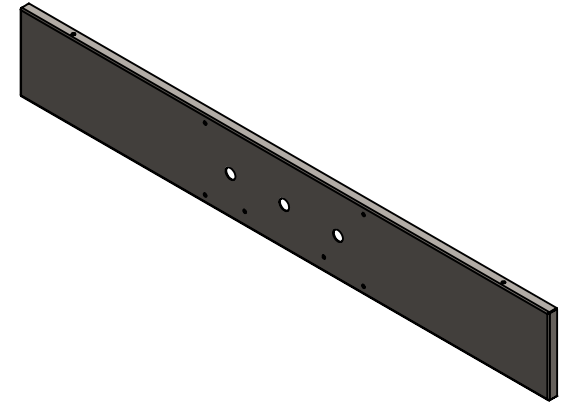
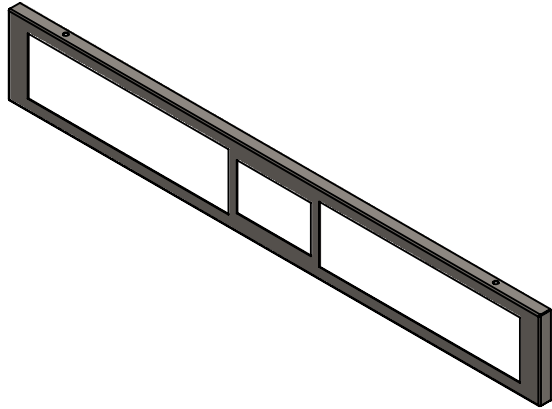
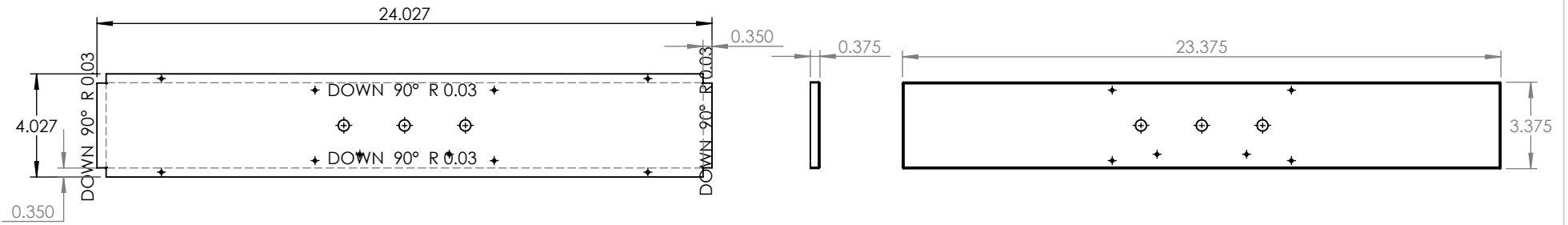

PROPRIETARY AND CONFIDENTIAL
 THE INFORMATION CONTAINED IN THIS DRAWING IS THE SOLE PROPERTY OF <INSERT COMPANY NAME HERE>. ANY REPRODUCTION IN PART OR AS A WHOLE WITHOUT THE WRITTEN PERMISSION OF <INSERT COMPANY NAME HERE> IS PROHIBITED.

		UNLESS OTHERWISE SPECIFIED:
		DIMENSIONS ARE IN INCHES
		TOLERANCES:
		FRACTIONAL ±
		ANGULAR: MACH ± BEND ±
		TWO PLACE DECIMAL ±
		THREE PLACE DECIMAL ±
		INTERPRET GEOMETRIC TOLERANCING PER:
		MATERIAL
		FINISH
NEXT ASSY	USED ON	
APPLICATION		DO NOT SCALE DRAWING

	NAME	DATE
DRAWN		
CHECKED		
ENG APPR.		
MFG APPR.		
Q.A.		
COMMENTS:		

22 GAUGE		
TITLE:		
PS-VNY-16W-MN-WF-22-AEC-35K		
SIZE	DWG. NO.	REV
A		
SCALE: 1:6	WEIGHT:	SHEET 5 OF 7

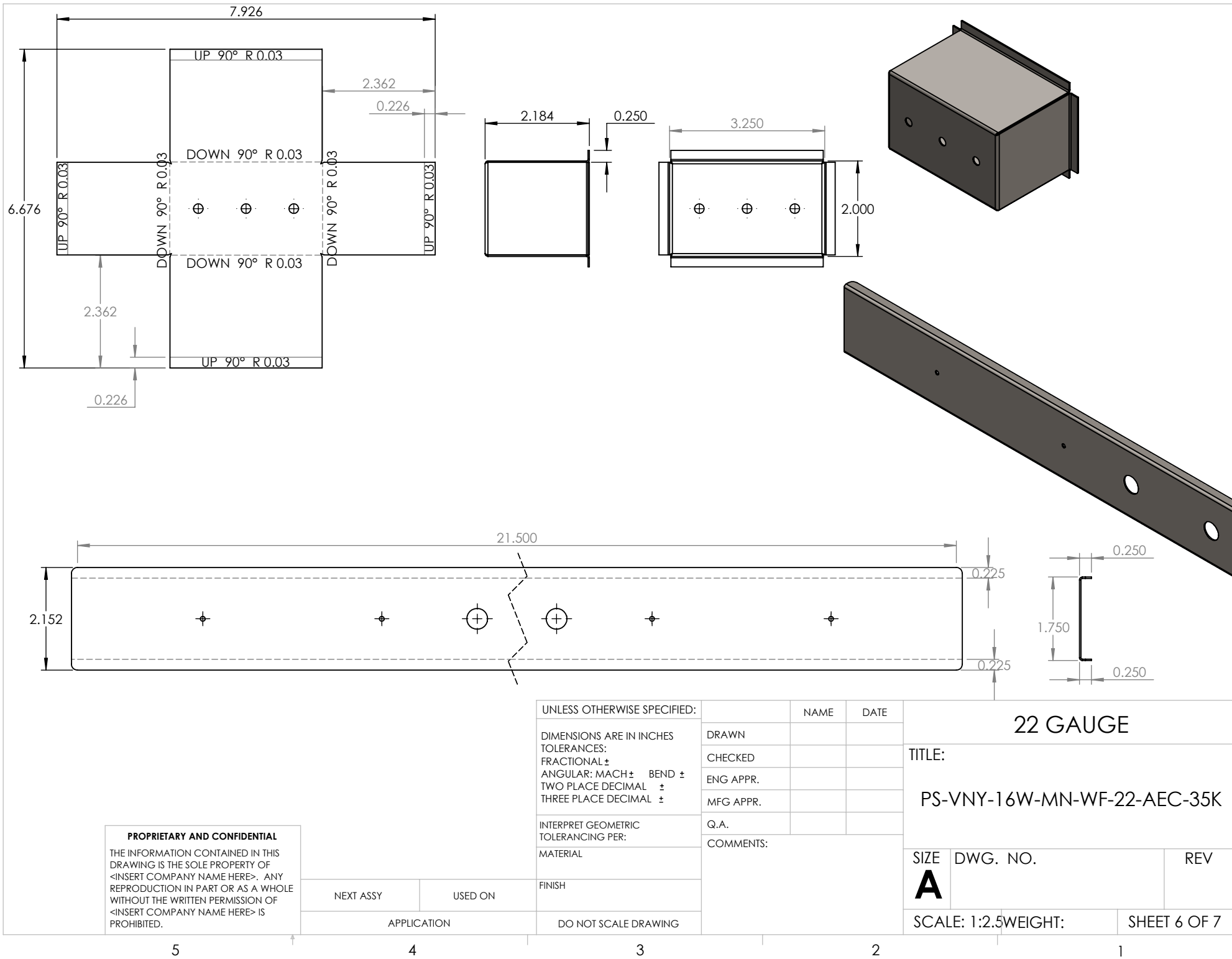

PROPRIETARY AND CONFIDENTIAL
 THE INFORMATION CONTAINED IN THIS DRAWING IS THE SOLE PROPERTY OF <INSERT COMPANY NAME HERE>. ANY REPRODUCTION IN PART OR AS A WHOLE WITHOUT THE WRITTEN PERMISSION OF <INSERT COMPANY NAME HERE> IS PROHIBITED.

UNLESS OTHERWISE SPECIFIED:		NAME	DATE
DIMENSIONS ARE IN INCHES		DRAWN	
TOLERANCES:		CHECKED	
FRACTIONAL ±		ENG APPR.	
ANGULAR: MACH ± BEND ±		MFG APPR.	
TWO PLACE DECIMAL ±		Q.A.	
THREE PLACE DECIMAL ±		COMMENTS:	
INTERPRET GEOMETRIC TOLERANCING PER:			
MATERIAL			
FINISH			
NEXT ASSY	USED ON		
APPLICATION			
DO NOT SCALE DRAWING			

22 GAUGE		
TITLE:		
PS-VNY-16W-MN-WF-22-AEC-35K		
SIZE	DWG. NO.	REV
A		
SCALE: 1:2.5WEIGHT:		SHEET 6 OF 7

5

4

3

2

1

