

ITEM NO.	PART NUMBER	DESCRIPTION	QTY.	CUT
1	EV-MDG-SQR-ADR-6W-ORB-CA-30K-TOP FRAME	18 GAUGE	1	
2	EV-MDG-SQR-ADR-6W-ORB-CA-30K-BOTTOM FRAME	18 GAUGE	1	
3	EV-MDG-SQR-ADR-6W-ORB-CA-30K-FRAME PLATE	22 GAUGE	1	
4	EV-MDG-SQR-ADR-6W-ORB-CA-30K-FRAME TAB	22 GAUGE	4	
5	EV-MDG-SQR-ADR-6W-ORB-CA-30K-FRAME NUMBERS PLATE	22 GAUGE	1	
6	EV-MDG-SQR-ADR-6W-ORB-CA-30K-BACKPLATE	22 GAUGE	1	
7	EV-MDG-SQR-ADR-6W-ORB-CA-30K-FIREPLATE	22 GAUGE	1	
8	EV-MDG-SQR-ADR-6W-ORB-CA-30K-LED BRACKET	22 GAUGE	1	
9	EV-MDG-SQR-ADR-6W-ORB-CA-30K-ACRYLIC	ACRYLIC	1	
10	DS-15W-350C1542010-3001	DRIVER	1	
11	Altailed PN1012 RevD	LED	1	

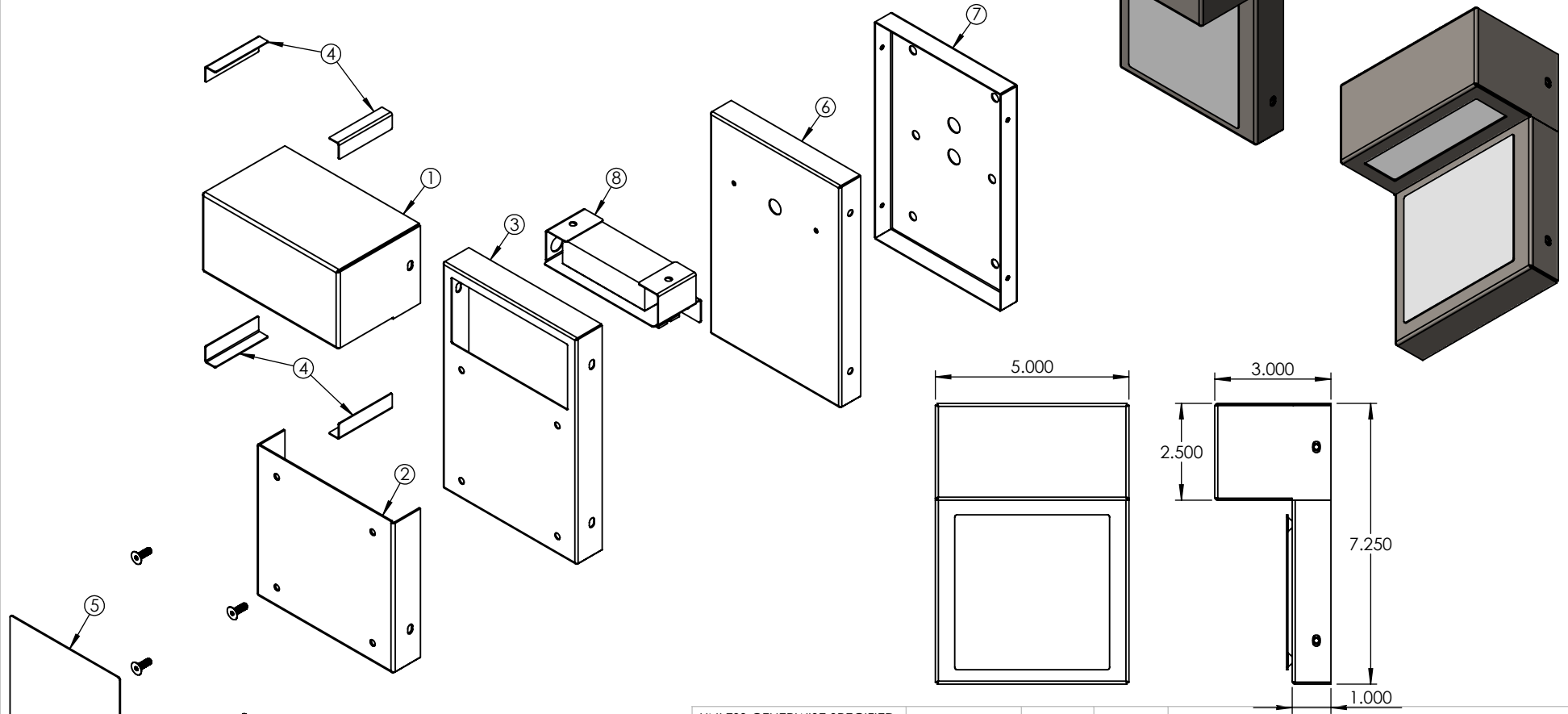

ALL BEND RADIUS .030"

APPLICATION

DO NOT SCALE DRAWING

UNLESS OTHERWISE SPECIFIED:

DIMENSIONS ARE IN INCHES
 TOLERANCES:
 FRACTIONAL ± .003
 ANGULAR: MACH ± .01 BEND ±
 TWO PLACE DECIMAL ±
 THREE PLACE DECIMAL ±.001

INTERPRET GEOMETRIC
 TOLERANCING PER:

MATERIAL

FINISH

NAME

DATE

DRAWN

CHECKED

ENG APPR.

MFG APPR.

Q.A.

COMMENTS:

TITLE:

EV-MDG-SQR-ADR-6W-ORB-CA-30K

SIZE DWG. NO.

REV

A TICKET 26118

SCALE: 1:4

WEIGHT:

SHEET 1 OF 7

5

4

3

2

1

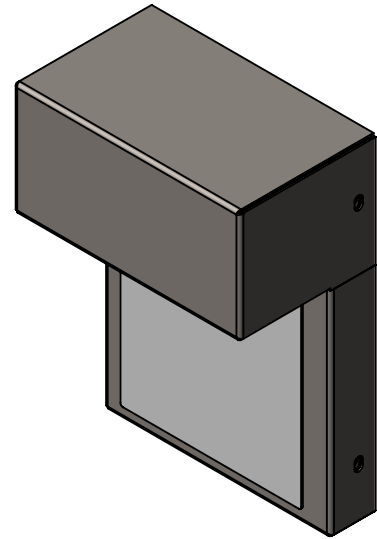
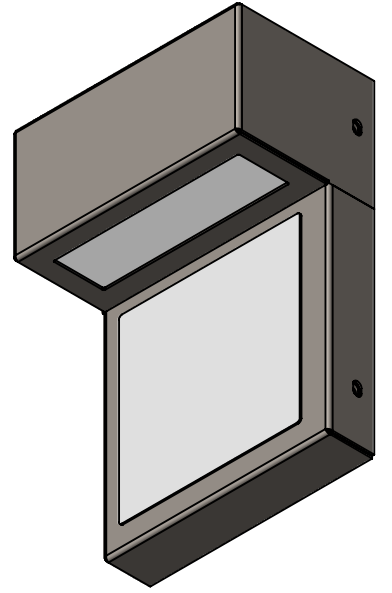
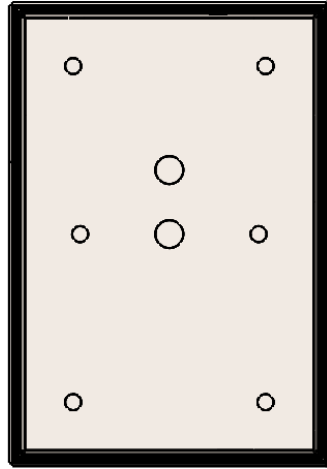
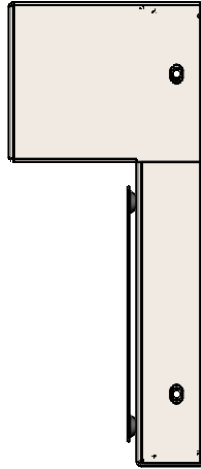
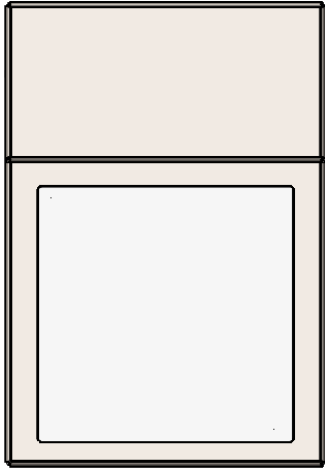

SPOT WELDED AS ONE

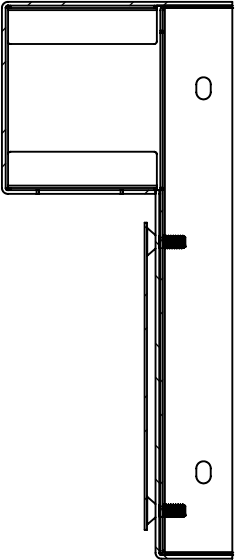
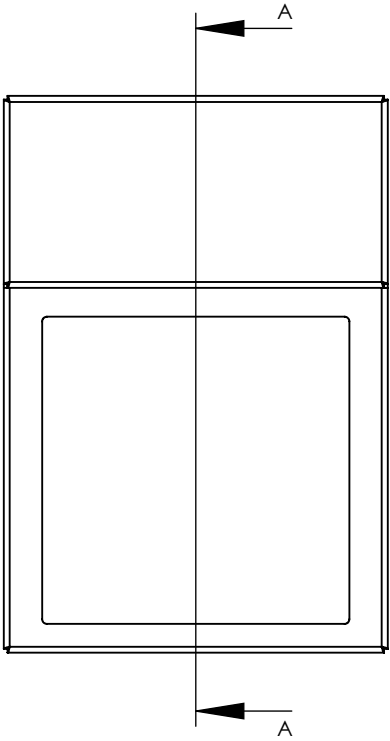
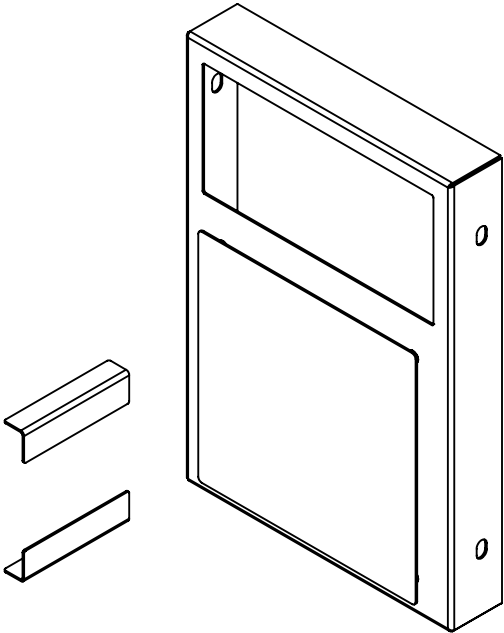
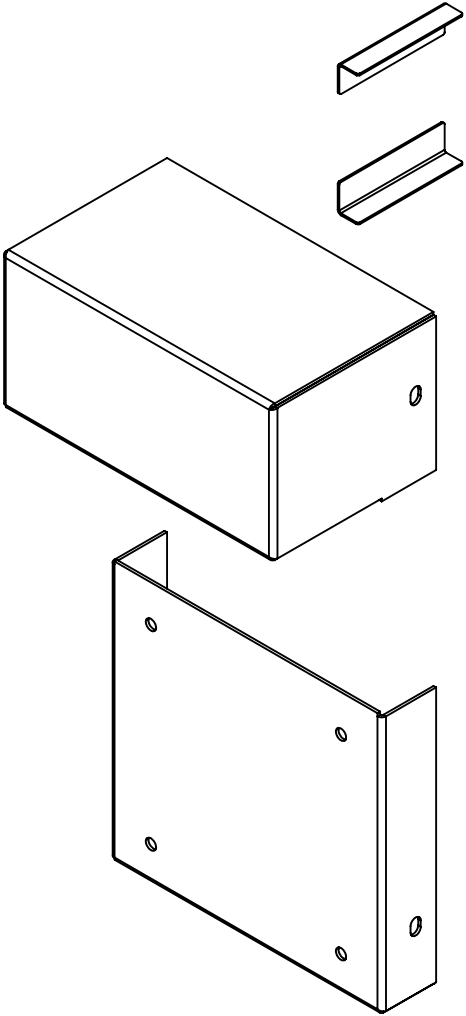

SECTION A-A

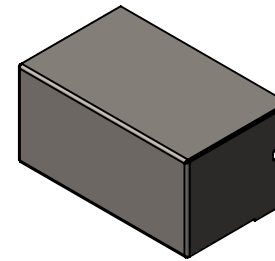
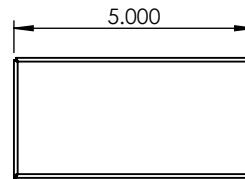
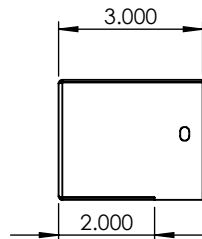
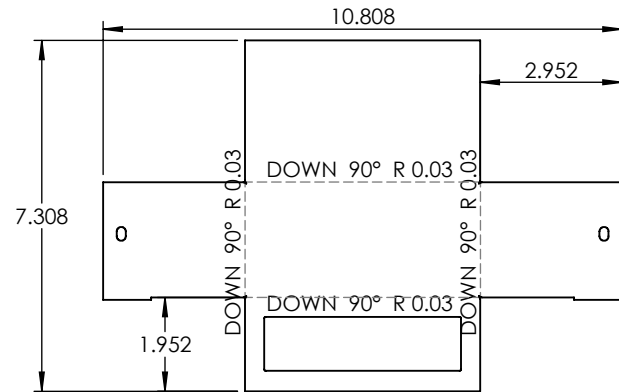
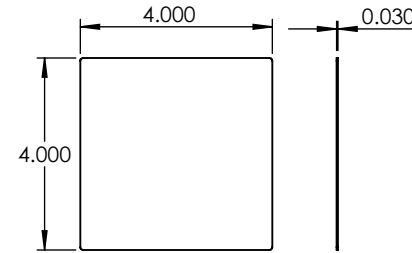
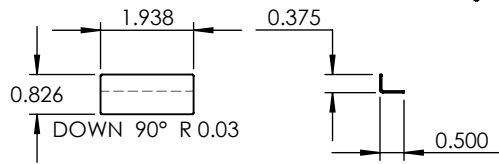

PROPRIETARY AND CONFIDENTIAL
 THE INFORMATION CONTAINED IN THIS DRAWING IS THE SOLE PROPERTY OF <INSERT COMPANY NAME HERE>. ANY REPRODUCTION IN PART OR AS A WHOLE WITHOUT THE WRITTEN PERMISSION OF <INSERT COMPANY NAME HERE> IS PROHIBITED.

		UNLESS OTHERWISE SPECIFIED:	NAME	DATE	18 GAUGE	
		DIMENSIONS ARE IN INCHES TOLERANCES: FRACTIONAL ± ANGULAR: MACH ± BEND ± TWO PLACE DECIMAL ± THREE PLACE DECIMAL ±	DRAWN			
		INTERPRET GEOMETRIC TOLERANCING PER:	CHECKED		SIZE DWG. NO. REV	
		MATERIAL	ENG APPR.			
		FINISH	MFG APPR.			
NEXT ASSY	USED ON	APPLICATION	Q.A.			
		DO NOT SCALE DRAWING	COMMENTS:			

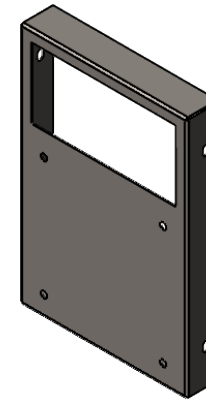
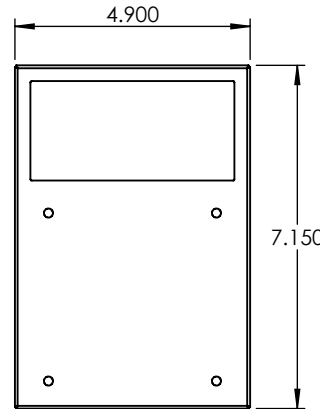
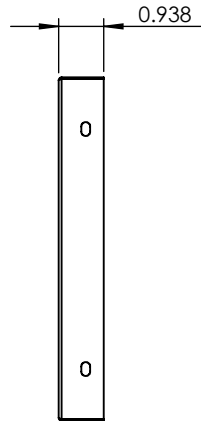
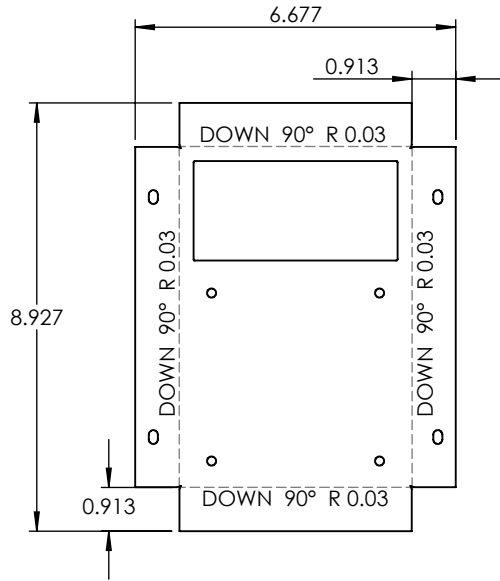
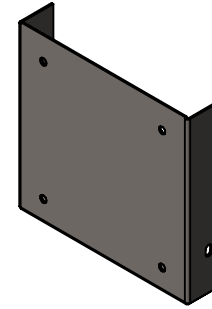
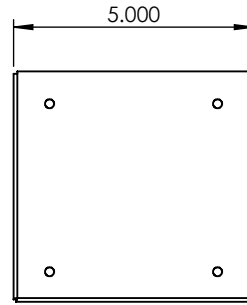
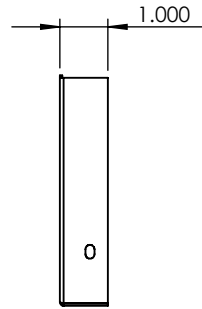
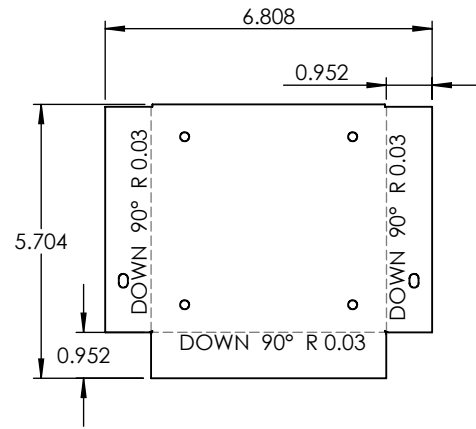

UNLESS OTHERWISE SPECIFIED:

DIMENSIONS ARE IN INCHES
 TOLERANCES:
 FRACTIONAL ±
 ANGULAR: MACH ± BEND ±
 TWO PLACE DECIMAL ±
 THREE PLACE DECIMAL ±

INTERPRET GEOMETRIC
 TOLERANCING PER:

MATERIAL

FINISH

DO NOT SCALE DRAWING

NAME

DATE

22 GAUGE

DRAWN

CHECKED

ENG APPR.

MFG APPR.

Q.A.

COMMENTS:

TITLE:

EV-MDG-SQR-ADR-6W-ORB-CA-30K

SIZE DWG. NO.

REV

A

SCALE: 1:4

WEIGHT:

SHEET 5 OF 7

PROPRIETARY AND CONFIDENTIAL
 THE INFORMATION CONTAINED IN THIS
 DRAWING IS THE SOLE PROPERTY OF
 <INSERT COMPANY NAME HERE>. ANY
 REPRODUCTION IN PART OR AS A WHOLE
 WITHOUT THE WRITTEN PERMISSION OF
 <INSERT COMPANY NAME HERE> IS
 PROHIBITED.

NEXT ASSY

USED ON

APPLICATION

5

4

3

2

1

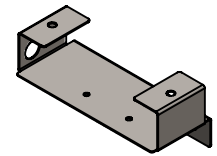
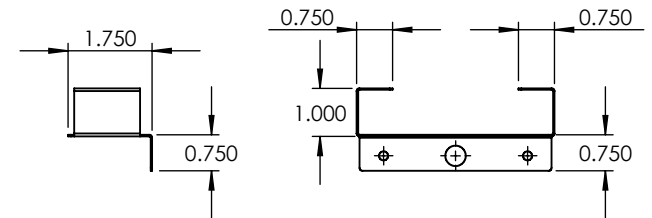
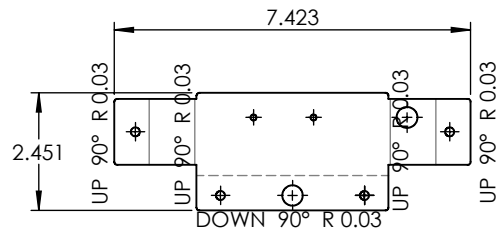
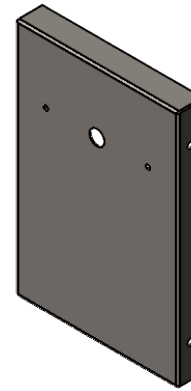
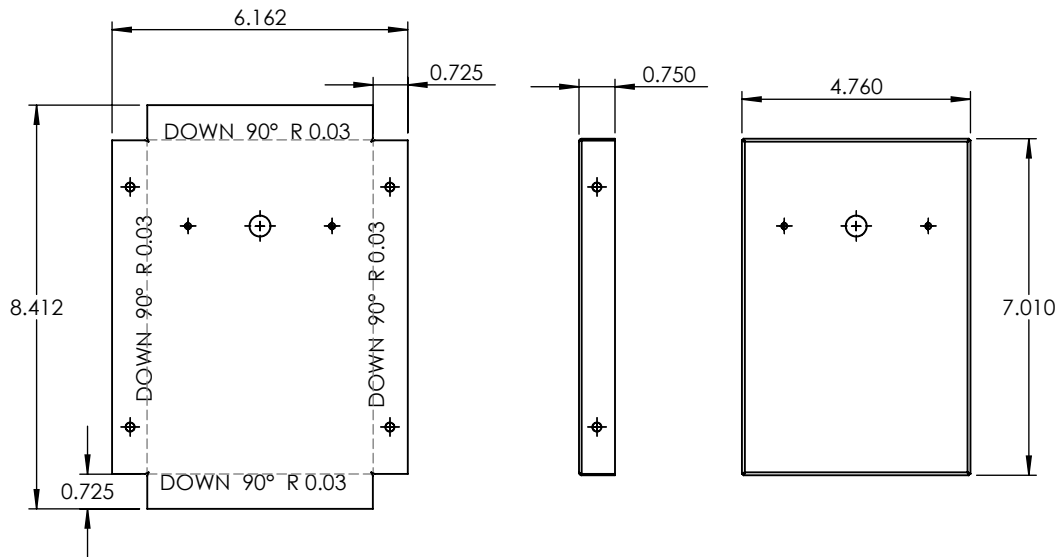

UNLESS OTHERWISE SPECIFIED:		NAME	DATE	22 GAUGE	
DIMENSIONS ARE IN INCHES TOLERANCES: FRACTIONAL ± ANGULAR: MACH ± BEND ± TWO PLACE DECIMAL ± THREE PLACE DECIMAL ±		DRAWN			
INTERPRET GEOMETRIC TOLERANCING PER:		CHECKED		EV-MDG-SQR-ADR-6W-ORB-CA-30K	
		ENG APPR.			
MATERIAL		MFG APPR.		SIZE DWG. NO. REV	
		Q.A.			
FINISH		COMMENTS:		SCALE: 1:4 WEIGHT: SHEET 6 OF 7	
DO NOT SCALE DRAWING					

PROPRIETARY AND CONFIDENTIAL
THE INFORMATION CONTAINED IN THIS DRAWING IS THE SOLE PROPERTY OF <INSERT COMPANY NAME HERE>. ANY REPRODUCTION IN PART OR AS A WHOLE WITHOUT THE WRITTEN PERMISSION OF <INSERT COMPANY NAME HERE> IS PROHIBITED.

NEXT ASSY	USED ON
APPLICATION	

5

4

3

2

1

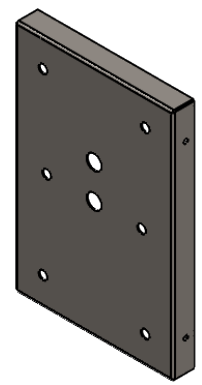
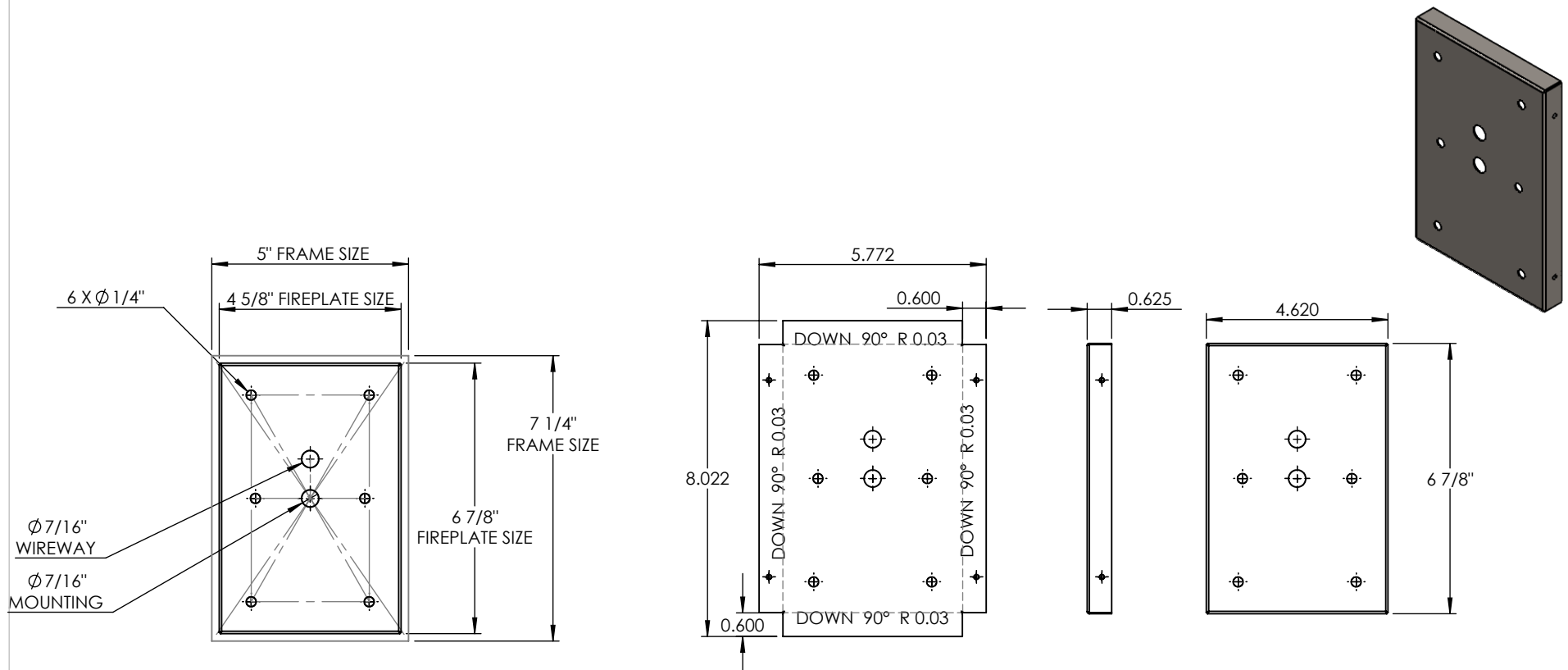

PROPRIETARY AND CONFIDENTIAL
THE INFORMATION CONTAINED IN THIS DRAWING IS THE SOLE PROPERTY OF <INSERT COMPANY NAME HERE>. ANY REPRODUCTION IN PART OR AS A WHOLE WITHOUT THE WRITTEN PERMISSION OF <INSERT COMPANY NAME HERE> IS PROHIBITED.

NEXT ASSY	USED ON
APPLICATION	

UNLESS OTHERWISE SPECIFIED:
DIMENSIONS ARE IN INCHES
TOLERANCES:
FRACTIONAL ±
ANGULAR: MACH ± BEND ±
TWO PLACE DECIMAL ±
THREE PLACE DECIMAL ±
INTERPRET GEOMETRIC TOLERANCING PER:
MATERIAL
FINISH
DO NOT SCALE DRAWING

NAME	DATE
DRAWN	
CHECKED	
ENG APPR.	
MFG APPR.	
Q.A.	
COMMENTS:	

22 GAUGE		
TITLE:		
EV-MDG-SQR-ADR-6W-ORB-CA-30K		
SIZE	DWG. NO.	REV
A		
SCALE: 1:4	WEIGHT:	SHEET 7 OF 7