

ALL BEND RADIUS .030"

APPLICATION

DO NOT SCALE DRAWING

UNLESS OTHERWISE SPECIFIED:

DIMENSIONS ARE IN INCHES
 TOLERANCES:
 FRACTIONAL ± .003
 ANGULAR: MACH ± .01 BEND ±
 TWO PLACE DECIMAL ±
 THREE PLACE DECIMAL ±.001

INTERPRET GEOMETRIC
 TOLERANCING PER:

MATERIAL

FINISH

NAME

DATE

DRAWN

CHECKED

ENG APPR.

MFG APPR.

Q.A.

COMMENTS:

TITLE:

2400-15"-24W9-CFAHF-EMR-WET-41K

SIZE DWG. NO.

REV

A TICKET 26145

SCALE: 1:5

WEIGHT:

SHEET 1 OF 8

5

4

3

2

1

ITEM NO.	PART NUMBER	DESCRIPTION	QTY.	CUT
1	2400-15"-24W-9-CFA-EMR-WET-FRAME COVER	ALUMINUM 0.250" PLATE	1	
2	2400-15"-24W-9-CFA-EMR-WET-41K-BACKPLATE STRAP EMR	ALUMINUM 0.125" PLATE	1	
3	2400-15"-24W-9-CFA-EMR-WET-BACKPLATE STRAP	ALUMINUM 0.125" PLATE	1	
4	2400-15"-24W-9-CFA-EMR-WET-BACKPLATE BRACKET	ALUMINUM 0.125" PLATE	1	
5	2400-15"-24W-9-CFA-EMR-WET-BACKPLATE	ALUMINUM 0.125" PLATE	1	
6	2400-15"-24W-9-CFA-EMR-WET-LED BRACKET	ALUMINUM 0.635"	1	
7	2400-15"-24W-9-CFA-EMR-WET-LED PLATE	ALUMINUM 0.635"	1	
8	2400-15"-24W-9-CFA-EMR-WET-FRAME BAR	1/2" X 1/4" ALUMINUM BAR	1	
9	2400-15"-24W-9-CFA-EMR-WET-FRAME BAR	1/2" X 1/4" ALUMINUM BAR	1	
10	2400-15"-24W-9-CFA-EMR-WET-ACRYLIC	MOLDED ACRYLIC	1	
11	EMR BUTTON	BUTTON	1	
12	ACE-G10-55-190-EMR PACK	DRIVER-BATTERY	1	
13	ESPEL29070MVH-1	DRIVER	1	
14	AltaiLED_PN1004RevD	LED	4	

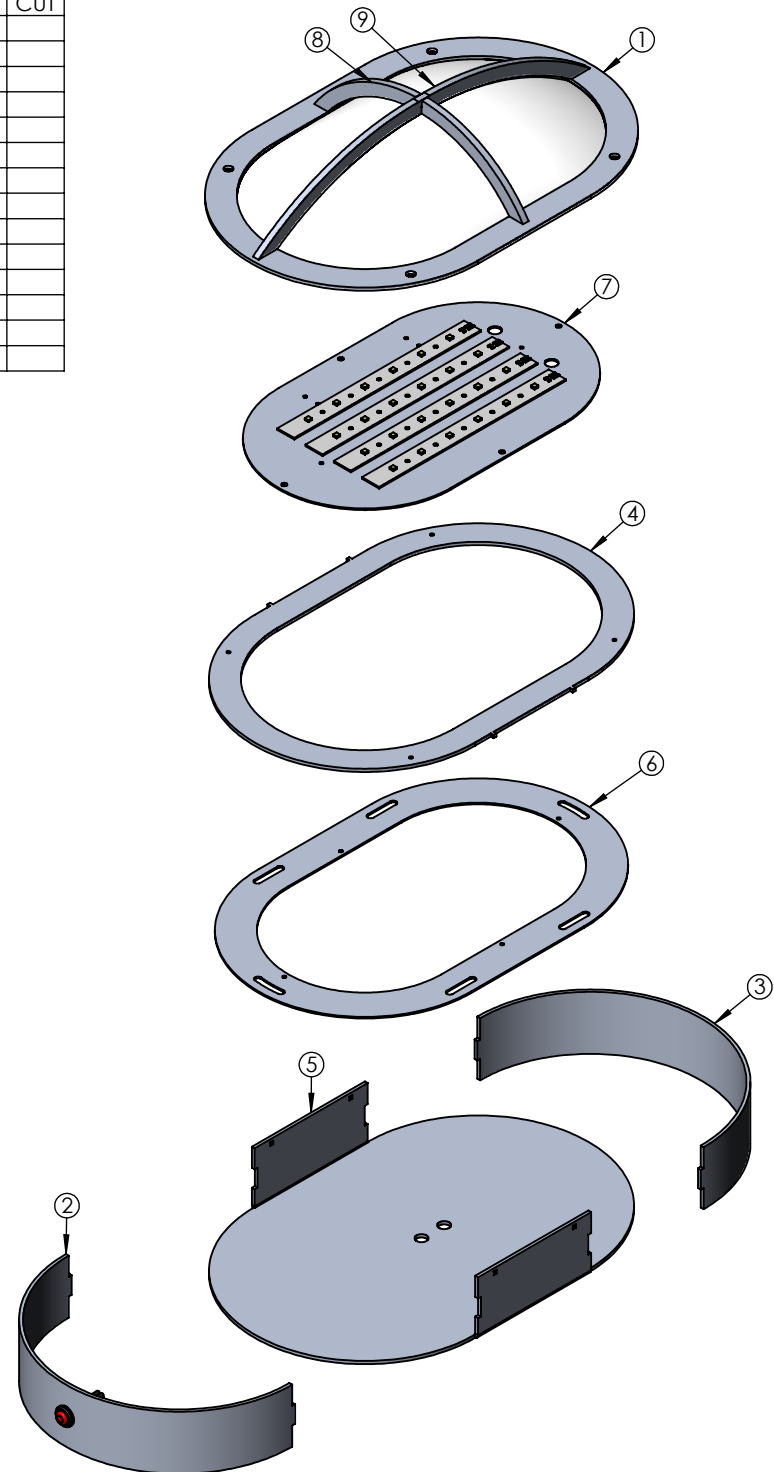

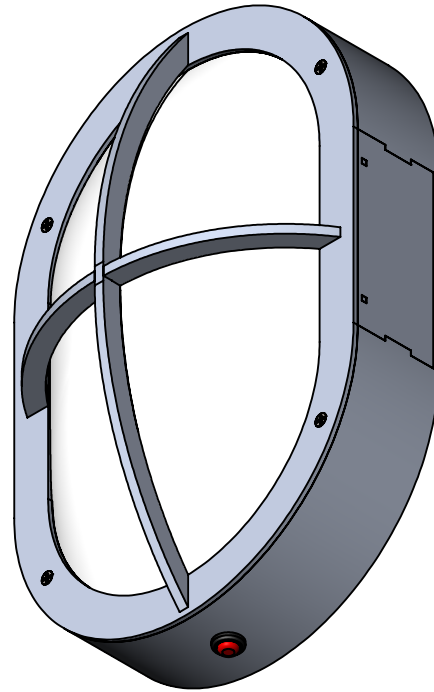
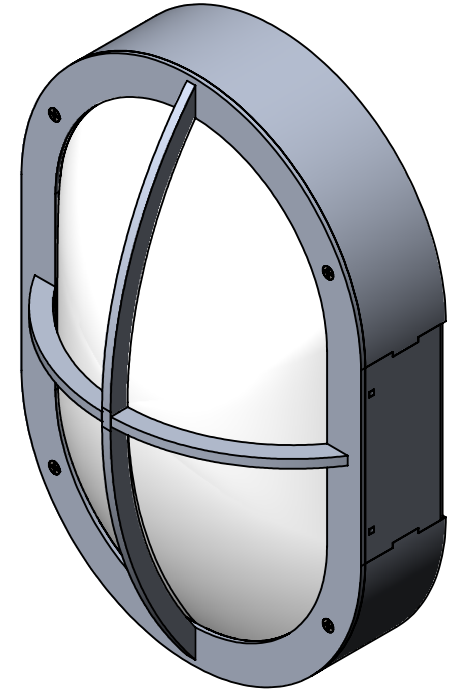
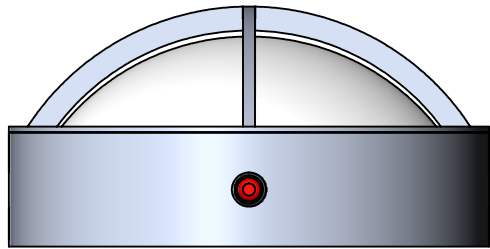
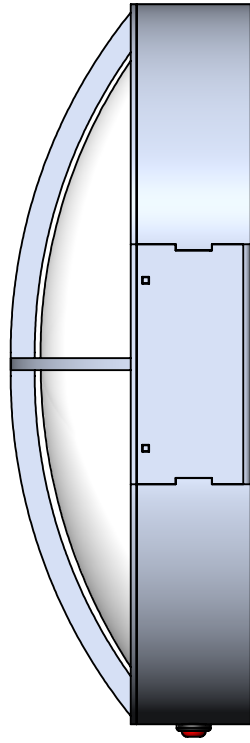
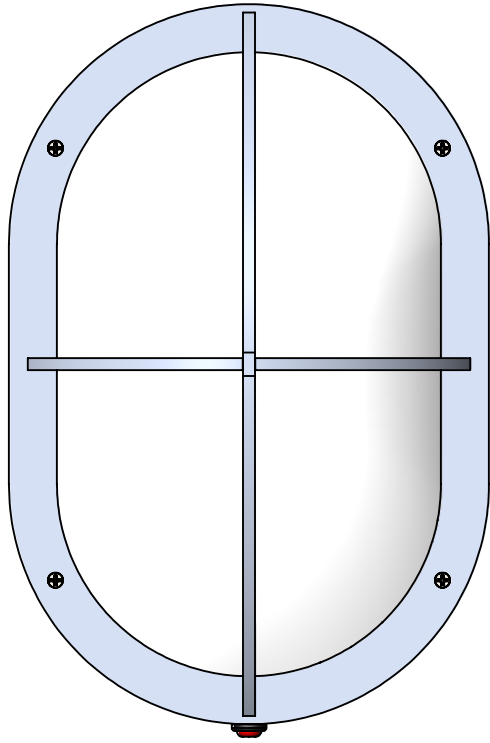

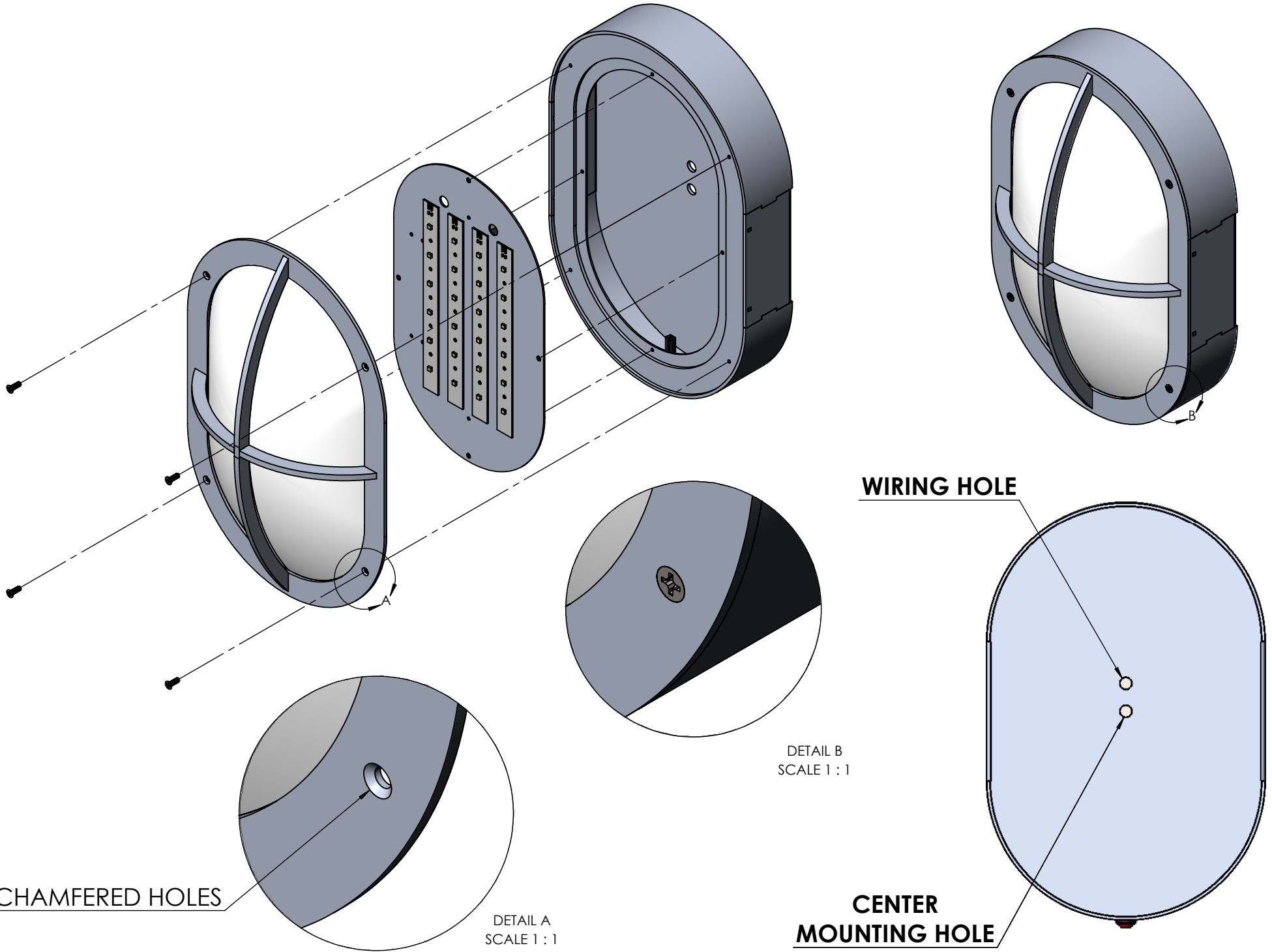

CHAMFERED HOLES

DETAIL A
SCALE 1 : 1

WIRING HOLE

DETAIL B
SCALE 1 : 1

CENTER
MOUNTING HOLE

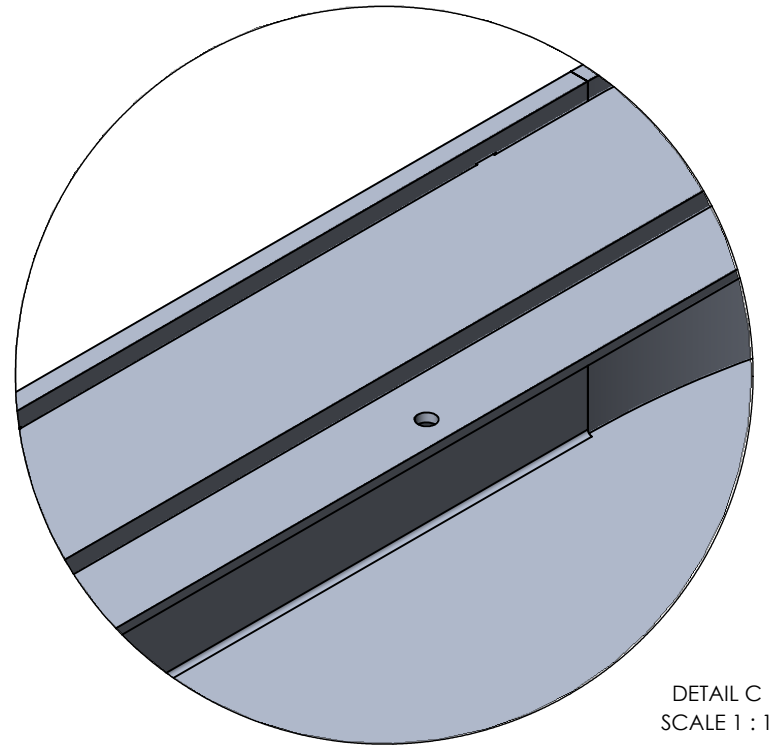
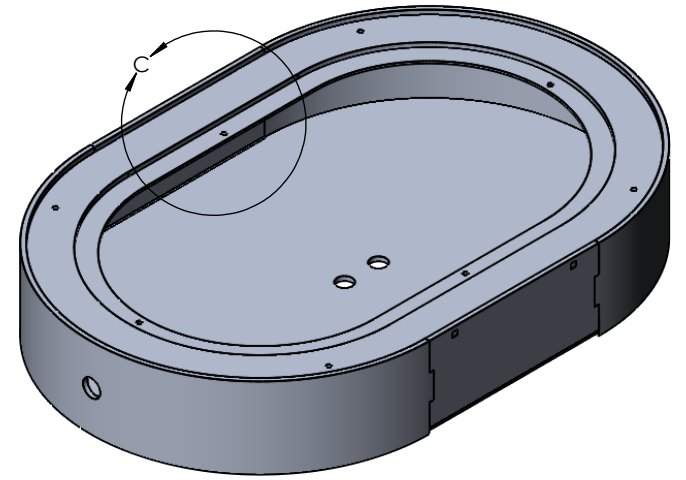
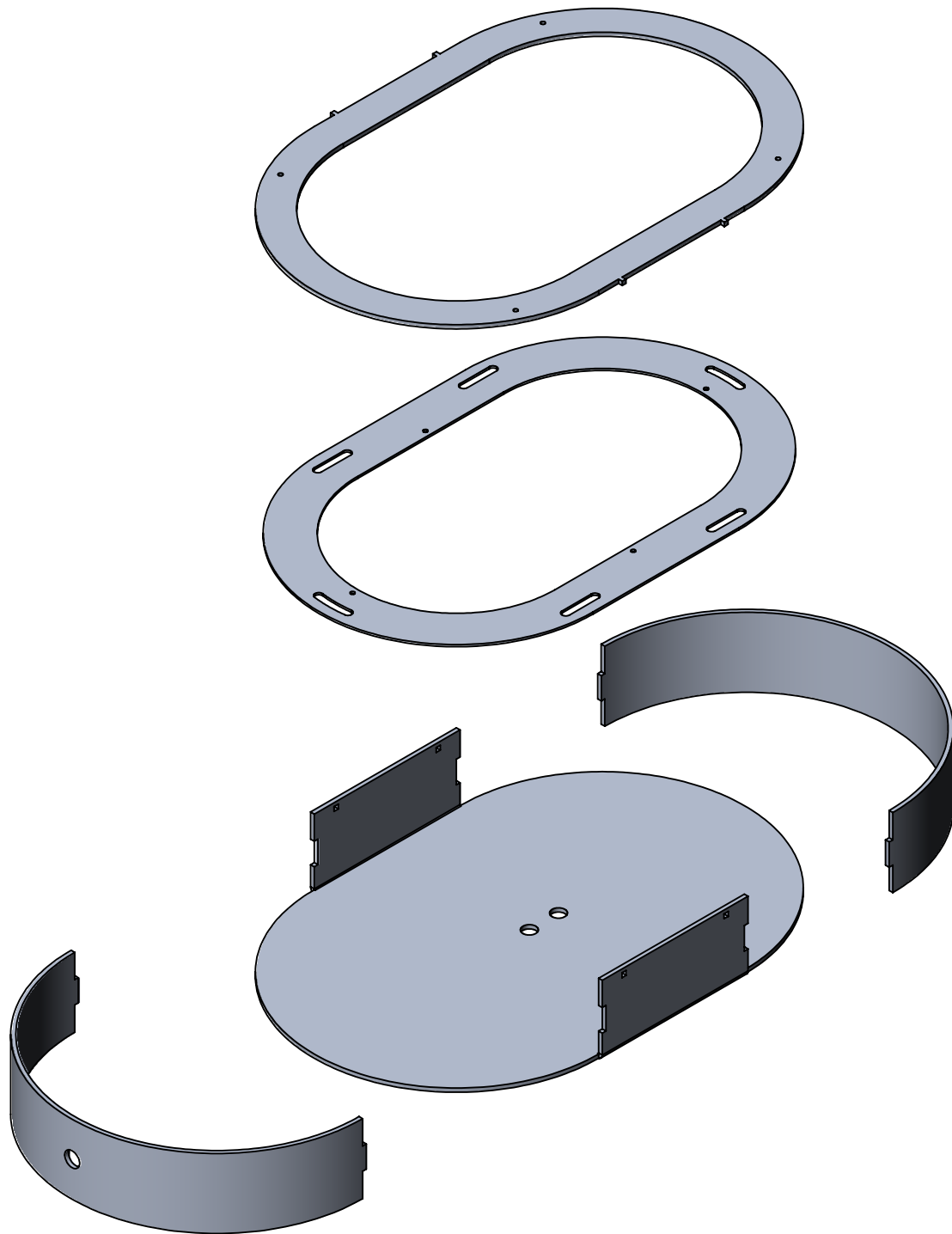

DETAIL C
SCALE 1 : 1

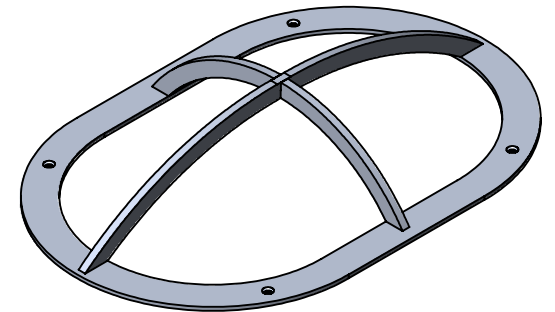
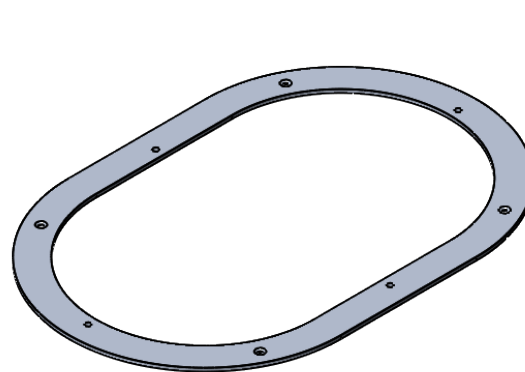
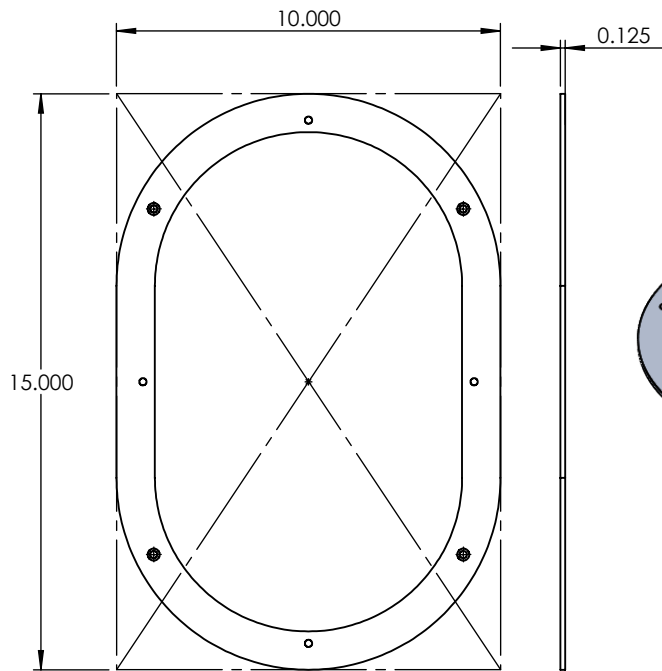

UNLESS OTHERWISE SPECIFIED:		NAME	DATE	ALUMINUM 0.250" PLATE	
DIMENSIONS ARE IN INCHES TOLERANCES: FRACTIONAL ± ANGULAR: MACH ± BEND ± TWO PLACE DECIMAL ± THREE PLACE DECIMAL ±		DRAWN			
INTERPRET GEOMETRIC TOLERANCING PER:		CHECKED		2400-15"-24W9-CFAHF-EMR-WET-41K	
		ENG APPR.			
MATERIAL		MFG APPR.		SIZE DWG. NO. REV	
		Q.A.			
FINISH		COMMENTS:		SCALE: 1:5 WEIGHT: SHEET 6 OF 8	
NEXT ASSY		USED ON			
APPLICATION		DO NOT SCALE DRAWING			

PROPRIETARY AND CONFIDENTIAL
THE INFORMATION CONTAINED IN THIS DRAWING IS THE SOLE PROPERTY OF <INSERT COMPANY NAME HERE>. ANY REPRODUCTION IN PART OR AS A WHOLE WITHOUT THE WRITTEN PERMISSION OF <INSERT COMPANY NAME HERE> IS PROHIBITED.

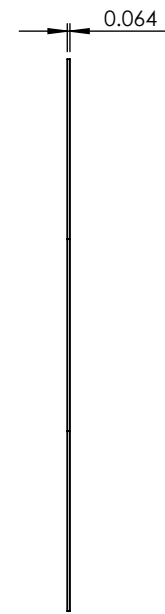
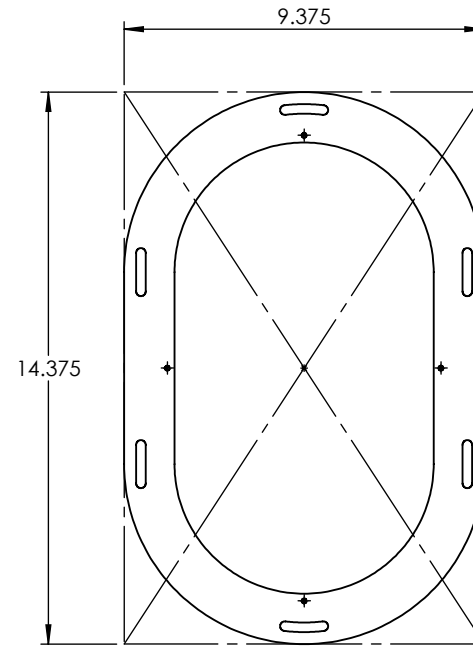
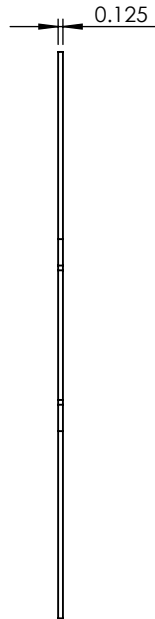
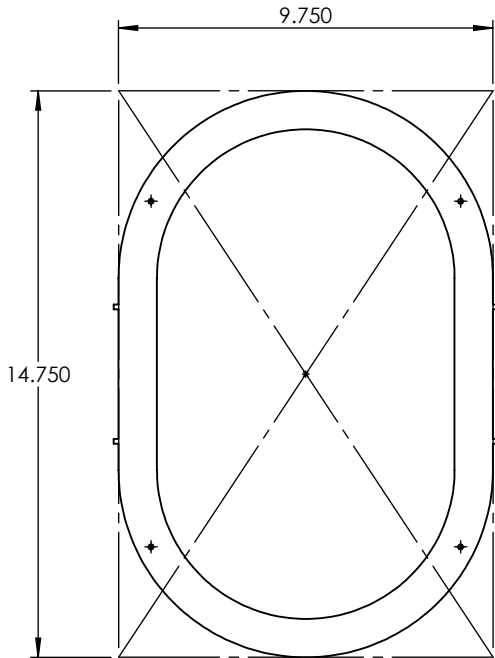
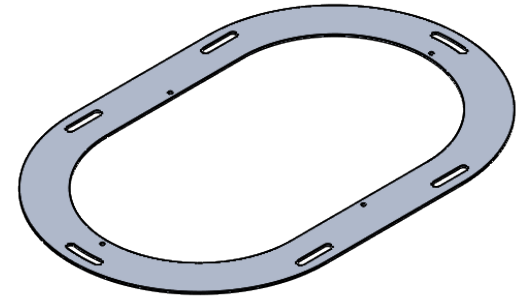
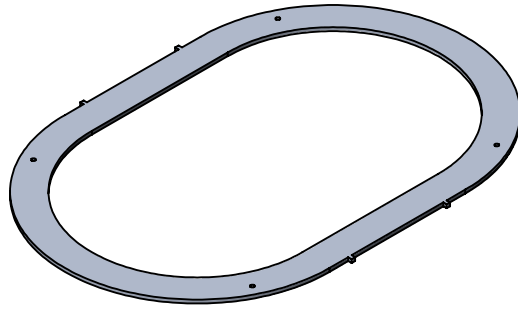

PROPRIETARY AND CONFIDENTIAL
 THE INFORMATION CONTAINED IN THIS DRAWING IS THE SOLE PROPERTY OF <INSERT COMPANY NAME HERE>. ANY REPRODUCTION IN PART OR AS A WHOLE WITHOUT THE WRITTEN PERMISSION OF <INSERT COMPANY NAME HERE> IS PROHIBITED.

		UNLESS OTHERWISE SPECIFIED:	NAME	DATE	ALUMINUM 0.125" PLATE	
		DIMENSIONS ARE IN INCHES TOLERANCES: FRACTIONAL ± ANGULAR: MACH ± BEND ± TWO PLACE DECIMAL ± THREE PLACE DECIMAL ±	DRAWN			
		INTERPRET GEOMETRIC TOLERANCING PER:	CHECKED		2400-15"-24W9-CFAHF-EMR-WET-41K	
		MATERIAL	ENG APPR.			
		FINISH	MFG APPR.		SIZE	DWG. NO.
NEXT ASSY	USED ON		Q.A.		A	REV
APPLICATION		DO NOT SCALE DRAWING	COMMENTS:		SCALE: 1:5	WEIGHT:
						SHEET 7 OF 8

5

4

3

2

1

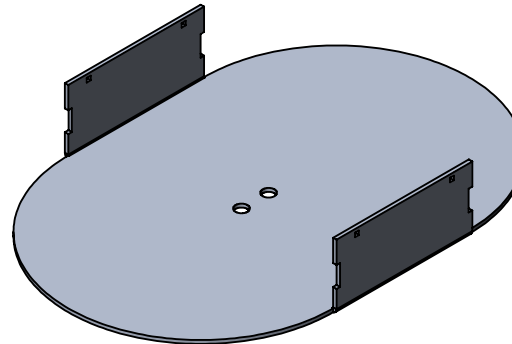
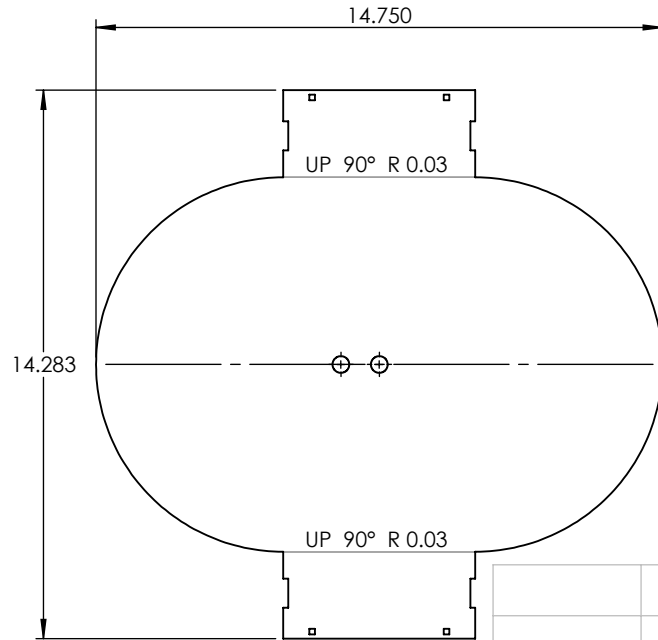
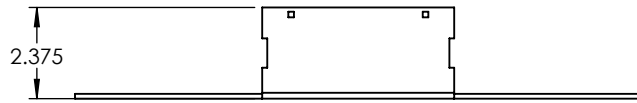
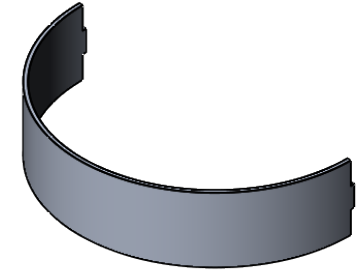
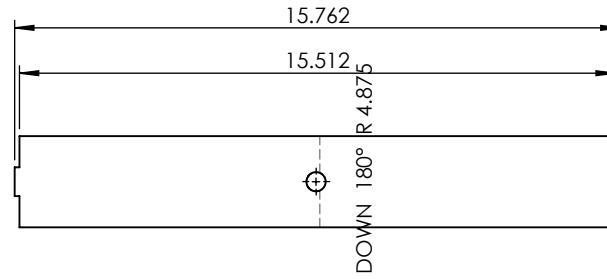
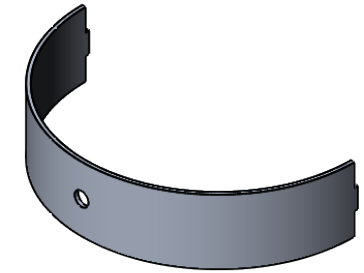
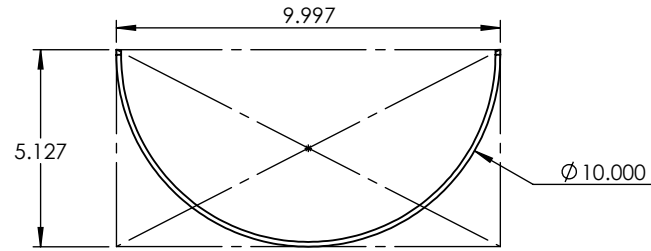

PROPRIETARY AND CONFIDENTIAL
 THE INFORMATION CONTAINED IN THIS DRAWING IS THE SOLE PROPERTY OF <INSERT COMPANY NAME HERE>. ANY REPRODUCTION IN PART OR AS A WHOLE WITHOUT THE WRITTEN PERMISSION OF <INSERT COMPANY NAME HERE> IS PROHIBITED.

		UNLESS OTHERWISE SPECIFIED:	NAME	DATE	ALUMINUM 0.125" PLATE	
		DIMENSIONS ARE IN INCHES TOLERANCES: FRACTIONAL ± ANGULAR: MACH ± BEND ± TWO PLACE DECIMAL ± THREE PLACE DECIMAL ±	DRAWN			
		INTERPRET GEOMETRIC TOLERANCING PER:	CHECKED		2400-15"-24W9-CFAHF-EMR-WET-41K	
		MATERIAL	ENG APPR.			
		FINISH	MFG APPR.		SIZE	DWG. NO.
NEXT ASSY	USED ON		Q.A.		A	REV
APPLICATION		DO NOT SCALE DRAWING	COMMENTS:		SCALE: 1:5	WEIGHT:
5	4	3	2	1	SHEET 8 OF 8	