

ITEM NO.	PART NUMBER	DESCRIPTION	QTY.	CUT
1	BX-UD-18X6-24W-MBK-WF-WET-30K-FRAME	22 GAUGE	1	
2	BX-UD-18X6-24W-MBK-WF-WET-30K-FRAME TAB	22 GAUGE	4	
3	BX-UD-18X6-24W-MBK-WF-WET-30K-BACKPLATE	22 GAUGE	1	
4	BX-UD-18X6-24W-MBK-WF-WET-30K-FIREPLATE	22 GAUGE	1	
5	BX-UD-18X6-24W-MBK-WF-WET-30K-LED BRACKET	22 GAUGE	2	
6	Alfa_LED_PN1019_SHIM PLATE	ALUMINUM 0.125" PLATE	2	
7	KTLD-25-UV-700-VDIM-LA1	DRIVER	1	
8	Alfa_LED_PN1019_RevC	LED	2	

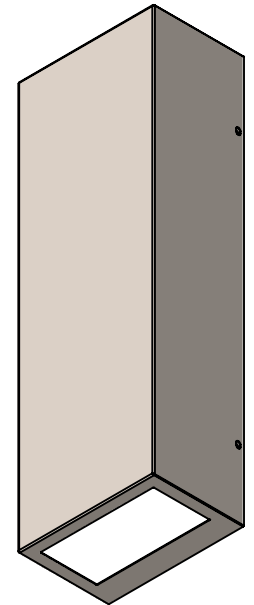
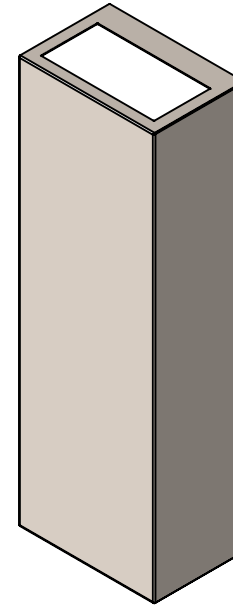
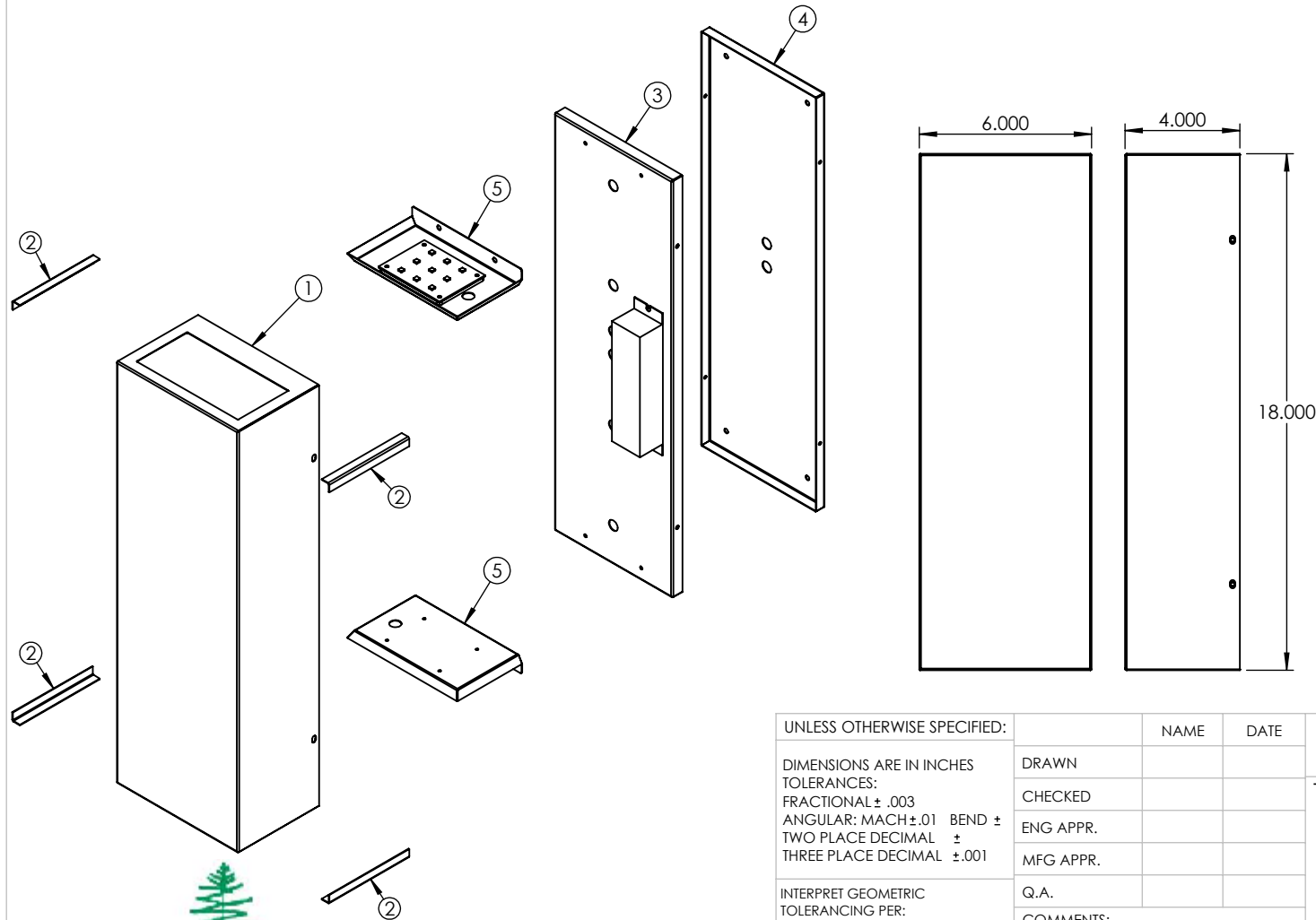

ALL BEND RADIUS .030"

UNLESS OTHERWISE SPECIFIED:

DIMENSIONS ARE IN INCHES
 TOLERANCES:
 FRACTIONAL ± .003
 ANGULAR: MACH ± .01 BEND ±
 TWO PLACE DECIMAL ±
 THREE PLACE DECIMAL ±.001

INTERPRET GEOMETRIC
 TOLERANCING PER:

MATERIAL

FINISH

APPLICATION

DO NOT SCALE DRAWING

NAME

DATE

DRAWN

CHECKED

ENG APPR.

MFG APPR.

Q.A.

COMMENTS:

TITLE:

BX-UD-18X6-24W-MBK-WF-WET-30K

SIZE DWG. NO.

A TICKET 26279

REV

SCALE: 1:6

WEIGHT:

SHEET 1 OF 7

5

4

3

2

1

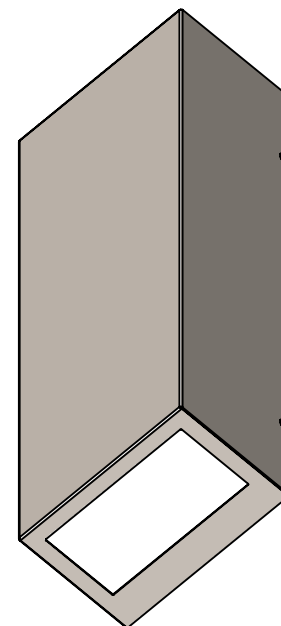
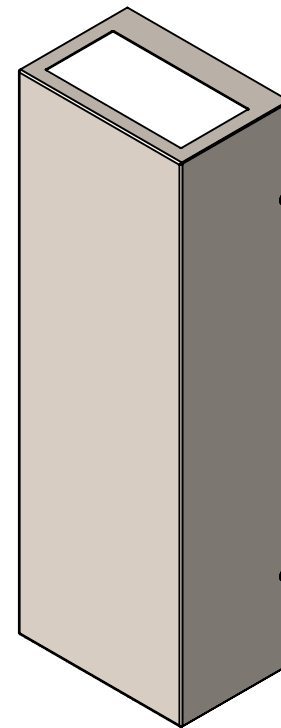
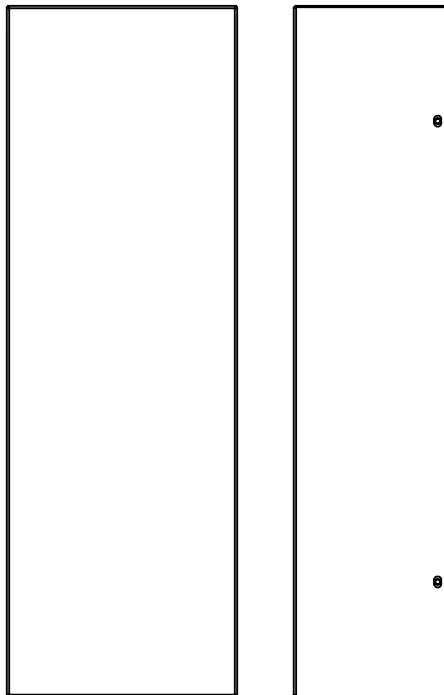
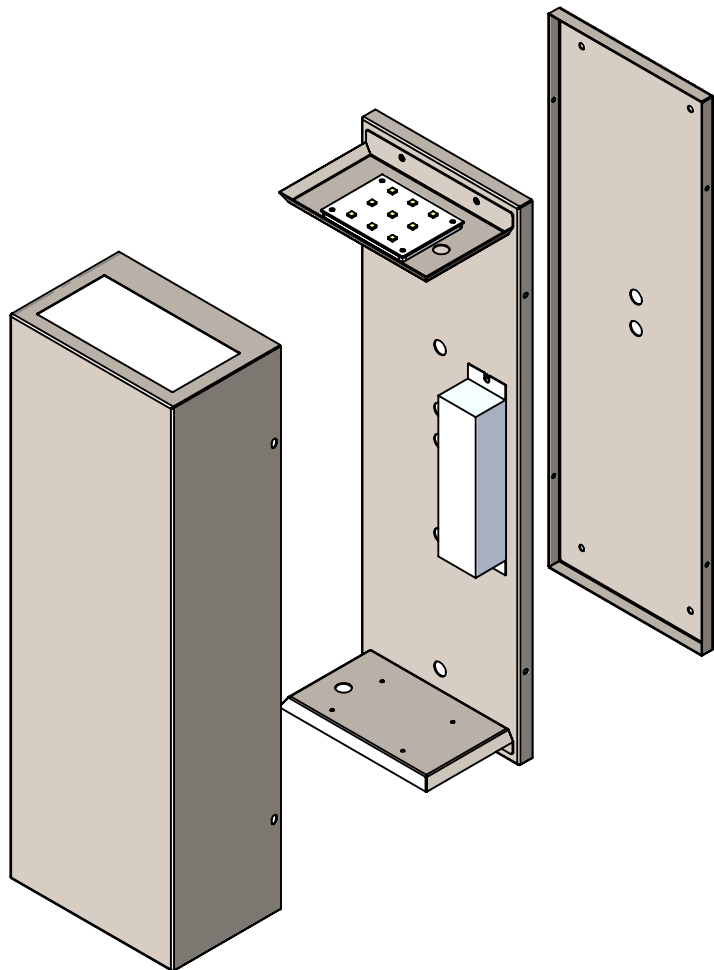

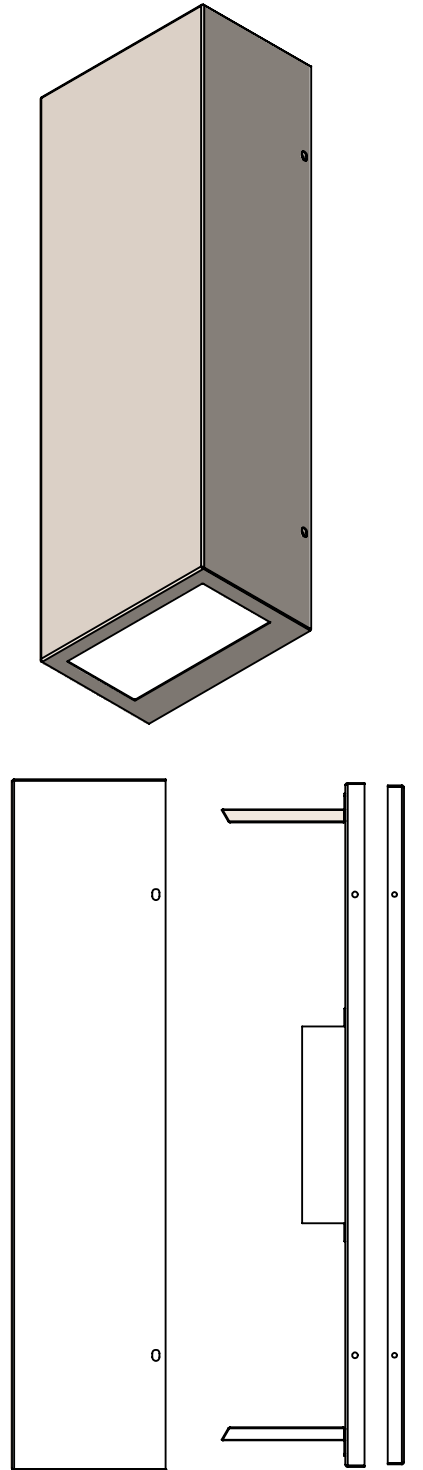
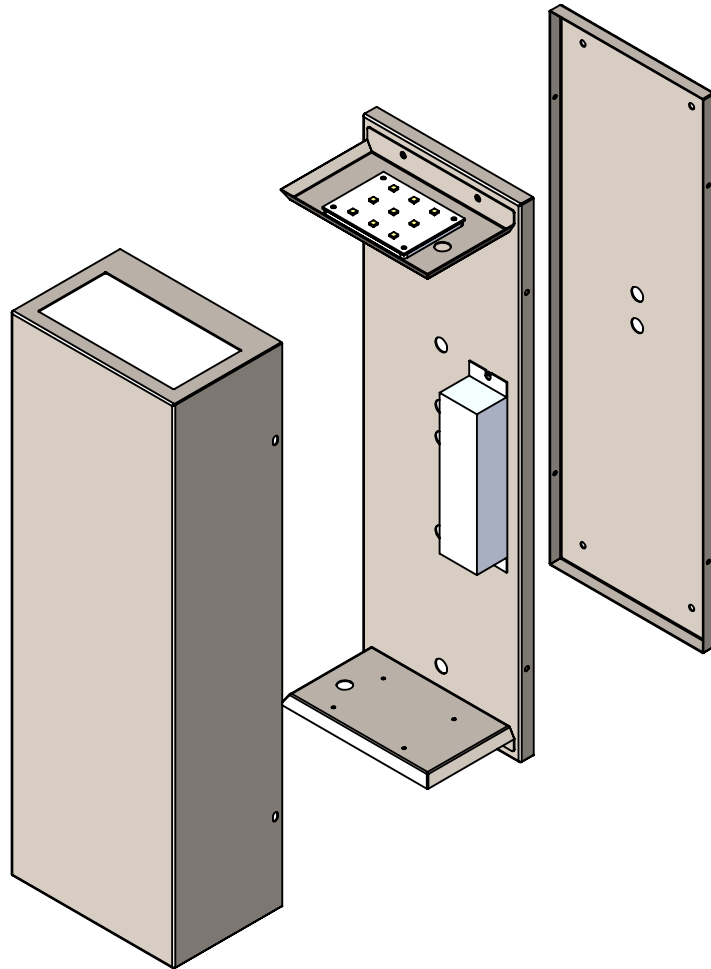
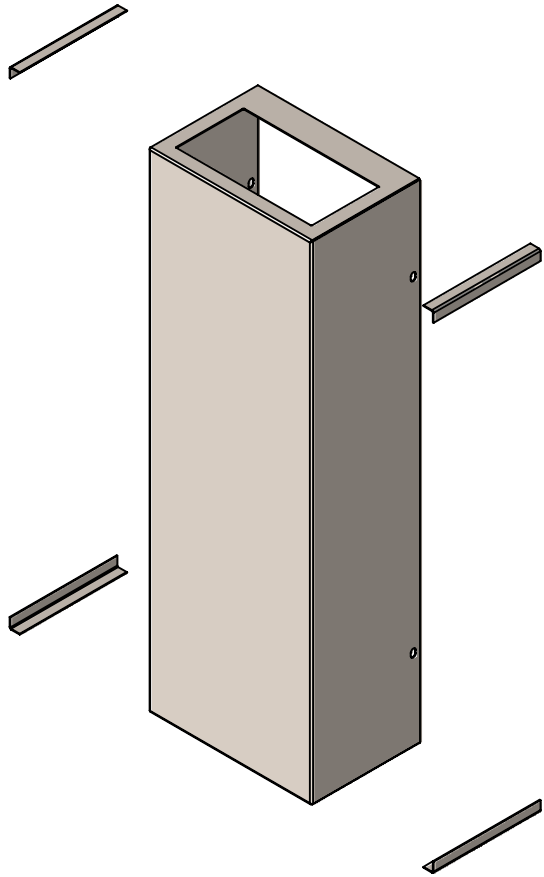

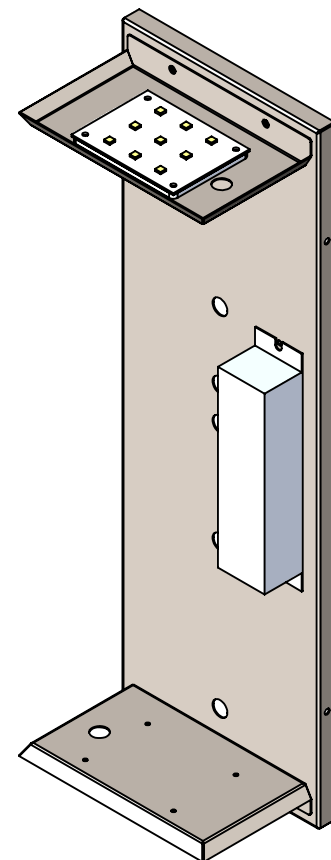
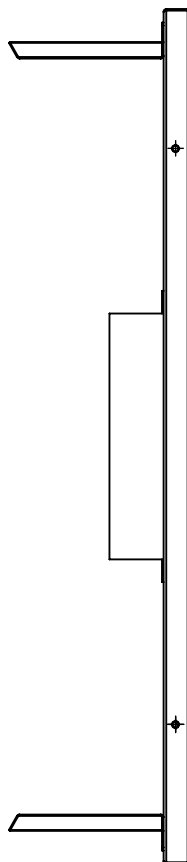
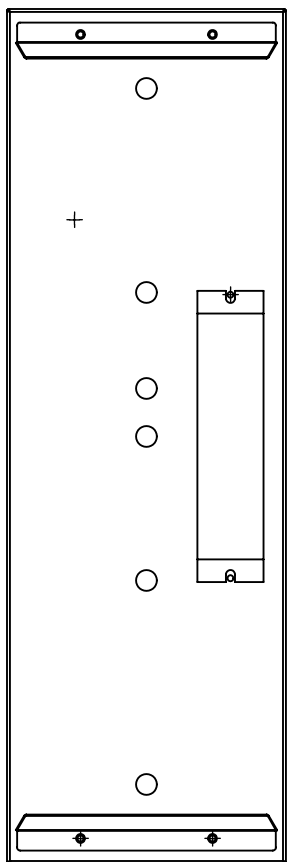
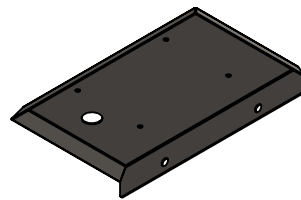
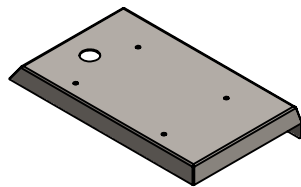
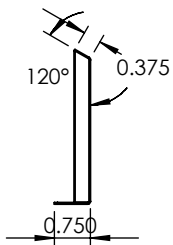
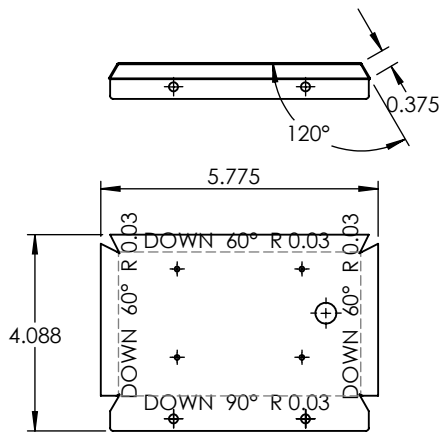

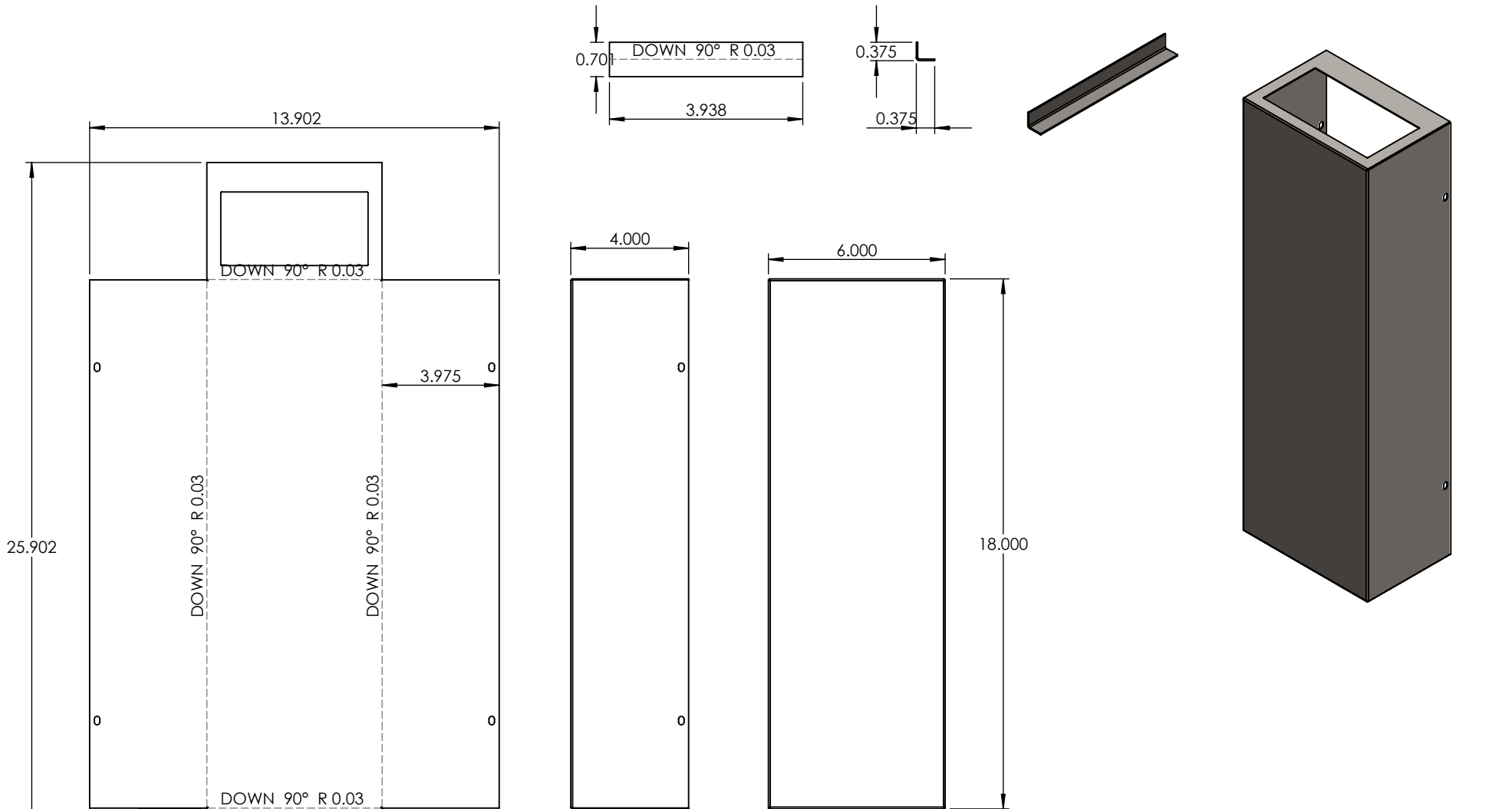

<p>PROPRIETARY AND CONFIDENTIAL THE INFORMATION CONTAINED IN THIS DRAWING IS THE SOLE PROPERTY OF <INSERT COMPANY NAME HERE>. ANY REPRODUCTION IN PART OR AS A WHOLE WITHOUT THE WRITTEN PERMISSION OF <INSERT COMPANY NAME HERE> IS PROHIBITED.</p>			UNLESS OTHERWISE SPECIFIED:		NAME	DATE	<h2>22 GAUGE</h2>		
			DIMENSIONS ARE IN INCHES TOLERANCES: FRACTIONAL ± ANGULAR: MACH ± BEND ± TWO PLACE DECIMAL ± THREE PLACE DECIMAL ±	DRAWN					TITLE:
			INTERPRET GEOMETRIC TOLERANCING PER:	CHECKED			BX-UD-18X6-24W-MBK-WF-WET-30K		
			MATERIAL	ENG APPR.					
			FINISH	MFG APPR.					
		APPLICATION	DO NOT SCALE DRAWING	Q.A.			SIZE	DWG. NO.	REV
				COMMENTS:			A		
							SCALE: 1:5	WEIGHT:	SHEET 5 OF 7

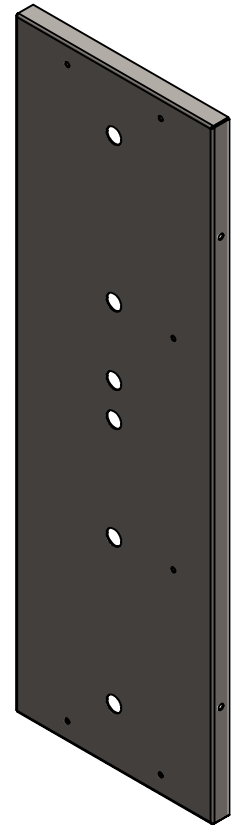
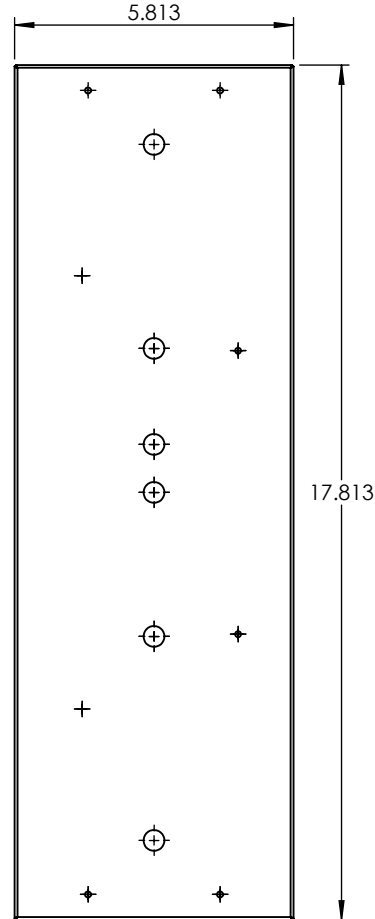
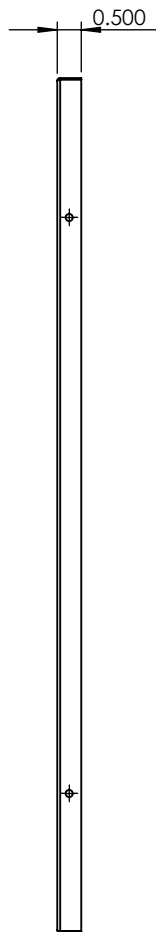
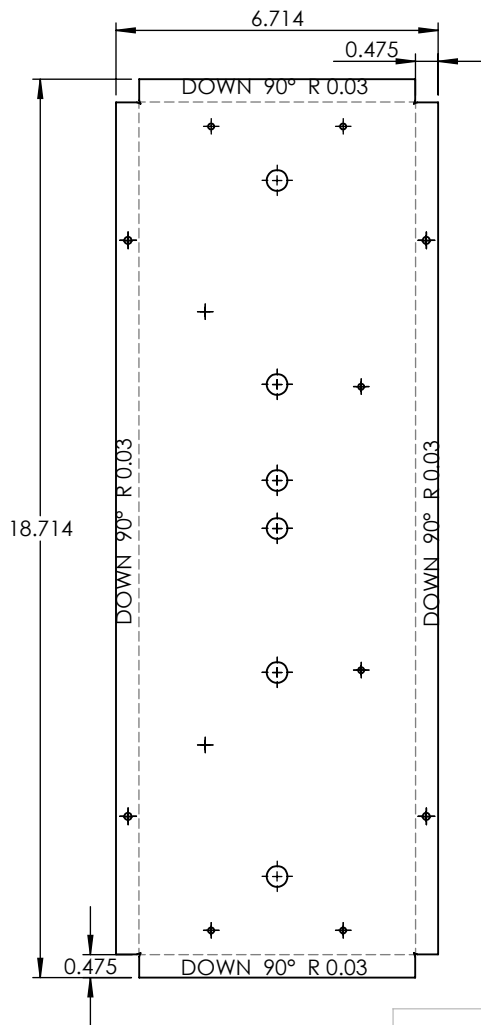

PROPRIETARY AND CONFIDENTIAL
 THE INFORMATION CONTAINED IN THIS DRAWING IS THE SOLE PROPERTY OF <INSERT COMPANY NAME HERE>. ANY REPRODUCTION IN PART OR AS A WHOLE WITHOUT THE WRITTEN PERMISSION OF <INSERT COMPANY NAME HERE> IS PROHIBITED.

		UNLESS OTHERWISE SPECIFIED:		NAME	DATE
		DIMENSIONS ARE IN INCHES	DRAWN		
		TOLERANCES:	CHECKED		
		FRACTIONAL ±	ENG APPR.		
		ANGULAR: MACH ± BEND ±	MFG APPR.		
		TWO PLACE DECIMAL ±	Q.A.		
		THREE PLACE DECIMAL ±	COMMENTS:		
		INTERPRET GEOMETRIC TOLERANCING PER:			
		MATERIAL			
NEXT ASSY	USED ON	FINISH			
APPLICATION		DO NOT SCALE DRAWING			

22 GAUGE

TITLE:
 BX-UD-18X6-24W-MBK-WF-WET-30K

SIZE	DWG. NO.	REV
A		
SCALE: 1:4	WEIGHT:	SHEET 6 OF 7

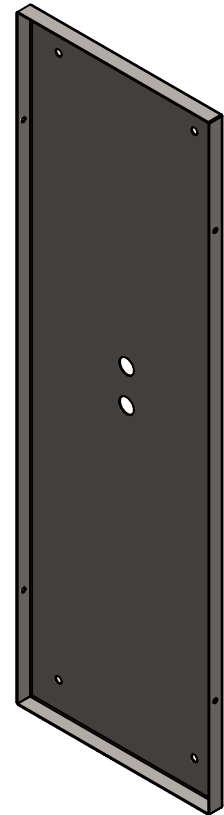
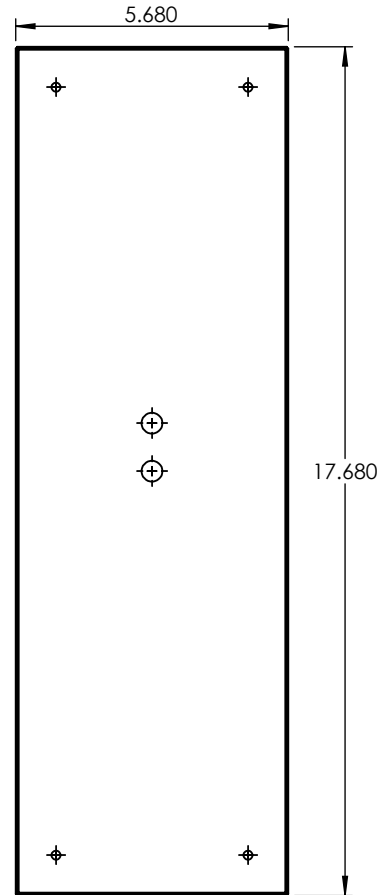
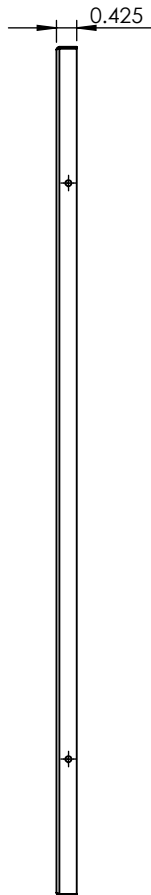
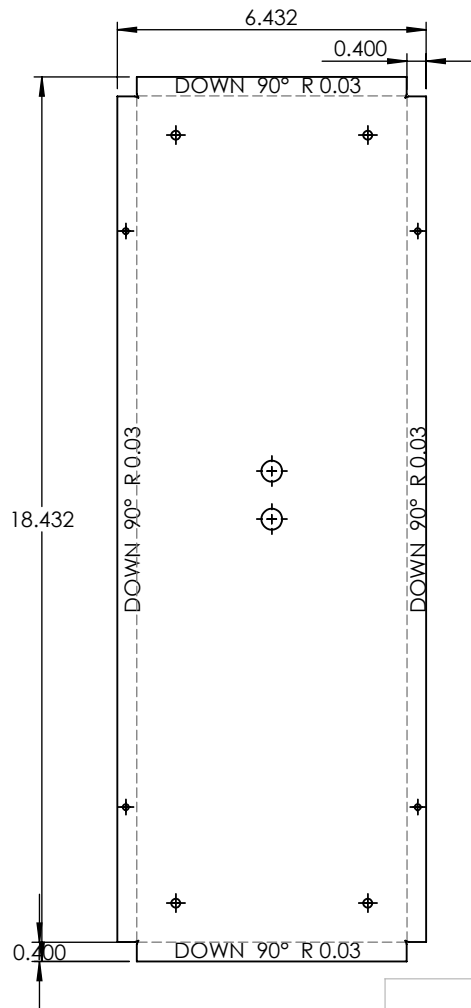

PROPRIETARY AND CONFIDENTIAL
 THE INFORMATION CONTAINED IN THIS DRAWING IS THE SOLE PROPERTY OF <INSERT COMPANY NAME HERE>. ANY REPRODUCTION IN PART OR AS A WHOLE WITHOUT THE WRITTEN PERMISSION OF <INSERT COMPANY NAME HERE> IS PROHIBITED.

		UNLESS OTHERWISE SPECIFIED:		NAME	DATE
		DIMENSIONS ARE IN INCHES TOLERANCES: FRACTIONAL ± ANGULAR: MACH ± BEND ± TWO PLACE DECIMAL ± THREE PLACE DECIMAL ±	DRAWN		
		INTERPRET GEOMETRIC TOLERANCING PER:	CHECKED		
		MATERIAL	ENG APPR.		
		FINISH	MFG APPR.		
			Q.A.		
			COMMENTS:		
NEXT ASSY	USED ON				
APPLICATION		DO NOT SCALE DRAWING			

22 GAUGE

TITLE:
 BX-UD-18X6-24W-MBK-WF-WET-30K

SIZE	DWG. NO.	REV
A		
SCALE: 1:4	WEIGHT:	SHEET 7 OF 7