

ALL BEND RADIUS .030"

APPLICATION

DO NOT SCALE DRAWING

UNLESS OTHERWISE SPECIFIED:

DIMENSIONS ARE IN INCHES  
 TOLERANCES:  
 FRACTIONAL ± .003  
 ANGULAR: MACH ± .01 BEND ±  
 TWO PLACE DECIMAL ±  
 THREE PLACE DECIMAL ±.001

INTERPRET GEOMETRIC  
 TOLERANCING PER:

MATERIAL

FINISH

NAME

DATE

DRAWN

CHECKED

ENG APPR.

MFG APPR.

Q.A.

COMMENTS:

TITLE:

LDSCP15"-PST-46L-2ARM-MBK-A-40K-10YR

SIZE DWG. NO.

**A** TICKET 26322

REV

SCALE: 1:8

WEIGHT:

SHEET 1 OF 10

5

4

3

2

1

| ITEM NO. | PART NUMBER   | DESCRIPTION               | QTY. | CUT |
|----------|---|---------------------------|------|-----|
| 1        | LDSCP15"-PST-46L-2ARM-MBK-A-40K-10YR- SPUN TOP HEAD       | SPUN ALUMINUM 0.080"      | 1    |     |
| 2        | LDSCP15"-PST-46L-2ARM-MBK-A-40K-10YR- SPUN HEAD           | SPUN ALUMINUM 0.080"      | 1    |     |
| 3        | LDSCP15"-PST-46L-2ARM-MBK-A-40K-10YR-SPUN DOOR            | SPUN ALUMINUM 0.0635"     | 1    |     |
| 4        | LDSCP15"-PST-46L-2ARM-MBK-A-40K-10YR-SPUN BRACKET         | SPUN ALUMINUM 0.0635"     | 1    |     |
| 5        | LDSCP15"-PST-46L-2ARM-MBK-A-40K-10YR- FRAME TUBE          | 3/4" X 1/2" ALUMINUM TUBE | 2    |     |
| 6        | LDSCP15"-PST-46L-2ARM-MBK-A-40K-10YR-CYLINDER PLATE COVER | ALUMINUM 0.500" PLATE     | 2    |     |
| 7        | LDSCP15"-PST-46L-2ARM-MBK-A-40K-10YR-TUBE BRACKET         | ALUMINUM 0.125" PLATE     | 2    |     |
| 8        | LDSCP15"-PST-46L-2ARM-MBK-A-40K-10YR-CYLINDER PLATE       | ALUMINUM 0.250" PLATE     | 1    |     |
| 9        | LDSCP15"-PST-46L-2ARM-MBK-A-40K-10YR-BRACKET              | ALUMINUM 0.0635"          | 2    |     |
| 10       | LDSCP15"-PST-46L-2ARM-MBK-A-40K-10YR-DRIVER BRACKET       | ALUMINUM 0.0635"          | 1    |     |
| 11       | LDSCP15"-PST-46L-2ARM-MBK-A-40K-10YR-CYLINDER POST FITTER | 3-1/2" ALUMINUM TUBE POST | 1    |     |
| 12       | Altal_LED_PN1019_SHIM PLATE                               | ALUMINUM 0.125" PLATE     | 4    |     |
| 13       | LDSCP15"-PST-46L-2ARM-MBK-A-40K-10YR-LENS                 | ACRYLIC                   | 1    |     |
| 14       | KTLD-25-UV-700-VDIM-LA1                                   | DRIVER                    | 2    |     |
| 15       | Altal_LED_PN1019_RevC                                     | LED                       | 4    |     |

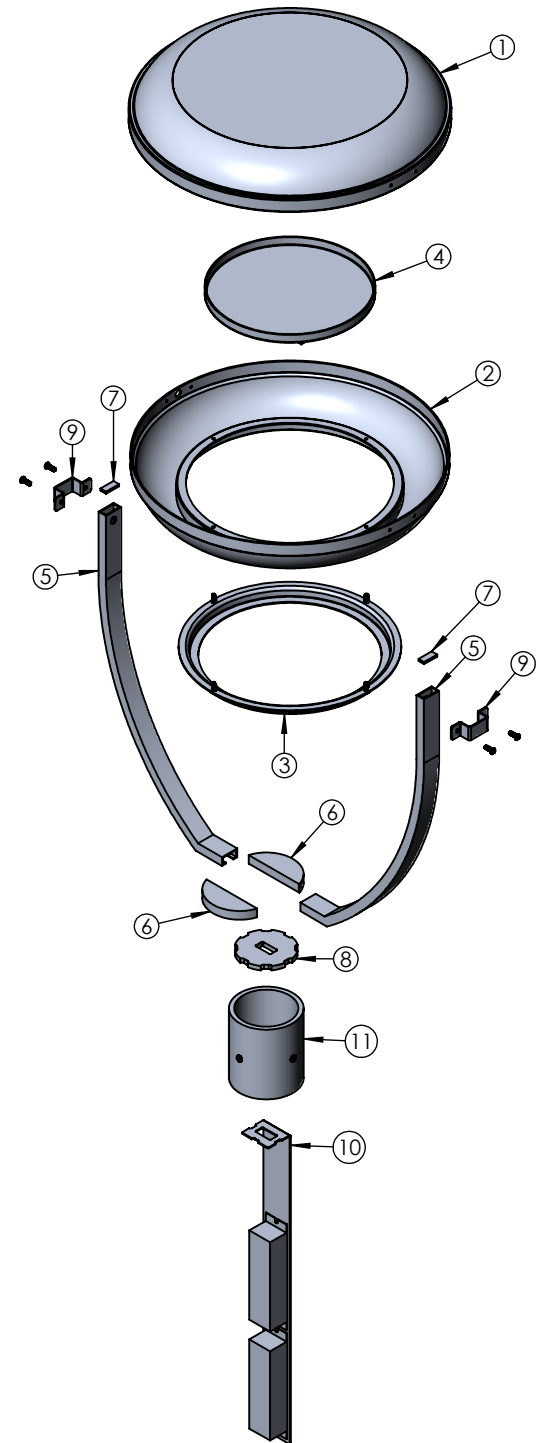

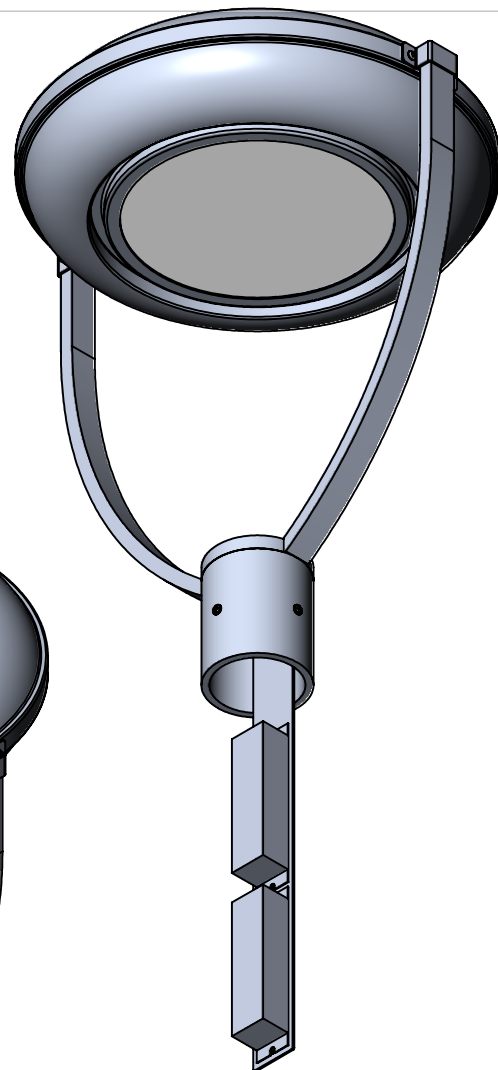
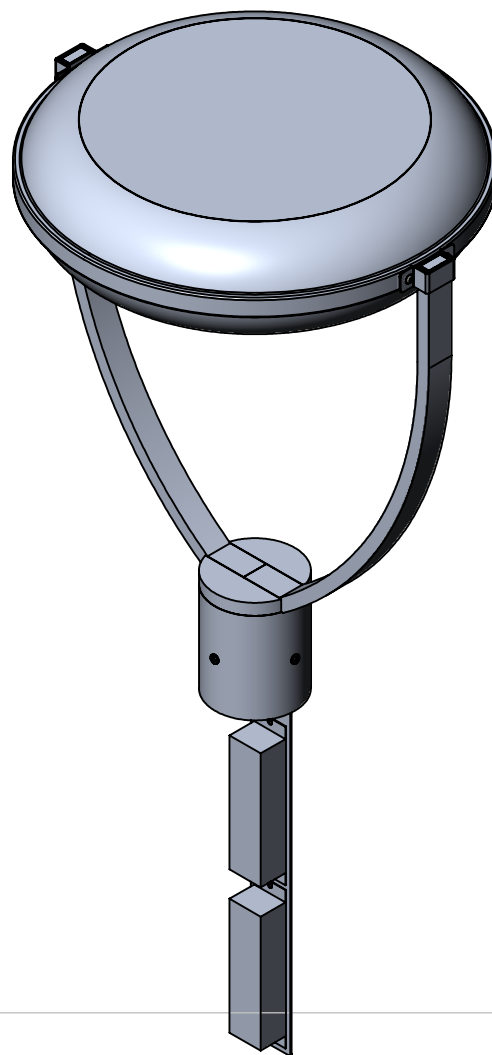
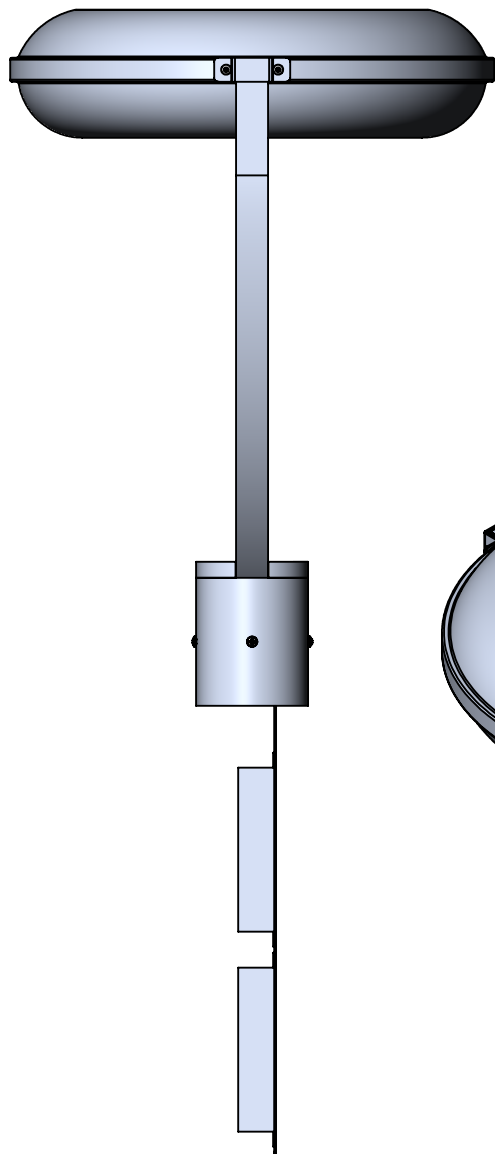
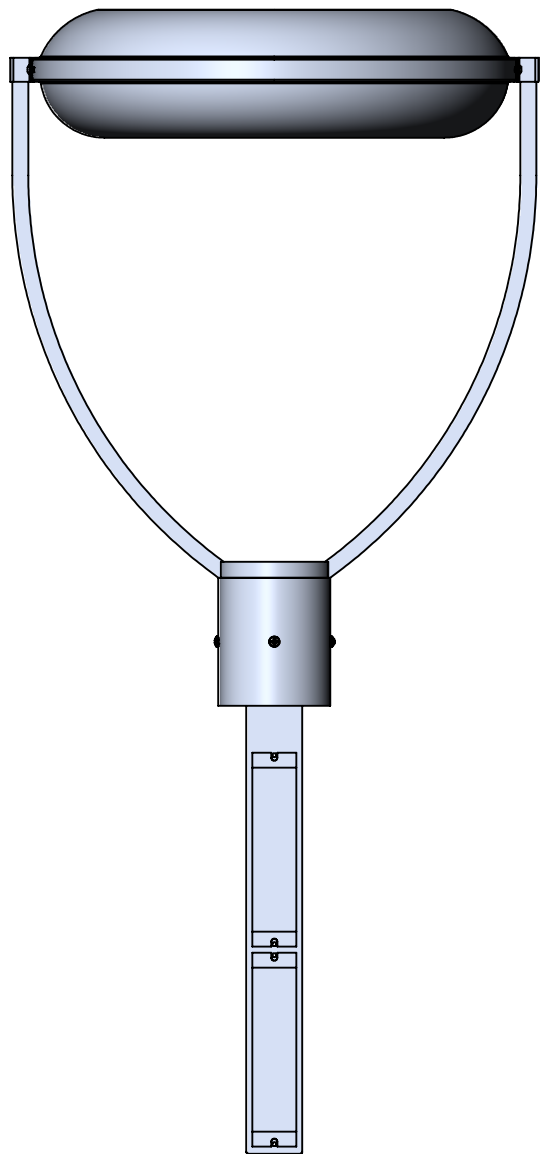

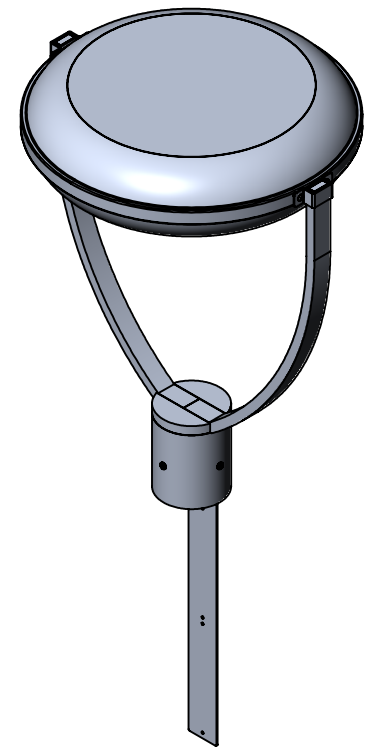
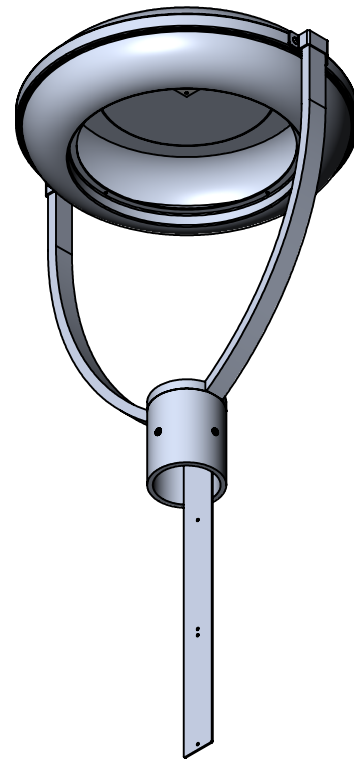
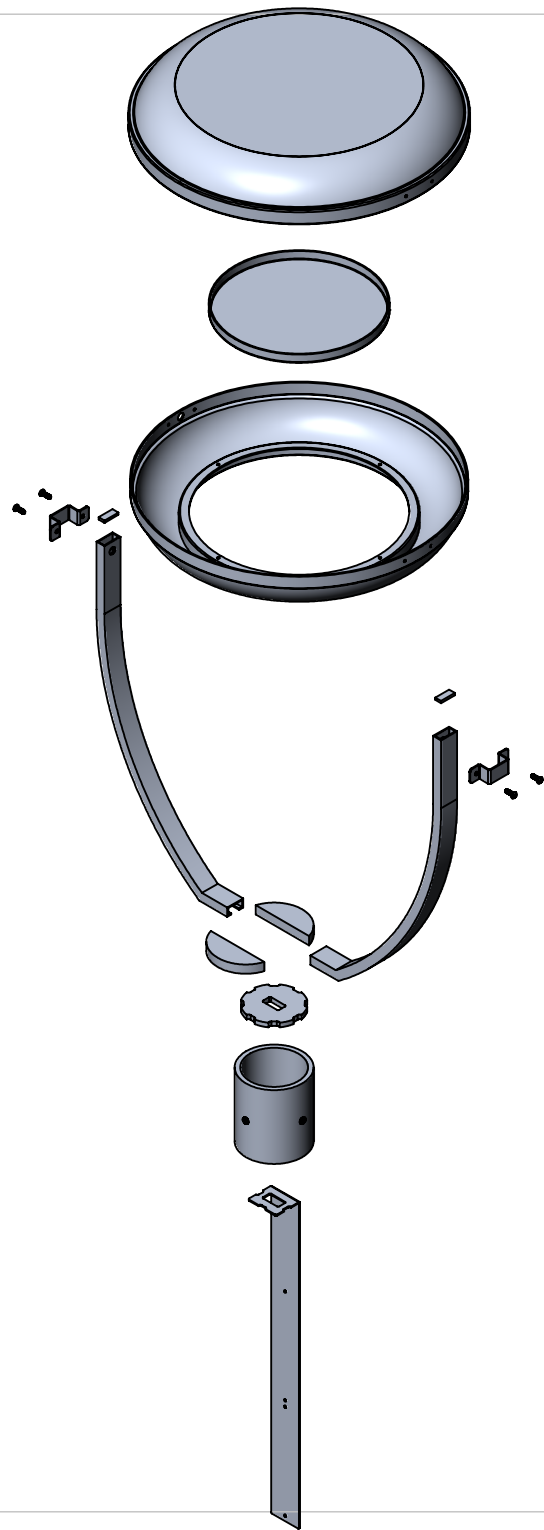

| ITEM NO. | PART NUMBER   | DESCRIPTION          | QTY. |
|----------|---|----------------------|------|
| 1        | LDSCP15"-PST-46L-2ARM-MBK-A-40K-10YR- SPUN TOP HEAD | SPUN ALUMINUM 0.080" | 1    |

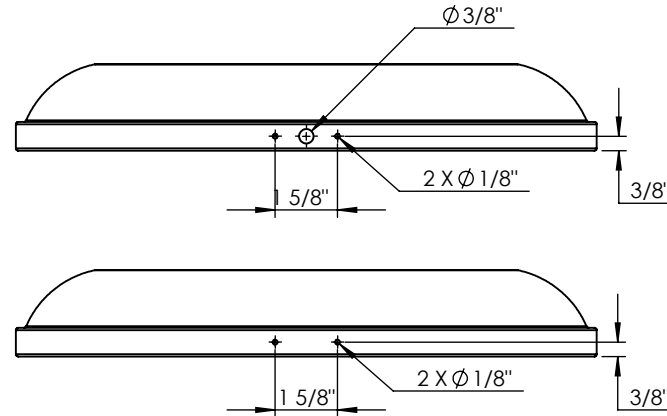
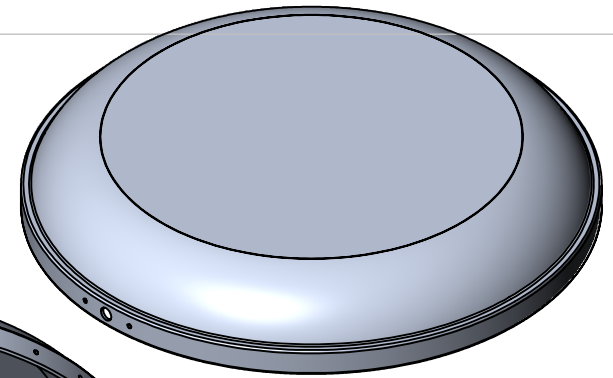
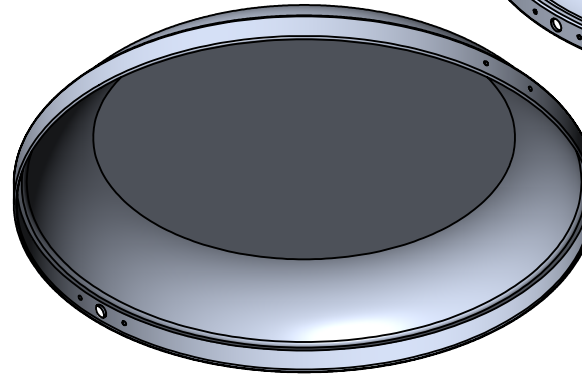
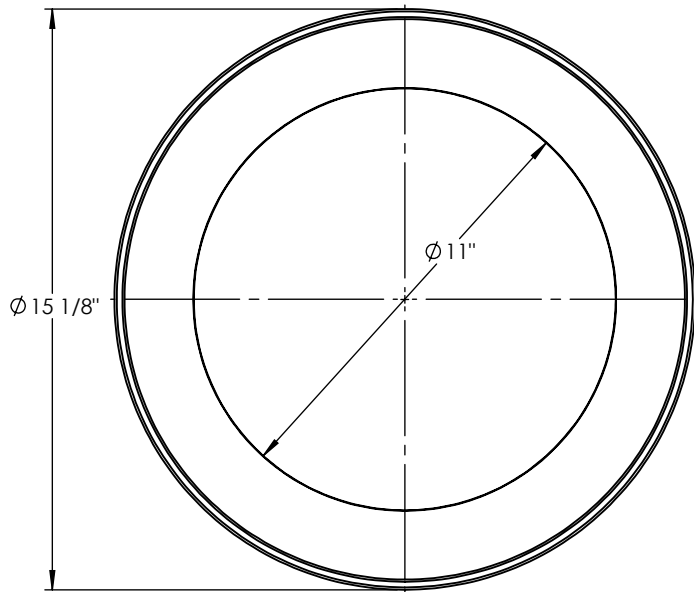
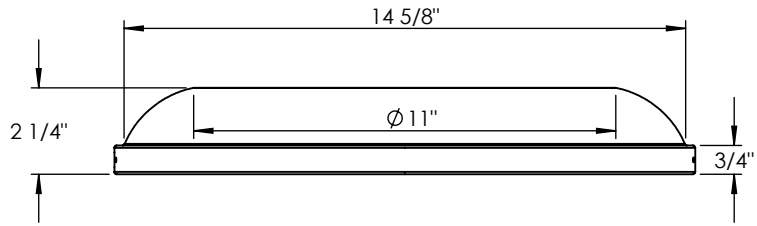

**PROPRIETARY AND CONFIDENTIAL**  
 THE INFORMATION CONTAINED IN THIS DRAWING IS THE SOLE PROPERTY OF <INSERT COMPANY NAME HERE>. ANY REPRODUCTION IN PART OR AS A WHOLE WITHOUT THE WRITTEN PERMISSION OF <INSERT COMPANY NAME HERE> IS PROHIBITED.

| UNLESS OTHERWISE SPECIFIED:          |         | NAME      | DATE |
|--------------------------------------|---------|-----------|------|
| DIMENSIONS ARE IN INCHES             |         | DRAWN     |      |
| TOLERANCES:                          |         | CHECKED   |      |
| FRACTIONAL ±                         |         | ENG APPR. |      |
| ANGULAR: MACH ± BEND ±               |         | MFG APPR. |      |
| TWO PLACE DECIMAL ±                  |         | Q.A.      |      |
| THREE PLACE DECIMAL ±                |         | COMMENTS: |      |
| INTERPRET GEOMETRIC TOLERANCING PER: |         |           |      |
| MATERIAL                             |         |           |      |
| FINISH                               |         |           |      |
| NEXT ASSY                            | USED ON |           |      |
| APPLICATION                          |         |           |      |
| DO NOT SCALE DRAWING                 |         |           |      |

SPUN ALUMINUM 0.080"

TITLE:

LDSCP15"-PST-46L-2ARM-MBK-A-40K-10YR

|          |          |     |
|----------|----------|-----|
| SIZE     | DWG. NO. | REV |
| <b>A</b> |          |     |

|            |         |               |
|------------|---------|---------------|
| SCALE: 1:5 | WEIGHT: | SHEET 5 OF 10 |
|------------|---------|---------------|

| ITEM NO. | PART NUMBER                                     | DESCRIPTION          | QTY. |
|----------|---|----------------------|------|
| 1        | LDSCP15"-PST-46L-2ARM-MBK-A-40K-10YR- SPUN HEAD | SPUN ALUMINUM 0.080" | 1    |

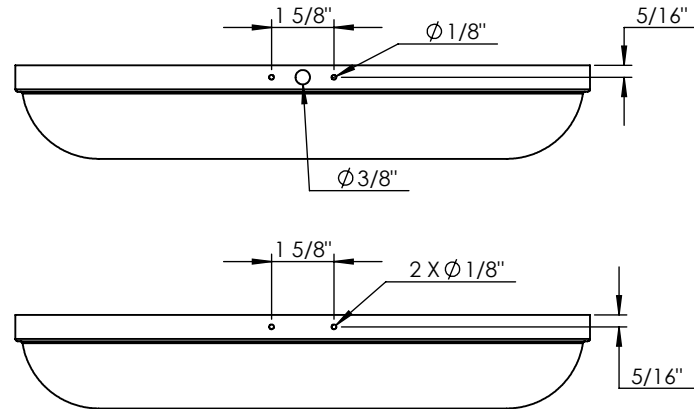
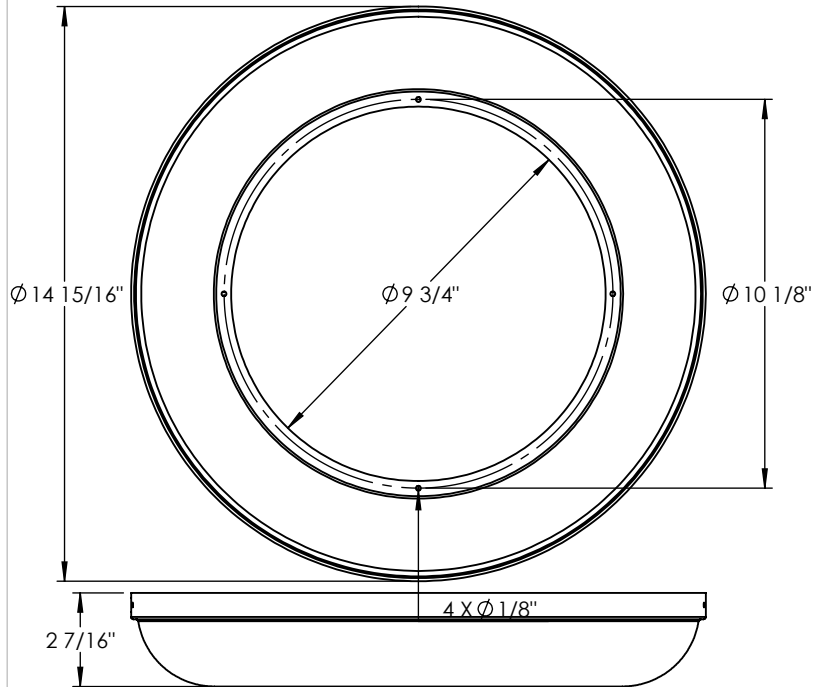
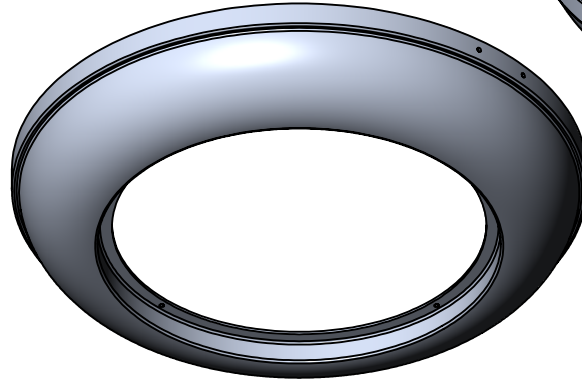
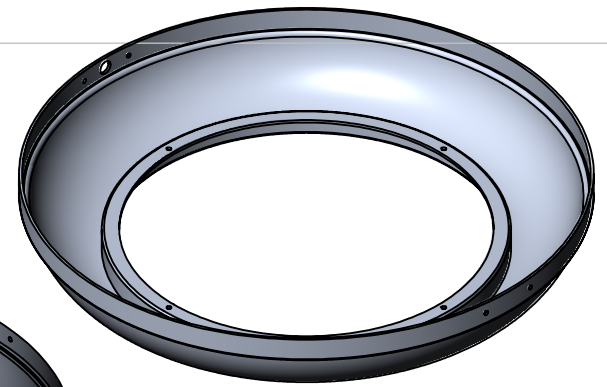
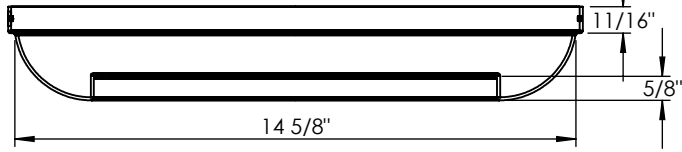

**PROPRIETARY AND CONFIDENTIAL**  
 THE INFORMATION CONTAINED IN THIS DRAWING IS THE SOLE PROPERTY OF <INSERT COMPANY NAME HERE>. ANY REPRODUCTION IN PART OR AS A WHOLE WITHOUT THE WRITTEN PERMISSION OF <INSERT COMPANY NAME HERE> IS PROHIBITED.

|             |         |                                |           |      |                                      |               |
|-------------|---------|--------------------------------|-----------|------|--------------------------------------|---------------|
|             |         | UNLESS OTHERWISE SPECIFIED:    | NAME      | DATE | SPUN ALUMINUM 0.080"                 |               |
|             |         | DIMENSIONS ARE IN INCHES       | DRAWN     |      | TITLE:                               |               |
|             |         | TOLERANCES:                    | CHECKED   |      | LDSCP15"-PST-46L-2ARM-MBK-A-40K-10YR |               |
|             |         | FRACTIONAL $\pm$               | ENG APPR. |      | SIZE                                 | DWG. NO.      |
|             |         | ANGULAR: MACH $\pm$ BEND $\pm$ | MFG APPR. |      | <b>A</b>                             | REV           |
|             |         | TWO PLACE DECIMAL $\pm$        | Q.A.      |      | SCALE: 1:5                           | WEIGHT:       |
|             |         | THREE PLACE DECIMAL $\pm$      | COMMENTS: |      |                                      | SHEET 6 OF 10 |
| NEXT ASSY   | USED ON | MATERIAL                       |           |      |                                      |               |
| APPLICATION |         | FINISH                         |           |      |                                      |               |
|             |         | DO NOT SCALE DRAWING           |           |      |                                      |               |

5

4

3

2

1

| ITEM NO. | PART NUMBER                                       | DESCRIPTION           | QTY. |
|----------|---|-----------------------|------|
| 1        | LDSCP15"-PST-46L-2ARM-MBK-A-40K-10YR-SPUN BRACKET | SPUN ALUMINUM 0.0635" | 1    |

| ITEM NO. | PART NUMBER                                    | DESCRIPTION           | QTY. |
|----------|--|-----------------------|------|
| 1        | LDSCP15"-PST-46L-2ARM-MBK-A-40K-10YR-SPUN DOOR | SPUN ALUMINUM 0.0635" | 1    |

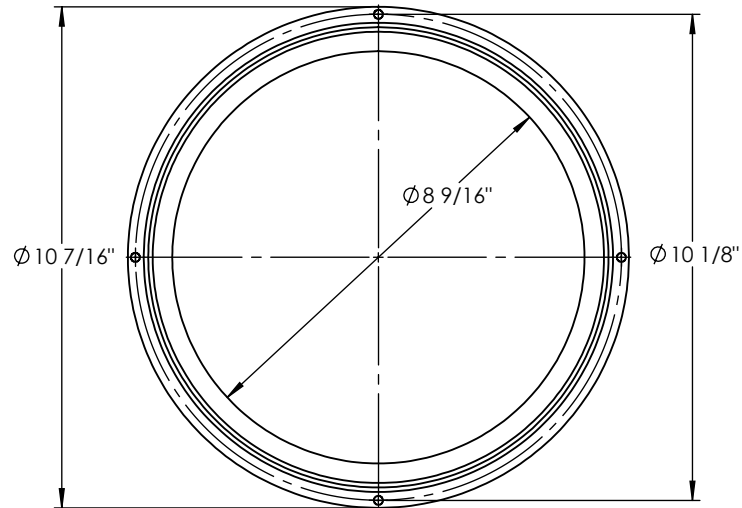
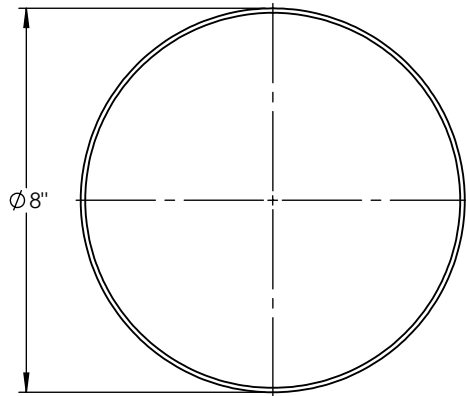
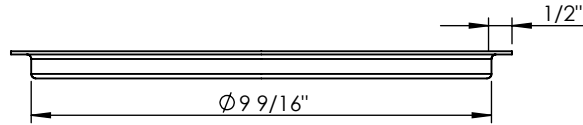
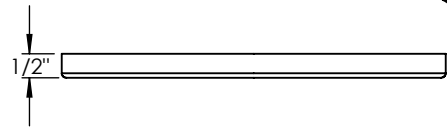
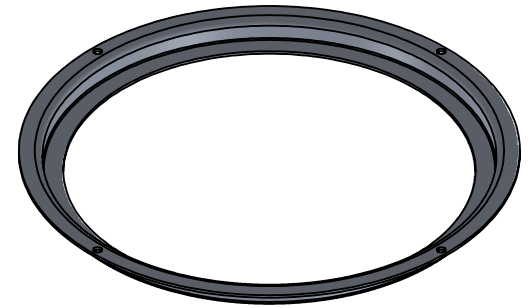
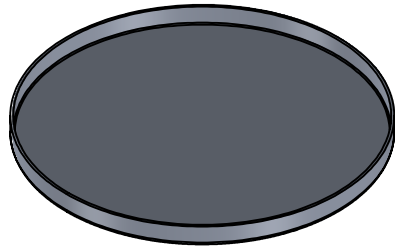

**PROPRIETARY AND CONFIDENTIAL**  
 THE INFORMATION CONTAINED IN THIS DRAWING IS THE SOLE PROPERTY OF <INSERT COMPANY NAME HERE>. ANY REPRODUCTION IN PART OR AS A WHOLE WITHOUT THE WRITTEN PERMISSION OF <INSERT COMPANY NAME HERE> IS PROHIBITED.

|             |         |                                      |           |      |                                      |  |
|-------------|---------|--------------------------------------|-----------|------|--------------------------------------|--|
|             |         | UNLESS OTHERWISE SPECIFIED:          | NAME      | DATE | SPUN ALUMINUM 0.0635"                |  |
|             |         | DIMENSIONS ARE IN INCHES             | DRAWN     |      | TITLE:                               |  |
|             |         | TOLERANCES:                          | CHECKED   |      | LDSCP15"-PST-46L-2ARM-MBK-A-40K-10YR |  |
|             |         | FRACTIONAL ±                         | ENG APPR. |      | SIZE DWG. NO. REV                    |  |
|             |         | ANGULAR: MACH ± BEND ±               | MFG APPR. |      | A                                    |  |
|             |         | TWO PLACE DECIMAL ±                  | Q.A.      |      | SCALE: 1:4 WEIGHT: SHEET 7 OF 10     |  |
|             |         | THREE PLACE DECIMAL ±                | COMMENTS: |      |                                      |  |
|             |         | INTERPRET GEOMETRIC TOLERANCING PER: |           |      |                                      |  |
|             |         | MATERIAL                             |           |      |                                      |  |
| NEXT ASSY   | USED ON | FINISH                               |           |      |                                      |  |
| APPLICATION |         | DO NOT SCALE DRAWING                 |           |      |                                      |  |

5

4

3

2

1

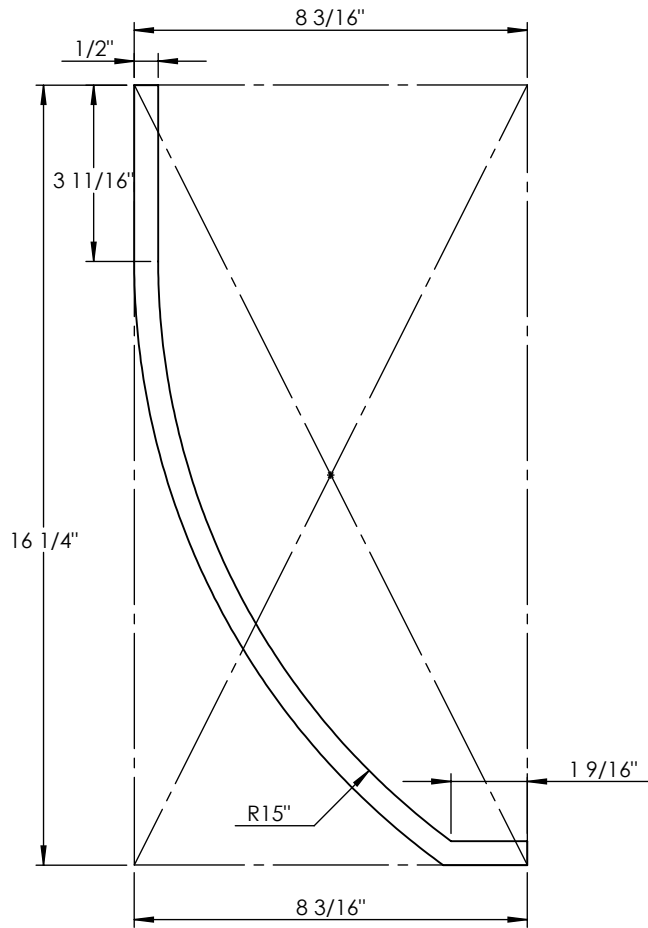

**1" X 1/2" TUBE WITH LENGTH OF 18-1/8"**

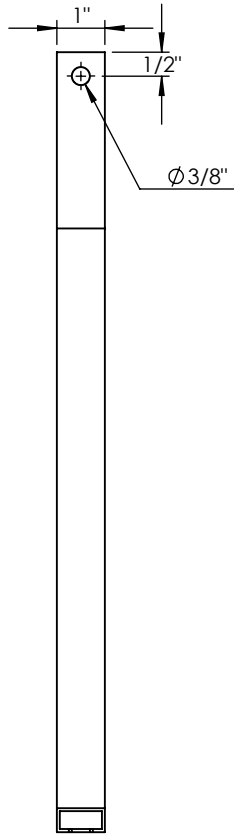

**1" X 1/2" TUBE**

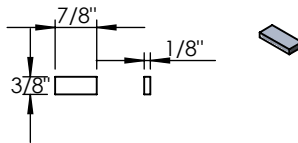
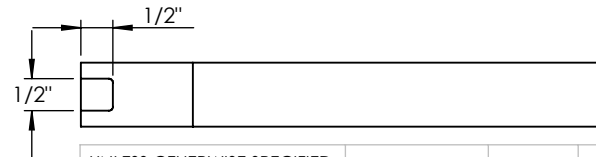
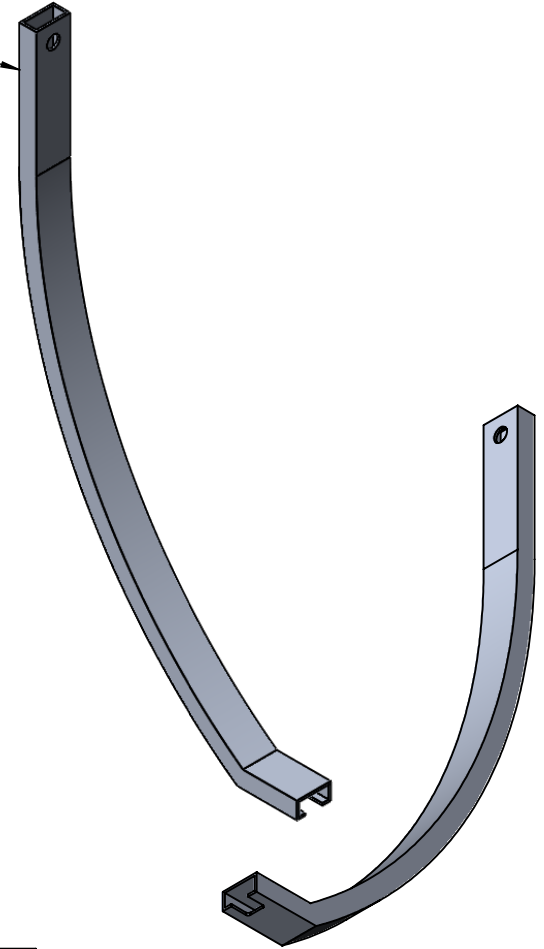

|                             |      |      |                                  |
|-----------------------------|------|------|----------------------------------|
| UNLESS OTHERWISE SPECIFIED: | NAME | DATE | <b>3/4" X 1/2" ALUMINUM TUBE</b> |
|-----------------------------|------|------|----------------------------------|

DIMENSIONS ARE IN INCHES  
 TOLERANCES:  
 FRACTIONAL ±  
 ANGULAR: MACH ± BEND ±  
 TWO PLACE DECIMAL ±  
 THREE PLACE DECIMAL ±

DRAWN  
 CHECKED  
 ENG APPR.  
 MFG APPR.

NAME  
 DATE

TITLE:

**LDSCP15"-PST-46L-2ARM-MBK-A-40K-10YR**

INTERPRET GEOMETRIC TOLERANCING PER:

Q.A.  
 COMMENTS:

MATERIAL

FINISH

SIZE DWG. NO. REV

**A**

**PROPRIETARY AND CONFIDENTIAL**  
 THE INFORMATION CONTAINED IN THIS DRAWING IS THE SOLE PROPERTY OF <INSERT COMPANY NAME HERE>. ANY REPRODUCTION IN PART OR AS A WHOLE WITHOUT THE WRITTEN PERMISSION OF <INSERT COMPANY NAME HERE> IS PROHIBITED.

|           |         |             |                      |
|-----------|---------|-------------|----------------------|
| NEXT ASSY | USED ON | APPLICATION | DO NOT SCALE DRAWING |
|-----------|---------|-------------|----------------------|

SCALE: 1:4 WEIGHT: SHEET 8 OF 10



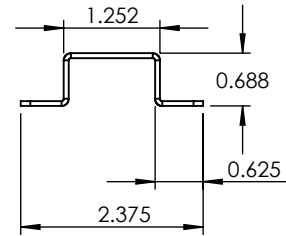
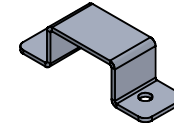
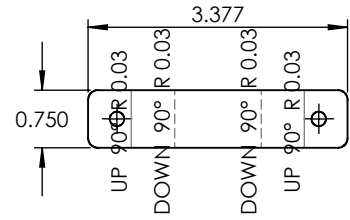
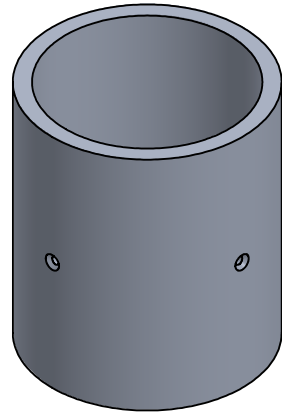
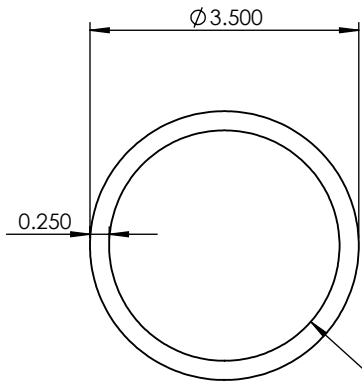

INSIDE DIMENSION MOD FOR 3" TUBE CLEARANCE

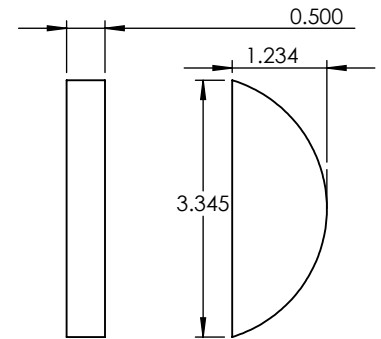
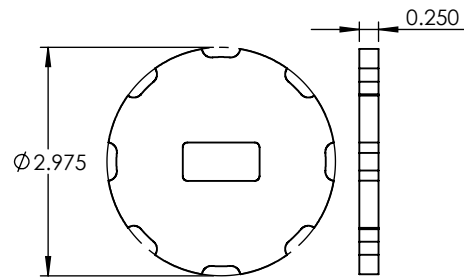
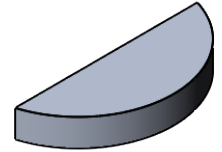
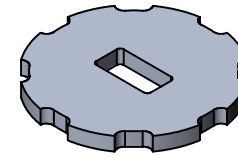
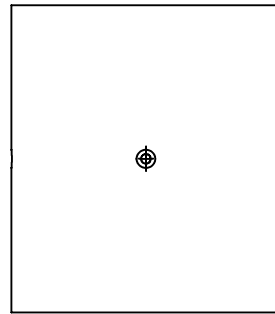
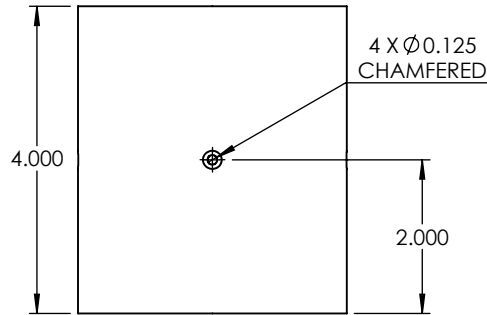

**PROPRIETARY AND CONFIDENTIAL**  
 THE INFORMATION CONTAINED IN THIS DRAWING IS THE SOLE PROPERTY OF <INSERT COMPANY NAME HERE>. ANY REPRODUCTION IN PART OR AS A WHOLE WITHOUT THE WRITTEN PERMISSION OF <INSERT COMPANY NAME HERE> IS PROHIBITED.

|             |         |                                      |           |      |      |
|-------------|---------|--------------------------------------|-----------|------|------|
|             |         | UNLESS OTHERWISE SPECIFIED:          |           | NAME | DATE |
|             |         | DIMENSIONS ARE IN INCHES             | DRAWN     |      |      |
|             |         | TOLERANCES:                          | CHECKED   |      |      |
|             |         | FRACTIONAL ±                         | ENG APPR. |      |      |
|             |         | ANGULAR: MACH ± BEND ±               | MFG APPR. |      |      |
|             |         | TWO PLACE DECIMAL ±                  | Q.A.      |      |      |
|             |         | THREE PLACE DECIMAL ±                | COMMENTS: |      |      |
|             |         | INTERPRET GEOMETRIC TOLERANCING PER: |           |      |      |
|             |         | MATERIAL                             |           |      |      |
|             |         | FINISH                               |           |      |      |
| NEXT ASSY   | USED ON |                                      |           |      |      |
| APPLICATION |         | DO NOT SCALE DRAWING                 |           |      |      |

3-1/2" ALUMINUM TUBE POST

TITLE:  
 LDSCP15"-PST-46L-2ARM-MBK-A-40K-10YR

SIZE DWG. NO. REV  
**A**

SCALE: 1:2.5 WEIGHT: SHEET 9 OF 10

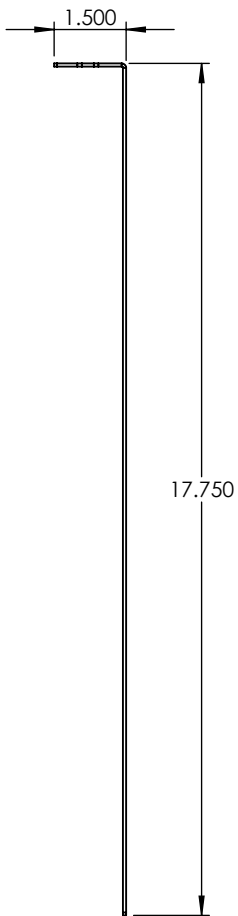
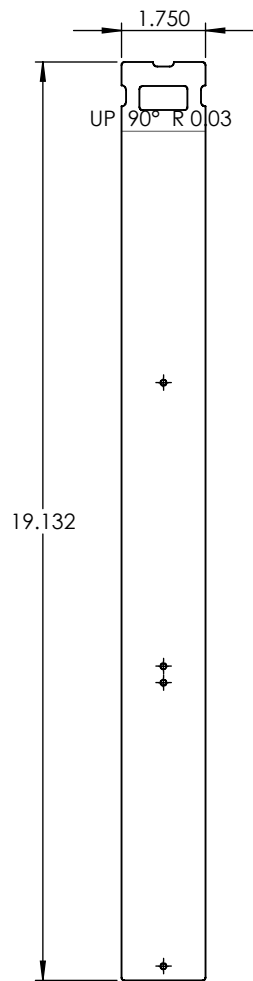

**PROPRIETARY AND CONFIDENTIAL**  
 THE INFORMATION CONTAINED IN THIS DRAWING IS THE SOLE PROPERTY OF <INSERT COMPANY NAME HERE>. ANY REPRODUCTION IN PART OR AS A WHOLE WITHOUT THE WRITTEN PERMISSION OF <INSERT COMPANY NAME HERE> IS PROHIBITED.

|  |             |                                      |           |      |                                      |  |
|--|-------------|--------------------------------------|-----------|------|--------------------------------------|--|
|  |             | UNLESS OTHERWISE SPECIFIED:          | NAME      | DATE | ALUMINUM 0.0635"                     |  |
|  |             | DIMENSIONS ARE IN INCHES             | DRAWN     |      | TITLE:                               |  |
|  |             | TOLERANCES:                          | CHECKED   |      | LDSCP15"-PST-46L-2ARM-MBK-A-40K-10YR |  |
|  |             | FRACTIONAL ±                         | ENG APPR. |      | SIZE DWG. NO. REV                    |  |
|  |             | ANGULAR: MACH ± BEND ±               | MFG APPR. |      | A                                    |  |
|  |             | TWO PLACE DECIMAL ±                  | Q.A.      |      | SCALE: 1:4 WEIGHT: SHEET 10 OF 10    |  |
|  |             | THREE PLACE DECIMAL ±                | COMMENTS: |      |                                      |  |
|  |             | INTERPRET GEOMETRIC TOLERANCING PER: |           |      |                                      |  |
|  |             | MATERIAL                             |           |      |                                      |  |
|  | NEXT ASSY   | USED ON                              |           |      |                                      |  |
|  |             | FINISH                               |           |      |                                      |  |
|  | APPLICATION | DO NOT SCALE DRAWING                 |           |      |                                      |  |