

ITEM NO.	PART NUMBER	DESCRIPTION	QTY.	CUT
1	SON-W-24"-20W-BA-WF-TBL-WET-35K-FRAME	ALUMINUM 0.0635"	1	
2	SON-W-24"-20W-BA-WF-TBL-WET-35K-END CAP	ALUMINUM 0.0635"	2	
3	SON-W-24"-20W-BA-WF-TBL-WET-35K-LENS STRIP	ALUMINUM 0.0635"	2	
4	SON-W-24"-20W-BA-WF-TBL-WET-35K-LED SPACER	22 GAUGE	1	
5	SON-W-24"-20W-BA-WF-TBL-WET-35K-FIREPLATE	22 GAUGE	1	
6	SON-W-24"-20W-BA-WF-TBL-WET-35K-ACRYLIC	ACRYLIC	1	
7	SON-W-24"-20W-BA-WF-TBL-WET-35K-ALUMINUM BAR	1/4"X3/4" ALUMINUM FLAT BAR	1	
8	ESPEN VEL29070MVH-1	DRIVER	1	
9	AlfaLED_PN110B_RevC	LED	2	

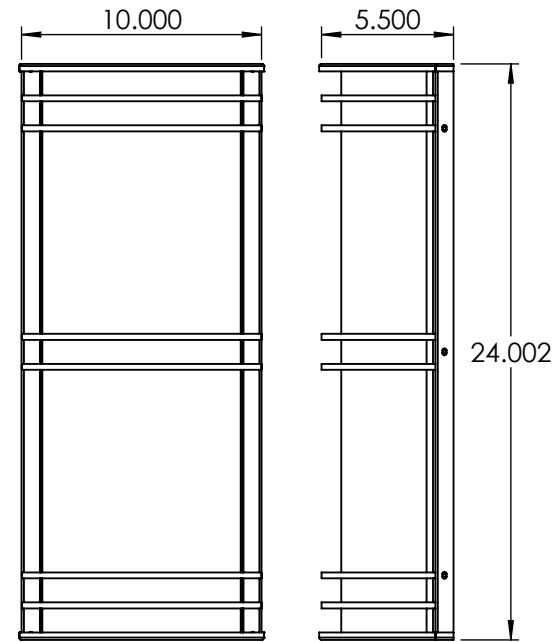
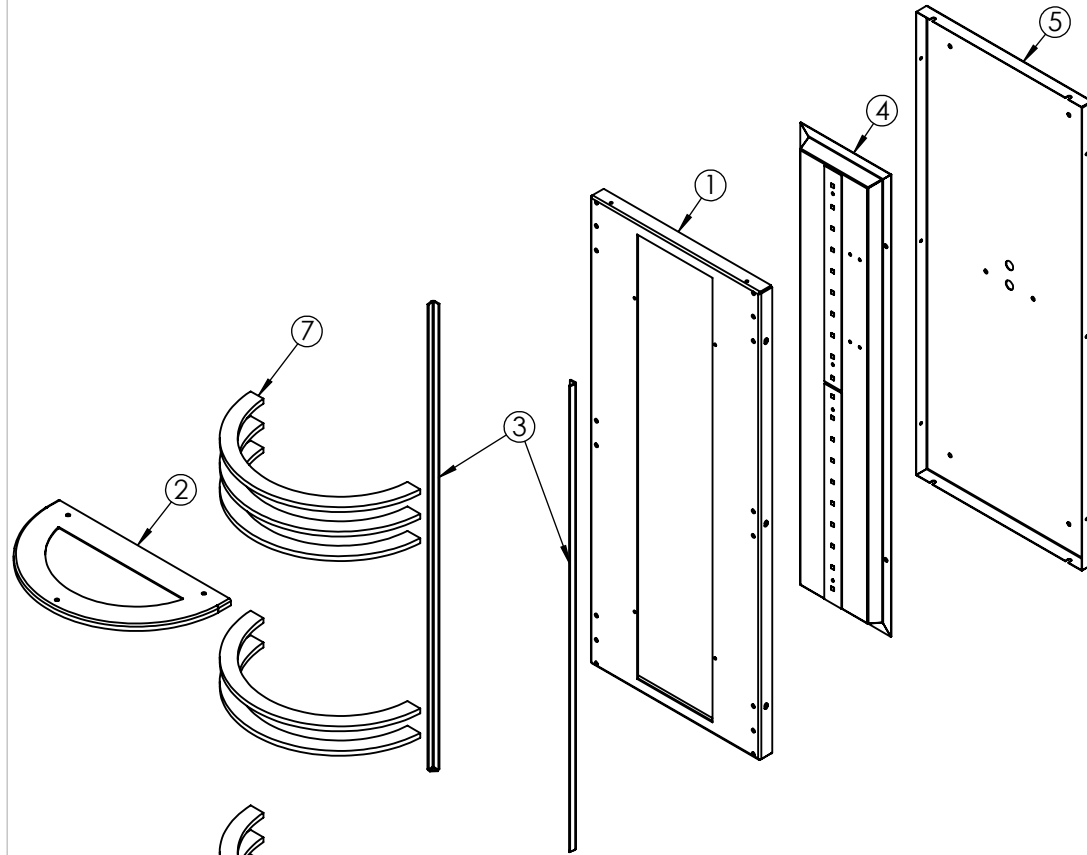

ALL BEND RADIUS .030"

UNLESS OTHERWISE SPECIFIED:

DIMENSIONS ARE IN INCHES
 TOLERANCES:
 FRACTIONAL ± .003
 ANGULAR: MACH ±.01 BEND ±
 TWO PLACE DECIMAL ±
 THREE PLACE DECIMAL ±.001

INTERPRET GEOMETRIC
 TOLERANCING PER:

MATERIAL

FINISH

	NAME	DATE
DRAWN		
CHECKED		
ENG APPR.		
MFG APPR.		
Q.A.		
COMMENTS:		

TITLE:

SON-W-24"-20W-BA-WF-TBL-WET-35K

SIZE	DWG. NO.	REV
A	TICKET 26434	

SCALE: 1:8	WEIGHT:	SHEET 1 OF 9
------------	---------	--------------

5

4

3

2

1

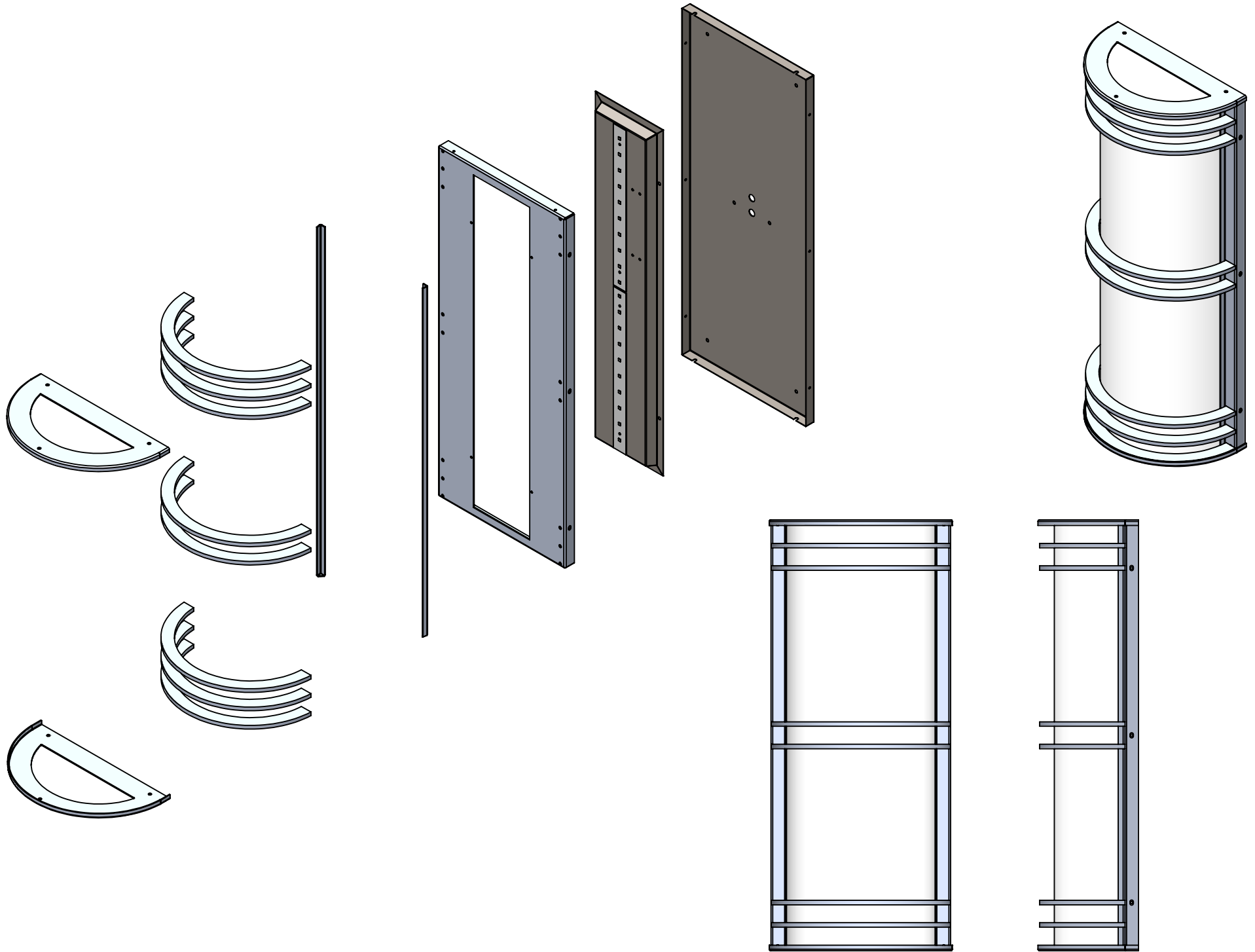

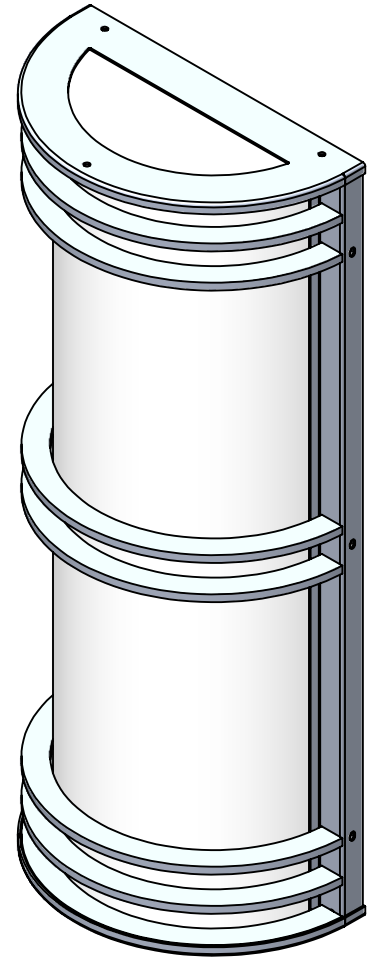
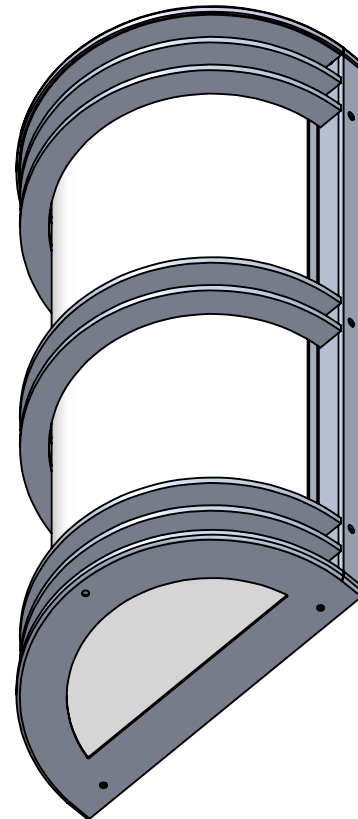
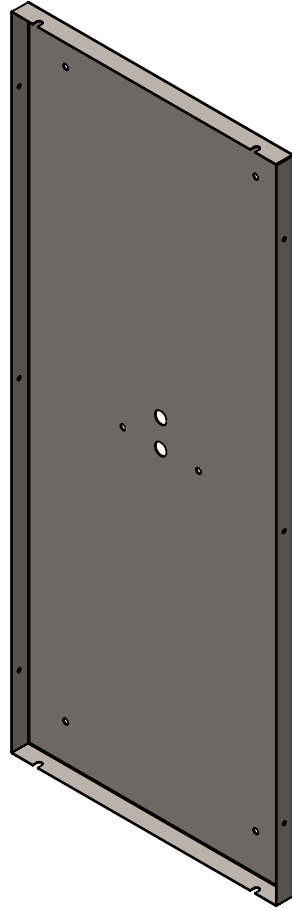
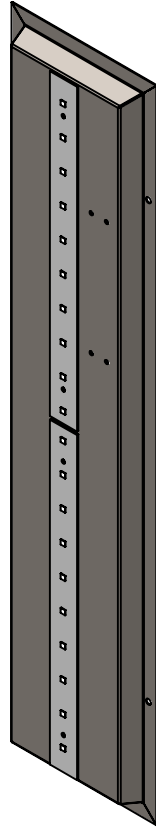
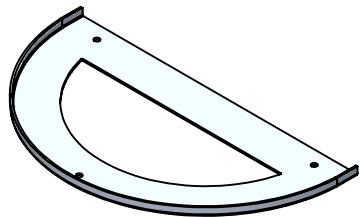
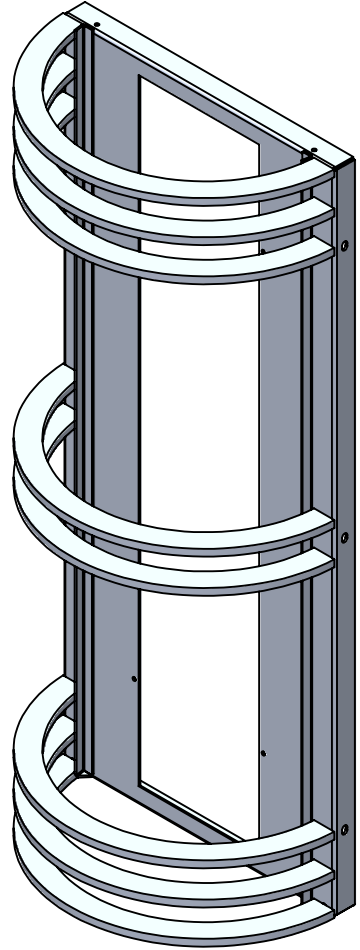
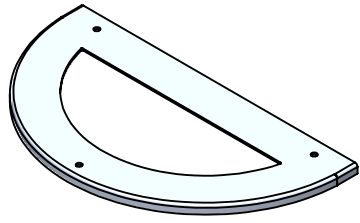

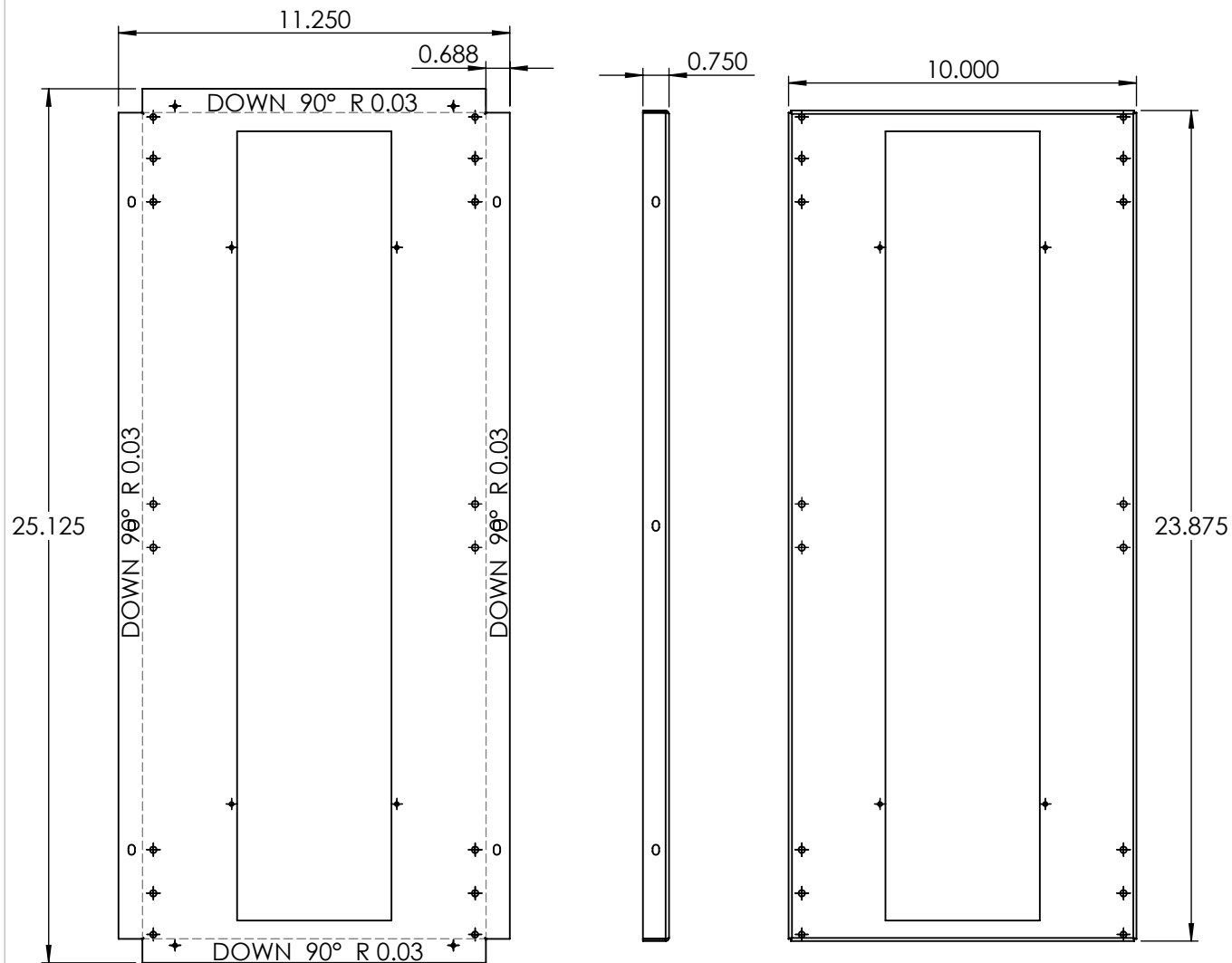

FRAME

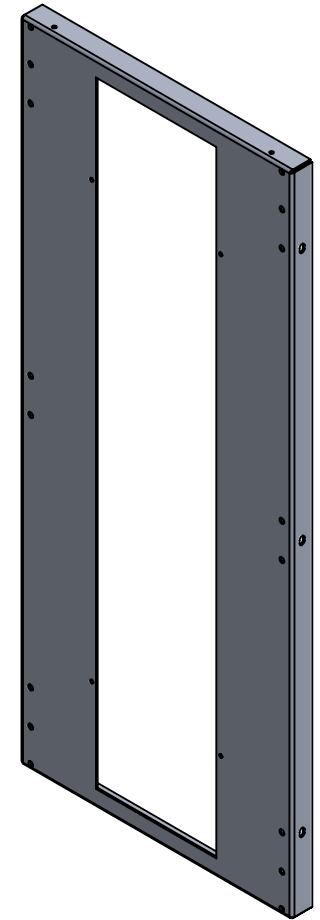

PROPRIETARY AND CONFIDENTIAL
 THE INFORMATION CONTAINED IN THIS DRAWING IS THE SOLE PROPERTY OF <INSERT COMPANY NAME HERE>. ANY REPRODUCTION IN PART OR AS A WHOLE WITHOUT THE WRITTEN PERMISSION OF <INSERT COMPANY NAME HERE> IS PROHIBITED.

		UNLESS OTHERWISE SPECIFIED:		NAME	DATE	ALUMINUM 0.0635"	
		DIMENSIONS ARE IN INCHES	DRAWN			TITLE:	
		TOLERANCES:	CHECKED			SON-W-24"-20W-BA-WF-TBL-WET-35K	
		FRACTIONAL ±	ENG APPR.			SIZE DWG. NO. REV	
		ANGULAR: MACH ± BEND ±	MFG APPR.			SCALE: 1:5 WEIGHT: SHEET 4 OF 9	
		TWO PLACE DECIMAL ±	Q.A.				
		THREE PLACE DECIMAL ±	COMMENTS:				
		INTERPRET GEOMETRIC TOLERANCING PER:					
		MATERIAL					
		FINISH					
NEXT ASSY	USED ON						
APPLICATION		DO NOT SCALE DRAWING					

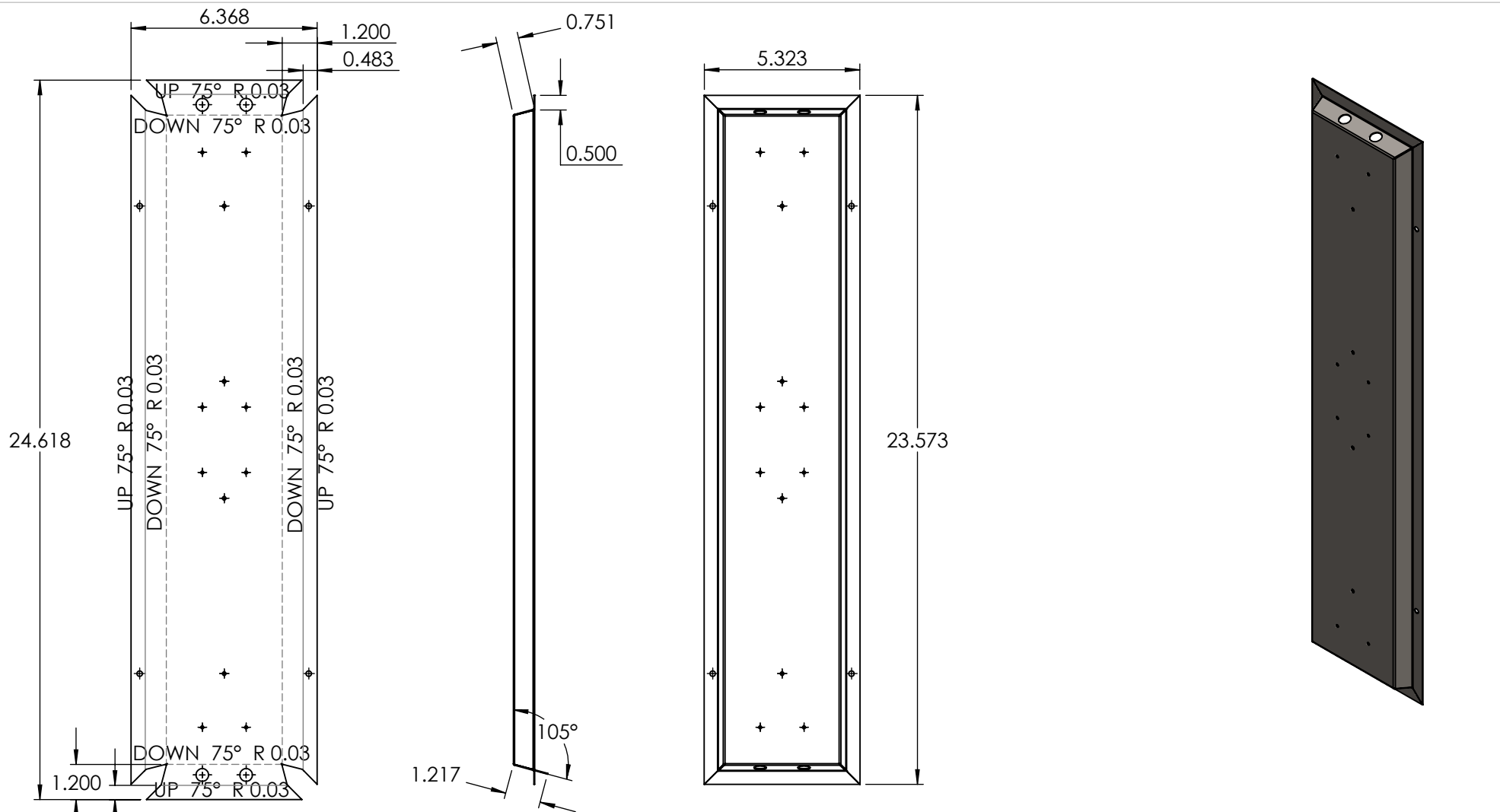

SPACER BACKPLATE

PROPRIETARY AND CONFIDENTIAL
 THE INFORMATION CONTAINED IN THIS DRAWING IS THE SOLE PROPERTY OF <INSERT COMPANY NAME HERE>. ANY REPRODUCTION IN PART OR AS A WHOLE WITHOUT THE WRITTEN PERMISSION OF <INSERT COMPANY NAME HERE> IS PROHIBITED.

		UNLESS OTHERWISE SPECIFIED:	NAME	DATE	22 GAUGE	
		DIMENSIONS ARE IN INCHES	DRAWN		TITLE: SON-W-24"-20W-BA-WF-TBL-WET-35K	
		TOLERANCES:	CHECKED			
		FRACTIONAL ±	ENG APPR.			
		ANGULAR: MACH ± BEND ±	MFG APPR.			
		TWO PLACE DECIMAL ±	Q.A.		SIZE DWG. NO. REV	
		THREE PLACE DECIMAL ±	COMMENTS:		SCALE: 1:5 WEIGHT: SHEET 5 OF 9	
NEXT ASSY	USED ON	MATERIAL				
APPLICATION		FINISH				
		DO NOT SCALE DRAWING				

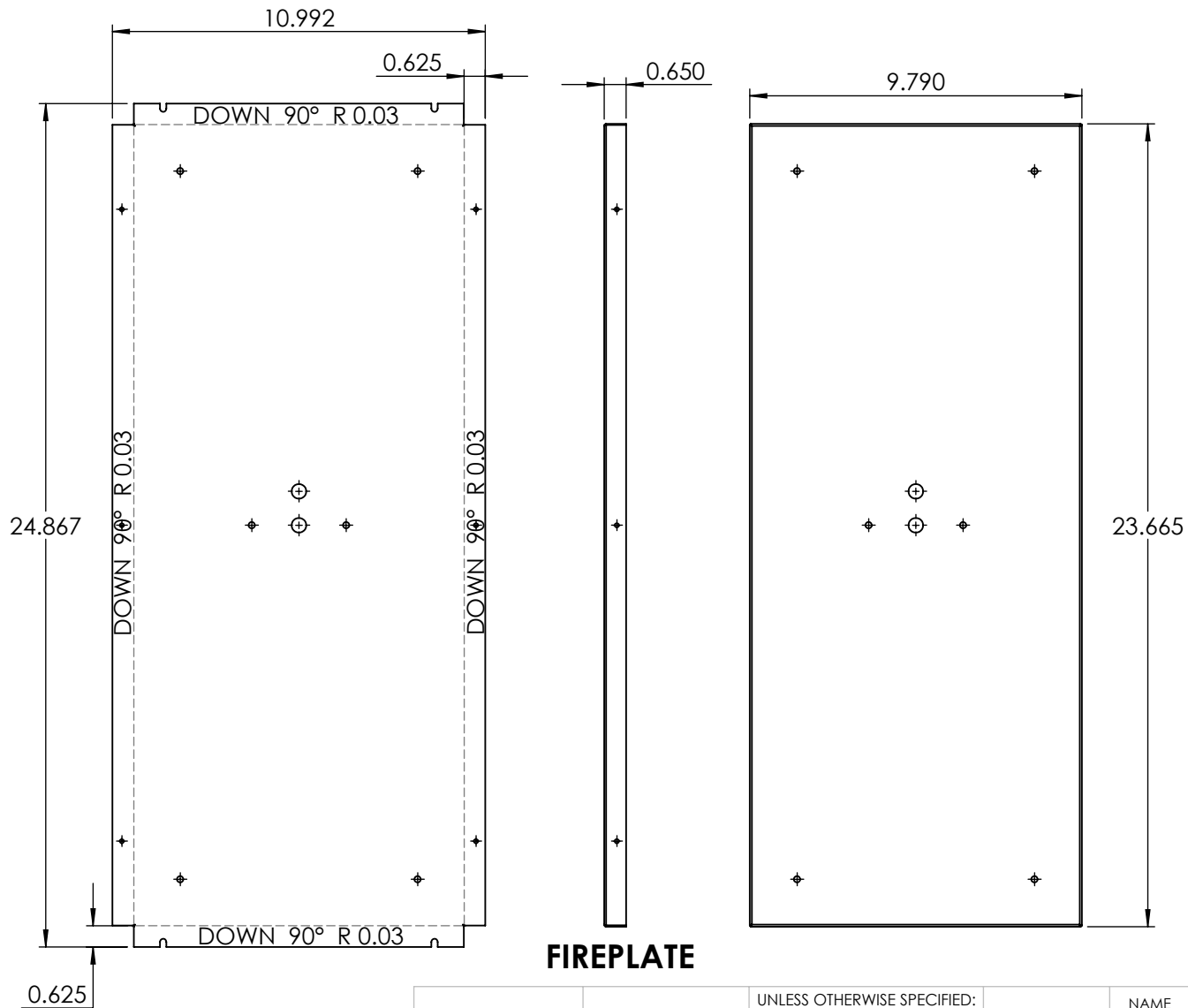

FIREPLATE

PROPRIETARY AND CONFIDENTIAL
 THE INFORMATION CONTAINED IN THIS DRAWING IS THE SOLE PROPERTY OF <INSERT COMPANY NAME HERE>. ANY REPRODUCTION IN PART OR AS A WHOLE WITHOUT THE WRITTEN PERMISSION OF <INSERT COMPANY NAME HERE> IS PROHIBITED.

		UNLESS OTHERWISE SPECIFIED:		NAME	DATE
		DIMENSIONS ARE IN INCHES	DRAWN		
		TOLERANCES:	CHECKED		
		FRACTIONAL ±	ENG APPR.		
		ANGULAR: MACH ± BEND ±	MFG APPR.		
		TWO PLACE DECIMAL ±	Q.A.		
		THREE PLACE DECIMAL ±	COMMENTS:		
		INTERPRET GEOMETRIC TOLERANCING PER:			
		MATERIAL			
NEXT ASSY	USED ON	FINISH			
APPLICATION		DO NOT SCALE DRAWING			

22 GAUGE		
TITLE:		
SON-W-24"-20W-BA-WF-TBL-WET-35K		
SIZE	DWG. NO.	REV
A		
SCALE: 1:5	WEIGHT:	SHEET 6 OF 9

21/32"

9 25/32"

4 X ϕ 3/16" MOUNT HOLES

ϕ 7/16"
WIREWAY HOLE

ϕ 7/16"
CENTER MOUNTING HOLE

23 21/32"

20 7/8"

1"

7"

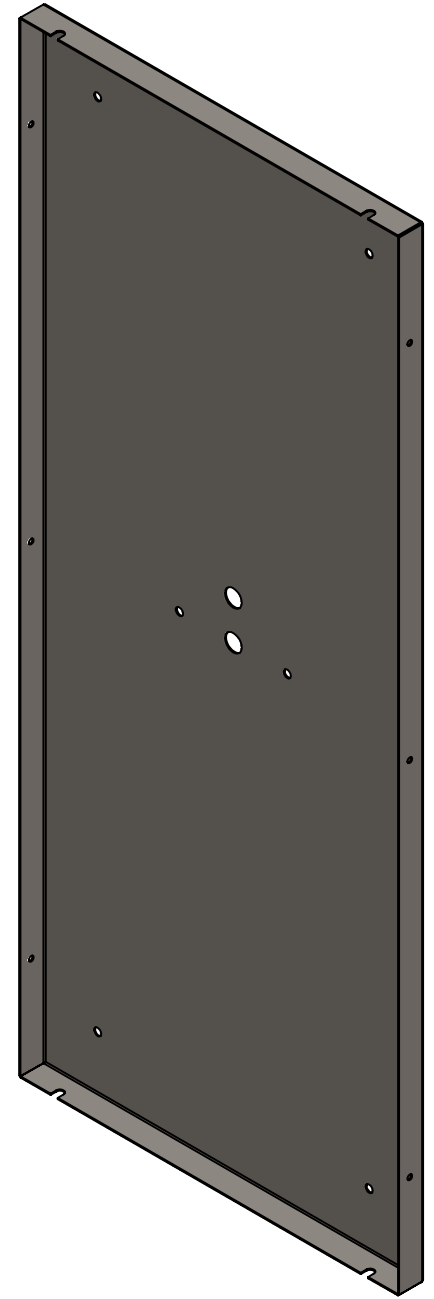

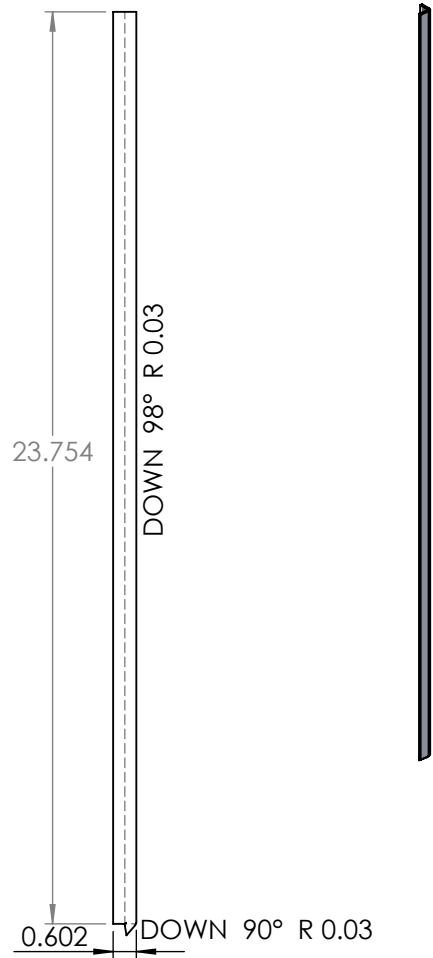

LENS STRIP

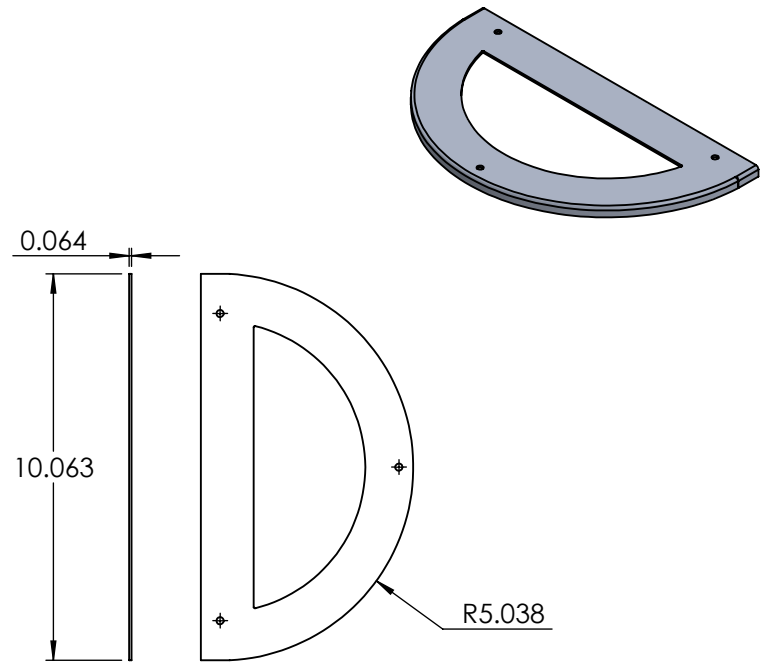

CAP

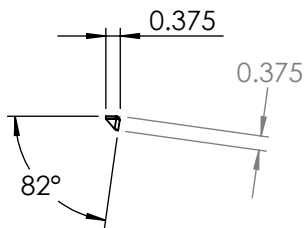

PROPRIETARY AND CONFIDENTIAL
 THE INFORMATION CONTAINED IN THIS DRAWING IS THE SOLE PROPERTY OF <INSERT COMPANY NAME HERE>. ANY REPRODUCTION IN PART OR AS A WHOLE WITHOUT THE WRITTEN PERMISSION OF <INSERT COMPANY NAME HERE> IS PROHIBITED.

		UNLESS OTHERWISE SPECIFIED:		NAME	DATE	ALUMINUM 0.0635"		
		DIMENSIONS ARE IN INCHES				TITLE:		
		TOLERANCES:				SON-W-24"-20W-BA-WF-TBL-WET-35K		
		FRACTIONAL ±		DRAWN				
		ANGULAR: MACH ± BEND ±		CHECKED				
		TWO PLACE DECIMAL ±		ENG APPR.				
		THREE PLACE DECIMAL ±		MFG APPR.				
		INTERPRET GEOMETRIC TOLERANCING PER:		Q.A.				
		MATERIAL		COMMENTS:				
		FINISH				SIZE	DWG. NO.	REV
NEXT ASSY	USED ON					A		
APPLICATION		DO NOT SCALE DRAWING				SCALE: 1:5	WEIGHT:	SHEET 8 OF 9

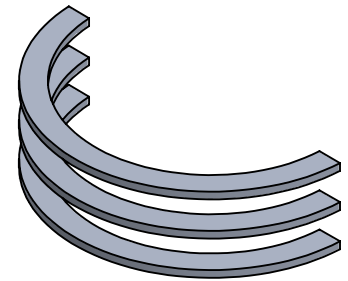
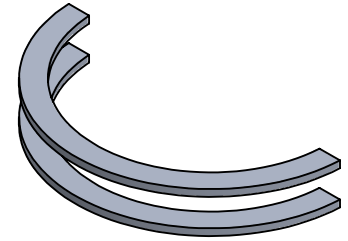
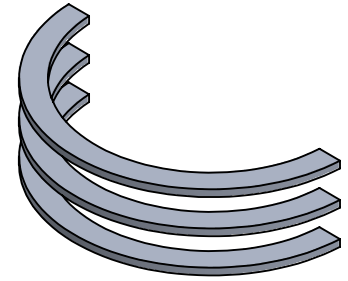
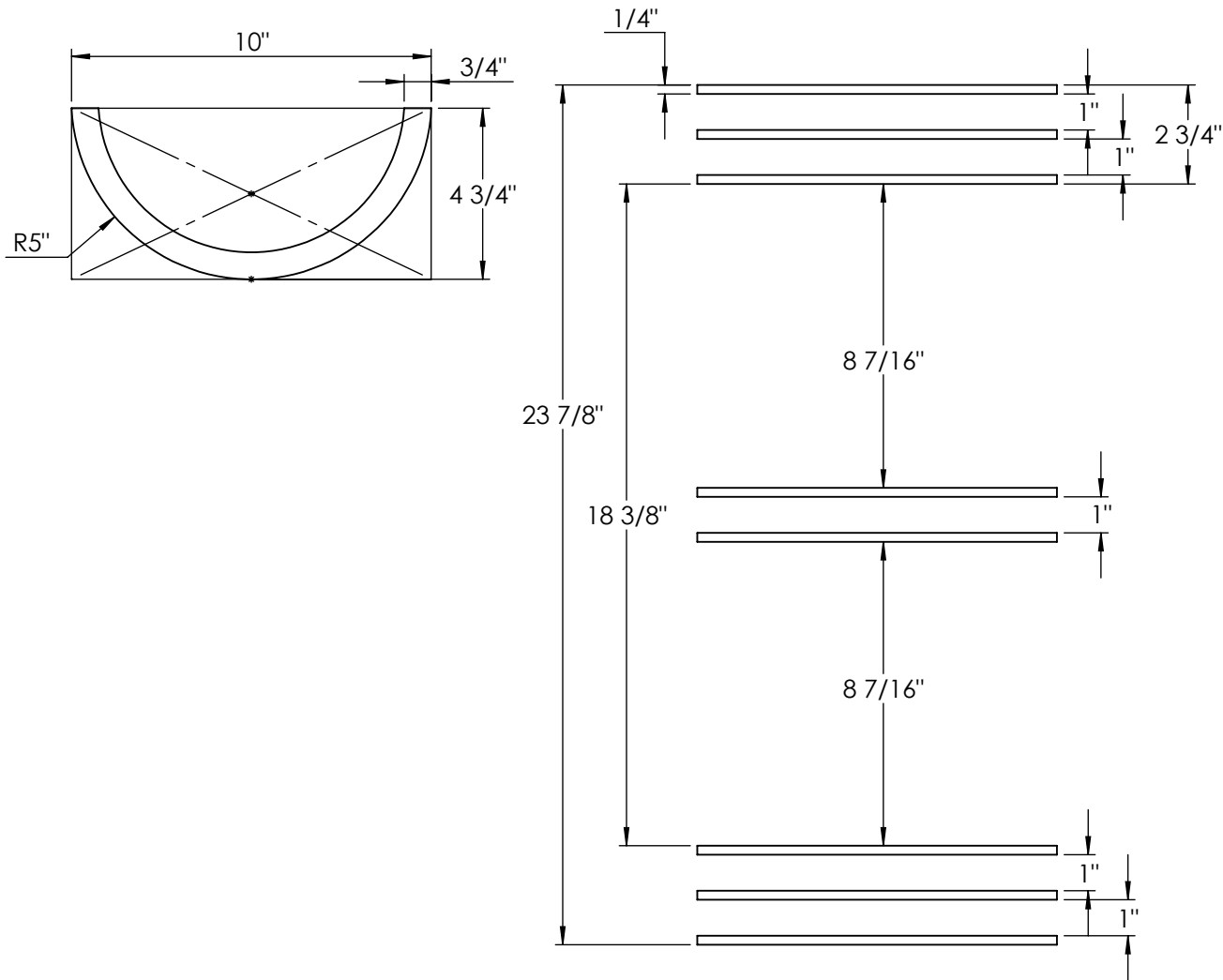

PROPRIETARY AND CONFIDENTIAL
 THE INFORMATION CONTAINED IN THIS DRAWING IS THE SOLE PROPERTY OF <INSERT COMPANY NAME HERE>. ANY REPRODUCTION IN PART OR AS A WHOLE WITHOUT THE WRITTEN PERMISSION OF <INSERT COMPANY NAME HERE> IS PROHIBITED.

		UNLESS OTHERWISE SPECIFIED:		NAME	DATE
		DIMENSIONS ARE IN INCHES	DRAWN		
		TOLERANCES:	CHECKED		
		FRACTIONAL ±	ENG APPR.		
		ANGULAR: MACH ± BEND ±	MFG APPR.		
		TWO PLACE DECIMAL ±	Q.A.		
		THREE PLACE DECIMAL ±	COMMENTS:		
		INTERPRET GEOMETRIC TOLERANCING PER:			
		MATERIAL			
NEXT ASSY	USED ON	FINISH			
APPLICATION		DO NOT SCALE DRAWING			

1/4"X3/4" ALUMINUM FLAT BAR		
TITLE:		
SON-W-24"-20W-BA-WF-TBL-WET-35K		
SIZE	DWG. NO.	REV
A		
SCALE: 1:5	WEIGHT:	SHEET 9 OF 9