

ITEM NO.	PART NUMBER	DESCRIPTION	QTY.	CUT
1	EVOL21-W-27-224LED-CV-HO-27K-0.250" THICK PLATE	1/4" INCH ALUMINUM PLATE	1	
2	EVOL21-W-27-224LED-CV-HO-27K-FRAME SPACER	ALUMINUM 0.0635"	1	
3	EVOL21-W-27-224LED-CV-HO-27K-BACKPLATE	ALUMINUM 0.0635"	1	
4	EVOL21-W-27-224LED-CV-HO-27K-FIREPLATE	ALUMINUM 0.0635"	1	
5	EVOL21-W-27-224LED-CV-HO-27K-LED SPACER	ALUMINUM 0.0635"	1	
6	EVOL21-W-27-224LED-CV-HO-27K-FRAME TAB	25 GAUGE	4	
7	EVOL21-W-27-224LED-CV-HO-27K-VERTICAL BAR	1/2" SQUARE ALUMINUM BAR	1	
8	EVOL21-W-27-224LED-CV-HO-27K-HORIZONTAL BAR	3/8" SQUARE ALUMINUM BAR	1	
9	EVOLX-W-27-ROUND FORMED LENS	ACRYLIC	1	
10	AltalLED PN110B RevC	LED	4	
11	KTLD-25-UV-700-VDIM-LA1	DRIVER	2	

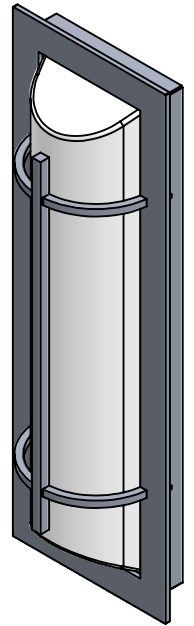
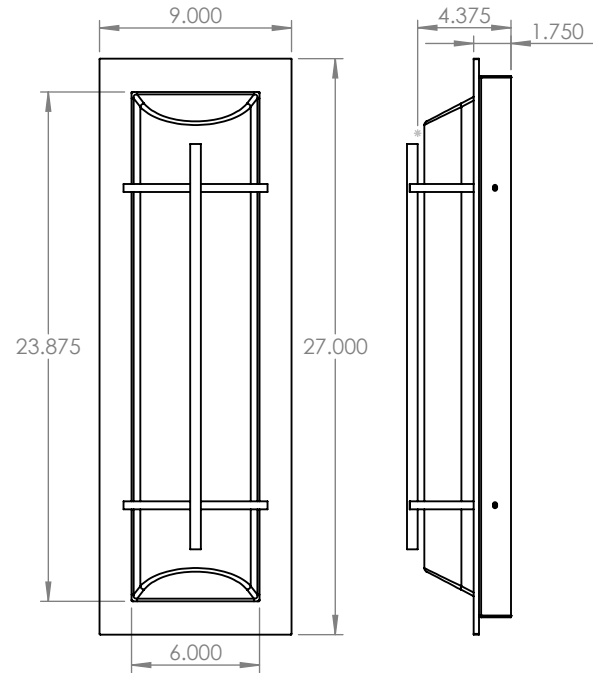
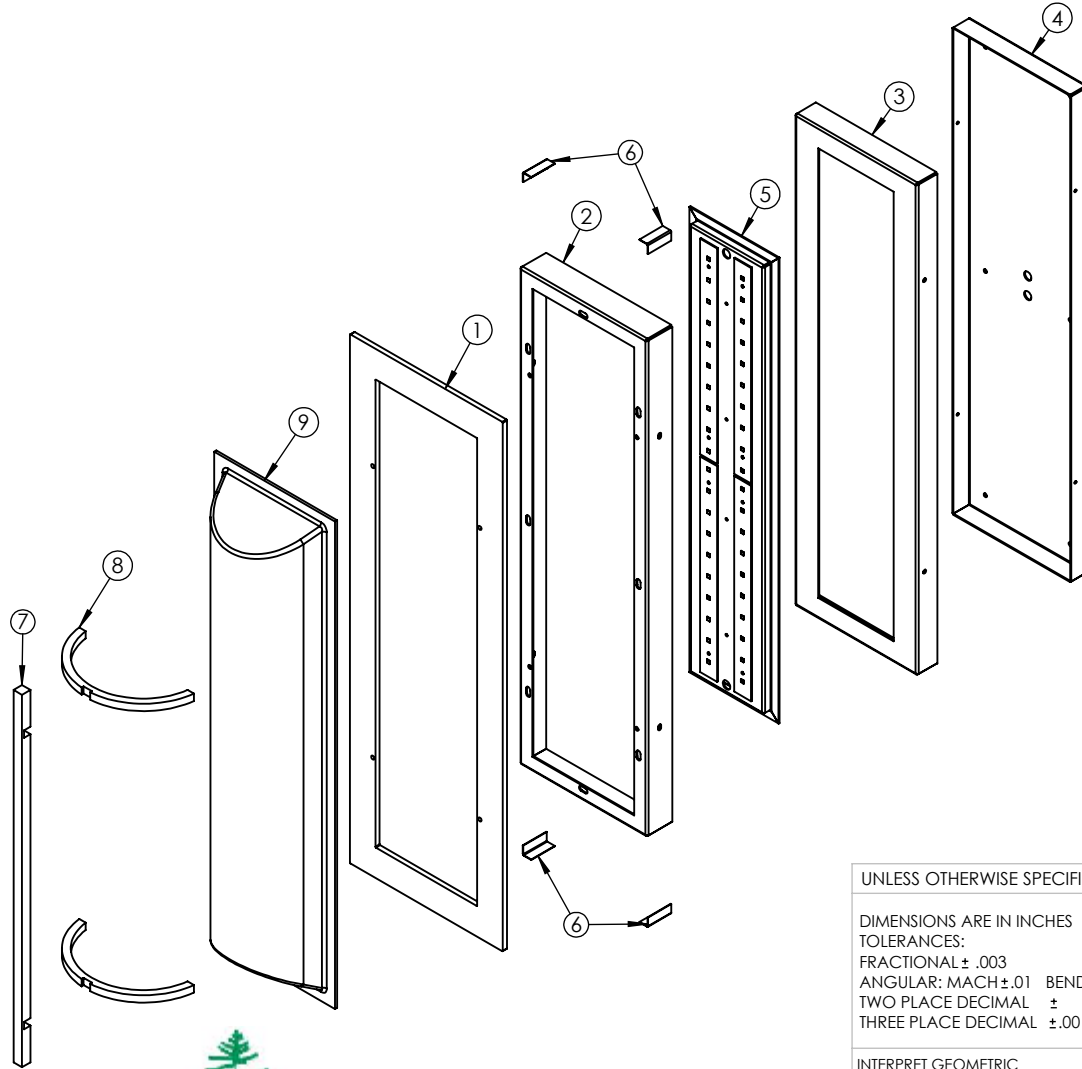

ALL BEND RADIUS .030"

APPLICATION

DO NOT SCALE DRAWING

UNLESS OTHERWISE SPECIFIED:

DIMENSIONS ARE IN INCHES
 TOLERANCES:
 FRACTIONAL ± .003
 ANGULAR: MACH ± .01 BEND ±
 TWO PLACE DECIMAL ±
 THREE PLACE DECIMAL ±.001

INTERPRET GEOMETRIC
 TOLERANCING PER:

MATERIAL

FINISH

NAME	DATE

DRAWN
 CHECKED
 ENG APPR.
 MFG APPR.

Q.A.
 COMMENTS:

TITLE:

EVOL21-W-27-224LED-CV-HO-27K

SIZE	DWG. NO.	REV
A	TICKET 26824	

SCALE: 1:8 WEIGHT: SHEET 1 OF 9

5

4

3

2

1

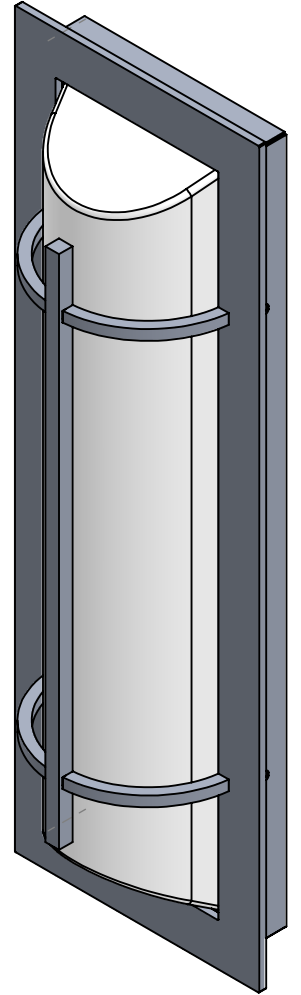
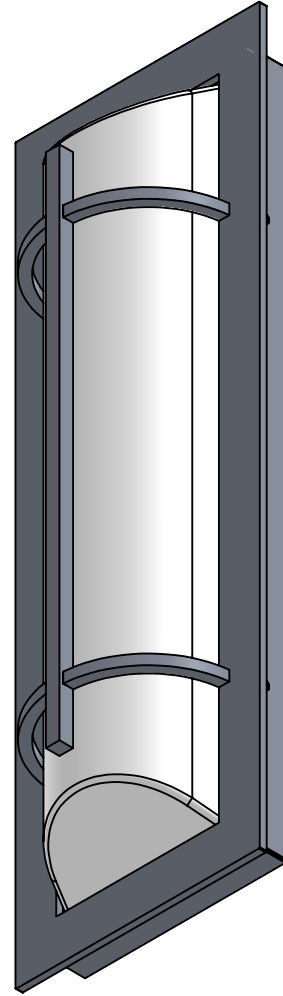
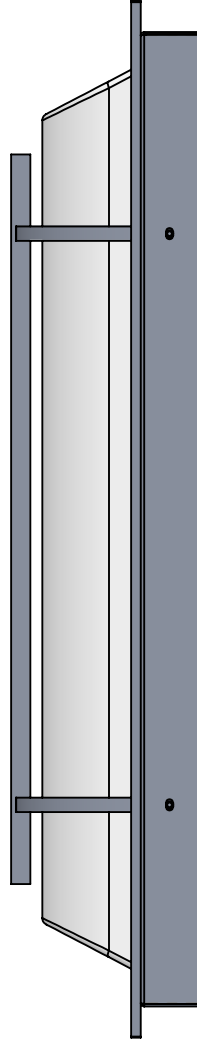
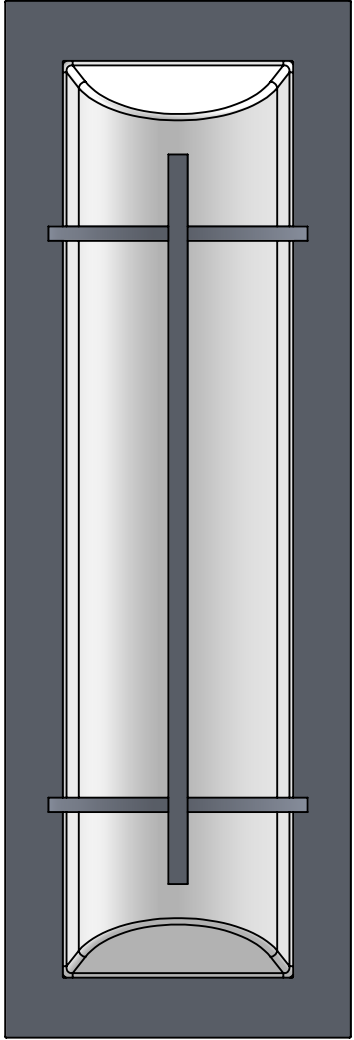
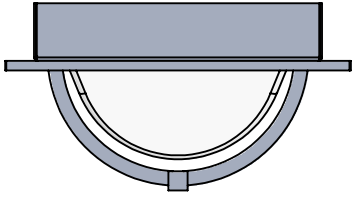

**BAR ACCENT TAPPED AND BOLTED TO FRAME WITH ACCENT
PLATE INBETWEEN**

**FRAME AND PLATE WELDED FOR
ADDED STRENGTH**

**TABS SPOT WELDED TO FRAME
ON ALL 4 CORNERS**

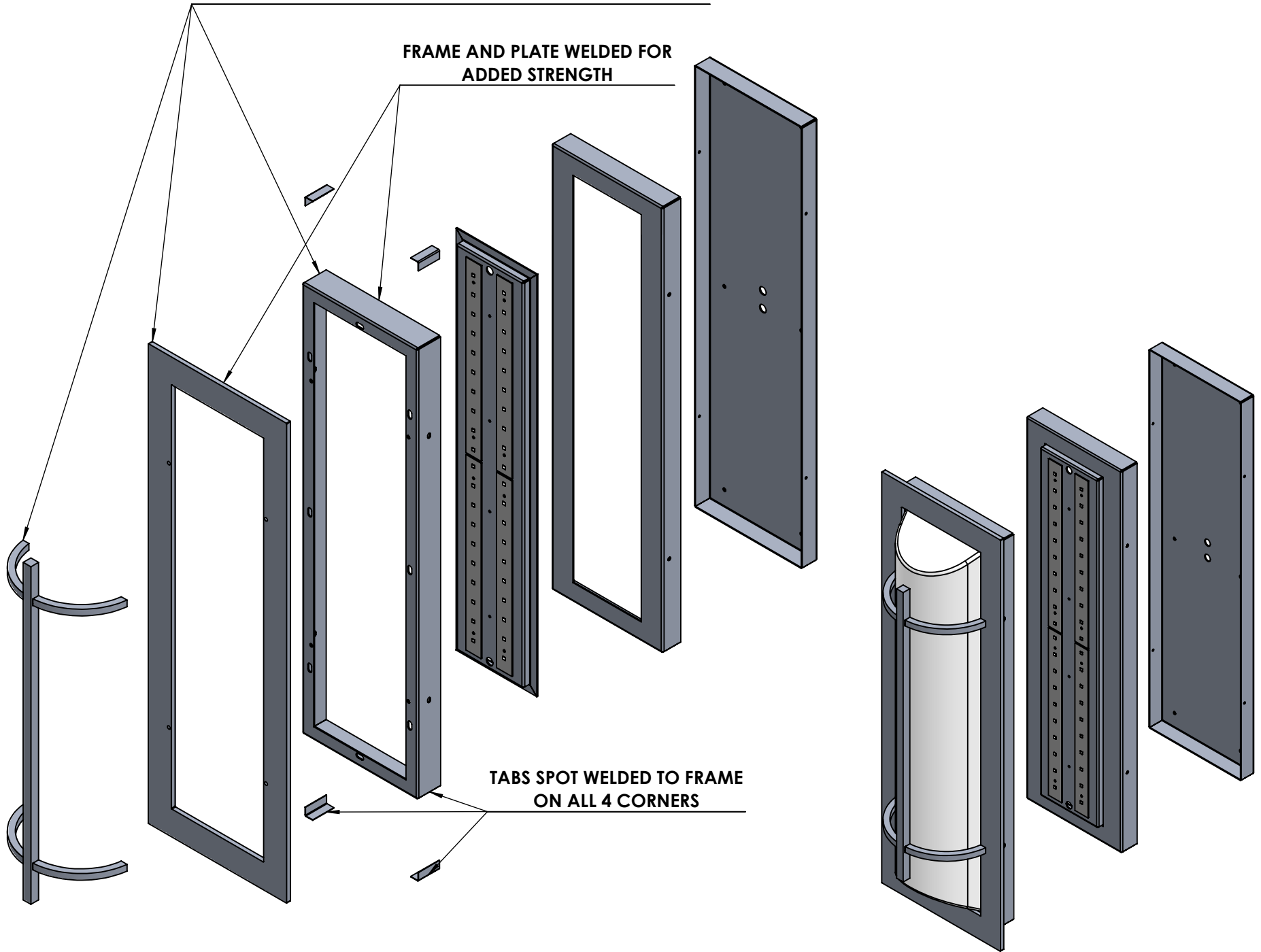

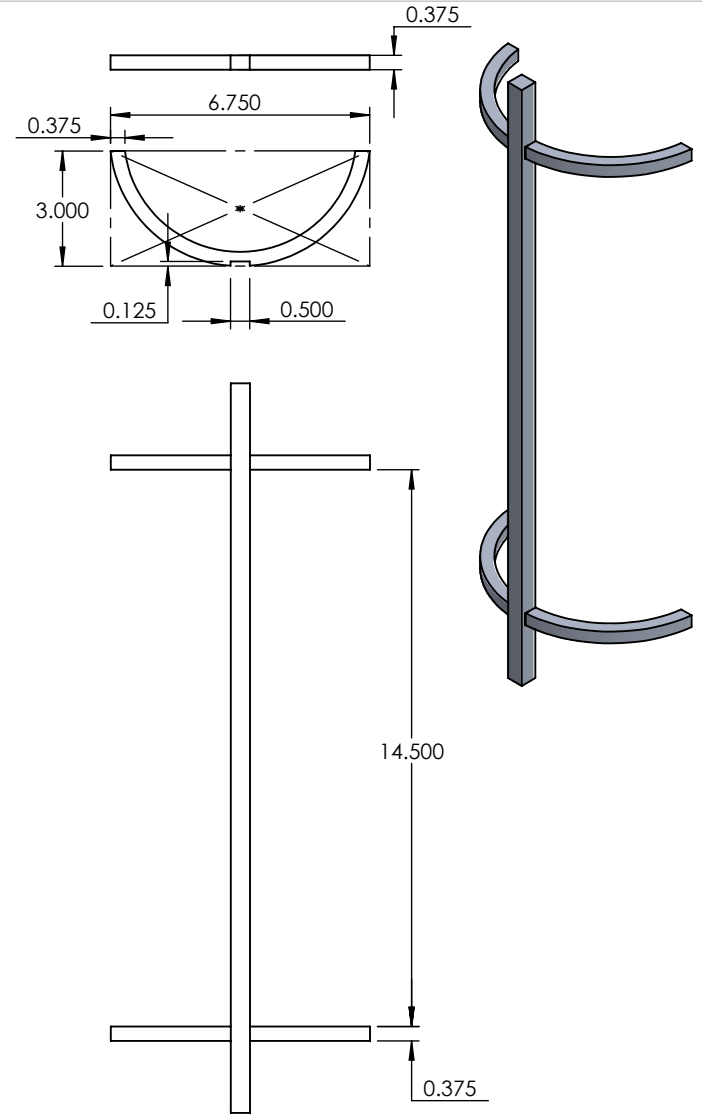
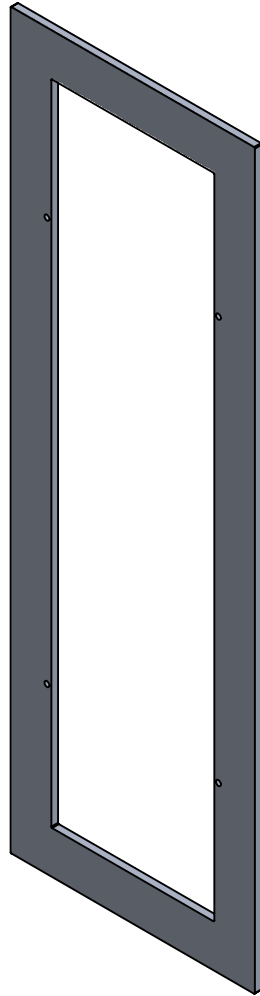
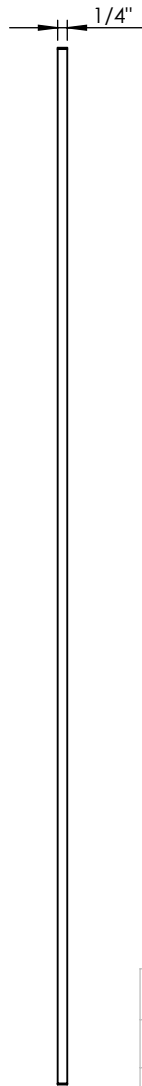
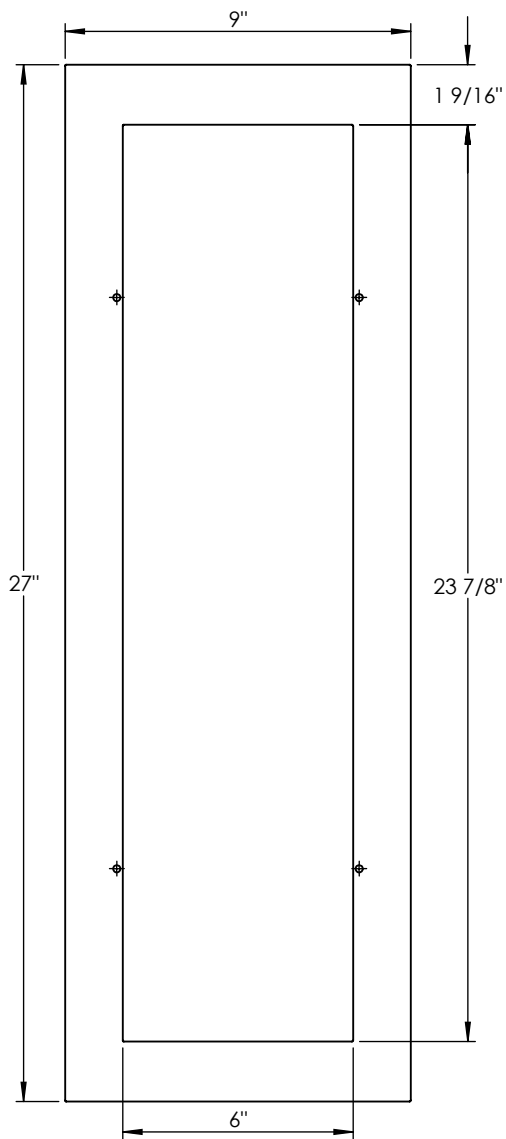

UNLESS OTHERWISE SPECIFIED:		NAME	DATE
DIMENSIONS ARE IN INCHES		DRAWN	
TOLERANCES:		CHECKED	
FRACTIONAL ±		ENG APPR.	
ANGULAR: MACH ± BEND ±		MFG APPR.	
TWO PLACE DECIMAL ±		Q.A.	
THREE PLACE DECIMAL ±		COMMENTS:	
INTERPRET GEOMETRIC TOLERANCING PER:			
MATERIAL			
FINISH			
NEXT ASSY	USED ON		
APPLICATION			
DO NOT SCALE DRAWING			

1/4" INCH ALUMINUM PLATE		
TITLE:		
EVOL21-W-27-224LED-CV-HO-27K		
SIZE	DWG. NO.	REV
A		
SCALE: 1:5	WEIGHT:	SHEET 4 OF 9

PROPRIETARY AND CONFIDENTIAL
 THE INFORMATION CONTAINED IN THIS DRAWING IS THE SOLE PROPERTY OF <INSERT COMPANY NAME HERE>. ANY REPRODUCTION IN PART OR AS A WHOLE WITHOUT THE WRITTEN PERMISSION OF <INSERT COMPANY NAME HERE> IS PROHIBITED.

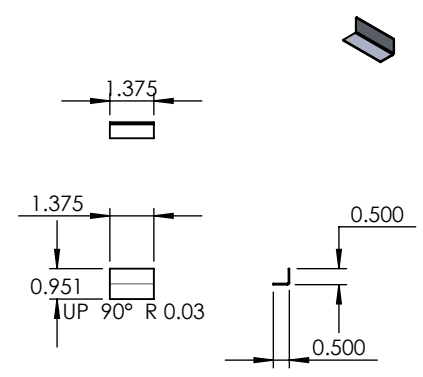
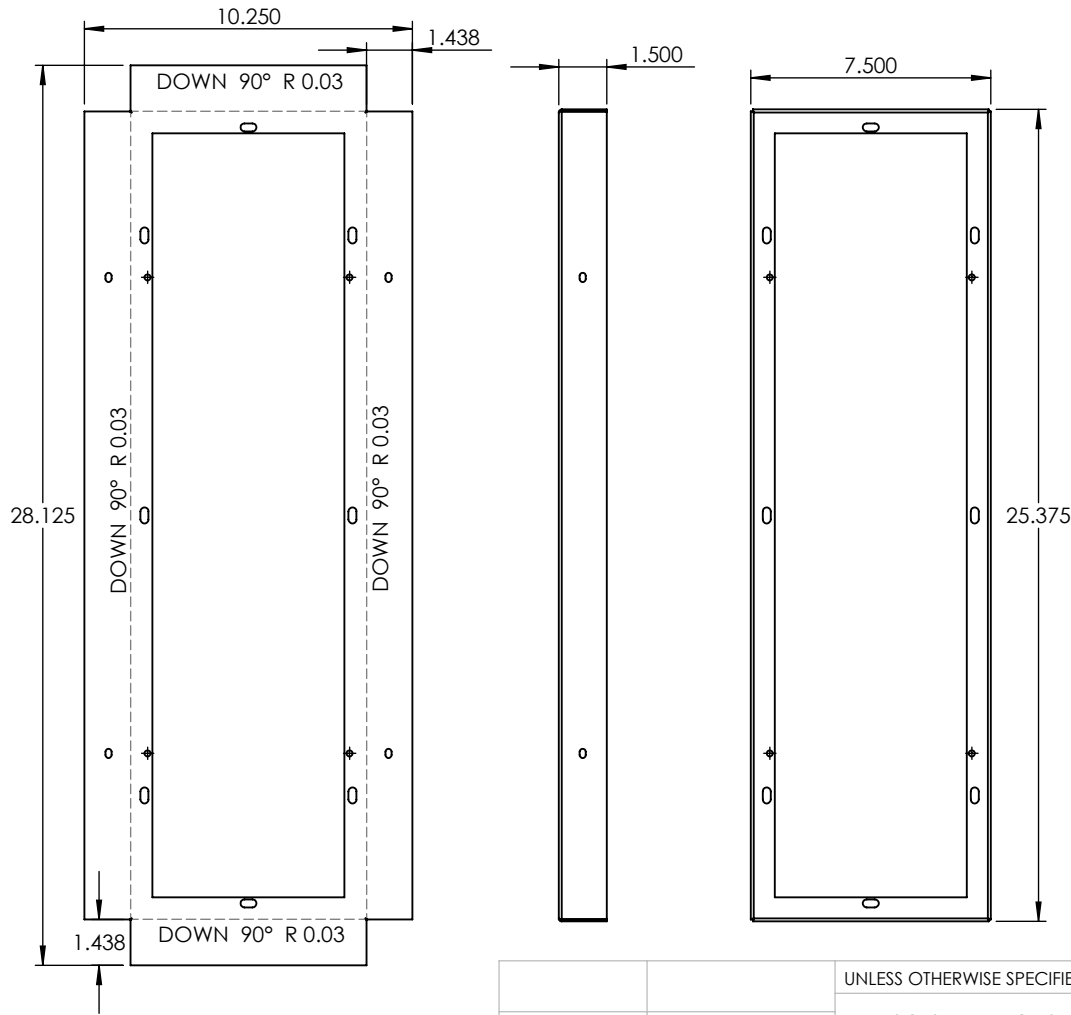

PROPRIETARY AND CONFIDENTIAL
 THE INFORMATION CONTAINED IN THIS DRAWING IS THE SOLE PROPERTY OF <INSERT COMPANY NAME HERE>. ANY REPRODUCTION IN PART OR AS A WHOLE WITHOUT THE WRITTEN PERMISSION OF <INSERT COMPANY NAME HERE> IS PROHIBITED.

		UNLESS OTHERWISE SPECIFIED:		NAME	DATE
		DIMENSIONS ARE IN INCHES	DRAWN		
		TOLERANCES:	CHECKED		
		FRACTIONAL ±	ENG APPR.		
		ANGULAR: MACH ± BEND ±	MFG APPR.		
		TWO PLACE DECIMAL ±	Q.A.		
		THREE PLACE DECIMAL ±	COMMENTS:		
		INTERPRET GEOMETRIC TOLERANCING PER:			
		MATERIAL			
		FINISH			
NEXT ASSY	USED ON				
APPLICATION		DO NOT SCALE DRAWING			

ALUMINUM 0.0635"		
TITLE:		
EVOL21-W-27-224LED-CV-HO-27K		
SIZE	DWG. NO.	REV
A		
SCALE: 1:5	WEIGHT:	SHEET 5 OF 9

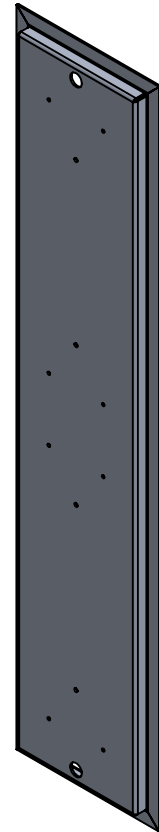
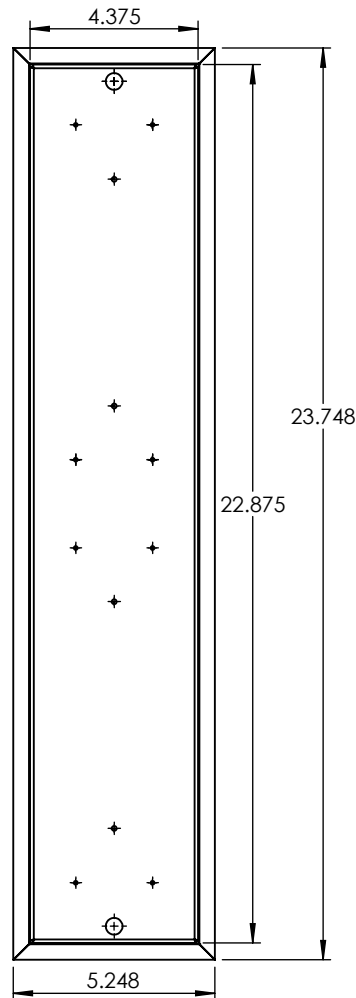
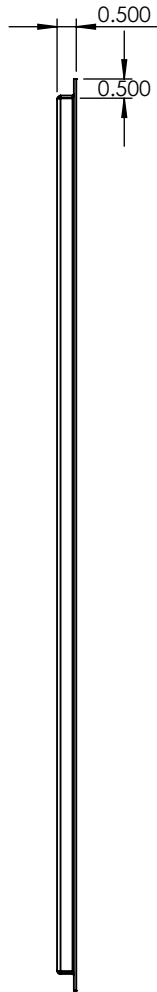
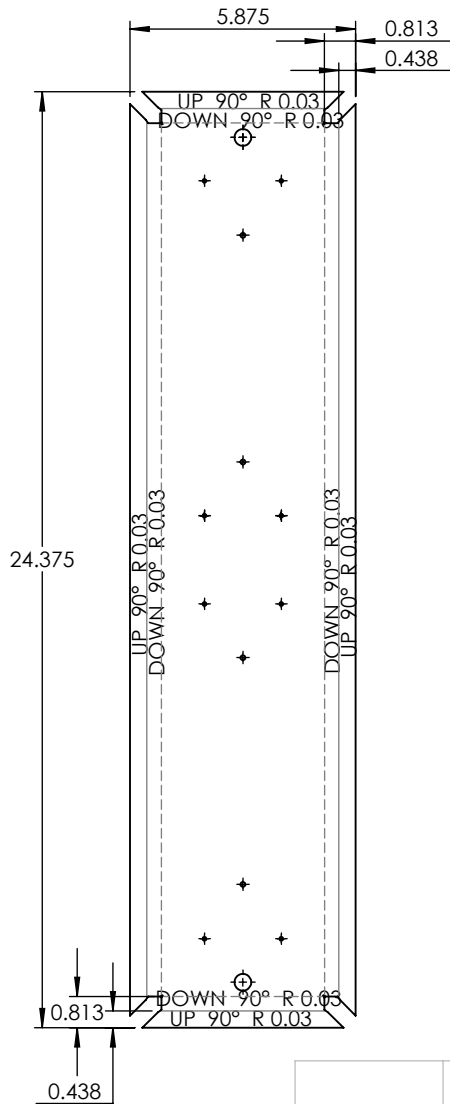

PROPRIETARY AND CONFIDENTIAL
 THE INFORMATION CONTAINED IN THIS DRAWING IS THE SOLE PROPERTY OF <INSERT COMPANY NAME HERE>. ANY REPRODUCTION IN PART OR AS A WHOLE WITHOUT THE WRITTEN PERMISSION OF <INSERT COMPANY NAME HERE> IS PROHIBITED.

		UNLESS OTHERWISE SPECIFIED:		NAME	DATE
		DIMENSIONS ARE IN INCHES	DRAWN		
		TOLERANCES:	CHECKED		
		FRACTIONAL ±	ENG APPR.		
		ANGULAR: MACH ± BEND ±	MFG APPR.		
		TWO PLACE DECIMAL ±	Q.A.		
		THREE PLACE DECIMAL ±	COMMENTS:		
		INTERPRET GEOMETRIC TOLERANCING PER:			
		MATERIAL			
		FINISH			
NEXT ASSY	USED ON				
APPLICATION		DO NOT SCALE DRAWING			

ALUMINUM 0.0635"		
TITLE:		
EVOL21-W-27-224LED-CV-HO-27K		
SIZE	DWG. NO.	REV
A		
SCALE: 1:5	WEIGHT:	SHEET 6 OF 9

5

4

3

2

1

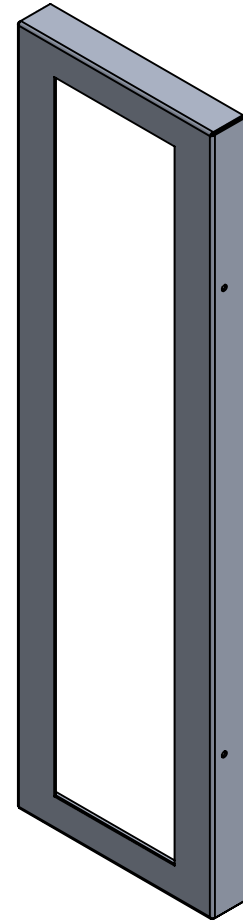
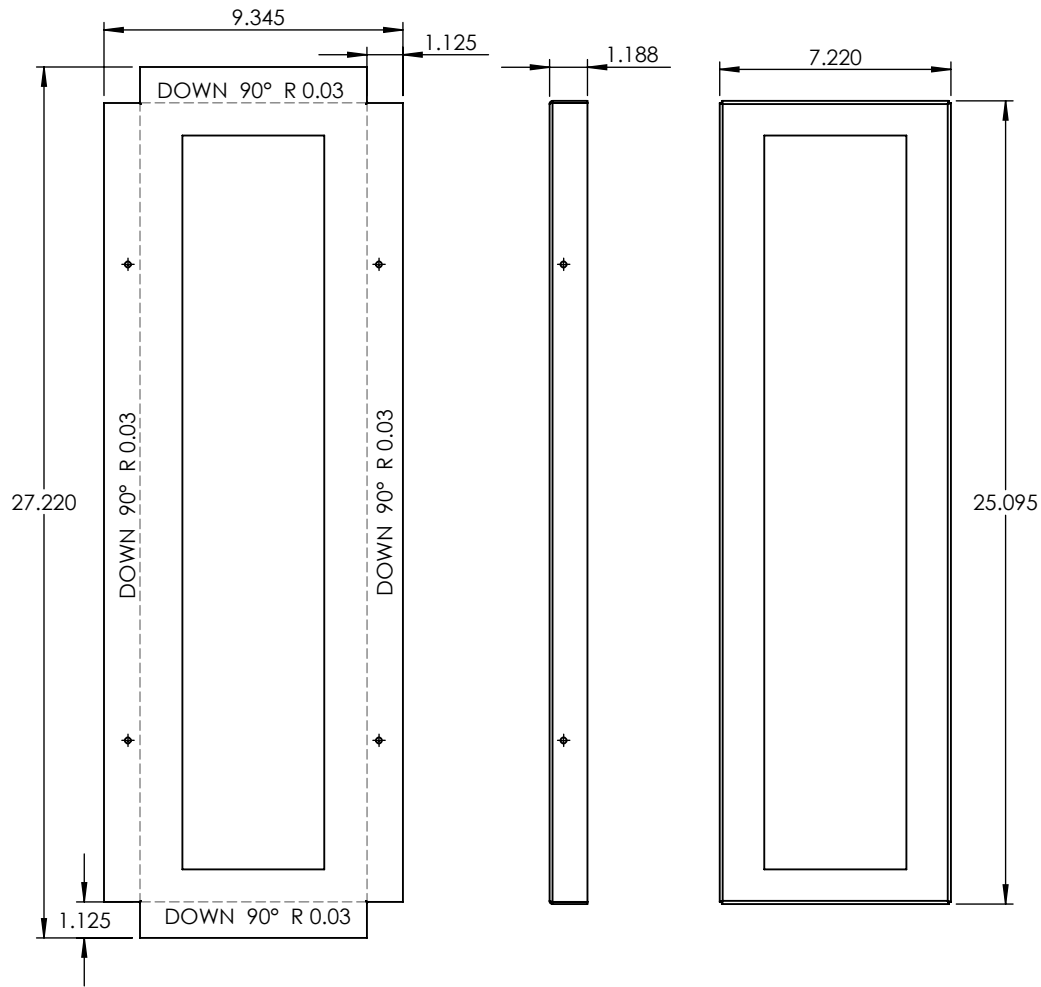

PROPRIETARY AND CONFIDENTIAL
 THE INFORMATION CONTAINED IN THIS DRAWING IS THE SOLE PROPERTY OF <INSERT COMPANY NAME HERE>. ANY REPRODUCTION IN PART OR AS A WHOLE WITHOUT THE WRITTEN PERMISSION OF <INSERT COMPANY NAME HERE> IS PROHIBITED.

		UNLESS OTHERWISE SPECIFIED:		NAME	DATE
		DIMENSIONS ARE IN INCHES	DRAWN		
		TOLERANCES:	CHECKED		
		FRACTIONAL ±	ENG APPR.		
		ANGULAR: MACH ± BEND ±	MFG APPR.		
		TWO PLACE DECIMAL ±	Q.A.		
		THREE PLACE DECIMAL ±	COMMENTS:		
		INTERPRET GEOMETRIC TOLERANCING PER:			
		MATERIAL			
		FINISH			
NEXT ASSY	USED ON				
APPLICATION		DO NOT SCALE DRAWING			

ALUMINUM 0.0635"		
TITLE:		
EVOL21-W-27-224LED-CV-HO-27K		
SIZE	DWG. NO.	REV
A		
SCALE: 1:5	WEIGHT:	SHEET 7 OF 9

5

4

3

2

1

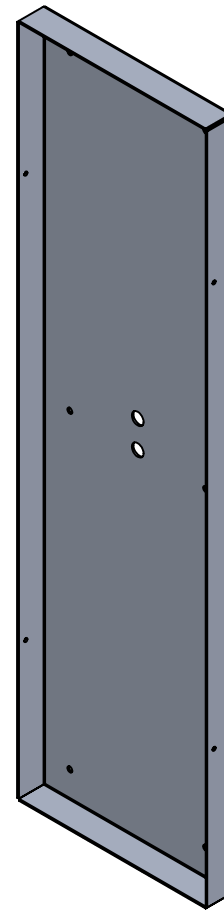
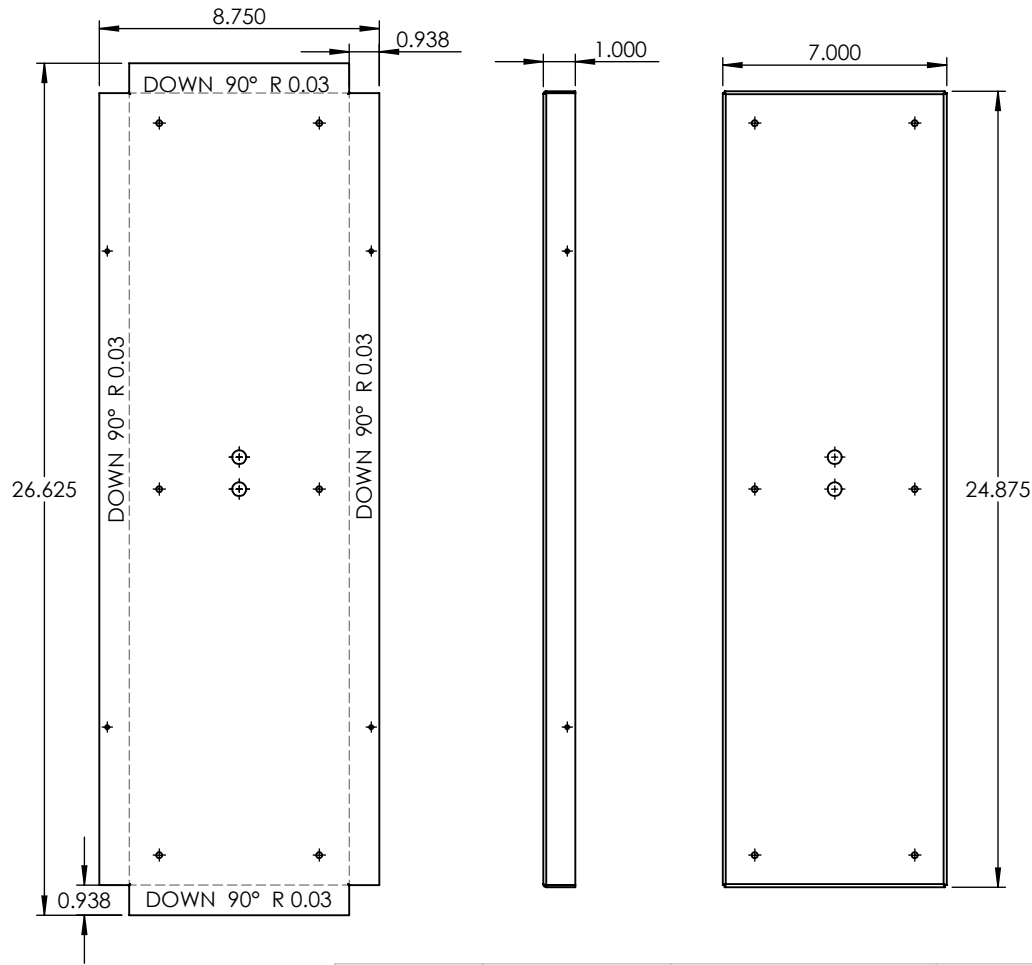

PROPRIETARY AND CONFIDENTIAL
 THE INFORMATION CONTAINED IN THIS DRAWING IS THE SOLE PROPERTY OF <INSERT COMPANY NAME HERE>. ANY REPRODUCTION IN PART OR AS A WHOLE WITHOUT THE WRITTEN PERMISSION OF <INSERT COMPANY NAME HERE> IS PROHIBITED.

		UNLESS OTHERWISE SPECIFIED:	NAME	DATE	ALUMINUM 0.0635"	
		DIMENSIONS ARE IN INCHES	DRAWN		TITLE:	
		TOLERANCES:	CHECKED		EVOL21-W-27-224LED-CV-HO-27K	
		FRACTIONAL ±	ENG APPR.		SIZE DWG. NO. REV	
		ANGULAR: MACH ± BEND ±	MFG APPR.		A	
		TWO PLACE DECIMAL ±	Q.A.		SCALE: 1:5 WEIGHT: SHEET 8 OF 9	
		THREE PLACE DECIMAL ±	COMMENTS:			
		INTERPRET GEOMETRIC TOLERANCING PER:				
		MATERIAL				
NEXT ASSY	USED ON	FINISH				
APPLICATION		DO NOT SCALE DRAWING				

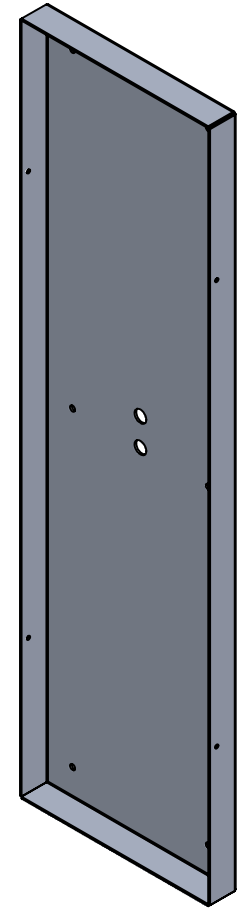
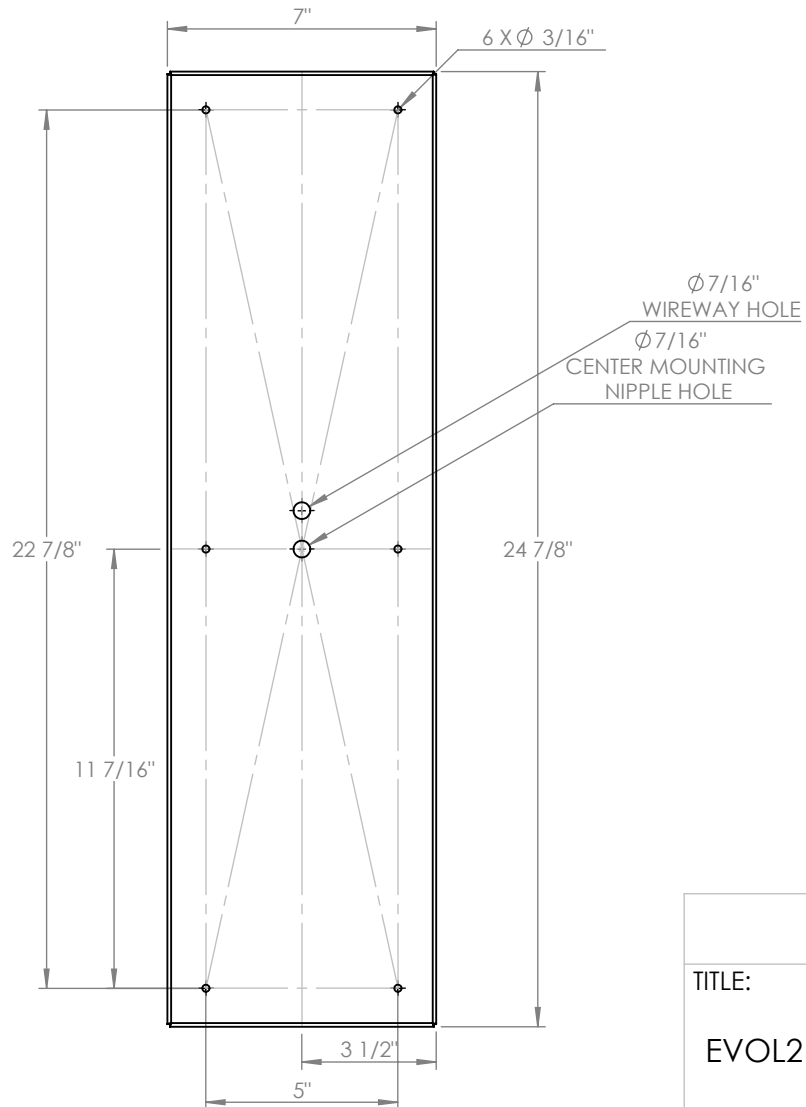
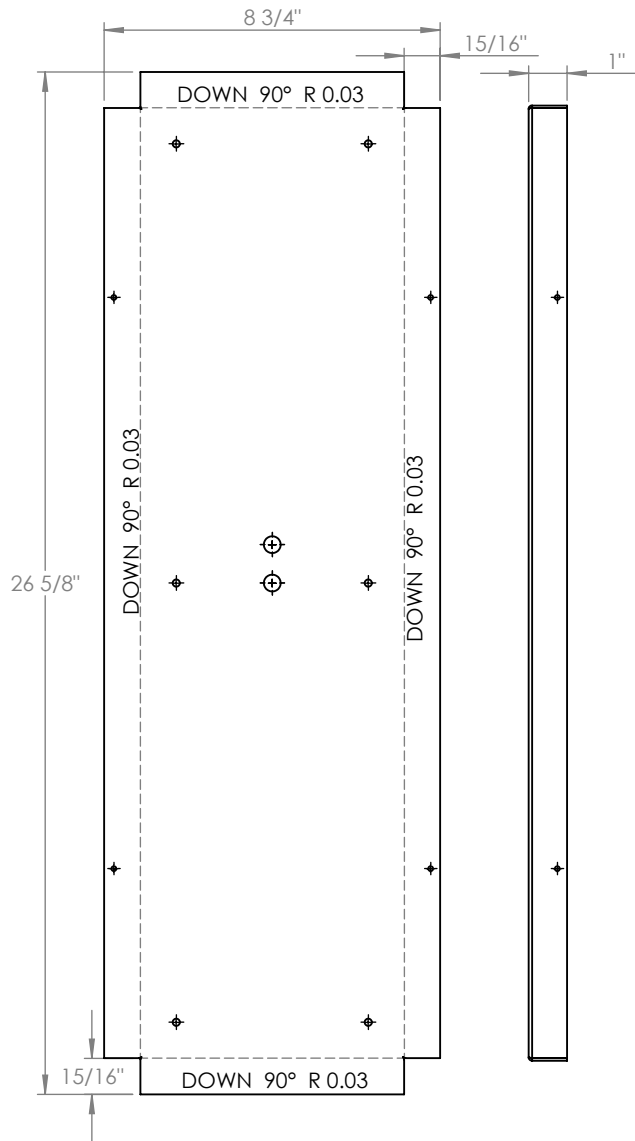

ALUMINUM 0.0635"		
TITLE:		
EVOL21-W-27-224LED-CV-HO-27K		
SIZE	DWG. NO.	REV
A		
SCALE: 1:5	WEIGHT:	SHEET 9 OF 9