

ITEM NO.	PART NUMBER	DESCRIPTION	QTY.	CUT
1	SQ4TABSQ4TAB-SC-18W-MN-WF-DIM-30K-END CAP TRIM	SOFT ALUMINUM 0.125"	2	
2	SQ4TAB-SC-18W-MN-WF-DIM-30K-BACKPLATE	22 GAUGE	1	
3	SQ4TAB-SC-18W-MN-WF-DIM-30K-LED SPACER	22 GAUGE	1	
4	SQ4TAB-SC-18W-MN-WF-DIM-30K-FIREPLATE	22 GAUGE	1	
5	SQ4TAB-SC-18W-MN-WF-DIM-30K-ACRYLIC	ACRYLIC	1	
6	KTLD-25-UV-700-VDIM-LA1	DRIVER	1	
7	AlfaLED_PN1004RevD	LED	2	

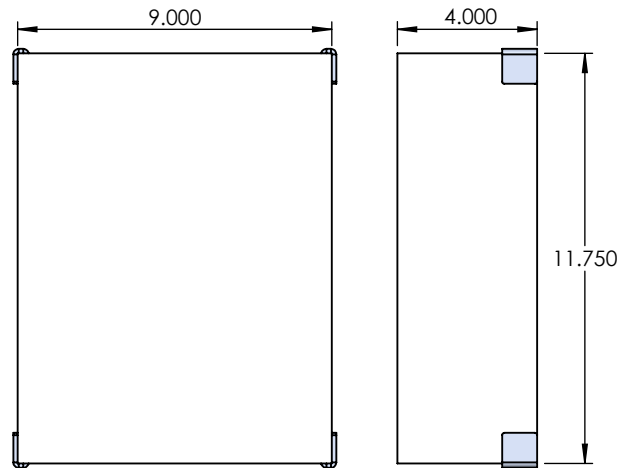
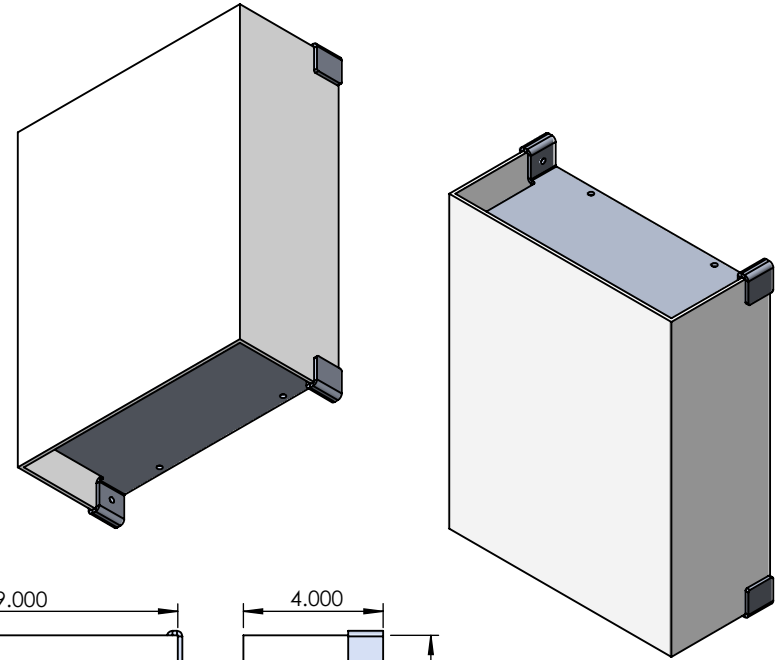
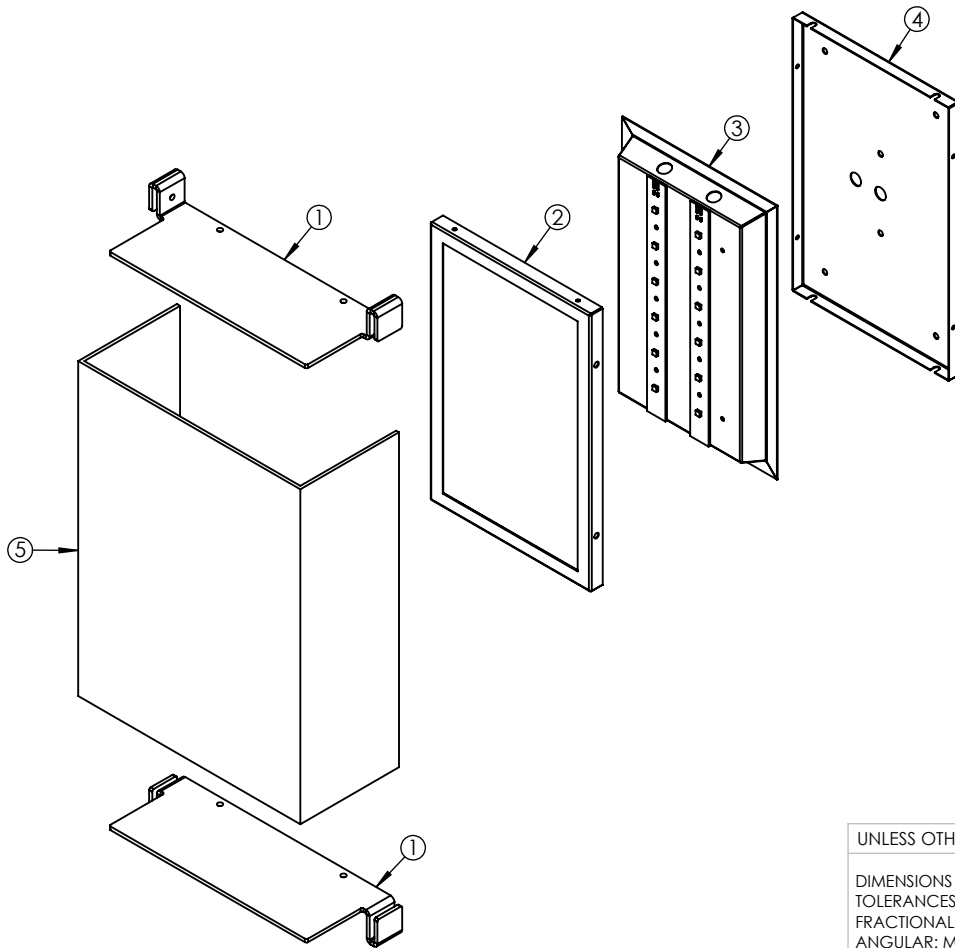

ALL BEND RADIUS .030"

APPLICATION

DO NOT SCALE DRAWING

UNLESS OTHERWISE SPECIFIED:

DIMENSIONS ARE IN INCHES  
TOLERANCES:  
FRACTIONAL  $\pm .003$   
ANGULAR: MACH  $\pm .01$  BEND  $\pm$   
TWO PLACE DECIMAL  $\pm$   
THREE PLACE DECIMAL  $\pm .001$

INTERPRET GEOMETRIC  
TOLERANCING PER:

MATERIAL

FINISH

NAME

DATE

DRAWN

CHECKED

ENG APPR.

MFG APPR.

Q.A.

COMMENTS:

TITLE:

SQ4TAB-SC-18W-MN-WF-DIM-30K

SIZE DWG. NO.

**A** TICKET 26836

REV

SCALE: 1:5.5WEIGHT:

SHEET 1 OF 8

5

4

3

2

1

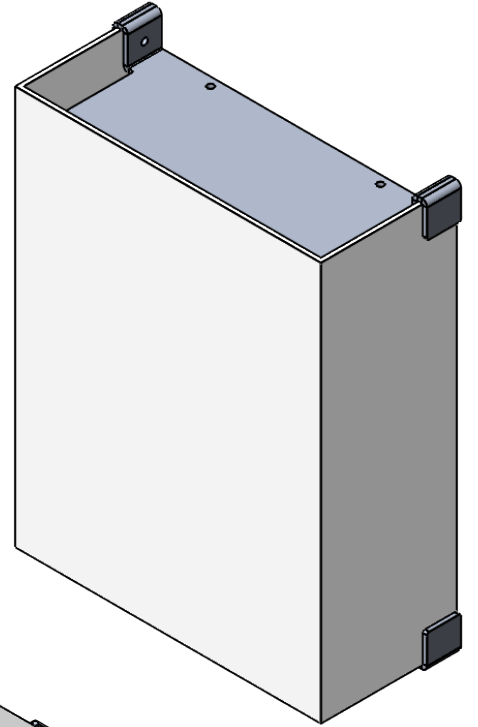
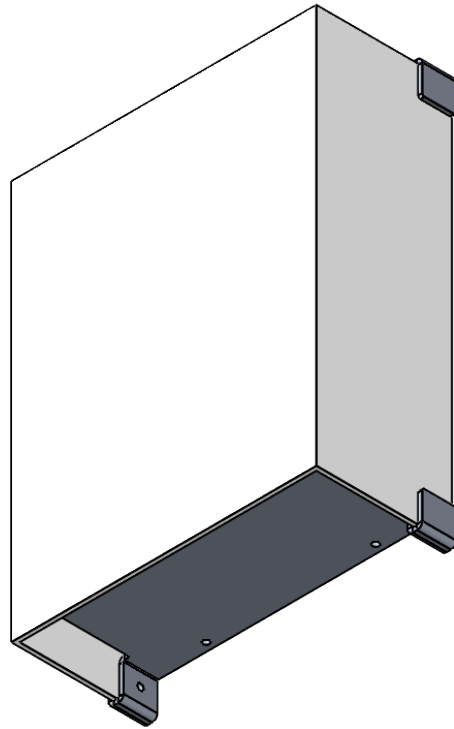
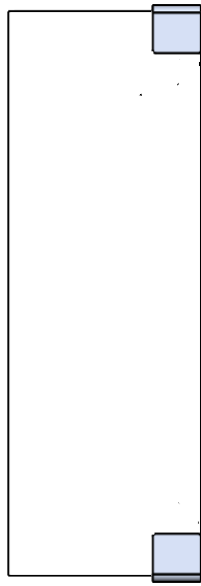
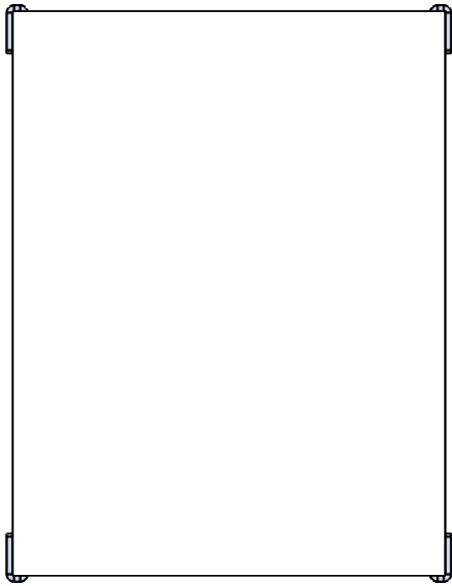
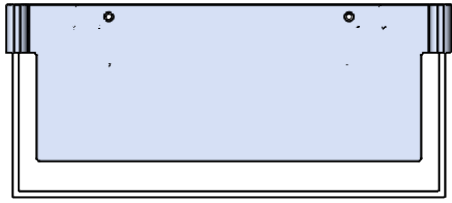

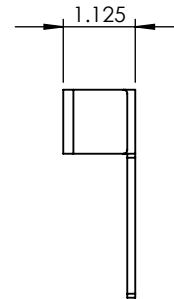
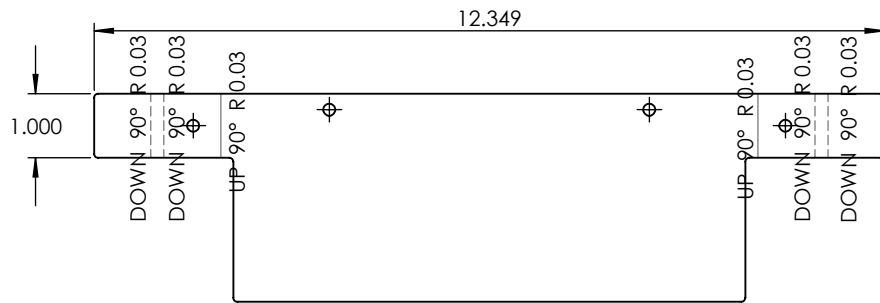
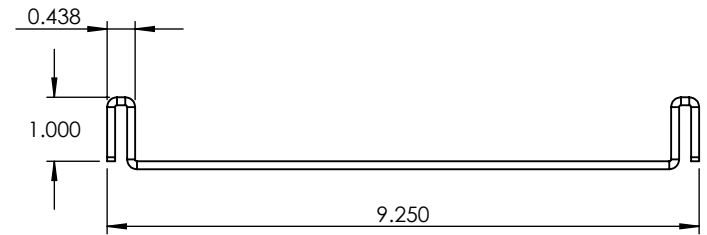
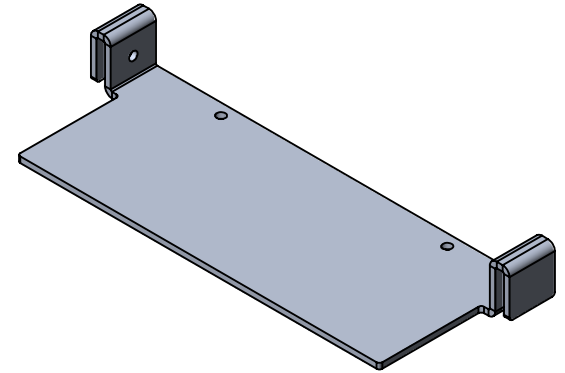
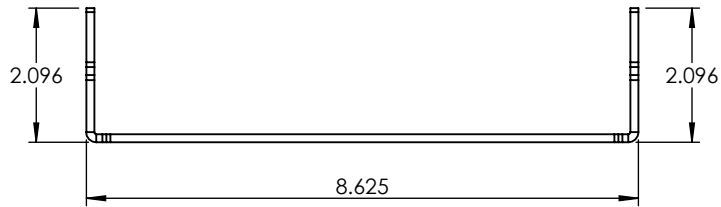
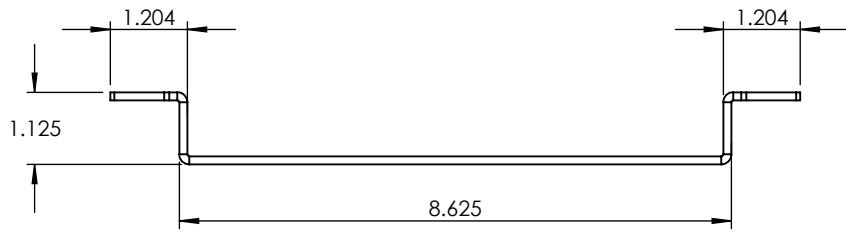

**PROPRIETARY AND CONFIDENTIAL**  
 THE INFORMATION CONTAINED IN THIS DRAWING IS THE SOLE PROPERTY OF <INSERT COMPANY NAME HERE>. ANY REPRODUCTION IN PART OR AS A WHOLE WITHOUT THE WRITTEN PERMISSION OF <INSERT COMPANY NAME HERE> IS PROHIBITED.

		UNLESS OTHERWISE SPECIFIED:		NAME	DATE
		DIMENSIONS ARE IN INCHES	DRAWN		
		TOLERANCES:	CHECKED		
		FRACTIONAL ±	ENG APPR.		
		ANGULAR: MACH ± BEND ±	MFG APPR.		
		TWO PLACE DECIMAL ±	Q.A.		
		THREE PLACE DECIMAL ±	COMMENTS:		
		INTERPRET GEOMETRIC TOLERANCING PER:			
		MATERIAL			
NEXT ASSY	USED ON	FINISH			
APPLICATION		DO NOT SCALE DRAWING			

SOFT ALUMINUM 0.125"		
TITLE:		
SQ4TAB-SC-18W-MN-WF-DIM-30K		
SIZE	DWG. NO.	REV
<b>A</b>		
SCALE: 1:3	WEIGHT:	SHEET 3 OF 8

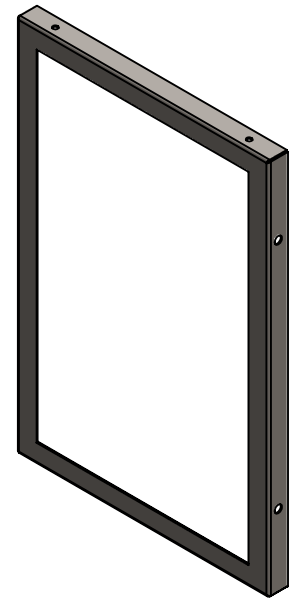
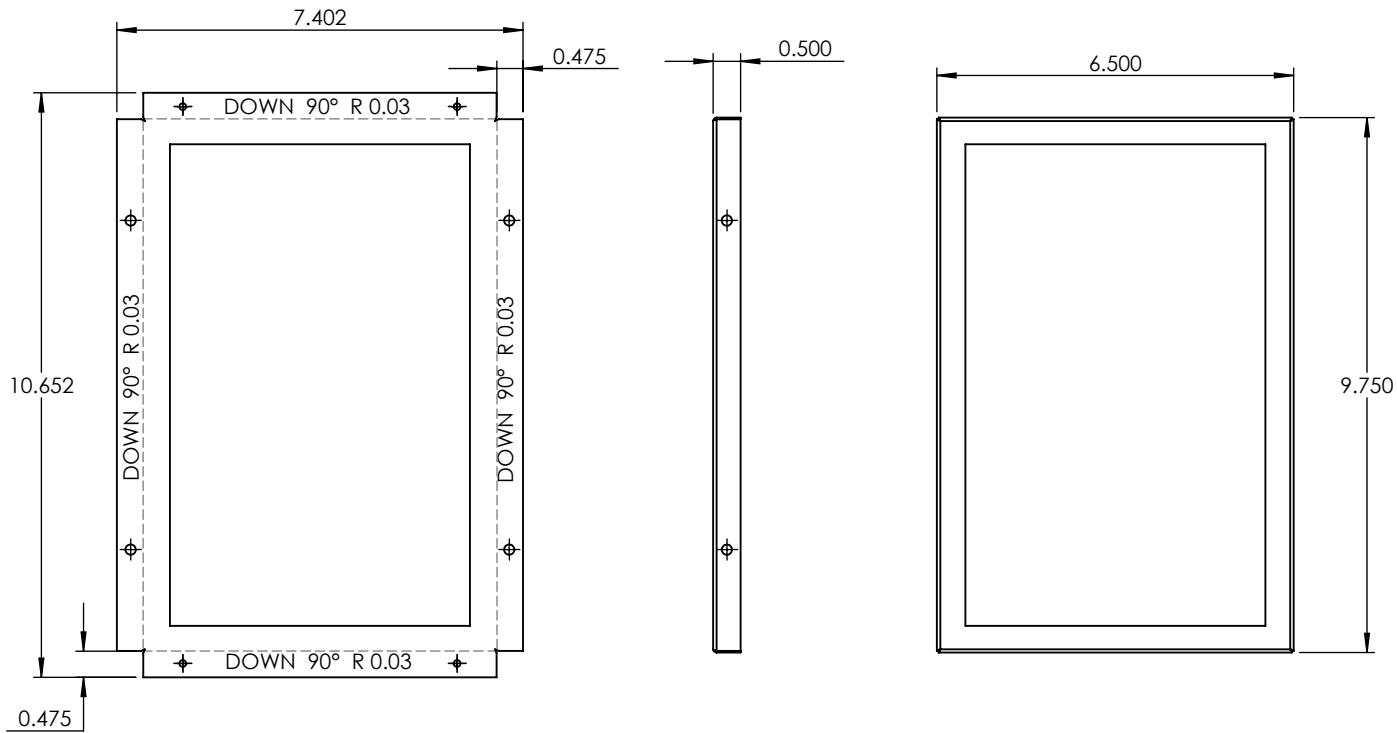

**PROPRIETARY AND CONFIDENTIAL**  
 THE INFORMATION CONTAINED IN THIS DRAWING IS THE SOLE PROPERTY OF <INSERT COMPANY NAME HERE>. ANY REPRODUCTION IN PART OR AS A WHOLE WITHOUT THE WRITTEN PERMISSION OF <INSERT COMPANY NAME HERE> IS PROHIBITED.

		UNLESS OTHERWISE SPECIFIED:	NAME	DATE	22 GAUGE	
		DIMENSIONS ARE IN INCHES TOLERANCES: FRACTIONAL ± ANGULAR: MACH ± BEND ± TWO PLACE DECIMAL ± THREE PLACE DECIMAL ±	DRAWN			
		INTERPRET GEOMETRIC TOLERANCING PER:	CHECKED		SIZE DWG. NO. REV	
		MATERIAL	ENG APPR.			
		FINISH	MFG APPR.			
NEXT ASSY	USED ON		Q.A.			
APPLICATION		DO NOT SCALE DRAWING	COMMENTS:			

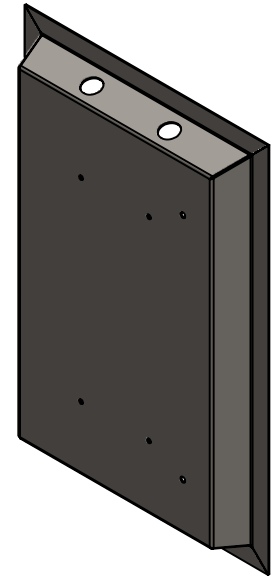
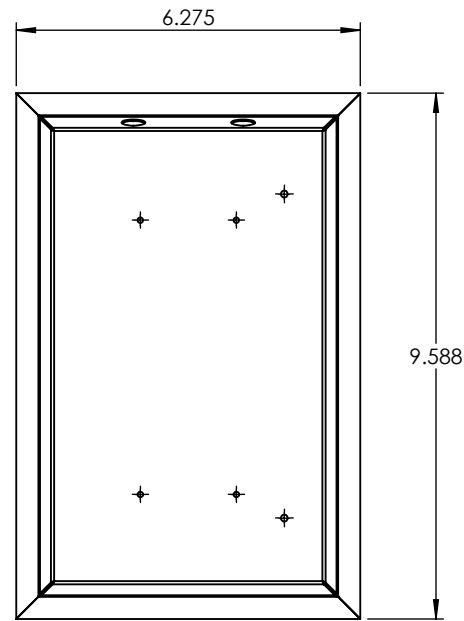
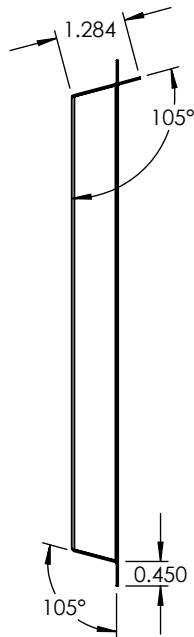
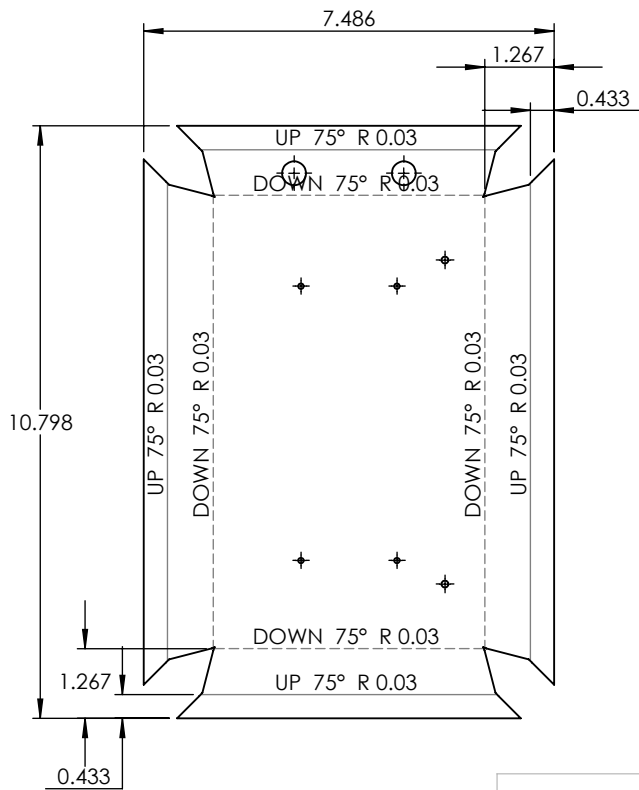

**PROPRIETARY AND CONFIDENTIAL**  
 THE INFORMATION CONTAINED IN THIS DRAWING IS THE SOLE PROPERTY OF <INSERT COMPANY NAME HERE>. ANY REPRODUCTION IN PART OR AS A WHOLE WITHOUT THE WRITTEN PERMISSION OF <INSERT COMPANY NAME HERE> IS PROHIBITED.

		UNLESS OTHERWISE SPECIFIED:	NAME	DATE
		DIMENSIONS ARE IN INCHES	DRAWN	
		TOLERANCES:	CHECKED	
		FRACTIONAL ±	ENG APPR.	
		ANGULAR: MACH ± BEND ±	MFG APPR.	
		TWO PLACE DECIMAL ±	Q.A.	
		THREE PLACE DECIMAL ±	COMMENTS:	
		INTERPRET GEOMETRIC TOLERANCING PER:		
		MATERIAL		
NEXT ASSY	USED ON	FINISH		
APPLICATION		DO NOT SCALE DRAWING		

22 GAUGE		
TITLE:		
SQ4TAB-SC-18W-MN-WF-DIM-30K		
SIZE	DWG. NO.	REV
<b>A</b>		
SCALE: 1:3.5		WEIGHT: SHEET 5 OF 8

5

4

3

2

1

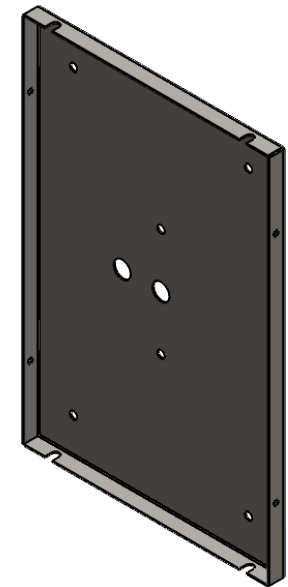
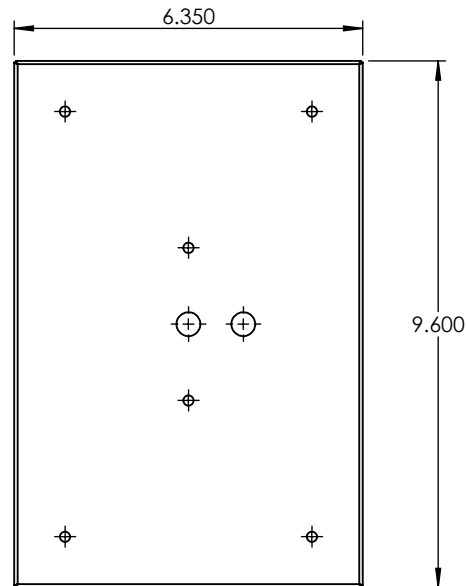
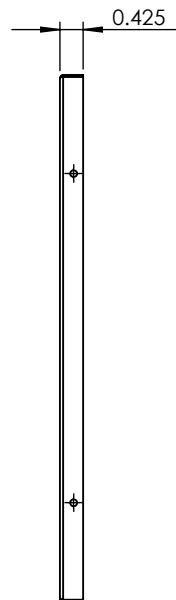
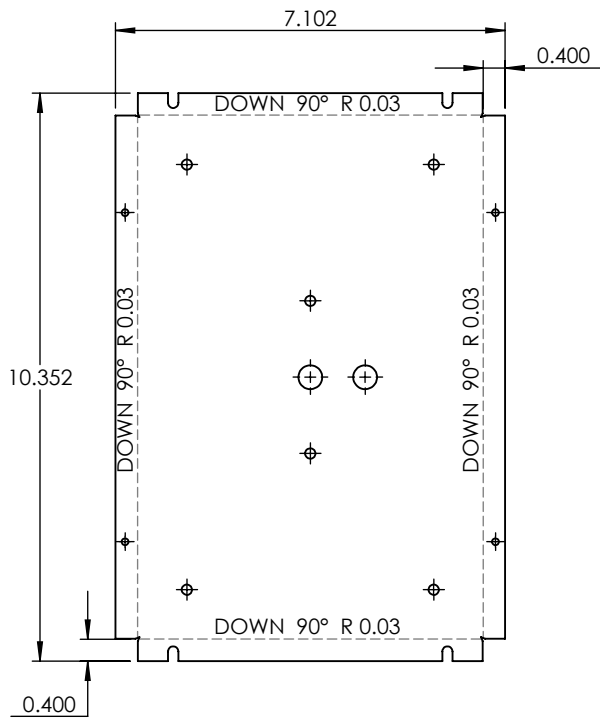

**PROPRIETARY AND CONFIDENTIAL**  
 THE INFORMATION CONTAINED IN THIS DRAWING IS THE SOLE PROPERTY OF <INSERT COMPANY NAME HERE>. ANY REPRODUCTION IN PART OR AS A WHOLE WITHOUT THE WRITTEN PERMISSION OF <INSERT COMPANY NAME HERE> IS PROHIBITED.

		UNLESS OTHERWISE SPECIFIED:		NAME	DATE	<b>22 GAUGE</b>	
		DIMENSIONS ARE IN INCHES TOLERANCES: FRACTIONAL ± ANGULAR: MACH ± BEND ± TWO PLACE DECIMAL ± THREE PLACE DECIMAL ±	DRAWN				
		INTERPRET GEOMETRIC TOLERANCING PER:	CHECKED			<b>SIZE</b> DWG. NO. <b>REV</b>	
		MATERIAL	ENG APPR.				
		FINISH	MFG APPR.			SCALE: 1:3.5 WEIGHT: SHEET 6 OF 8	
NEXT ASSY	USED ON		Q.A.				
APPLICATION		DO NOT SCALE DRAWING	COMMENTS:				

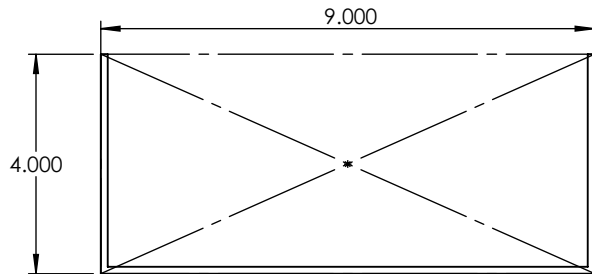
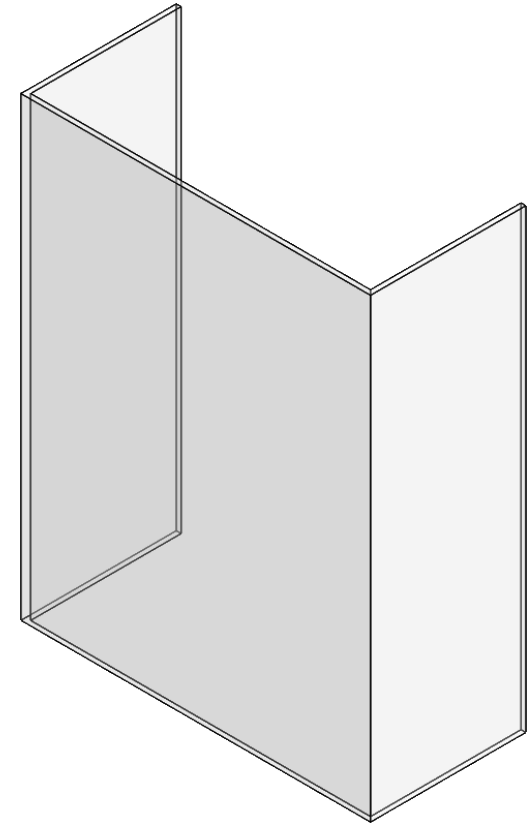
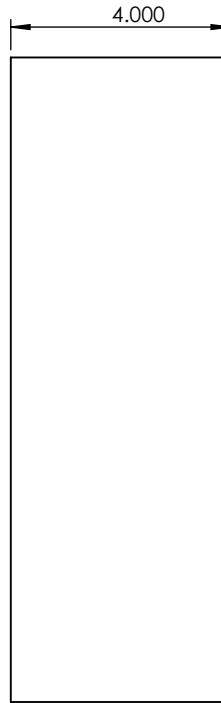
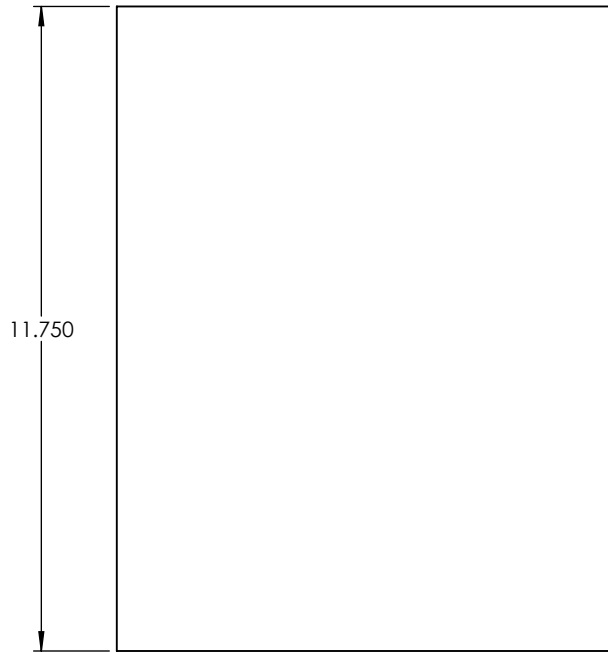

UNLESS OTHERWISE SPECIFIED:		NAME	DATE	ACRYLIC	
DIMENSIONS ARE IN INCHES		DRAWN			
TOLERANCES:		CHECKED			
FRACTIONAL ±		ENG APPR.			
ANGULAR: MACH ± BEND ±		MFG APPR.			
TWO PLACE DECIMAL ±		Q.A.		SIZE DWG. NO. REV	
THREE PLACE DECIMAL ±		COMMENTS:			
INTERPRET GEOMETRIC TOLERANCING PER:				SCALE: 1:3.5	WEIGHT:
MATERIAL				SHEET 7 OF 8	
FINISH					
DO NOT SCALE DRAWING					

**PROPRIETARY AND CONFIDENTIAL**  
 THE INFORMATION CONTAINED IN THIS DRAWING IS THE SOLE PROPERTY OF <INSERT COMPANY NAME HERE>. ANY REPRODUCTION IN PART OR AS A WHOLE WITHOUT THE WRITTEN PERMISSION OF <INSERT COMPANY NAME HERE> IS PROHIBITED.

NEXT ASSY	USED ON
APPLICATION	

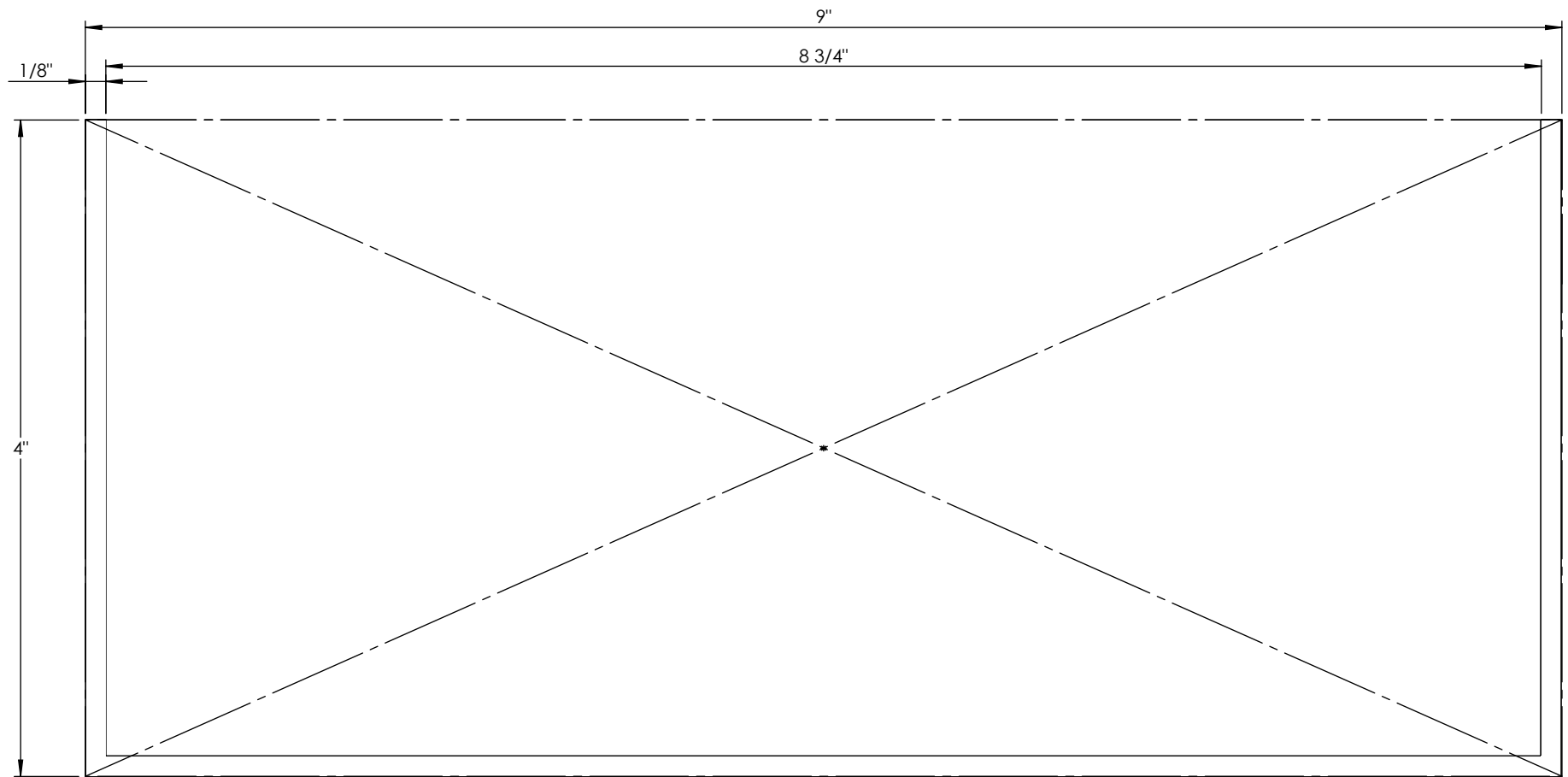

**PROPRIETARY AND CONFIDENTIAL**  
 THE INFORMATION CONTAINED IN THIS DRAWING IS THE SOLE PROPERTY OF <INSERT COMPANY NAME HERE>. ANY REPRODUCTION IN PART OR AS A WHOLE WITHOUT THE WRITTEN PERMISSION OF <INSERT COMPANY NAME HERE> IS PROHIBITED.

		UNLESS OTHERWISE SPECIFIED:		NAME	DATE	ACRYLIC	
		DIMENSIONS ARE IN INCHES TOLERANCES: FRACTIONAL ± ANGULAR: MACH ± BEND ± TWO PLACE DECIMAL ± THREE PLACE DECIMAL ±	DRAWN				
		INTERPRET GEOMETRIC TOLERANCING PER:	CHECKED			SQ4TAB-SC-18W-MN-WF-DIM-30K	
		MATERIAL	ENG APPR.			SIZE DWG. NO. REV	
	NEXT ASSY	USED ON	MFG APPR.			A	
		FINISH	Q.A.			SCALE: 1:1 WEIGHT: SHEET 8 OF 8	
	APPLICATION	DO NOT SCALE DRAWING	COMMENTS:				

5

4

3

2

1