

ITEM NO.	PART NUMBER	DESCRIPTION	QTY.	CUT
1	WLBWL-20-50W-MN-WF-DIM-35K-SPUN CANOPY	SPUN ALUMINUM 0.125"	1	
2	WLBWL-20-50W-MN-WF-DIM-35K-SPUN FIREPLATE	SPUN ALUMINUM 0.125"	1	
3	WLBWL-20-50W-MN-WF-DIM-35K-SPUN SPHERE	SPUN ALUMINUM 0.080"	1	
4	WLBWL-20-50W-MN-WF-DIM-35K-SPUN DOOR	SPUN ALUMINUM 0.080"	1	
5	WLBWL-20-50W-MN-WF-DIM-35K-SPUN DOOR BRACKET	SPUN ALUMINUM 0.080"	1	
6	WLBWL-20-50W-MN-WF-DIM-35K-ARM COVER	SPUN ALUMINUM 0.0635"	1	
7	WLBWL-20-50W-MN-WF-DIM-35K-CANOPY BRACKET	ALUMINUM 0.500" PLATE	1	
8	WLBWL-20-50W-MN-WF-DIM-35K-0.250" NUT	ALUMINUM 0.250" PLATE	1	
9	WLBWL-20-50W-MN-WF-DIM-35K-3" CYLINDER CAP	ALUMINUM 0.250" PLATE	1	
10	WLBWL-20-50W-MN-WF-DIM-35K-DRIVER BRACKET	ALUMINUM 0.0635"	1	
11	WLBWL-20-50W-MN-WF-DIM-35K-LED PLATE	ALUMINUM 0.0635"	1	
12	WLBWL-20-50W-MN-WF-DIM-35K-LED PLATE BRACKET	ALUMINUM 0.0635"	1	
13	WLBWL-20-50W-MN-WF-DIM-35K-1.500" ARM TUBE	1-1/2" ALUMINUM TUBE	1	
14	WLBWL-20-50W-MN-WF-DIM-35K-3" CYLINDER POST	3" ALUMINUM TUBE	1	
15	WLBWL-20-50W-MN-WF-DIM-35K-ACRYLIC LENS	ACRYLIC	1	
16	KTLD-25-UV-700-VDIM-LA1	DRIVER	2	
17	AltLED_PN110B_RevC	LED	4	

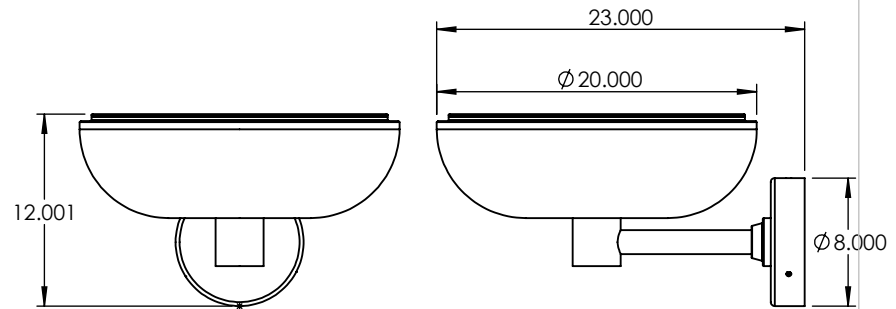
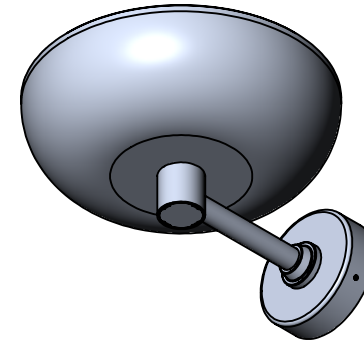
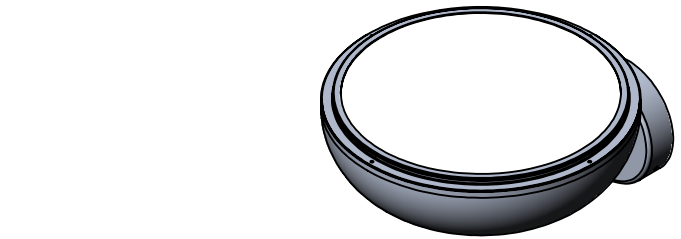
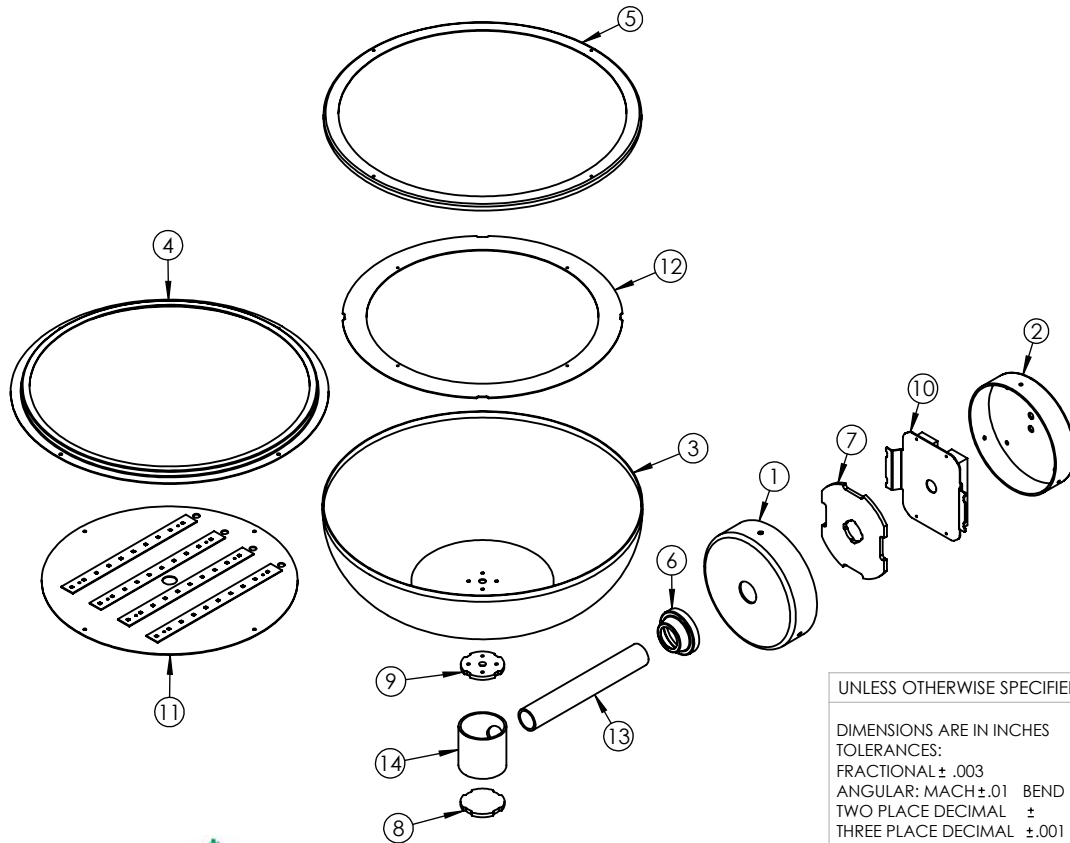

ALL BEND RADIUS .030"

APPLICATION

DO NOT SCALE DRAWING

UNLESS OTHERWISE SPECIFIED:

DIMENSIONS ARE IN INCHES
TOLERANCES:
FRACTIONAL ± .003
ANGULAR: MACH ± .01 BEND ±
TWO PLACE DECIMAL ±
THREE PLACE DECIMAL ± .001

INTERPRET GEOMETRIC
TOLERANCING PER:

MATERIAL

FINISH

NAME DATE

DRAWN
CHECKED
ENG APPR.
MFG APPR.

Q.A.
COMMENTS:

TITLE:

WLBWL-20-50W-MN-WF-DIM-35K

SIZE DWG. NO. REV

A TICKET 26876

SCALE: 1:12 WEIGHT:

SHEET 1 OF 11

5

4

3

2

1

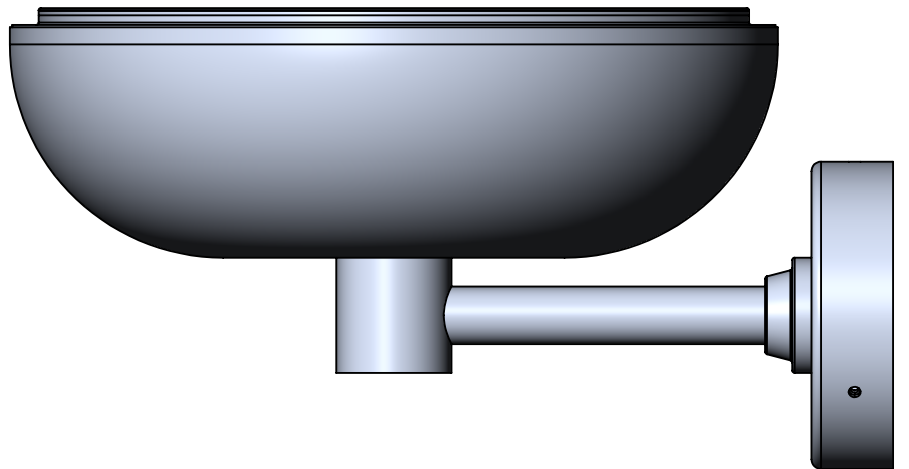
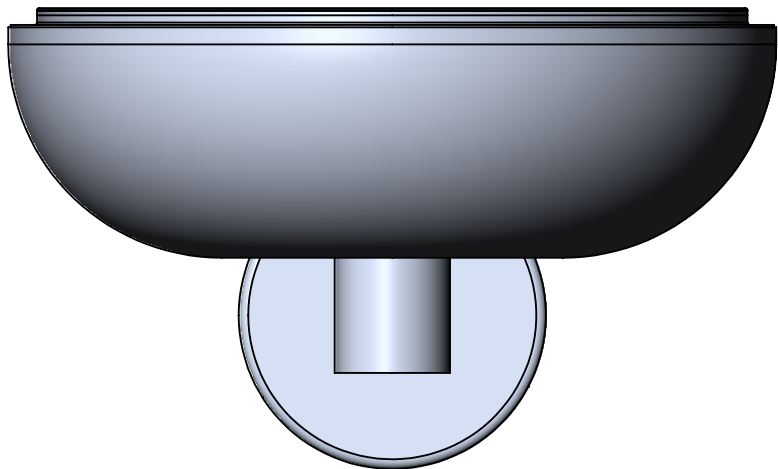
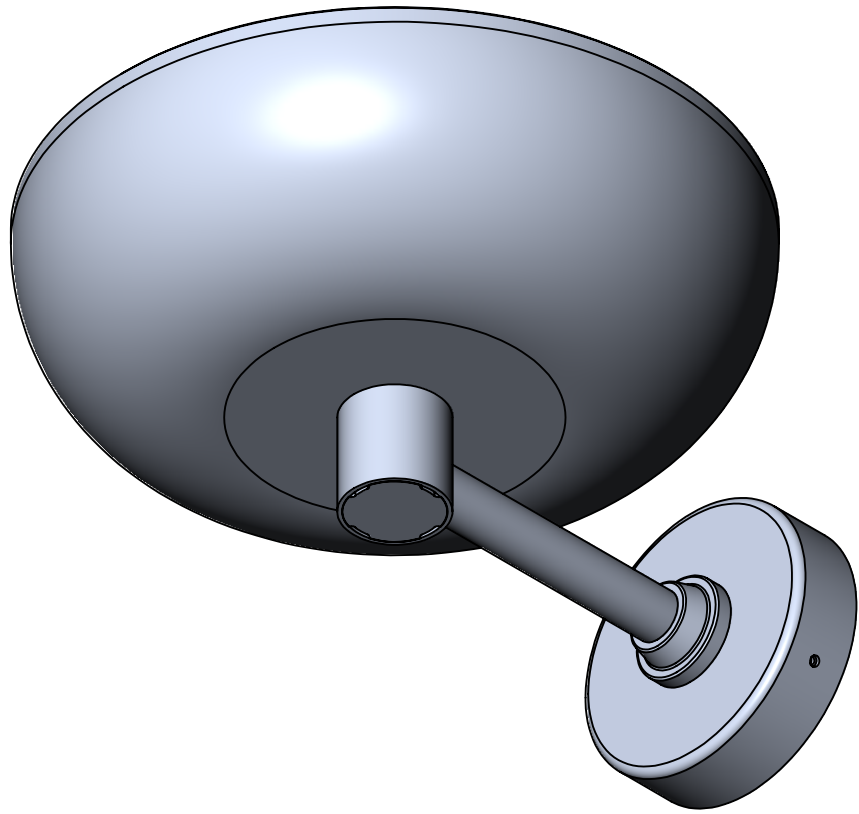

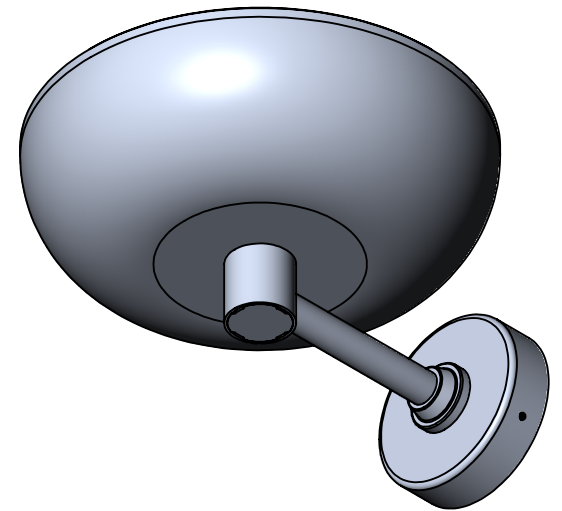
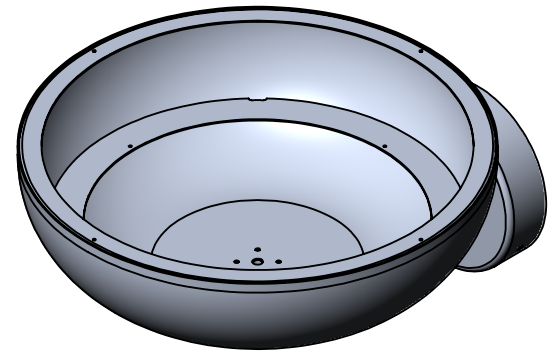
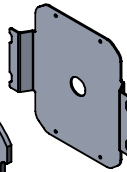
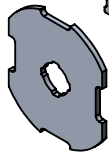
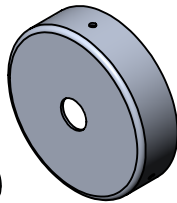
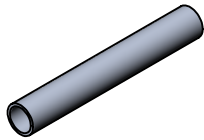
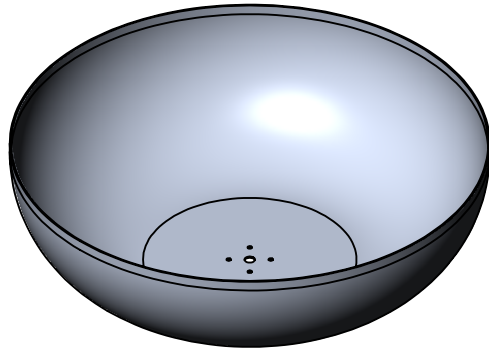
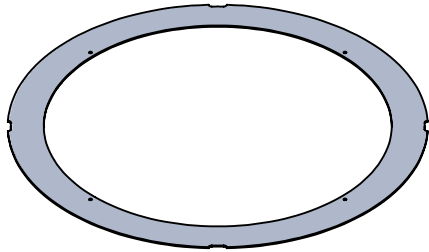
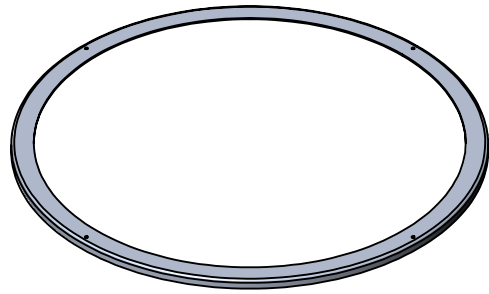

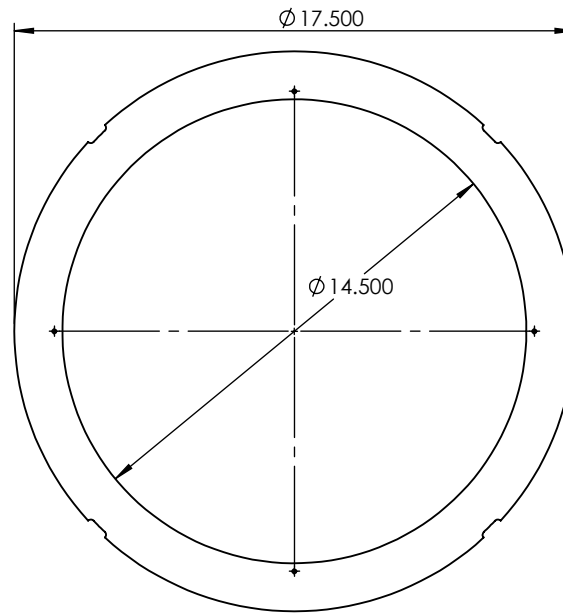
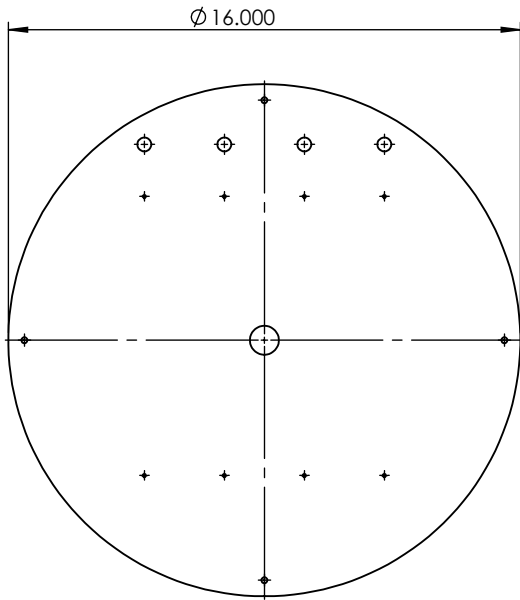
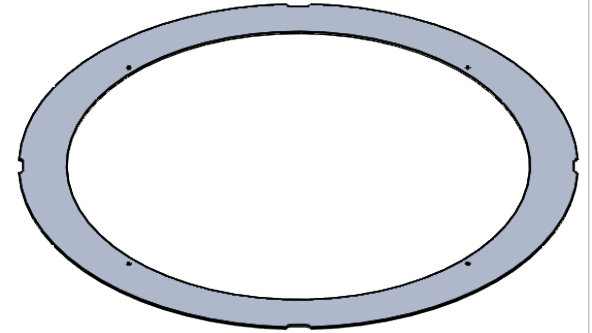
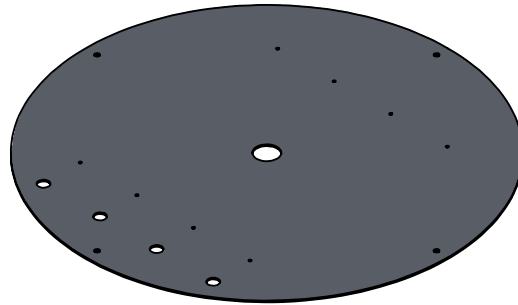

PROPRIETARY AND CONFIDENTIAL
 THE INFORMATION CONTAINED IN THIS DRAWING IS THE SOLE PROPERTY OF <INSERT COMPANY NAME HERE>. ANY REPRODUCTION IN PART OR AS A WHOLE WITHOUT THE WRITTEN PERMISSION OF <INSERT COMPANY NAME HERE> IS PROHIBITED.

		UNLESS OTHERWISE SPECIFIED:		NAME	DATE
		DIMENSIONS ARE IN INCHES	DRAWN		
		TOLERANCES:	CHECKED		
		FRACTIONAL ±	ENG APPR.		
		ANGULAR: MACH ± BEND ±	MFG APPR.		
		TWO PLACE DECIMAL ±	Q.A.		
		THREE PLACE DECIMAL ±	COMMENTS:		
		INTERPRET GEOMETRIC TOLERANCING PER:			
		MATERIAL			
	NEXT ASSY	FINISH			
	USED ON				
	APPLICATION	DO NOT SCALE DRAWING			

ALUMINUM 0.0635"		
TITLE:		
WLBWL-20-50W-MN-WF-DIM-35K		
SIZE	DWG. NO.	REV
A		
SCALE: 1:6	WEIGHT:	SHEET 4 OF 11

ITEM NO.	PART NUMBER	DESCRIPTION	QTY.
1	WLBWL-20-50W-MN-WF-DIM-35K-SPUN SPHERE	SPUN ALUMINUM 0.080"	1

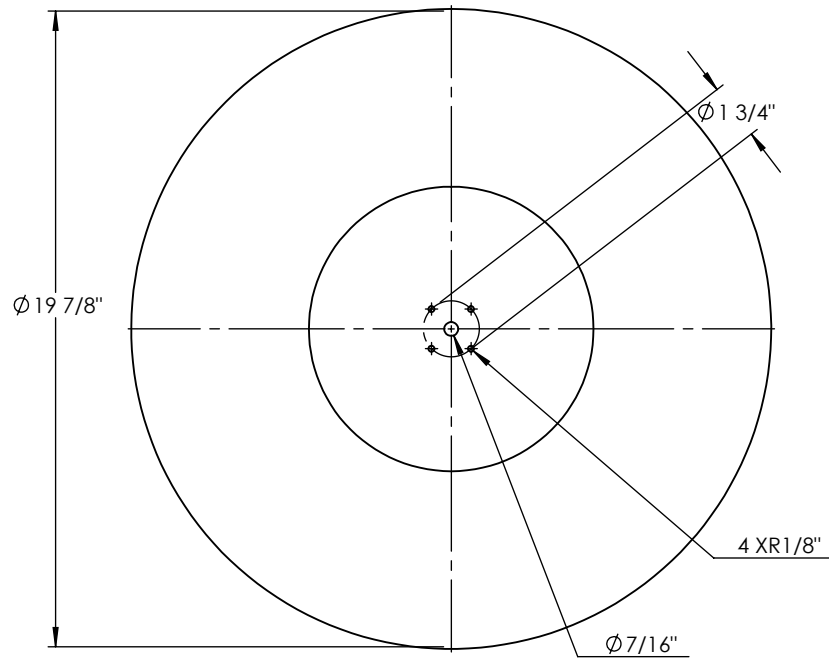
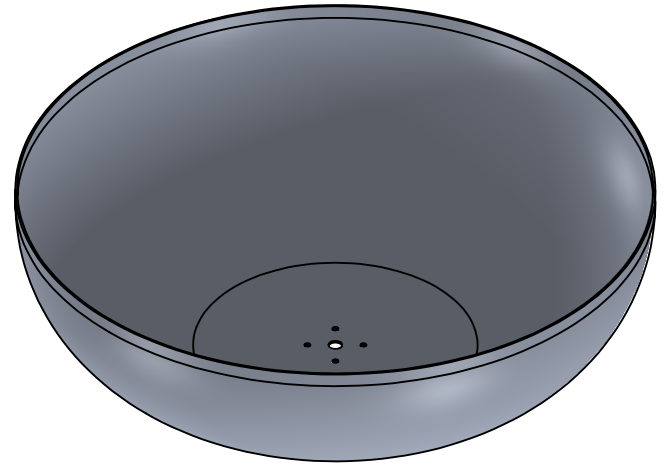
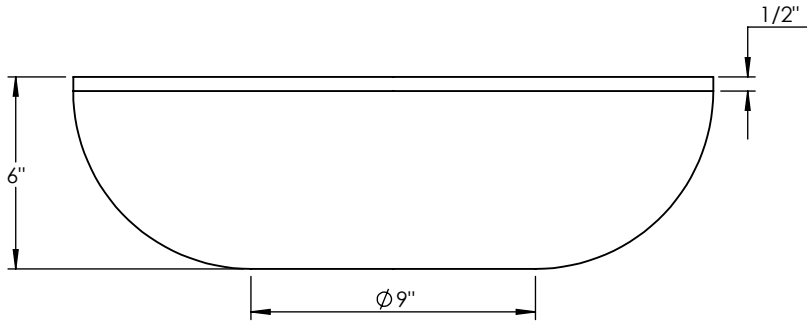

PROPRIETARY AND CONFIDENTIAL
 THE INFORMATION CONTAINED IN THIS DRAWING IS THE SOLE PROPERTY OF <INSERT COMPANY NAME HERE>. ANY REPRODUCTION IN PART OR AS A WHOLE WITHOUT THE WRITTEN PERMISSION OF <INSERT COMPANY NAME HERE> IS PROHIBITED.

		UNLESS OTHERWISE SPECIFIED:	NAME	DATE
		DIMENSIONS ARE IN INCHES TOLERANCES: FRACTIONAL ± ANGULAR: MACH ± BEND ± TWO PLACE DECIMAL ± THREE PLACE DECIMAL ±	DRAWN	
		INTERPRET GEOMETRIC TOLERANCING PER:	CHECKED	
		MATERIAL	ENG APPR.	
		FINISH	MFG APPR.	
NEXT ASSY	USED ON		Q.A.	
APPLICATION		DO NOT SCALE DRAWING	COMMENTS:	

SPUN ALUMINUM 0.080"		
TITLE:		
WLBWL-20-50W-MN-WF-DIM-35K		
SIZE	DWG. NO.	REV
A		
SCALE: 1:6	WEIGHT:	SHEET 5 OF 11

ITEM NO.	PART NUMBER	DESCRIPTION	QTY.
1	WLBWL-20-50W-MN-WF-DIM-35K-SPUN DOOR	SPUN ALUMINUM 0.080"	1

ITEM NO.	PART NUMBER	DESCRIPTION	QTY.
1	WLBWL-20-50W-MN-WF-DIM-35K-SPUN DOOR BRACKET	SPUN ALUMINUM 0.080"	1

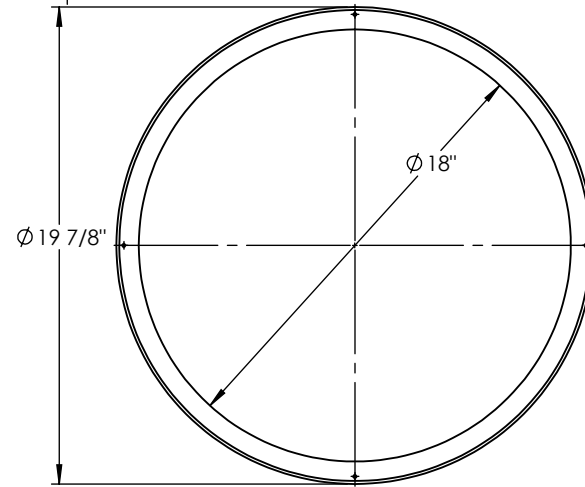
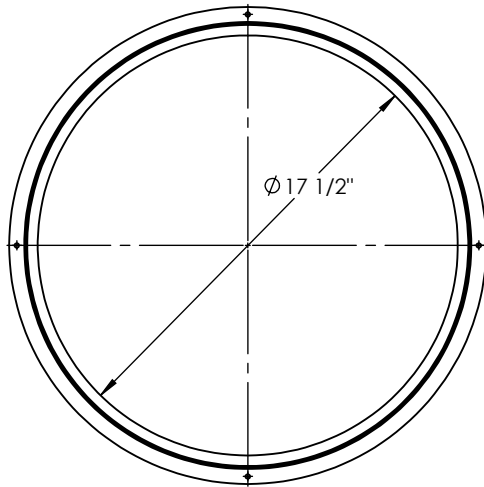
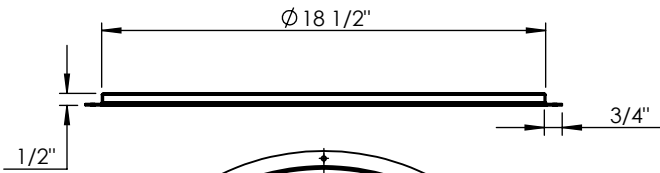
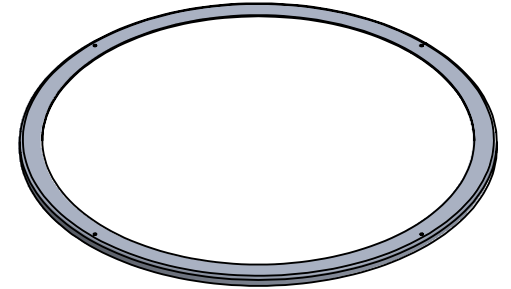
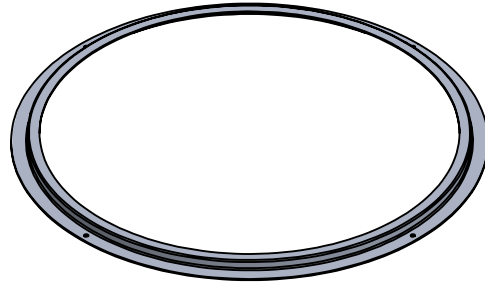

PROPRIETARY AND CONFIDENTIAL
 THE INFORMATION CONTAINED IN THIS DRAWING IS THE SOLE PROPERTY OF <INSERT COMPANY NAME HERE>. ANY REPRODUCTION IN PART OR AS A WHOLE WITHOUT THE WRITTEN PERMISSION OF <INSERT COMPANY NAME HERE> IS PROHIBITED.

		UNLESS OTHERWISE SPECIFIED:	NAME	DATE
		DIMENSIONS ARE IN INCHES TOLERANCES: FRACTIONAL ± ANGULAR: MACH ± BEND ± TWO PLACE DECIMAL ± THREE PLACE DECIMAL ±	DRAWN	
		INTERPRET GEOMETRIC TOLERANCING PER:	CHECKED	
		MATERIAL	ENG APPR.	
		FINISH	MFG APPR.	
			Q.A.	
			COMMENTS:	
NEXT ASSY	USED ON			
APPLICATION		DO NOT SCALE DRAWING		

SPUN ALUMINUM 0.080"

TITLE:

WLBWL-20-50W-MN-WF-DIM-35K

SIZE	DWG. NO.	REV
A		

SCALE: 1:8	WEIGHT:	SHEET 6 OF 11
------------	---------	---------------

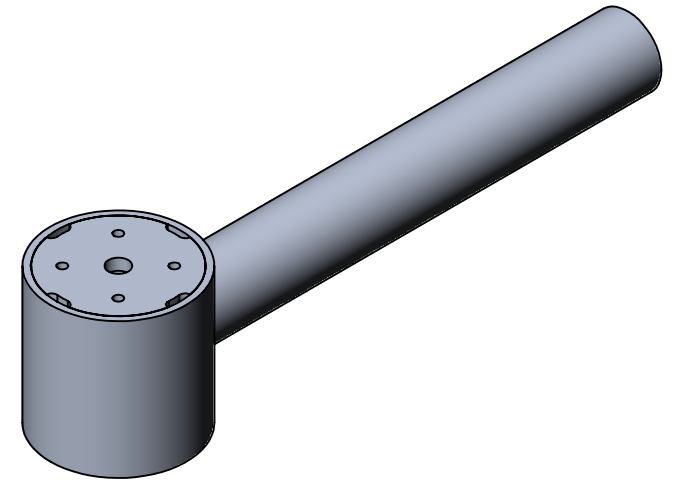
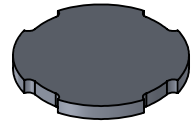
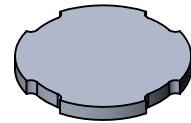
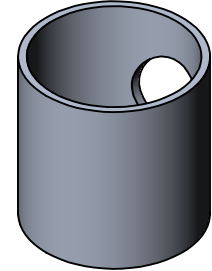
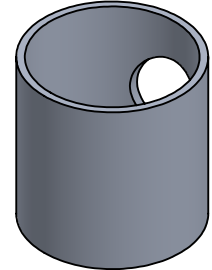
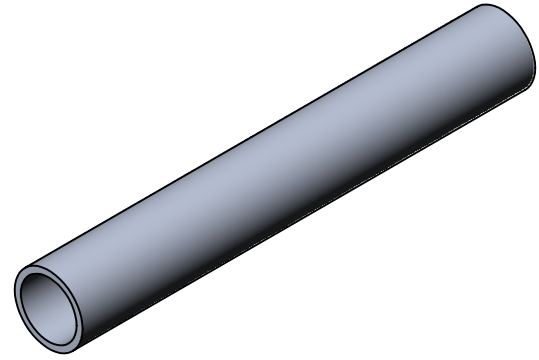
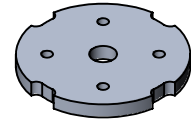
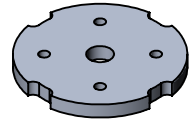
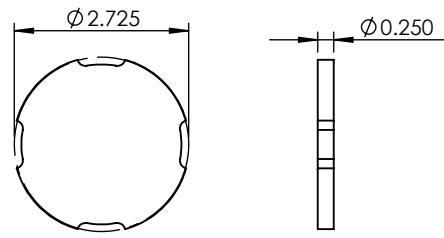
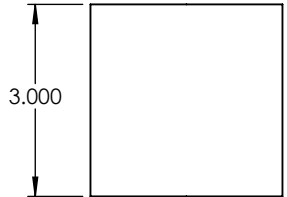
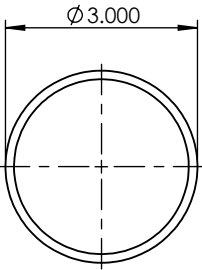
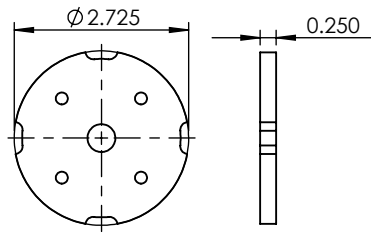

PROPRIETARY AND CONFIDENTIAL
 THE INFORMATION CONTAINED IN THIS DRAWING IS THE SOLE PROPERTY OF <INSERT COMPANY NAME HERE>. ANY REPRODUCTION IN PART OR AS A WHOLE WITHOUT THE WRITTEN PERMISSION OF <INSERT COMPANY NAME HERE> IS PROHIBITED.

NEXT ASSY	USED ON
APPLICATION	

UNLESS OTHERWISE SPECIFIED:
DIMENSIONS ARE IN INCHES
TOLERANCES:
FRACTIONAL ±
ANGULAR: MACH ± BEND ±
TWO PLACE DECIMAL ±
THREE PLACE DECIMAL ±
INTERPRET GEOMETRIC TOLERANCING PER:
MATERIAL
FINISH
DO NOT SCALE DRAWING

NAME	DATE
DRAWN	
CHECKED	
ENG APPR.	
MFG APPR.	
Q.A.	
COMMENTS:	

3" ALUMINUM TUBE		
TITLE:		
WLBWL-20-50W-MN-WF-DIM-35K		
SIZE	DWG. NO.	REV
A		
SCALE: 1:3	WEIGHT:	SHEET 7 OF 11

5

4

3

2

1

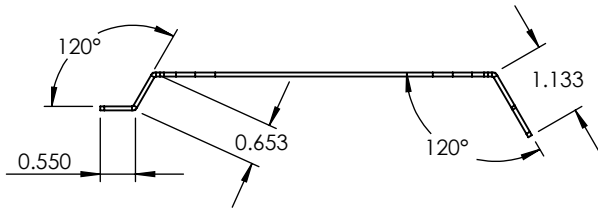
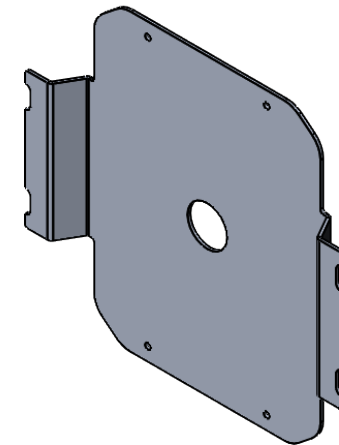
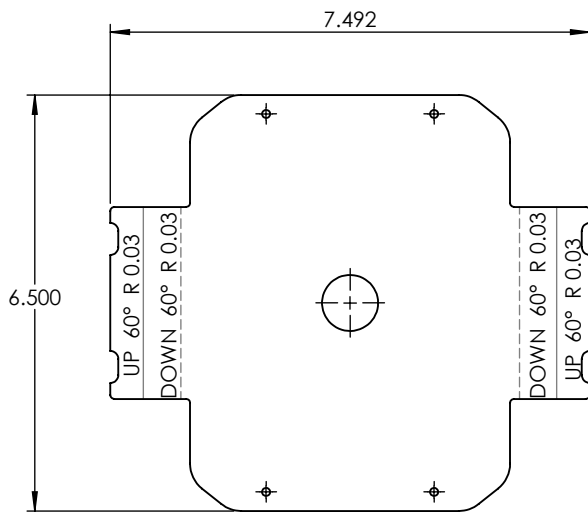

PROPRIETARY AND CONFIDENTIAL
 THE INFORMATION CONTAINED IN THIS DRAWING IS THE SOLE PROPERTY OF <INSERT COMPANY NAME HERE>. ANY REPRODUCTION IN PART OR AS A WHOLE WITHOUT THE WRITTEN PERMISSION OF <INSERT COMPANY NAME HERE> IS PROHIBITED.

		UNLESS OTHERWISE SPECIFIED:		NAME	DATE	ALUMINUM 0.0635"	
		DIMENSIONS ARE IN INCHES	DRAWN			TITLE:	
		TOLERANCES:	CHECKED			WLBWL-20-50W-MN-WF-DIM-35K	
		FRACTIONAL ±	ENG APPR.			SIZE DWG. NO. REV	
		ANGULAR: MACH ± BEND ±	MFG APPR.			A	
		TWO PLACE DECIMAL ±	Q.A.			SCALE: 1:3 WEIGHT: SHEET 8 OF 11	
		THREE PLACE DECIMAL ±	COMMENTS:				
		INTERPRET GEOMETRIC TOLERANCING PER:					
		MATERIAL					
	NEXT ASSY	USED ON					
		FINISH					
	APPLICATION	DO NOT SCALE DRAWING					

ITEM NO.	PART NUMBER	DESCRIPTION	QTY.
1	LH20LED-LV-WH-ARM-8"CNPY-40K-ARM COVER	SPUN ALUMINUM 0.0635"	1

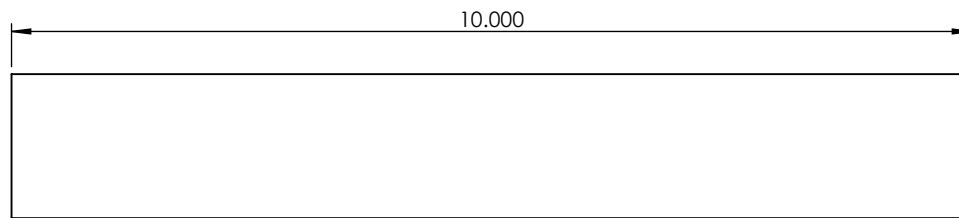
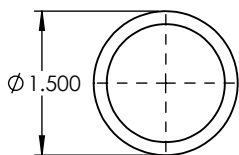
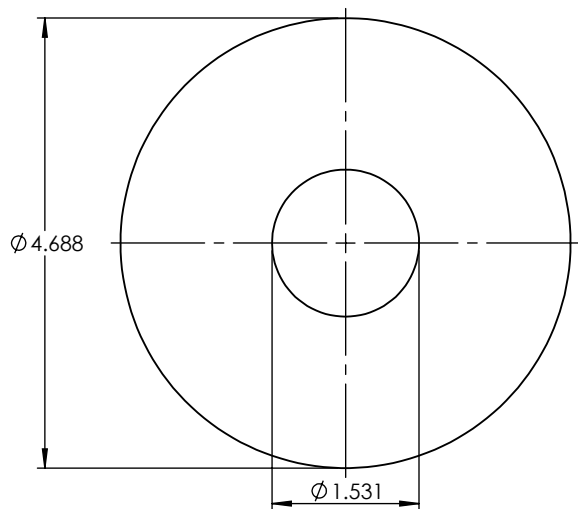
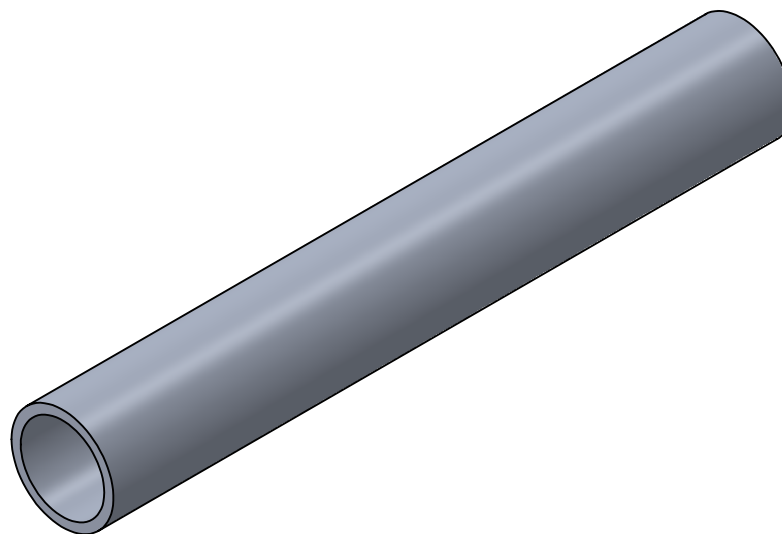
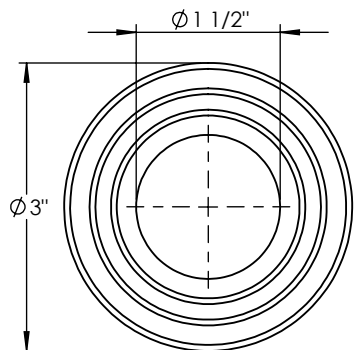
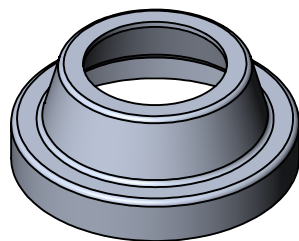
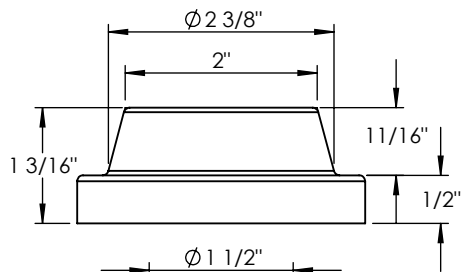

UNLESS OTHERWISE SPECIFIED:		NAME	DATE
DIMENSIONS ARE IN INCHES		DRAWN	
TOLERANCES:		CHECKED	
FRACTIONAL ±		ENG APPR.	
ANGULAR: MACH ± BEND ±		MFG APPR.	
TWO PLACE DECIMAL ±		Q.A.	
THREE PLACE DECIMAL ±		COMMENTS:	
INTERPRET GEOMETRIC TOLERANCING PER:			
MATERIAL			
FINISH			
NEXT ASSY	USED ON		
APPLICATION	DO NOT SCALE DRAWING		

SPUN ALUMINUM 0.0635"		
TITLE:		
WLBWL-20-50W-MN-WF-DIM-35K		
SIZE	DWG. NO.	REV
A		
SCALE: 1:2	WEIGHT:	SHEET 9 OF 11

PROPRIETARY AND CONFIDENTIAL
 THE INFORMATION CONTAINED IN THIS DRAWING IS THE SOLE PROPERTY OF <INSERT COMPANY NAME HERE>. ANY REPRODUCTION IN PART OR AS A WHOLE WITHOUT THE WRITTEN PERMISSION OF <INSERT COMPANY NAME HERE> IS PROHIBITED.

ITEM NO.	PART NUMBER	DESCRIPTION	QTY.
1	WLBWL-20-50W-MN-WF-DIM-35K-SPUN CANOPY	SPUN ALUMINUM 0.125"	1

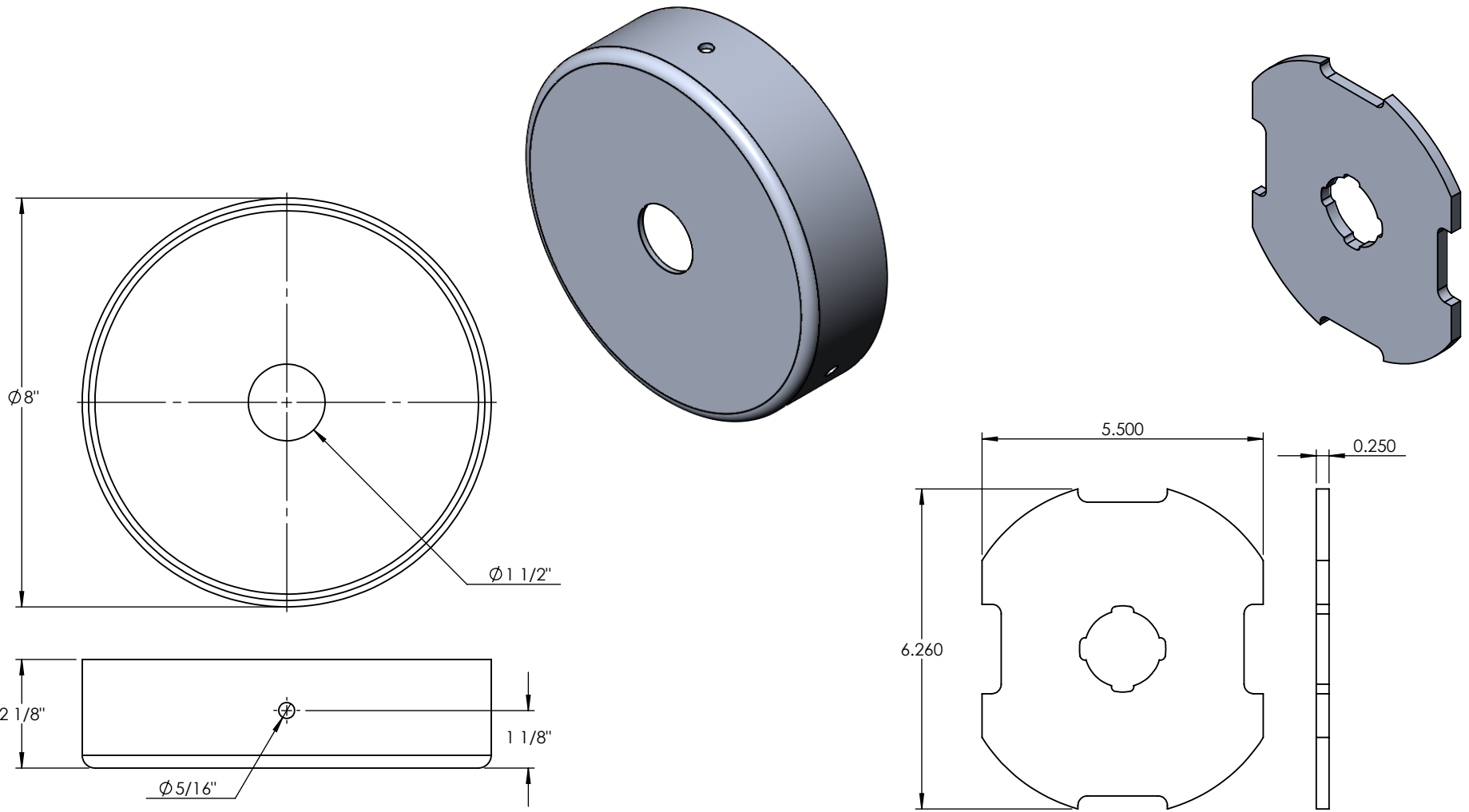

PROPRIETARY AND CONFIDENTIAL
 THE INFORMATION CONTAINED IN THIS DRAWING IS THE SOLE PROPERTY OF <INSERT COMPANY NAME HERE>. ANY REPRODUCTION IN PART OR AS A WHOLE WITHOUT THE WRITTEN PERMISSION OF <INSERT COMPANY NAME HERE> IS PROHIBITED.

		UNLESS OTHERWISE SPECIFIED:		NAME	DATE
		DIMENSIONS ARE IN INCHES		DRAWN	
		TOLERANCES:		CHECKED	
		FRACTIONAL ±		ENG APPR.	
		ANGULAR: MACH ± BEND ±		MFG APPR.	
		TWO PLACE DECIMAL ±		Q.A.	
		THREE PLACE DECIMAL ±		COMMENTS:	
		INTERPRET GEOMETRIC TOLERANCING PER:			
		MATERIAL			
		FINISH			
NEXT ASSY	USED ON				
APPLICATION		DO NOT SCALE DRAWING			

SPUN ALUMINUM 0.125"		
TITLE:		
WLBWL-20-50W-MN-WF-DIM-35K		
SIZE	DWG. NO.	REV
A		
SCALE: 1:3	WEIGHT:	SHEET 10 OF 11

ITEM NO.	PART NUMBER	DESCRIPTION	QTY.
1	WLBWL-20-50W-MN-WF-DIM-35K-SPUN FIREPLATE	SPUN ALUMINUM 0.125"	1

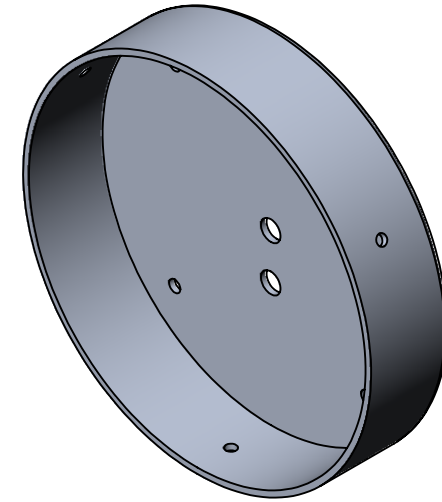
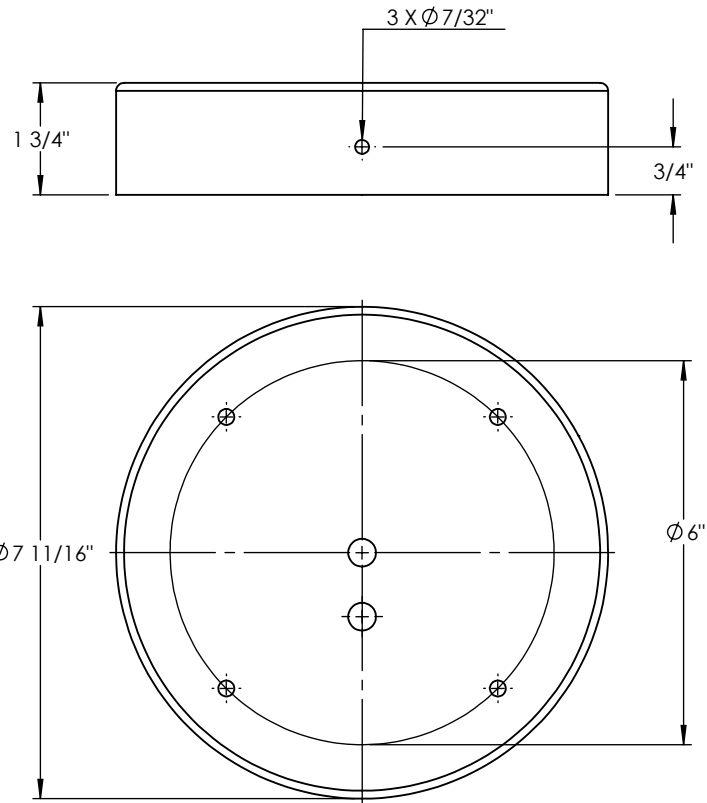

PROPRIETARY AND CONFIDENTIAL
 THE INFORMATION CONTAINED IN THIS DRAWING IS THE SOLE PROPERTY OF <INSERT COMPANY NAME HERE>. ANY REPRODUCTION IN PART OR AS A WHOLE WITHOUT THE WRITTEN PERMISSION OF <INSERT COMPANY NAME HERE> IS PROHIBITED.

		UNLESS OTHERWISE SPECIFIED:		NAME	DATE	SPUN ALUMINUM 0.125"	
		DIMENSIONS ARE IN INCHES TOLERANCES: FRACTIONAL ± ANGULAR: MACH ± BEND ± TWO PLACE DECIMAL ± THREE PLACE DECIMAL ±	DRAWN			TITLE:	
		INTERPRET GEOMETRIC TOLERANCING PER:	CHECKED			WLBWL-20-50W-MN-WF-DIM-35K	
		MATERIAL	ENG APPR.			SIZE	DWG. NO.
		FINISH	MFG APPR.			A	REV
NEXT ASSY	USED ON		Q.A.			SCALE: 1:3	WEIGHT:
APPLICATION		DO NOT SCALE DRAWING	COMMENTS:			SHEET 11 OF 11	