

ITEM NO.	PART NUMBER	DESCRIPTION	QTY.	CUT
1	EVOL11-W-22-215LED-MBK-WDA-35K-0.250" THICK PLATE	1/4" INCH ALUMINUM PLATE	1	
2	EVOL11-W-22-215LED-MBK-WDA-35K-FRAME SPACER	ALUMINUM 0.0635"	1	
3	EVOL11-W-22-215LED-MBK-WDA-35K-LED SPACER	ALUMINUM 0.0635"	1	
4	EVOL11-W-22-215LED-MBK-WDA-35K-BACKPLATE	ALUMINUM 0.0635"	1	
5	EVOL11-W-22-215LED-MBK-WDA-35K-FIREPLATE	ALUMINUM 0.0635"	1	
6	EVOL11-W-22-215LED-MBK-WDA-35K-INSIDE FLANGE	25 GAUGE	4	
7	EVOL11-W-22-215LED-MBK-WDA-35K-ALUMINUM BAR	3/8" SQUARE ALUMINUM BAR	1	
8	EVOLX-W-22-FORMED LENS	ACRYLIC LENS	1	
9	ESPEN VEL29070MVH-1	DRIVER	1	
10	AItailed_PN1004RevD	LED	4	

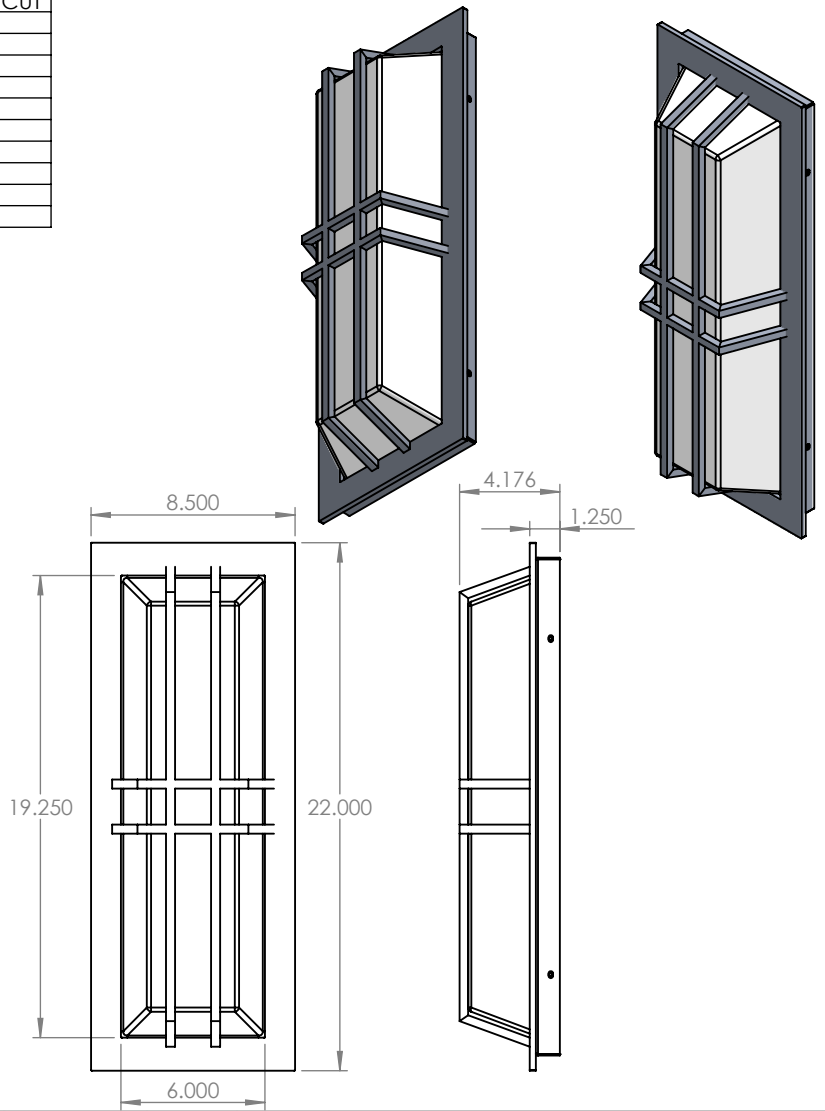
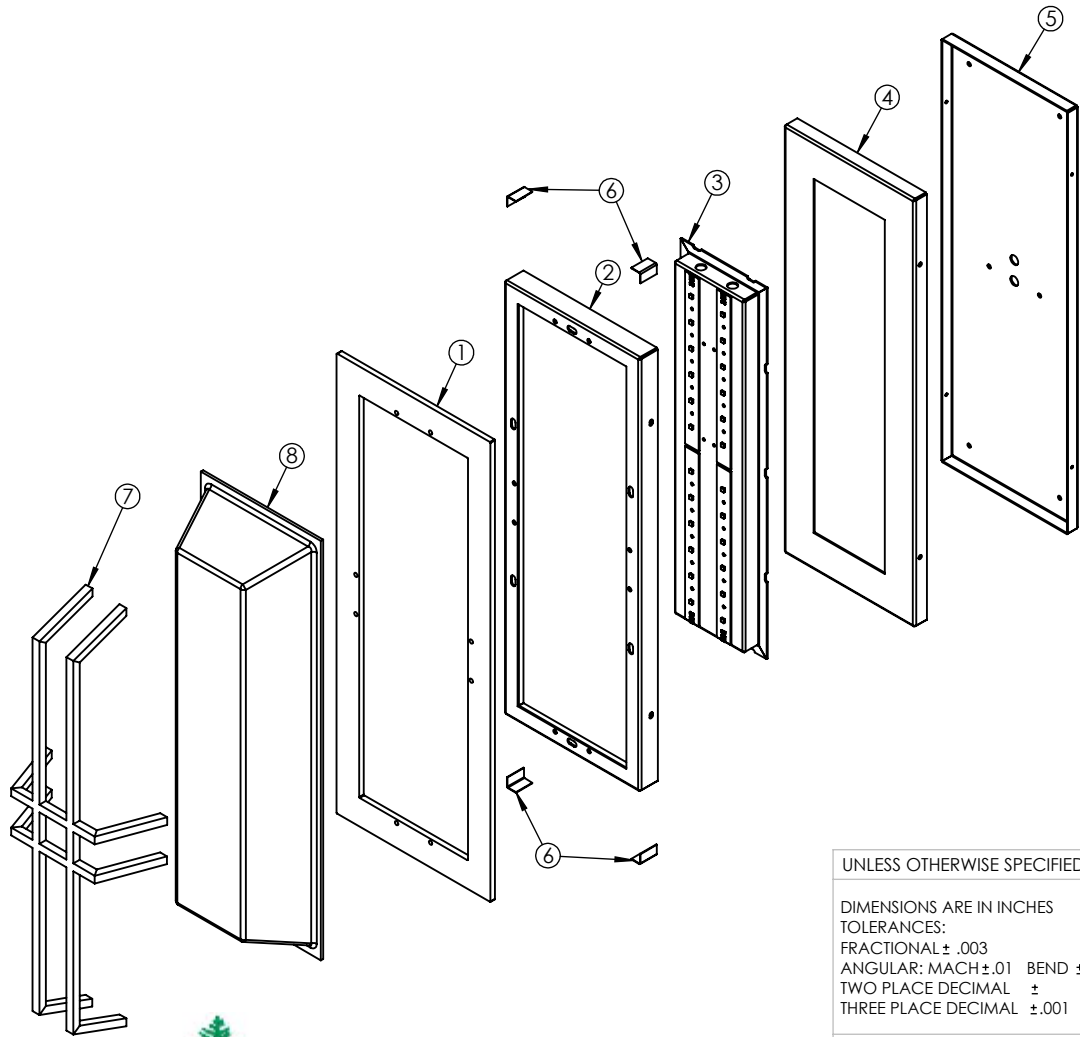

ALL BEND RADIUS .030"

APPLICATION

DO NOT SCALE DRAWING

UNLESS OTHERWISE SPECIFIED:

DIMENSIONS ARE IN INCHES
 TOLERANCES:
 FRACTIONAL ± .003
 ANGULAR: MACH ± .01 BEND ±
 TWO PLACE DECIMAL ±
 THREE PLACE DECIMAL ±.001

INTERPRET GEOMETRIC
 TOLERANCING PER:

MATERIAL

FINISH

NAME	DATE

DRAWN
 CHECKED
 ENG APPR.
 MFG APPR.

Q.A.
 COMMENTS:

TITLE:

EVOL11-W-22-215LED-MBK-WDA-35K

SIZE	DWG. NO.	REV
A	TICKET 26881	

SCALE: 1:8 WEIGHT: SHEET 1 OF 10

5

4

3

2

1

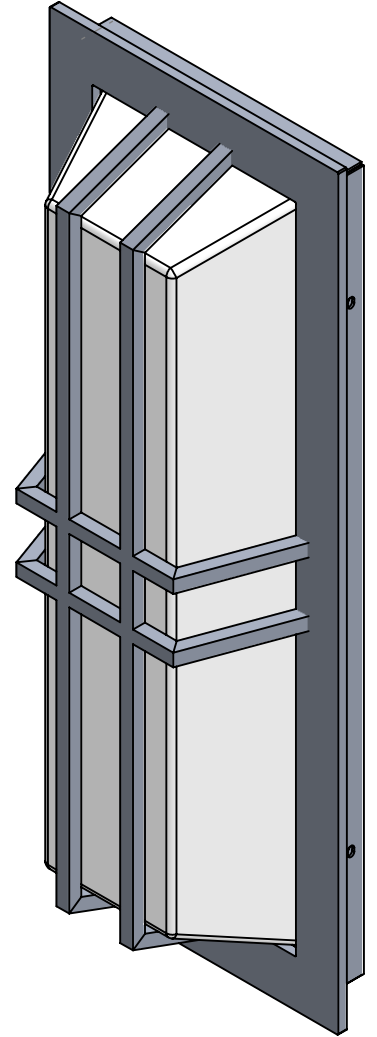
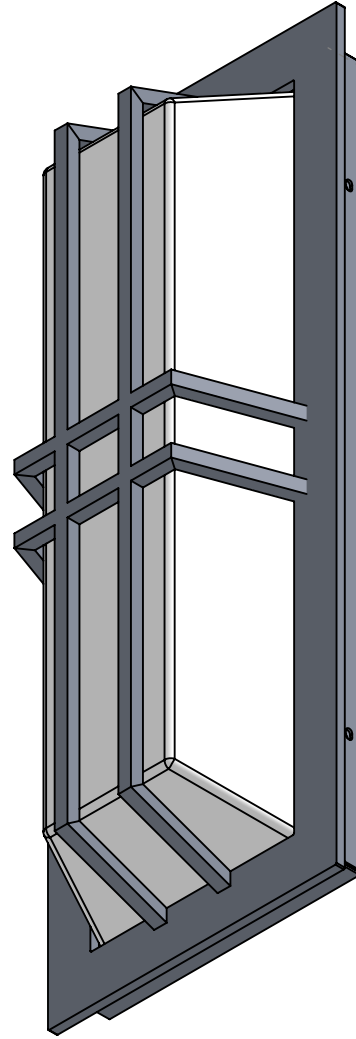
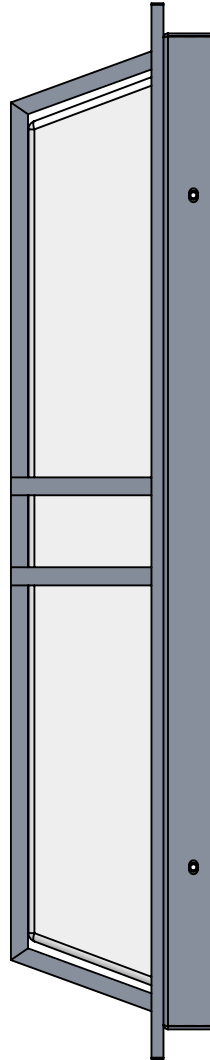
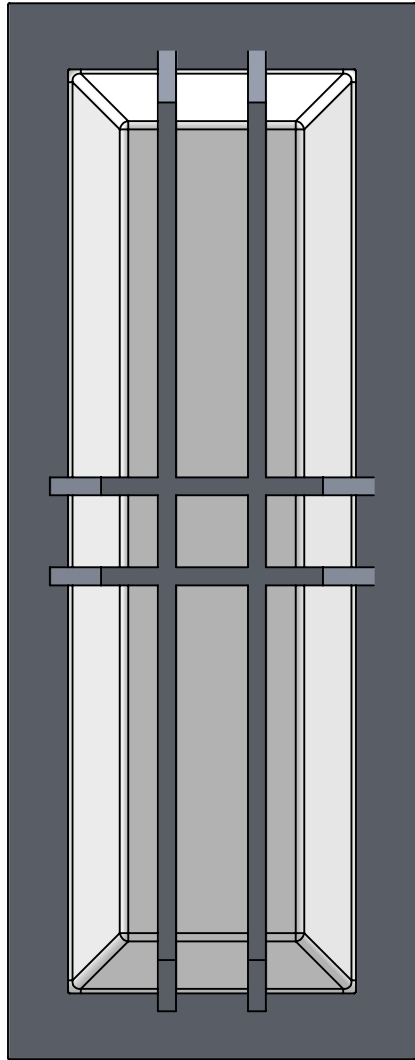
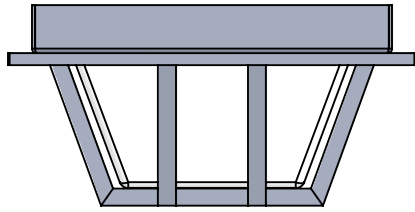

**BAR ACCENT TAPPED AND BOLTED TO FRAME WITH ACCENT
PLATE IN BETWEEN**

**FRAME AND PLATE WELDED FOR ADDED
STRENGTH**

**TABS SPOT WELDED TO FRAME
ON ALL 4 CORNERS**

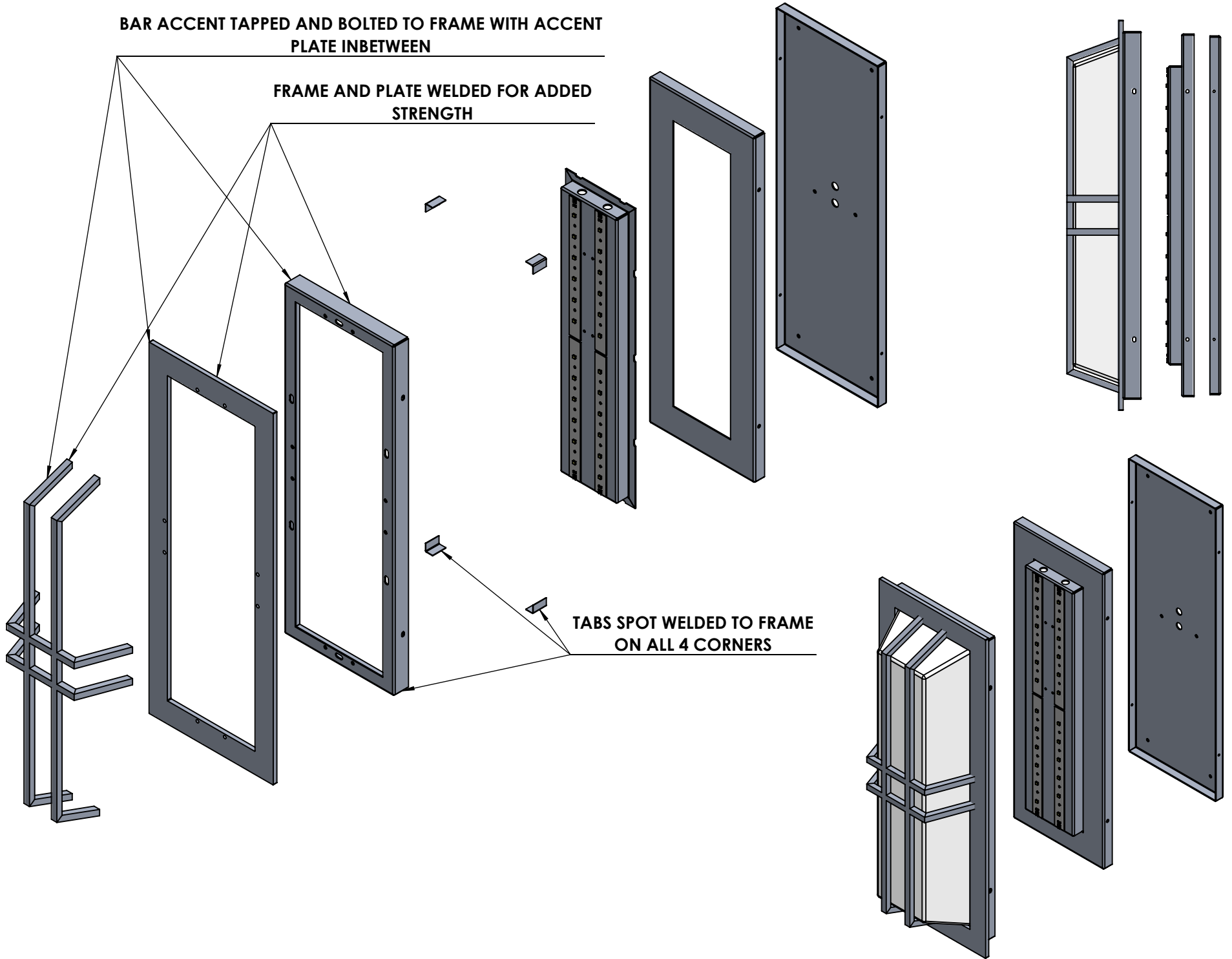

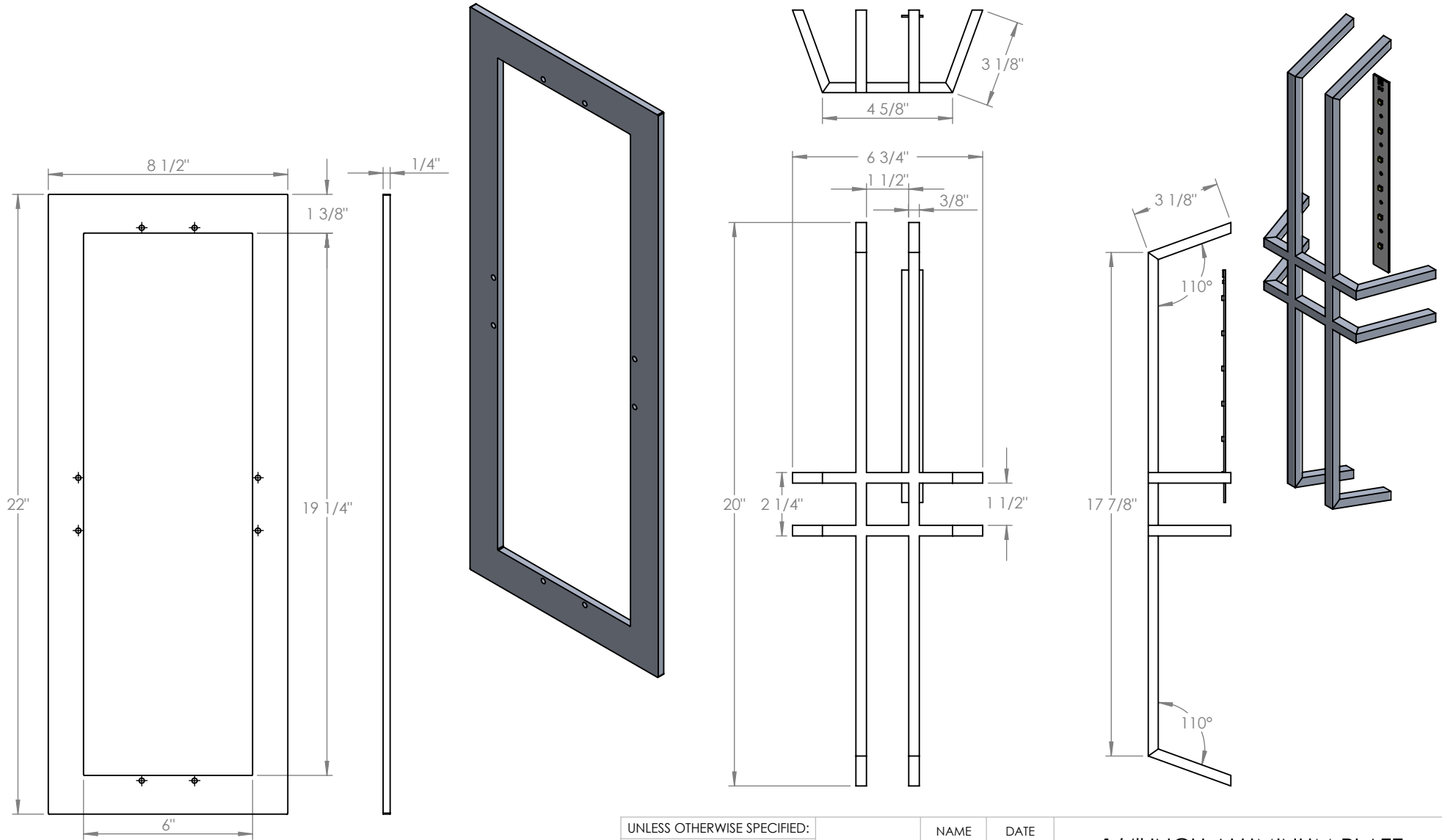

UNLESS OTHERWISE SPECIFIED:		NAME	DATE	1/4" INCH ALUMINUM PLATE	
DIMENSIONS ARE IN INCHES TOLERANCES: FRACTIONAL ± ANGULAR: MACH ± BEND ± TWO PLACE DECIMAL ± THREE PLACE DECIMAL ±		DRAWN			
INTERPRET GEOMETRIC TOLERANCING PER:		CHECKED		EVOL11-W-22-215LED-MBK-WDA-35K	
		ENG APPR.		SIZE	DWG. NO.
MATERIAL		MFG APPR.		REV	
FINISH		Q.A.		SCALE: 1:5	
APPLICATION		COMMENTS:		WEIGHT:	
DO NOT SCALE DRAWING				SHEET 4 OF 10	

PROPRIETARY AND CONFIDENTIAL
THE INFORMATION CONTAINED IN THIS DRAWING IS THE SOLE PROPERTY OF <INSERT COMPANY NAME HERE>. ANY REPRODUCTION IN PART OR AS A WHOLE WITHOUT THE WRITTEN PERMISSION OF <INSERT COMPANY NAME HERE> IS PROHIBITED.

5

4

3

2

1

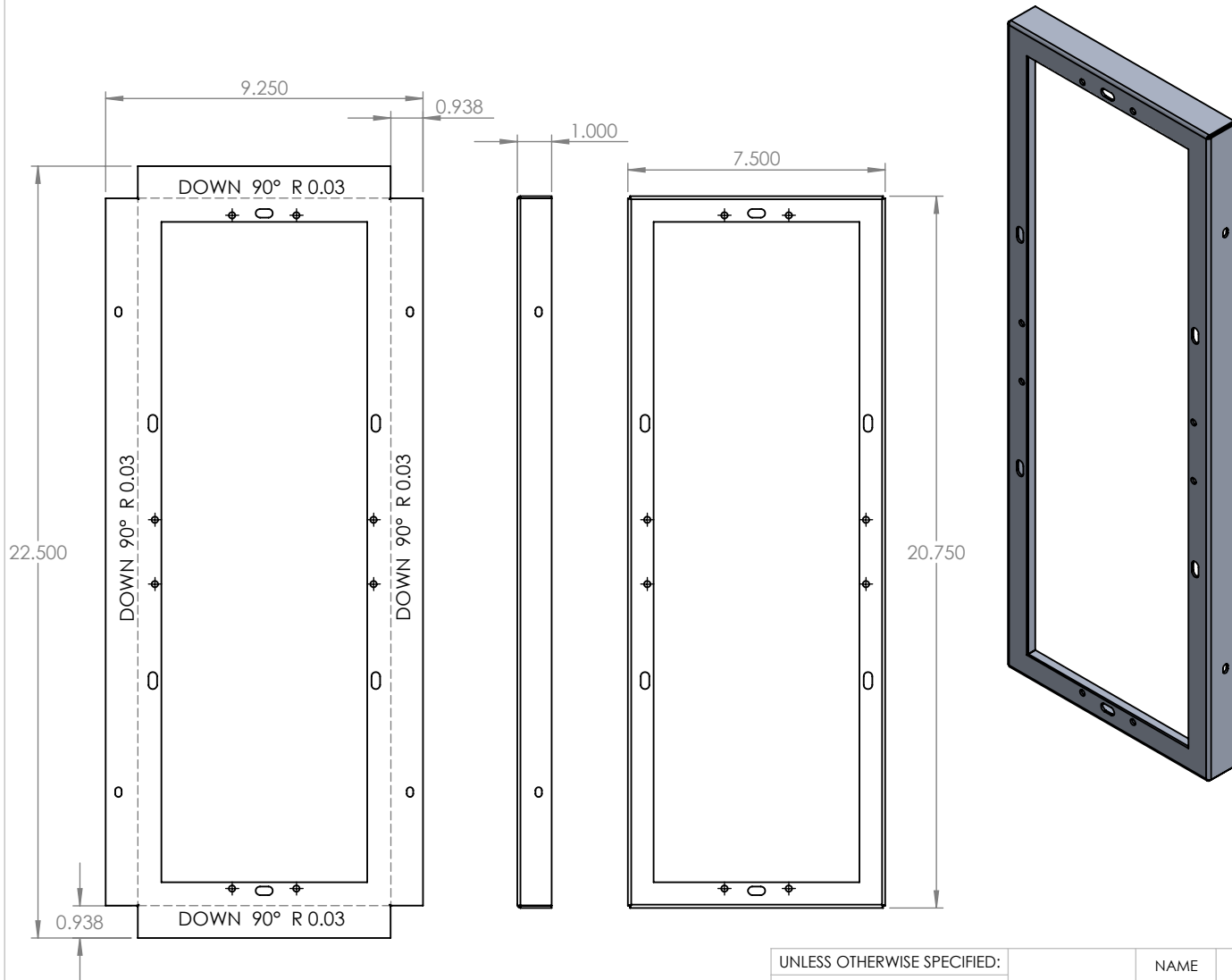

PROPRIETARY AND CONFIDENTIAL
 THE INFORMATION CONTAINED IN THIS DRAWING IS THE SOLE PROPERTY OF <INSERT COMPANY NAME HERE>. ANY REPRODUCTION IN PART OR AS A WHOLE WITHOUT THE WRITTEN PERMISSION OF <INSERT COMPANY NAME HERE> IS PROHIBITED.

		INTERPRET GEOMETRIC TOLERANCING PER:
		MATERIAL
NEXT ASSY	USED ON	FINISH
APPLICATION		DO NOT SCALE DRAWING

UNLESS OTHERWISE SPECIFIED:	NAME	DATE
DIMENSIONS ARE IN INCHES		
TOLERANCES:	DRAWN	
FRACTIONAL ±	CHECKED	
ANGULAR: MACH ± BEND ±	ENG APPR.	
TWO PLACE DECIMAL ±	MFG APPR.	
THREE PLACE DECIMAL ±	Q.A.	
	COMMENTS:	

ALUMINUM 0.0635"		
TITLE:		
EVOL11-W-22-215LED-MBK-WDA-35K		
SIZE	DWG. NO.	REV
A		
SCALE: 1:5	WEIGHT:	SHEET 5 OF 10

5

4

3

2

1

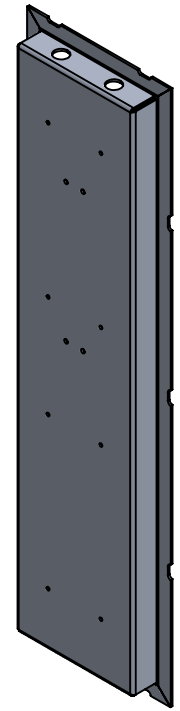
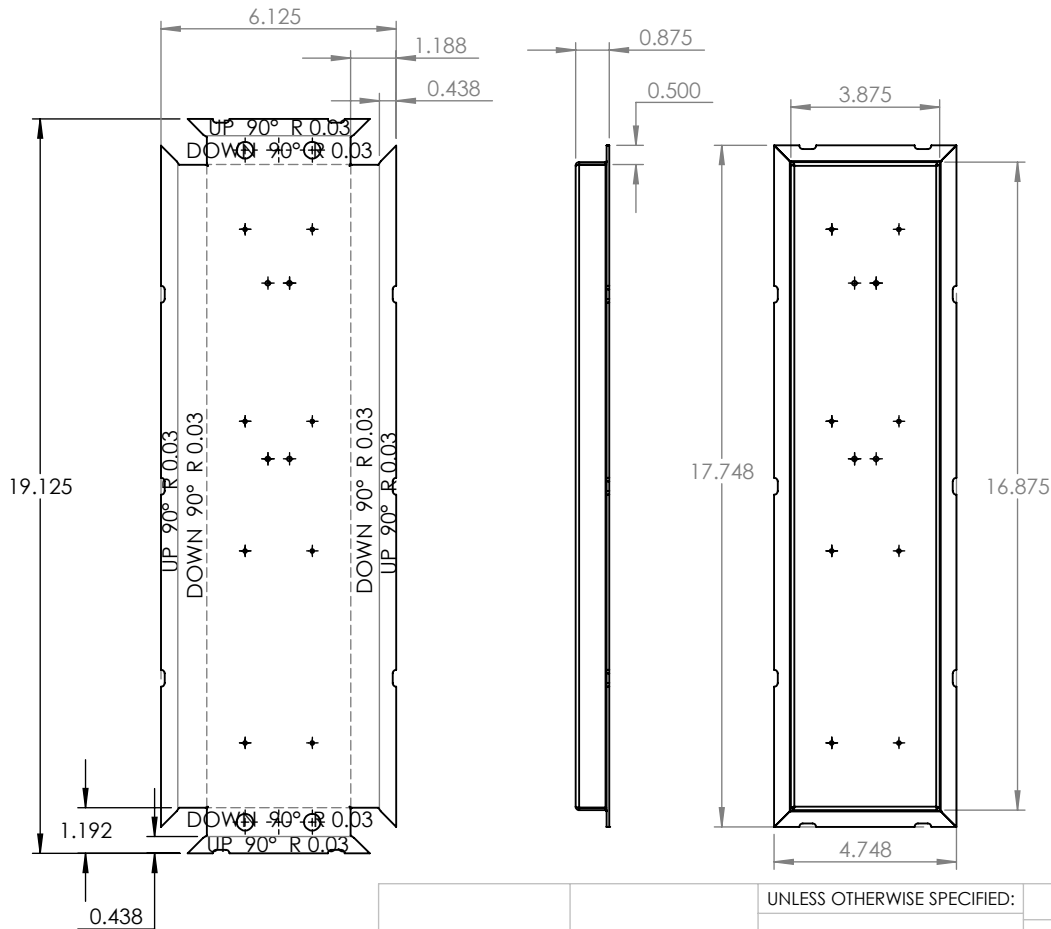

PROPRIETARY AND CONFIDENTIAL
 THE INFORMATION CONTAINED IN THIS DRAWING IS THE SOLE PROPERTY OF <INSERT COMPANY NAME HERE>. ANY REPRODUCTION IN PART OR AS A WHOLE WITHOUT THE WRITTEN PERMISSION OF <INSERT COMPANY NAME HERE> IS PROHIBITED.

		UNLESS OTHERWISE SPECIFIED:	NAME	DATE
		DIMENSIONS ARE IN INCHES	DRAWN	
		TOLERANCES:	CHECKED	
		FRACTIONAL ±	ENG APPR.	
		ANGULAR: MACH ± BEND ±	MFG APPR.	
		TWO PLACE DECIMAL ±	Q.A.	
		THREE PLACE DECIMAL ±	COMMENTS:	
		INTERPRET GEOMETRIC TOLERANCING PER:		
		MATERIAL		
NEXT ASSY	USED ON	FINISH		
APPLICATION		DO NOT SCALE DRAWING		

ALUMINUM 0.0635"		
TITLE:		
EVOL11-W-22-215LED-MBK-WDA-35K		
SIZE	DWG. NO.	REV
A		
SCALE: 1:5	WEIGHT:	SHEET 6 OF 10

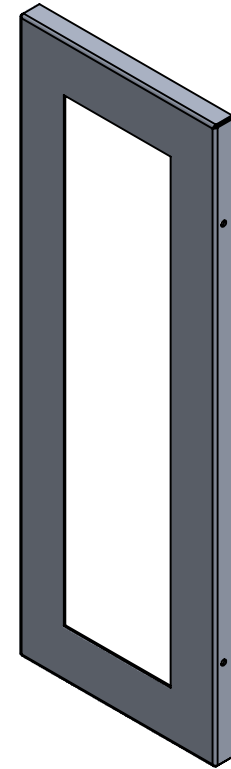
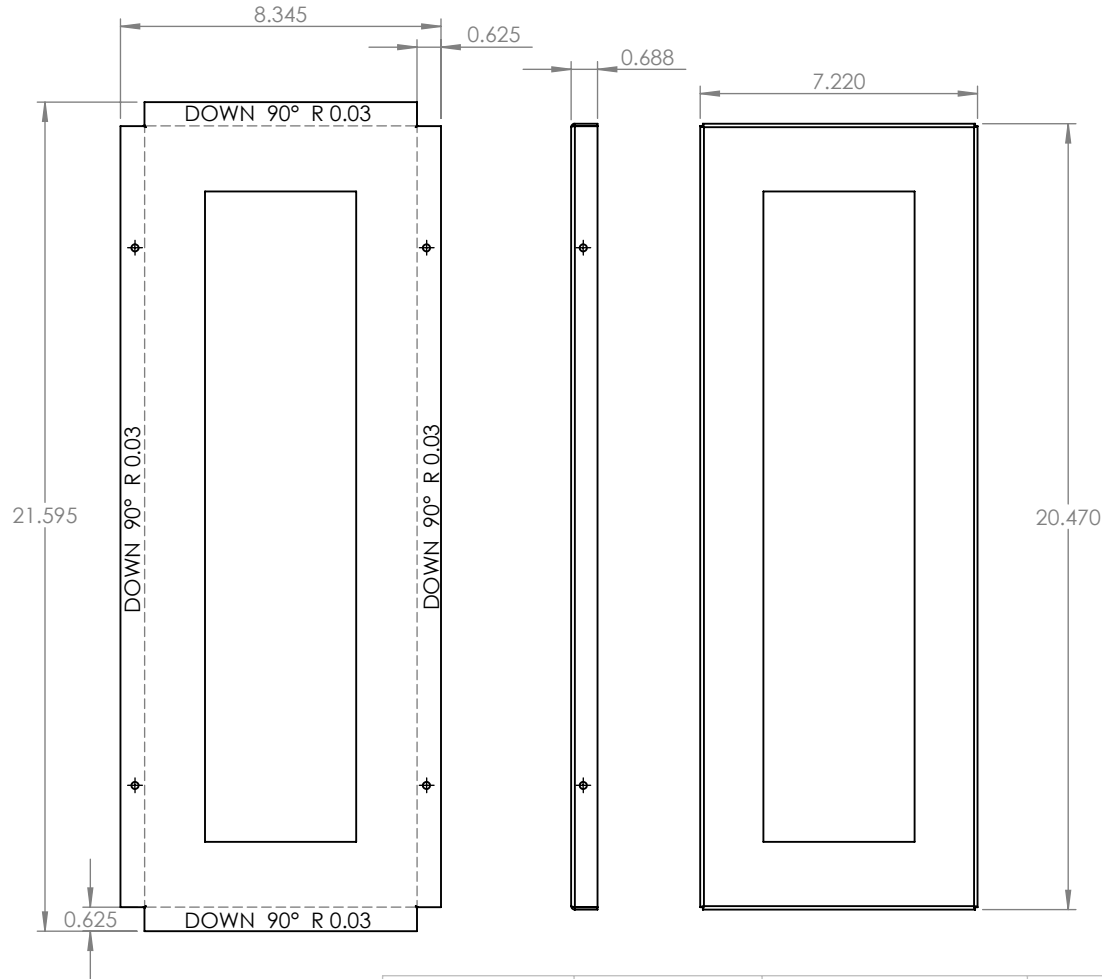

PROPRIETARY AND CONFIDENTIAL
 THE INFORMATION CONTAINED IN THIS DRAWING IS THE SOLE PROPERTY OF <INSERT COMPANY NAME HERE>. ANY REPRODUCTION IN PART OR AS A WHOLE WITHOUT THE WRITTEN PERMISSION OF <INSERT COMPANY NAME HERE> IS PROHIBITED.

		UNLESS OTHERWISE SPECIFIED:	NAME	DATE	ALUMINUM 0.0635"	
		DIMENSIONS ARE IN INCHES	DRAWN		TITLE:	
		TOLERANCES:	CHECKED		EVOL11-W-22-215LED-MBK-WDA-35K	
		FRACTIONAL ±	ENG APPR.		SIZE DWG. NO. REV	
		ANGULAR: MACH ± BEND ±	MFG APPR.		A	
		TWO PLACE DECIMAL ±	Q.A.		SCALE: 1:5 WEIGHT: SHEET 7 OF 10	
		THREE PLACE DECIMAL ±	COMMENTS:			
		INTERPRET GEOMETRIC TOLERANCING PER:				
		MATERIAL				
NEXT ASSY	USED ON	FINISH				
APPLICATION		DO NOT SCALE DRAWING				

5

4

3

2

1

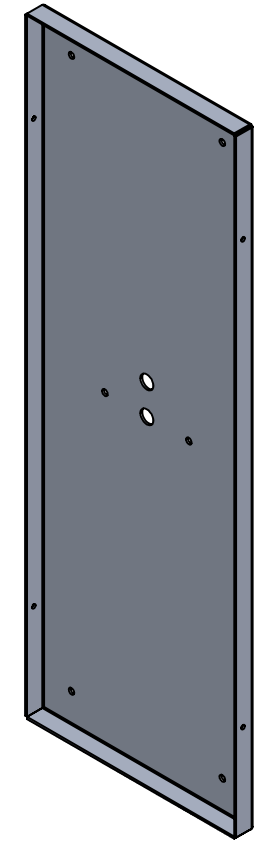
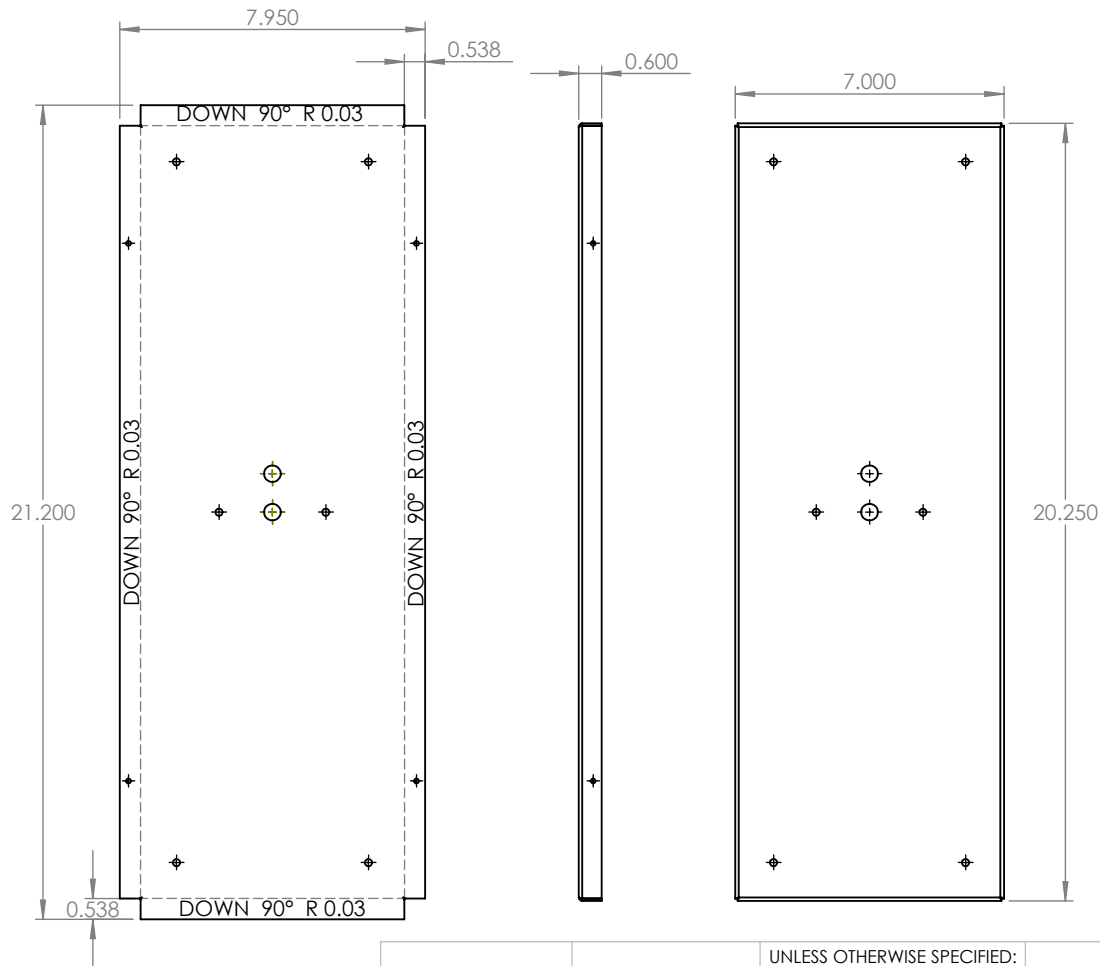

PROPRIETARY AND CONFIDENTIAL
 THE INFORMATION CONTAINED IN THIS DRAWING IS THE SOLE PROPERTY OF <INSERT COMPANY NAME HERE>. ANY REPRODUCTION IN PART OR AS A WHOLE WITHOUT THE WRITTEN PERMISSION OF <INSERT COMPANY NAME HERE> IS PROHIBITED.

		UNLESS OTHERWISE SPECIFIED:	NAME	DATE
		DIMENSIONS ARE IN INCHES	DRAWN	
		TOLERANCES:	CHECKED	
		FRACTIONAL ±	ENG APPR.	
		ANGULAR: MACH ± BEND ±	MFG APPR.	
		TWO PLACE DECIMAL ±	Q.A.	
		THREE PLACE DECIMAL ±	COMMENTS:	
		INTERPRET GEOMETRIC TOLERANCING PER:		
		MATERIAL		
		FINISH		
NEXT ASSY	USED ON			
APPLICATION		DO NOT SCALE DRAWING		

ALUMINUM 0.0635"		
TITLE:		
EVOL11-W-22-215LED-MBK-WDA-35K		
SIZE	DWG. NO.	REV
A		
SCALE: 1:5	WEIGHT:	SHEET 8 OF 10

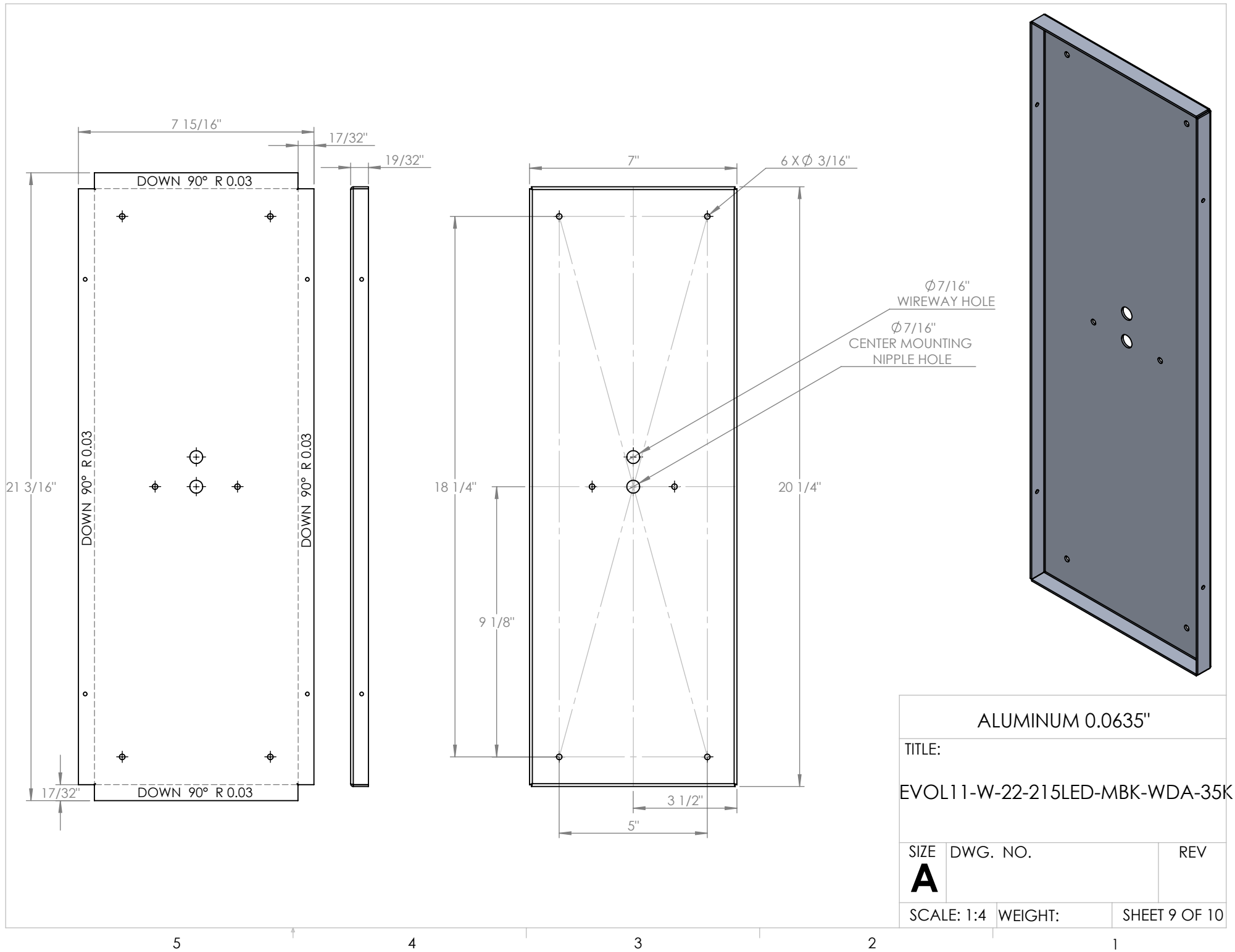

ALUMINUM 0.0635"		
TITLE:		
EVOL11-W-22-215LED-MBK-WDA-35K		
SIZE	DWG. NO.	REV
A		
SCALE: 1:4	WEIGHT:	SHEET 9 OF 10

