

ITEM NO.	PART NUMBER	DESCRIPTION	QTY.	CUT
1	LIN-48VRT-CB-40W-MBK-WF-DIM-480V-WET-35K-FRAME	22 GAUGE	1	
2	LIN-48VRT-CB-40W-MBK-WF-DIM-480V-WET-35K-TOP CAP	22 GAUGE	2	
3	LIN-48VRT-CB-40W-MBK-WF-DIM-480V-WET-35K-BACKPLATE	22 GAUGE	1	
4	LIN-48VRT-CB-40W-MBK-WF-DIM-480V-WET-35K-FIREPLATE	22 GAUGE	1	
5	LIN-48VRT-CB-40W-MBK-WF-DIM-480V-WET-35K-ACRYLIC	ACRYLIC	1	
6	LD40W480-57-CO700 DRIVER	DRIVER	1	
7	Alttailed_PN110B_RevC	LED	4	

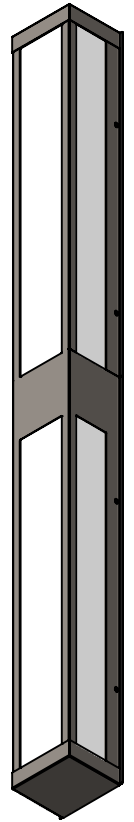
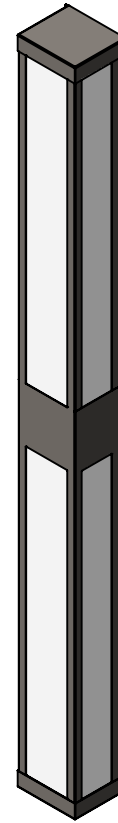
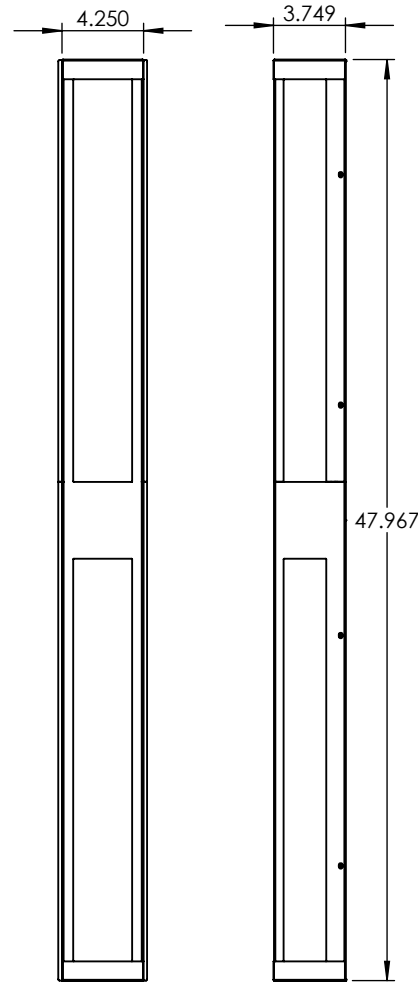
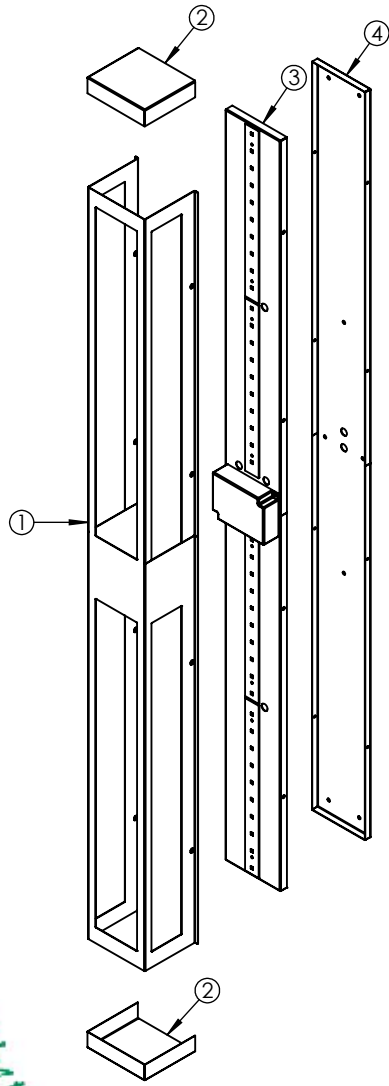

EVERGREEN LIGHTING

ALL BEND RADIUS .030"

APPLICATION

DO NOT SCALE DRAWING

UNLESS OTHERWISE SPECIFIED:

DIMENSIONS ARE IN INCHES
 TOLERANCES:
 FRACTIONAL ± .003
 ANGULAR: MACH ± .01 BEND ±
 TWO PLACE DECIMAL ±
 THREE PLACE DECIMAL ±.001

INTERPRET GEOMETRIC
 TOLERANCING PER:

MATERIAL

FINISH

NAME DATE

DRAWN

CHECKED

ENG APPR.

MFG APPR.

Q.A.

COMMENTS:

TITLE:

LIN-48VRT-CB-40W-MBK-WF-DIM-480V-WET

SIZE DWG. NO.

A TICKET 26901

REV

SCALE: 1:10 WEIGHT:

SHEET 1 OF 7

5

4

3

2

1

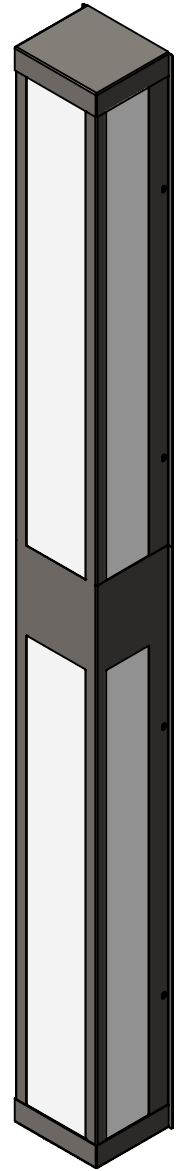
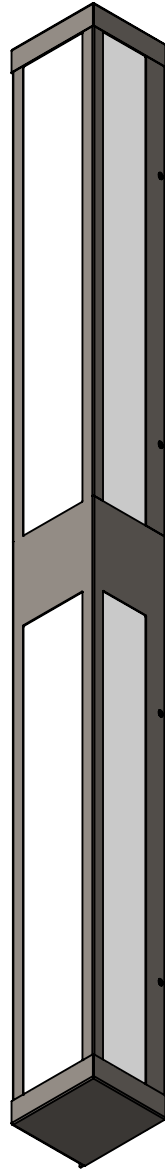
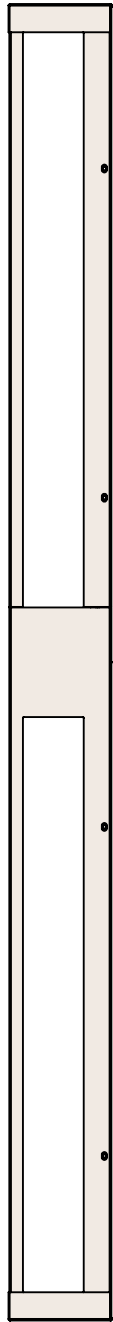
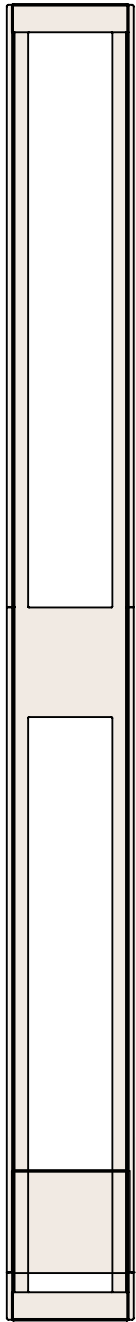

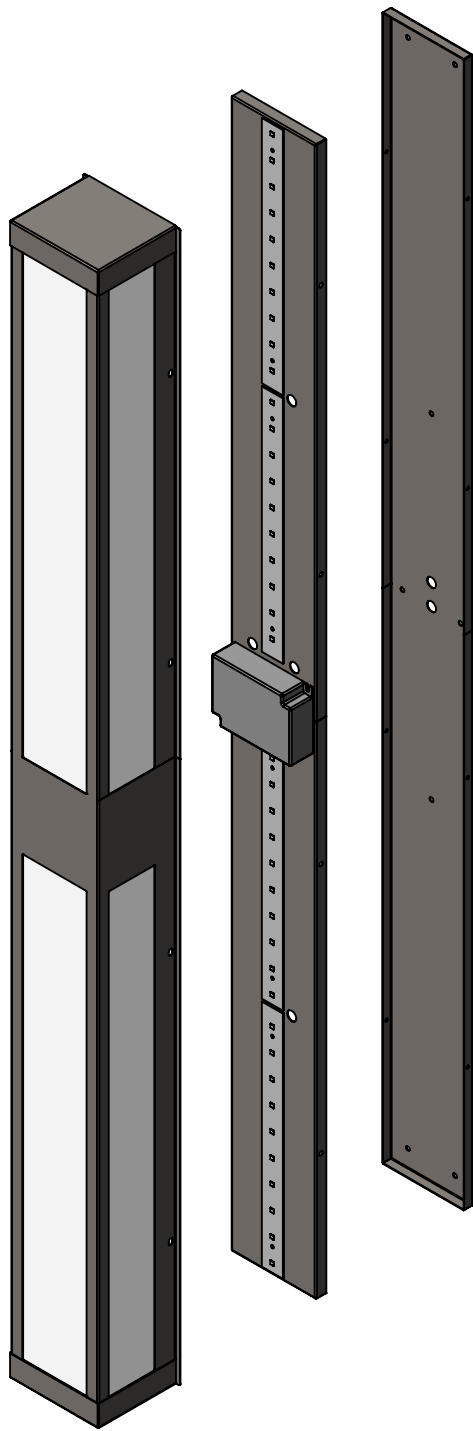

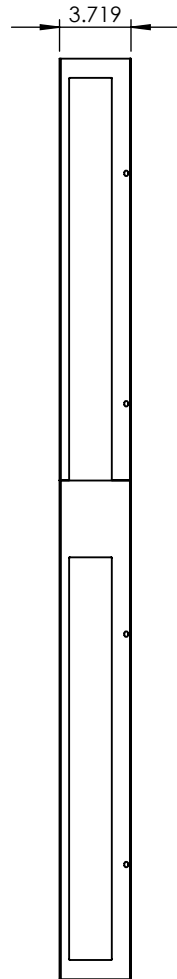
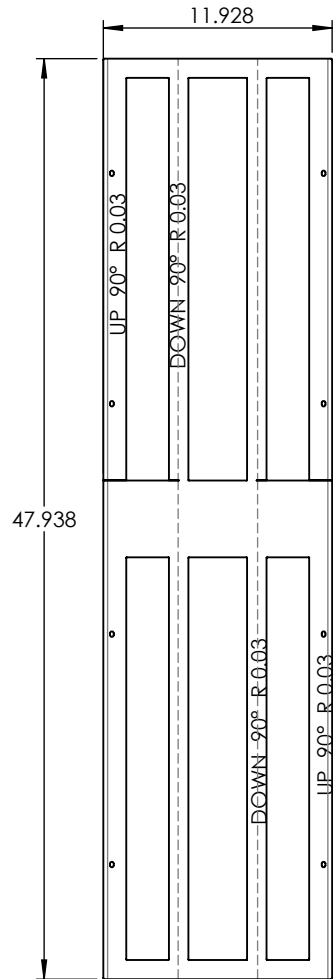
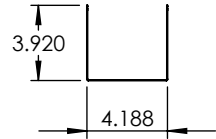
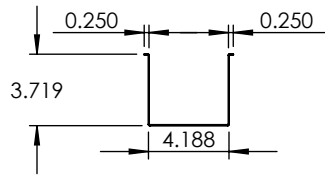

UNLESS OTHERWISE SPECIFIED: DIMENSIONS ARE IN INCHES TOLERANCES: FRACTIONAL ± ANGULAR: MACH ± BEND ± TWO PLACE DECIMAL ± THREE PLACE DECIMAL ±	DRAWN	NAME	DATE	22 GAUGE		
	CHECKED					
	ENG APPR.			LIN-48VRT-CB-40W-MBK-WF-DIM-480V-WET-35		
	MFG APPR.					
INTERPRET GEOMETRIC TOLERANCING PER:	Q.A.			COMMENTS:		
MATERIAL OLI RUBBER BRONZE POWDERCOAT				SIZE	DWG. NO.	REV
FINISH				A		
DO NOT SCALE DRAWING				SCALE: 1:10	WEIGHT:	SHEET 4 OF 7

PROPRIETARY AND CONFIDENTIAL
THE INFORMATION CONTAINED IN THIS DRAWING IS THE SOLE PROPERTY OF <INSERT COMPANY NAME HERE>. ANY REPRODUCTION IN PART OR AS A WHOLE WITHOUT THE WRITTEN PERMISSION OF <INSERT COMPANY NAME HERE> IS PROHIBITED.

NEXT ASSY	USED ON
APPLICATION	

5

4

3

2

1

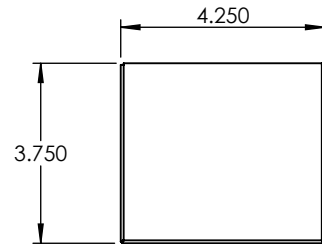
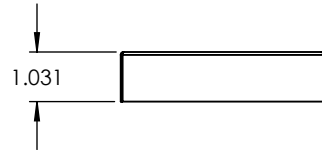
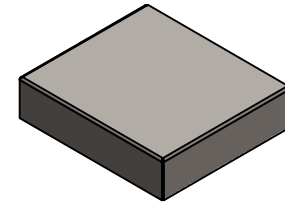
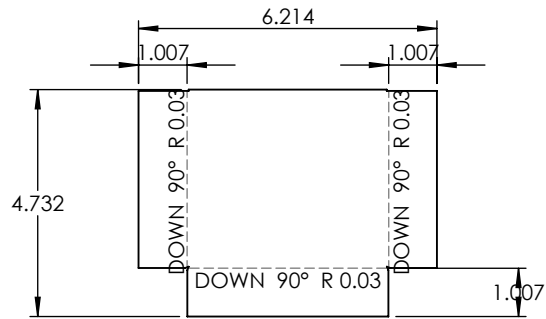

PROPRIETARY AND CONFIDENTIAL
 THE INFORMATION CONTAINED IN THIS DRAWING IS THE SOLE PROPERTY OF <INSERT COMPANY NAME HERE>. ANY REPRODUCTION IN PART OR AS A WHOLE WITHOUT THE WRITTEN PERMISSION OF <INSERT COMPANY NAME HERE> IS PROHIBITED.

		UNLESS OTHERWISE SPECIFIED:		NAME	DATE	22 GAUGE		
		DIMENSIONS ARE IN INCHES TOLERANCES: FRACTIONAL ± ANGULAR: MACH ± BEND ± TWO PLACE DECIMAL ± THREE PLACE DECIMAL ±	DRAWN					TITLE:
		INTERPRET GEOMETRIC TOLERANCING PER:	CHECKED			LIN-48VRT-CB-40W-MBK-WF-DIM-480V-WET-35		
		MATERIAL	ENG APPR.					
		FINISH	MFG APPR.			SIZE	DWG. NO.	REV
NEXT ASSY	USED ON		Q.A.			A		
APPLICATION		DO NOT SCALE DRAWING	COMMENTS:				SCALE: 1:4	WEIGHT:

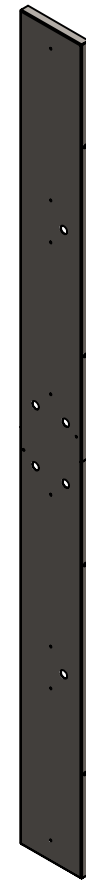
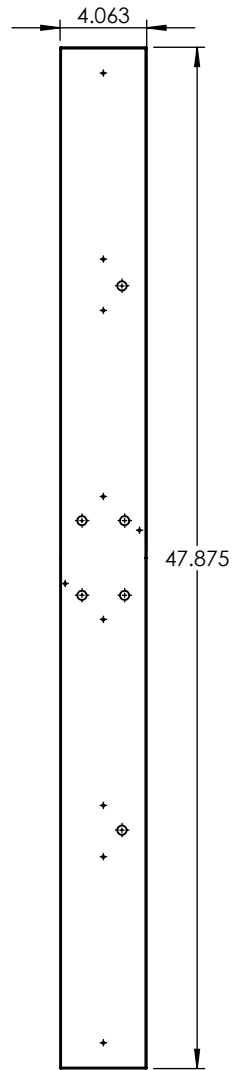
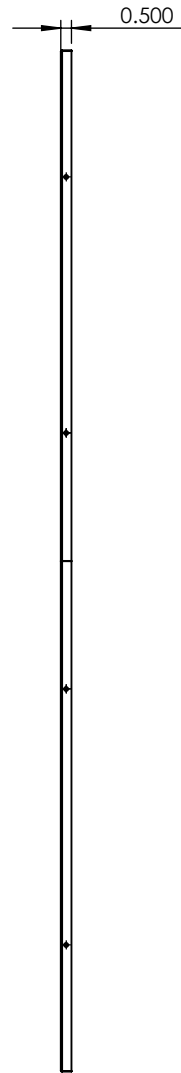
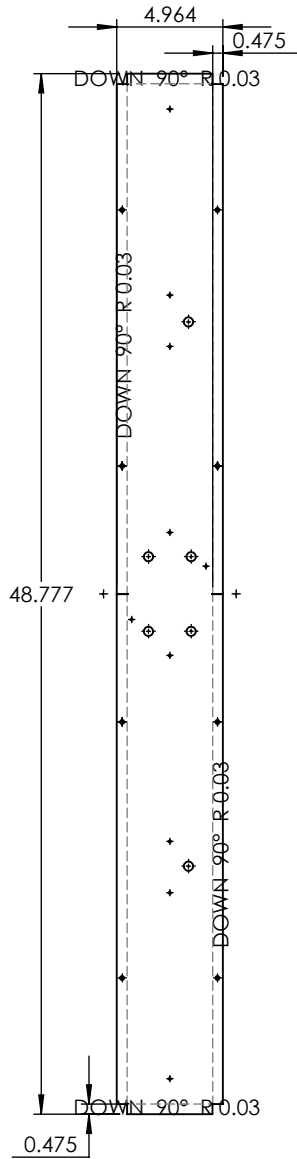

PROPRIETARY AND CONFIDENTIAL
 THE INFORMATION CONTAINED IN THIS DRAWING IS THE SOLE PROPERTY OF <INSERT COMPANY NAME HERE>. ANY REPRODUCTION IN PART OR AS A WHOLE WITHOUT THE WRITTEN PERMISSION OF <INSERT COMPANY NAME HERE> IS PROHIBITED.

		UNLESS OTHERWISE SPECIFIED:	NAME	DATE	22 GAUGE	
		DIMENSIONS ARE IN INCHES	DRAWN			
		TOLERANCES:	CHECKED		LIN-48VRT-CB-40W-MBK-WF-DIM-480V-WET-35	
		FRACTIONAL ±	ENG APPR.			
		ANGULAR: MACH ± BEND ±	MFG APPR.		SCALE: 1:9 WEIGHT: SHEET 6 OF 7	
		TWO PLACE DECIMAL ±	Q.A.			
		THREE PLACE DECIMAL ±	COMMENTS:			
		INTERPRET GEOMETRIC TOLERANCING PER:				
		MATERIAL				
NEXT ASSY	USED ON	FINISH				
APPLICATION		DO NOT SCALE DRAWING				

5

4

3

2

1

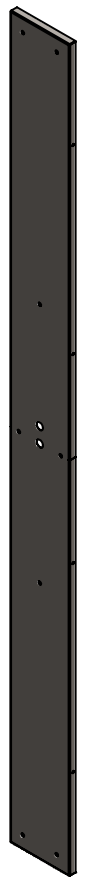
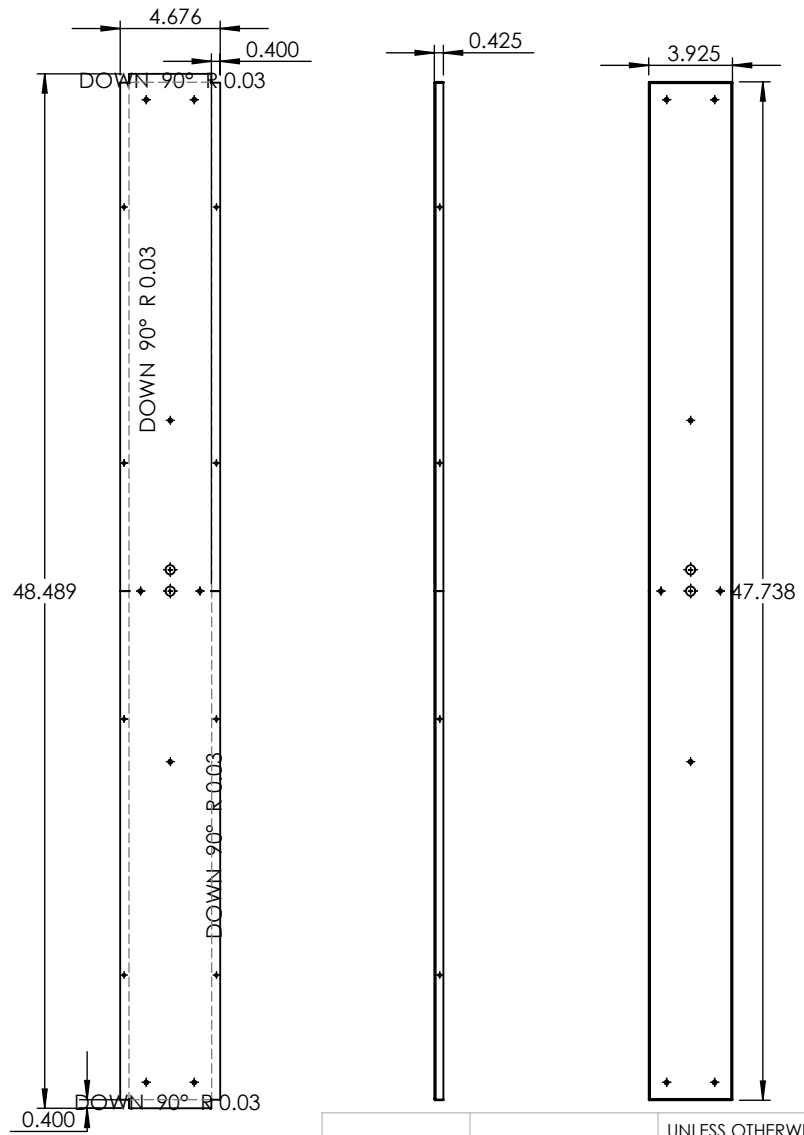

PROPRIETARY AND CONFIDENTIAL
 THE INFORMATION CONTAINED IN THIS DRAWING IS THE SOLE PROPERTY OF <INSERT COMPANY NAME HERE>. ANY REPRODUCTION IN PART OR AS A WHOLE WITHOUT THE WRITTEN PERMISSION OF <INSERT COMPANY NAME HERE> IS PROHIBITED.

		UNLESS OTHERWISE SPECIFIED:	NAME	DATE	22 GAUGE	
		DIMENSIONS ARE IN INCHES	DRAWN			
		TOLERANCES:	CHECKED		LIN-48VRT-CB-40W-MBK-WF-DIM-480V-WET-35	
		FRACTIONAL ±	ENG APPR.			
		ANGULAR: MACH ± BEND ±	MFG APPR.		SCALE: 1:9 WEIGHT: SHEET 7 OF 7	
		TWO PLACE DECIMAL ±	Q.A.			
		THREE PLACE DECIMAL ±	COMMENTS:			
		INTERPRET GEOMETRIC TOLERANCING PER:				
		MATERIAL				
NEXT ASSY		FINISH				
USED ON		DO NOT SCALE DRAWING				
APPLICATION						

5

4

3

2

1