

ITEM NO.	PART NUMBER	DESCRIPTION	QTY.	CUT
1	STP-REC-HDCO12X10-12L-AB-A-30K-FACE PLATE	ALUMINUM 0.0635"	1	
2	STP-REC-HDCO12X10-12L-AB-A-30K-FRAME PLATE	22 GAUGE	1	
3	STP-REC-HDCO12X10-12L-AB-A-30K-RECESSED BOX	22 GAUGE	1	
4	STP-REC-HDCO12X10-12L-AB-A-30K-BOX TAB	22 GAUGE	4	
5	STP-REC-HDCO12X10-12L-AB-A-30K-LED PLATE	22 GAUGE	1	
6	STP-REC-HDCO12X10-12L-AB-A-30K-LED PLATE BRACKET	22 GAUGE	2	
7	STP-REC-HDCO12X10-12L-AB-A-30K-ACRYLIC	ACRYLIC	1	
8	Altai_LED_PN1019_SHIM PLATE	ALUMINUM 0.125" PLATE	1	
9	EspenTECH_120277V_SKU808076	DRIVER	1	
10	Altai_LED_PN1019_RevC	LED	1	

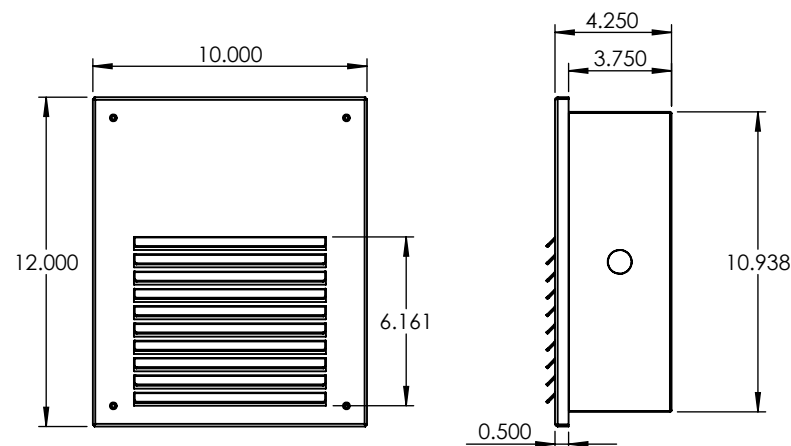

UNLESS OTHERWISE SPECIFIED:		NAME	DATE	TITLE:
DIMENSIONS ARE IN INCHES TOLERANCES: FRACTIONAL ± .003 ANGULAR: MACH ± .01 BEND ± TWO PLACE DECIMAL ± THREE PLACE DECIMAL ±.001		DRAWN		
INTERPRET GEOMETRIC TOLERANCING PER:		CHECKED		
MATERIAL		ENG APPR.		
FINISH		MFG APPR.		
ALL BEND RADIUS .030"		Q.A.		SIZE DWG. NO.
APPLICATION		COMMENTS:		A TICKET 26923
DO NOT SCALE DRAWING				REV
		SCALE: 1:7	WEIGHT:	SHEET 1 OF 6

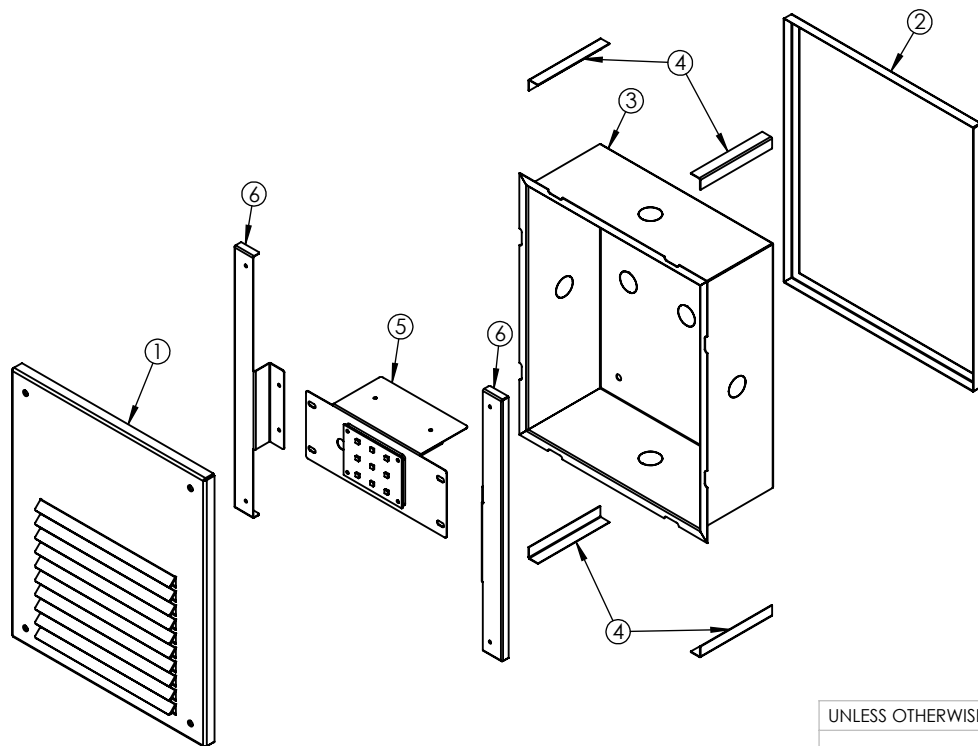
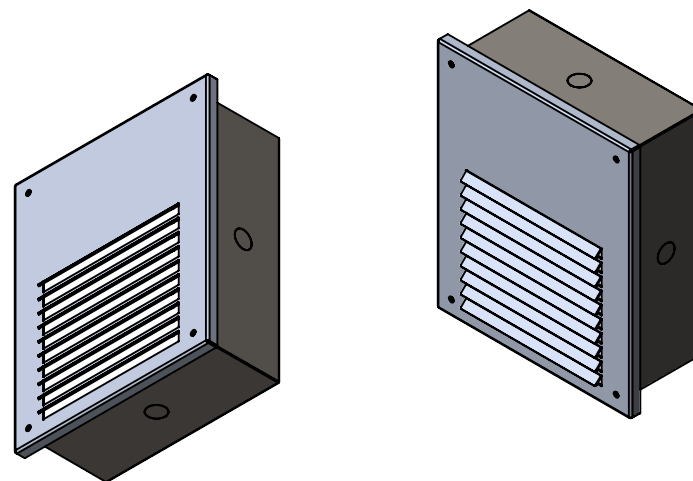

EVERGREEN LIGHTING

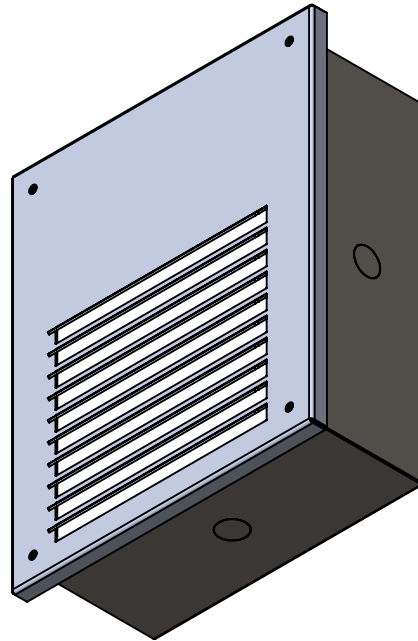
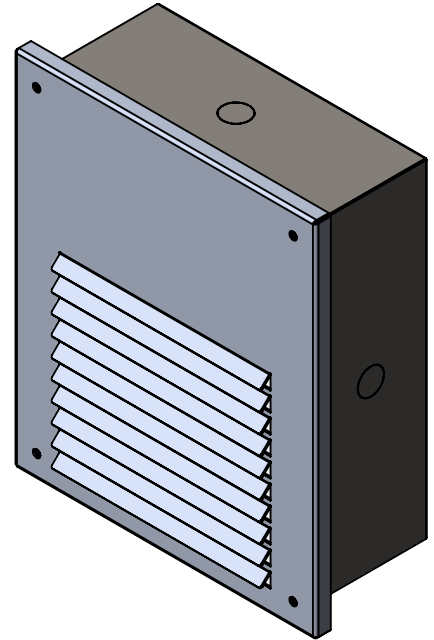
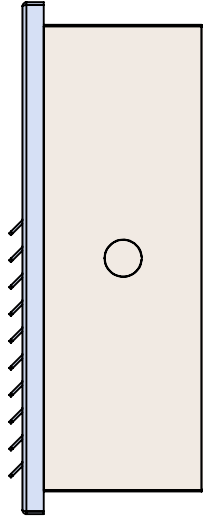
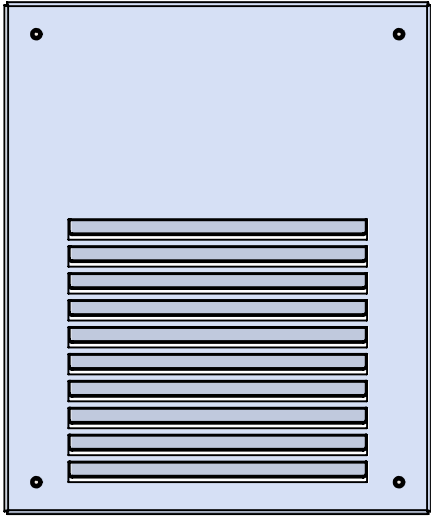

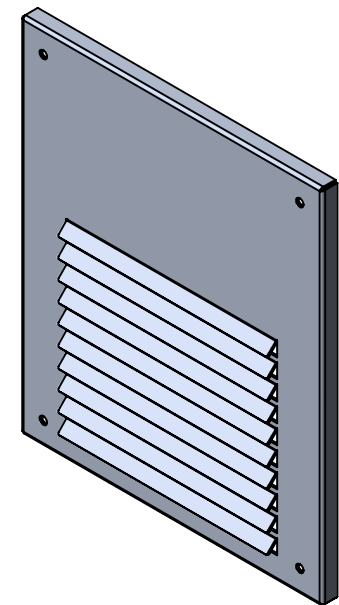
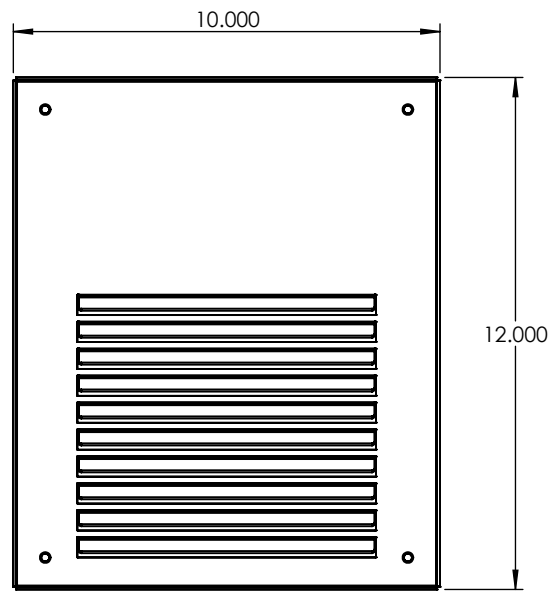
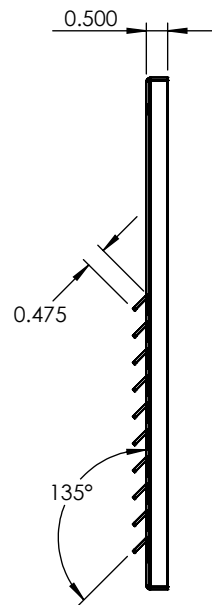
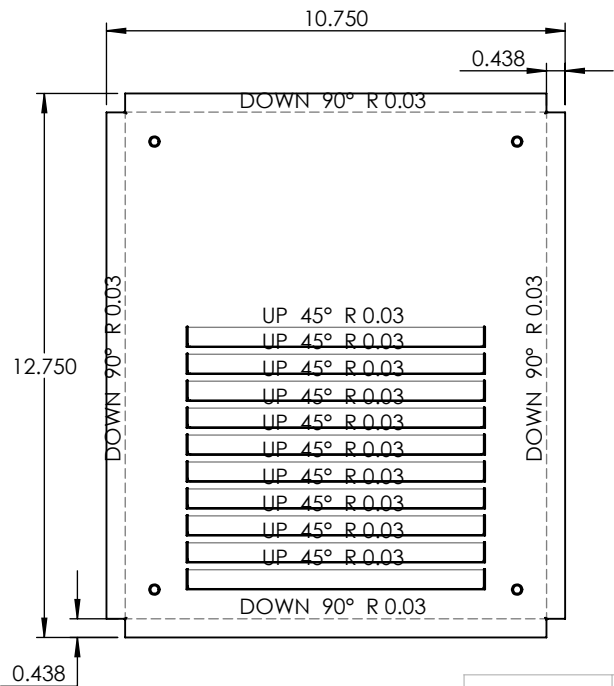

PROPRIETARY AND CONFIDENTIAL
 THE INFORMATION CONTAINED IN THIS DRAWING IS THE SOLE PROPERTY OF <INSERT COMPANY NAME HERE>. ANY REPRODUCTION IN PART OR AS A WHOLE WITHOUT THE WRITTEN PERMISSION OF <INSERT COMPANY NAME HERE> IS PROHIBITED.

		UNLESS OTHERWISE SPECIFIED:		NAME	DATE
		DIMENSIONS ARE IN INCHES	DRAWN		
		TOLERANCES:	CHECKED		
		FRACTIONAL ±	ENG APPR.		
		ANGULAR: MACH ± BEND ±	MFG APPR.		
		TWO PLACE DECIMAL ±	Q.A.		
		THREE PLACE DECIMAL ±	COMMENTS:		
		INTERPRET GEOMETRIC TOLERANCING PER:			
		MATERIAL			
NEXT ASSY	USED ON	FINISH			
	APPLICATION	DO NOT SCALE DRAWING			

ALUMINUM 0.0635"		
TITLE:		
STP-REC-HDCO12X10-12L-AB-A-30K		
SIZE	DWG. NO.	REV
A		
SCALE: 1:4.5		WEIGHT:
		SHEET 3 OF 6

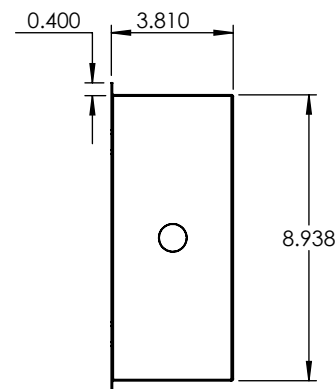
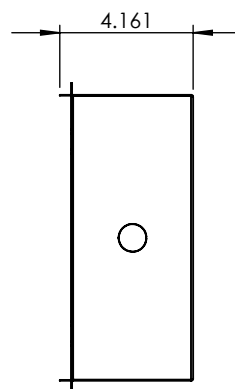
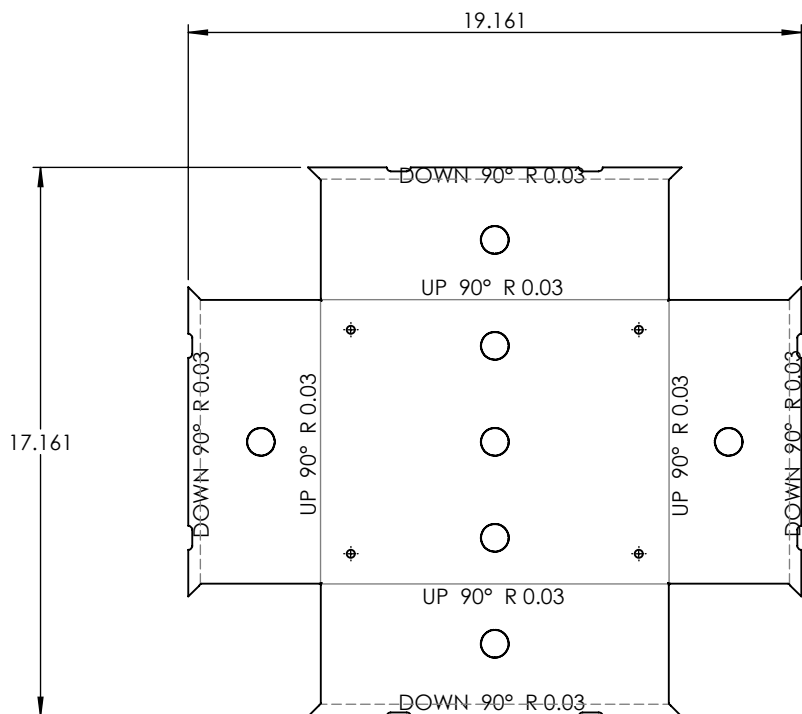
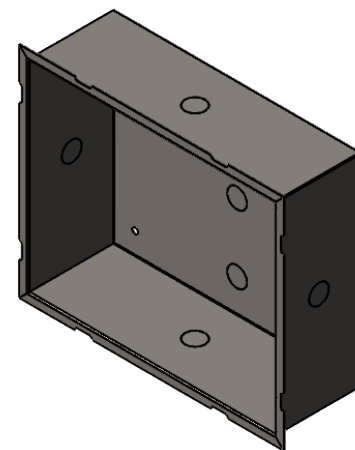
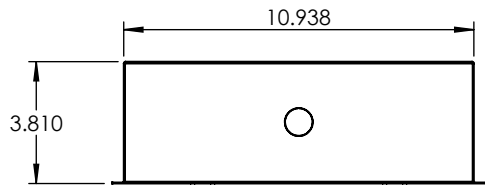

UNLESS OTHERWISE SPECIFIED:		NAME	DATE	22 GAUGE							
DIMENSIONS ARE IN INCHES TOLERANCES: FRACTIONAL ± ANGULAR: MACH ± BEND ± TWO PLACE DECIMAL ± THREE PLACE DECIMAL ±		DRAWN				TITLE:					
INTERPRET GEOMETRIC TOLERANCING PER:		CHECKED		STP-REC-HDCO12X10-12L-AB-A-30K							
		ENG APPR.									
MATERIAL		MFG APPR.		<table border="1" style="width: 100%;"> <tr> <td>SIZE</td> <td>DWG. NO.</td> <td>REV</td> </tr> <tr> <td style="text-align: center; font-size: 2em;">A</td> <td></td> <td></td> </tr> </table>		SIZE	DWG. NO.	REV	A		
		SIZE	DWG. NO.			REV					
A											
FINISH		Q.A.		<table border="1" style="width: 100%;"> <tr> <td>SCALE: 1:6</td> <td>WEIGHT:</td> <td>SHEET 4 OF 6</td> </tr> </table>		SCALE: 1:6	WEIGHT:	SHEET 4 OF 6			
SCALE: 1:6	WEIGHT:	SHEET 4 OF 6									
DO NOT SCALE DRAWING		COMMENTS:									

PROPRIETARY AND CONFIDENTIAL
THE INFORMATION CONTAINED IN THIS DRAWING IS THE SOLE PROPERTY OF <INSERT COMPANY NAME HERE>. ANY REPRODUCTION IN PART OR AS A WHOLE WITHOUT THE WRITTEN PERMISSION OF <INSERT COMPANY NAME HERE> IS PROHIBITED.

NEXT ASSY	USED ON
APPLICATION	

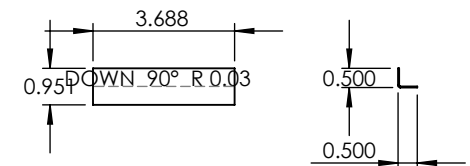
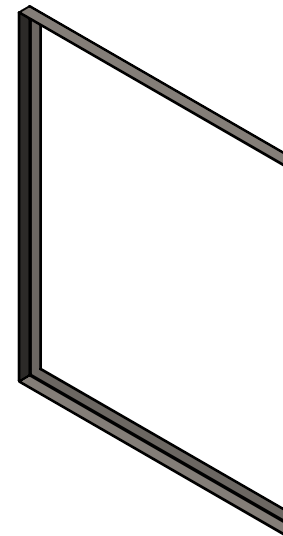
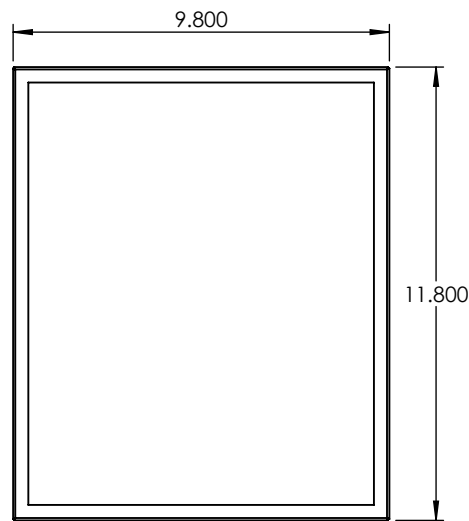
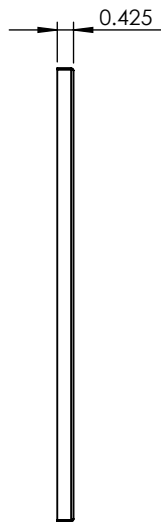
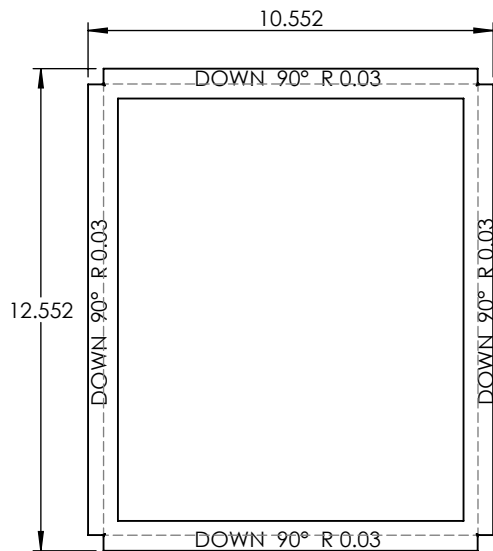

PROPRIETARY AND CONFIDENTIAL
 THE INFORMATION CONTAINED IN THIS DRAWING IS THE SOLE PROPERTY OF <INSERT COMPANY NAME HERE>. ANY REPRODUCTION IN PART OR AS A WHOLE WITHOUT THE WRITTEN PERMISSION OF <INSERT COMPANY NAME HERE> IS PROHIBITED.

		UNLESS OTHERWISE SPECIFIED:	NAME	DATE	22 GAUGE	
		DIMENSIONS ARE IN INCHES TOLERANCES: FRACTIONAL ± ANGULAR: MACH ± BEND ± TWO PLACE DECIMAL ± THREE PLACE DECIMAL ±	DRAWN			
		INTERPRET GEOMETRIC TOLERANCING PER:	CHECKED		STP-REC-HDCO12X10-12L-AB-A-30K	
		MATERIAL	ENG APPR.			
		FINISH	MFG APPR.		SIZE	DWG. NO.
NEXT ASSY	USED ON		Q.A.		A	
APPLICATION		DO NOT SCALE DRAWING	COMMENTS:		SCALE: 1:5	WEIGHT:
						SHEET 5 OF 6

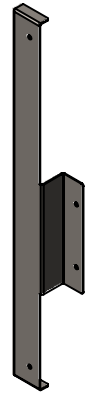
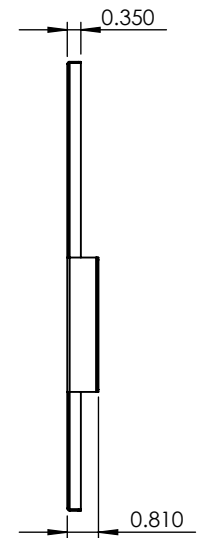
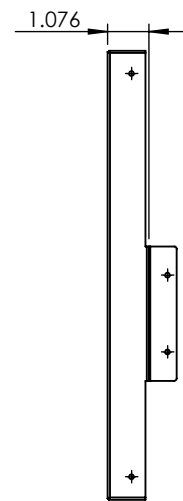
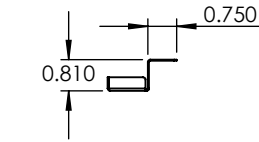
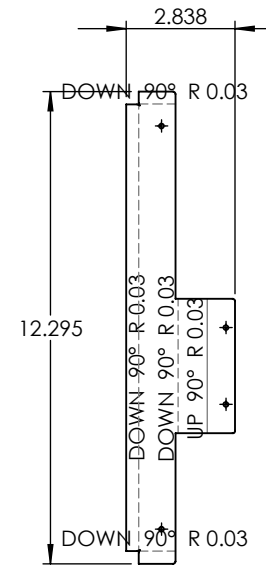
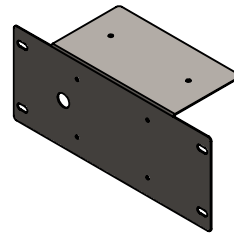
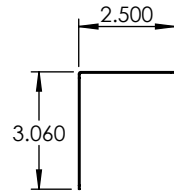
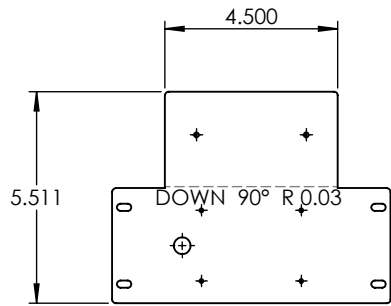

PROPRIETARY AND CONFIDENTIAL
 THE INFORMATION CONTAINED IN THIS DRAWING IS THE SOLE PROPERTY OF <INSERT COMPANY NAME HERE>. ANY REPRODUCTION IN PART OR AS A WHOLE WITHOUT THE WRITTEN PERMISSION OF <INSERT COMPANY NAME HERE> IS PROHIBITED.

		UNLESS OTHERWISE SPECIFIED:		NAME	DATE	22 GAUGE		
		DIMENSIONS ARE IN INCHES TOLERANCES: FRACTIONAL ± ANGULAR: MACH ± BEND ± TWO PLACE DECIMAL ± THREE PLACE DECIMAL ±	DRAWN					TITLE:
		INTERPRET GEOMETRIC TOLERANCING PER:	CHECKED			STP-REC-HDCO12X10-12L-AB-A-30K		
		MATERIAL	ENG APPR.			SIZE	DWG. NO.	REV
NEXT ASSY	USED ON	FINISH	MFG APPR.			A		
APPLICATION		DO NOT SCALE DRAWING	COMMENTS:				SCALE: 1:5	WEIGHT: