

ITEM NO.	PART NUMBER	DESCRIPTION	QTY.	CUT
1	LIN-W-DN-36X5-18LS-BLK-WF-WET-30K-FRAME	22 GAUGE	1	
2	LIN-W-DN-36X5-18LS-BLK-WF-WET-30K-FRAME TAB	22 GAUGE	4	
3	LIN-W-DN-36X5-18LS-BLK-WF-WET-30K-BACKPLATE	22 GAUGE	1	
4	LIN-W-DN-36X5-18LS-BLK-WF-WET-30K-ACRYLIC	ACRYLIC	1	
5	ESPEN VEL29070MVH-1	DRIVER	1	
6	LIN-W-DN-36X5-18LS-BLK-WF-WET-30K-LED BRACKET	22 GAUGE	1	
7	LIN-W-DN-36X5-18LS-BLK-WF-WET-30K-FIREPLATE	22 GAUGE	1	
8	AltLED_PN1010_RevD	LED	4	

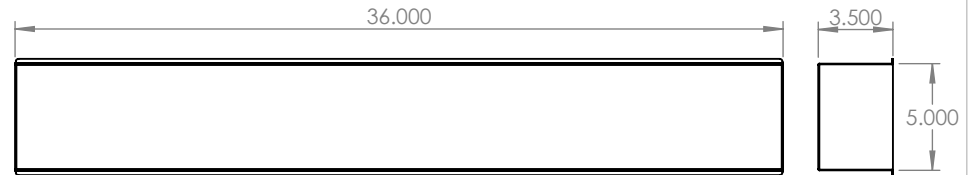
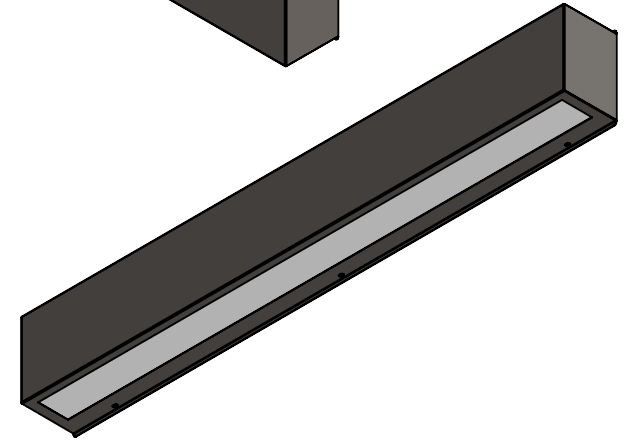
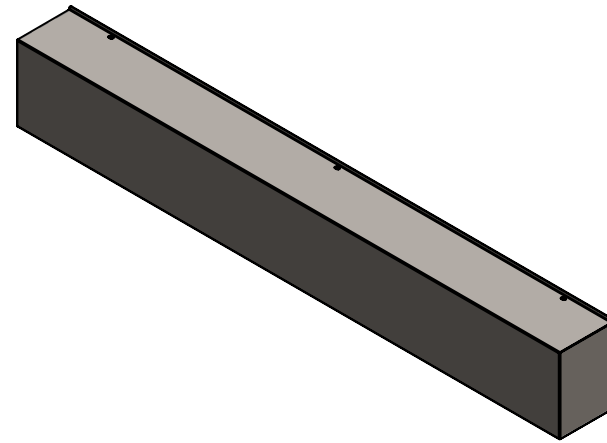
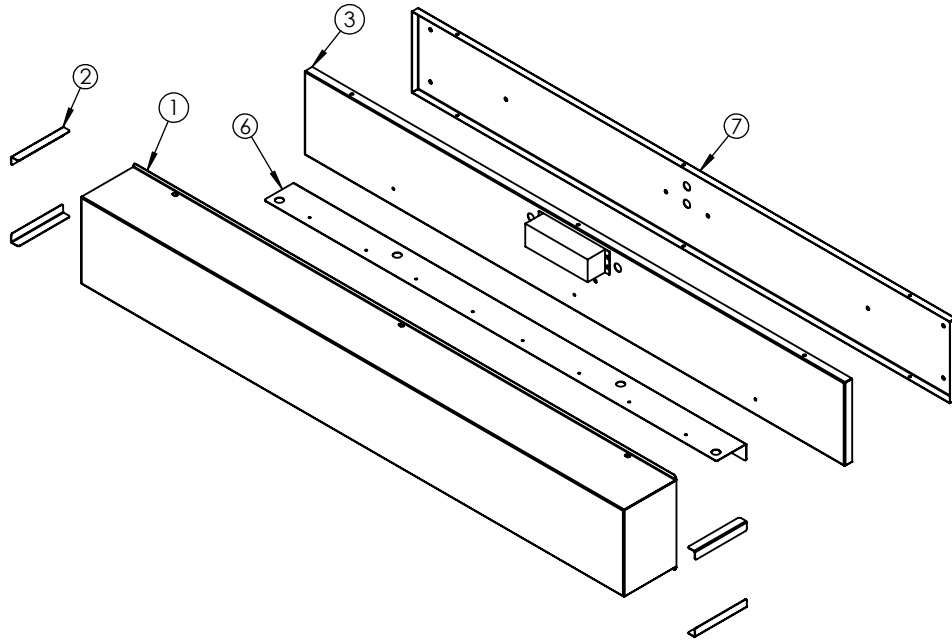

ALL BEND RADIUS .030"

APPLICATION

DO NOT SCALE DRAWING

UNLESS OTHERWISE SPECIFIED:

DIMENSIONS ARE IN INCHES
 TOLERANCES:
 FRACTIONAL ± .003
 ANGULAR: MACH ± .01 BEND ±
 TWO PLACE DECIMAL ±
 THREE PLACE DECIMAL ±.001

INTERPRET GEOMETRIC
 TOLERANCING PER:

MATERIAL

FINISH

NAME

DATE

DRAWN

CHECKED

ENG APPR.

MFG APPR.

Q.A.

COMMENTS:

TITLE:

LIN-W-DN-36X5-18LS-BLK-WF-WET-30K

SIZE DWG. NO.

A TICKET 26948

REV

SCALE: 1:9

WEIGHT:

SHEET 1 OF 6

5

4

3

2

1

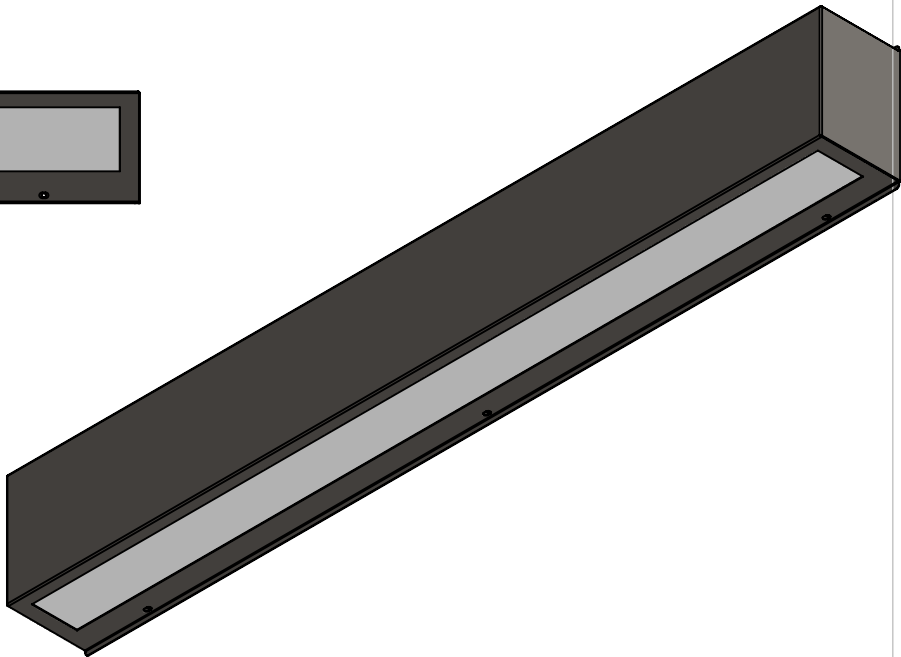
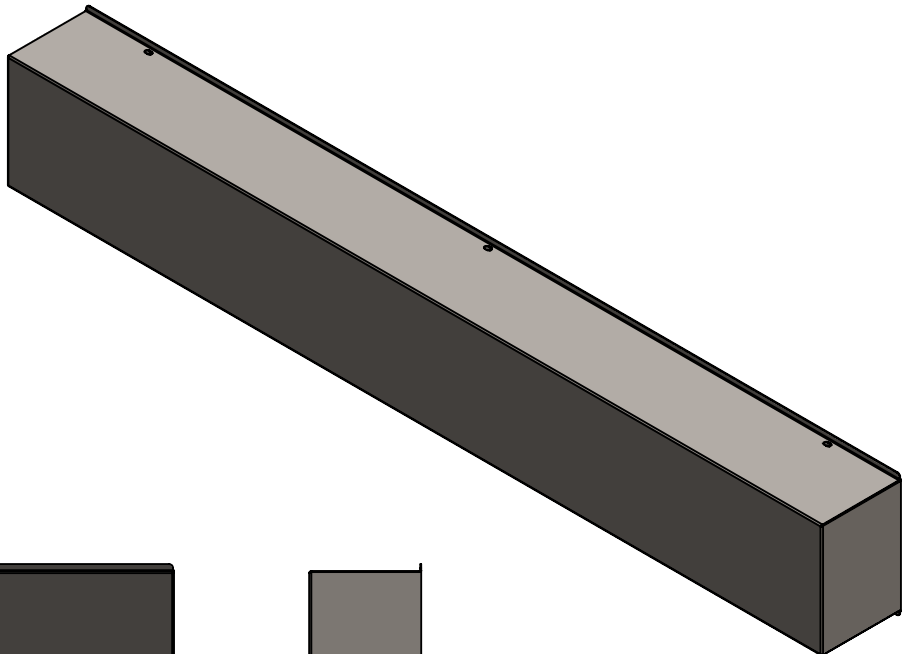

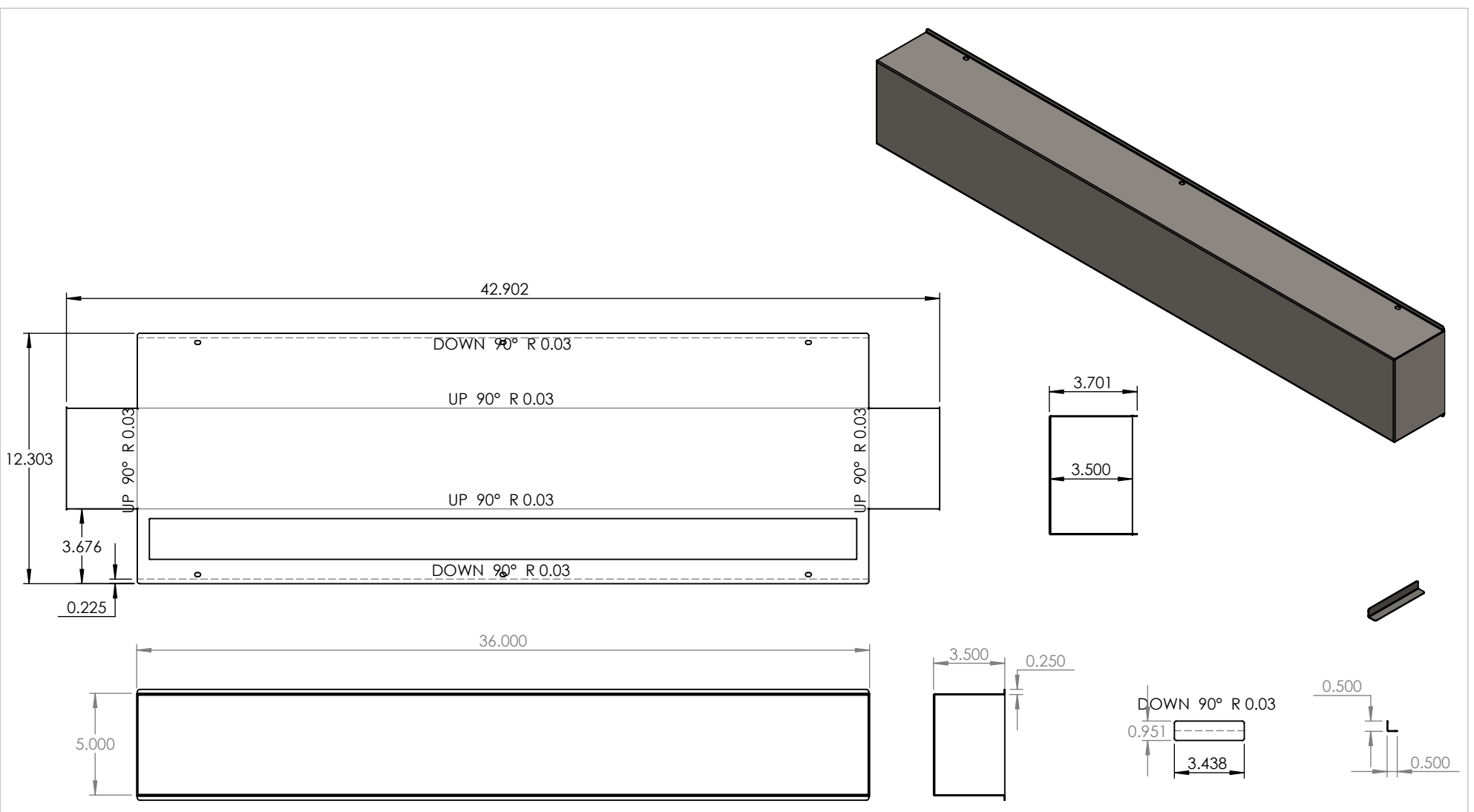

UNLESS OTHERWISE SPECIFIED:

DIMENSIONS ARE IN INCHES
 TOLERANCES:
 FRACTIONAL ±
 ANGULAR: MACH ± BEND ±
 TWO PLACE DECIMAL ±
 THREE PLACE DECIMAL ±

INTERPRET GEOMETRIC TOLERANCING PER:
 MATERIAL
 FINISH

DO NOT SCALE DRAWING

NAME DATE

DRAWN
 CHECKED
 ENG APPR.
 MFG APPR.
 Q.A.
 COMMENTS:

22 GAUGE

TITLE:
 LIN-W-DN-36X5-18LS-BLK-WF-WET-30K

SIZE	DWG. NO.	REV
A		
SCALE: 1:7	WEIGHT:	SHEET 3 OF 6

PROPRIETARY AND CONFIDENTIAL
 THE INFORMATION CONTAINED IN THIS DRAWING IS THE SOLE PROPERTY OF <INSERT COMPANY NAME HERE>. ANY REPRODUCTION IN PART OR AS A WHOLE WITHOUT THE WRITTEN PERMISSION OF <INSERT COMPANY NAME HERE> IS PROHIBITED.

NEXT ASSY	USED ON
APPLICATION	

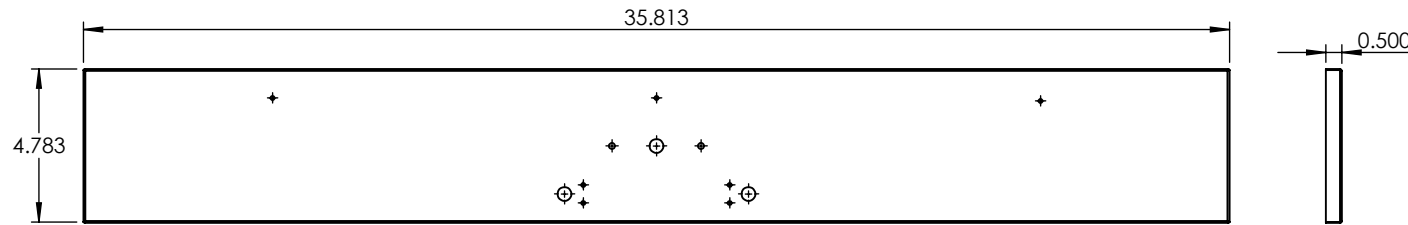
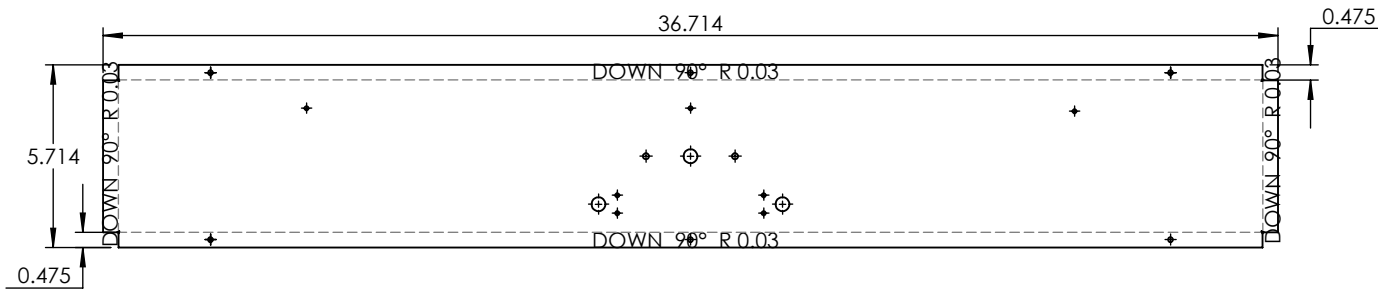
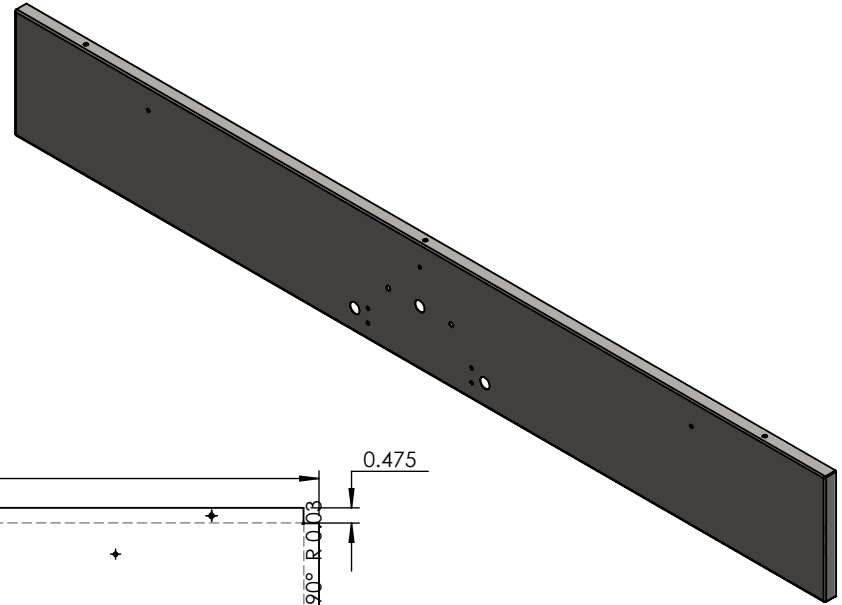

PROPRIETARY AND CONFIDENTIAL
 THE INFORMATION CONTAINED IN THIS DRAWING IS THE SOLE PROPERTY OF <INSERT COMPANY NAME HERE>. ANY REPRODUCTION IN PART OR AS A WHOLE WITHOUT THE WRITTEN PERMISSION OF <INSERT COMPANY NAME HERE> IS PROHIBITED.

NEXT ASSY	USED ON
APPLICATION	

UNLESS OTHERWISE SPECIFIED:
DIMENSIONS ARE IN INCHES
TOLERANCES:
FRACTIONAL ±
ANGULAR: MACH ± BEND ±
TWO PLACE DECIMAL ±
THREE PLACE DECIMAL ±
INTERPRET GEOMETRIC TOLERANCING PER:
MATERIAL
FINISH
DO NOT SCALE DRAWING

	NAME	DATE
DRAWN		
CHECKED		
ENG APPR.		
MFG APPR.		
Q.A.		
COMMENTS:		

22 GAUGE		
TITLE:		
LIN-W-DN-36X5-18LS-BLK-WF-WET-30K		
SIZE	DWG. NO.	REV
A		
SCALE: 1:6	WEIGHT:	SHEET 4 OF 6

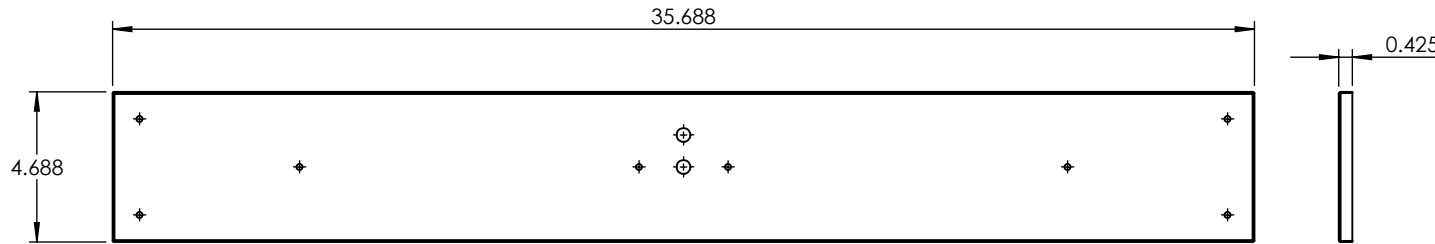
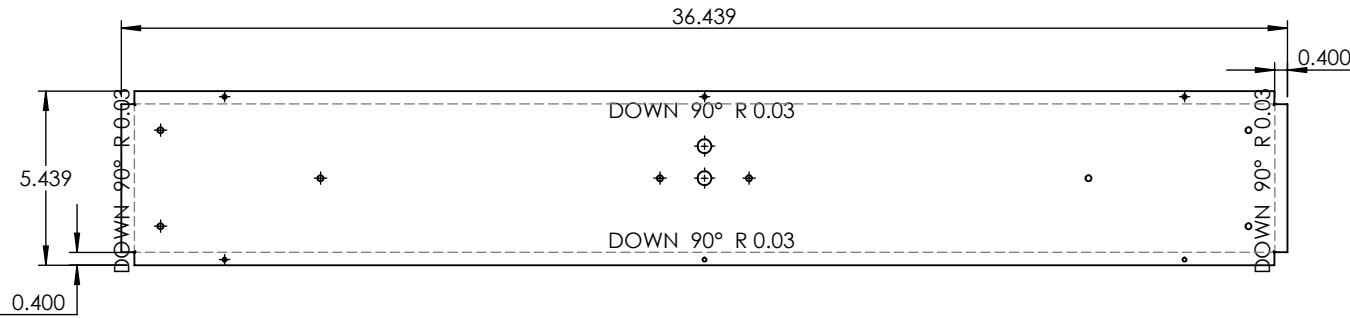
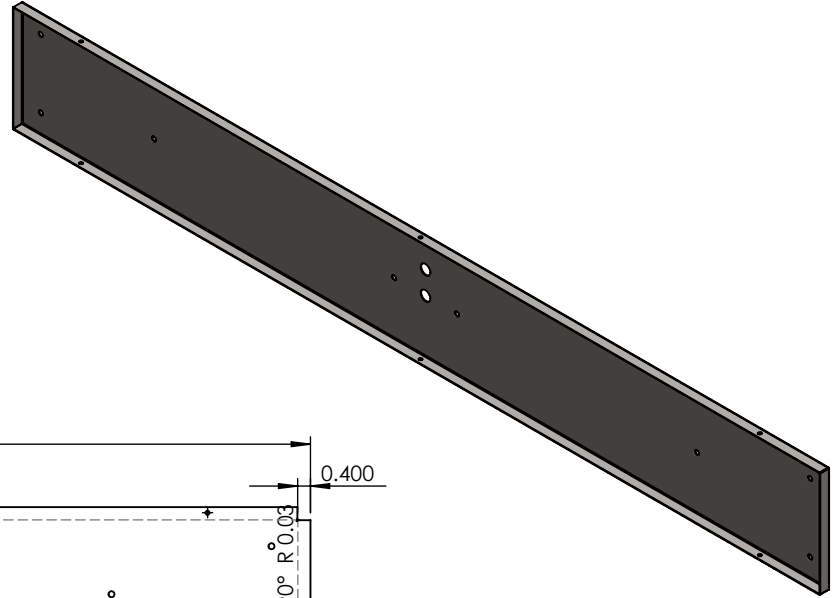

UNLESS OTHERWISE SPECIFIED:		NAME	DATE	22 GAUGE	
DIMENSIONS ARE IN INCHES TOLERANCES: FRACTIONAL ± ANGULAR: MACH ± BEND ± TWO PLACE DECIMAL ± THREE PLACE DECIMAL ±		DRAWN			
INTERPRET GEOMETRIC TOLERANCING PER:		CHECKED		LIN-W-DN-36X5-18LS-BLK-WF-WET-30K	
		ENG APPR.			
MATERIAL		MFG APPR.		SIZE DWG. NO. REV	
		Q.A.		A	
FINISH		COMMENTS:		SCALE: 1:6 WEIGHT: SHEET 5 OF 6	
DO NOT SCALE DRAWING					

PROPRIETARY AND CONFIDENTIAL
THE INFORMATION CONTAINED IN THIS DRAWING IS THE SOLE PROPERTY OF <INSERT COMPANY NAME HERE>. ANY REPRODUCTION IN PART OR AS A WHOLE WITHOUT THE WRITTEN PERMISSION OF <INSERT COMPANY NAME HERE> IS PROHIBITED.

NEXT ASSY	USED ON
APPLICATION	

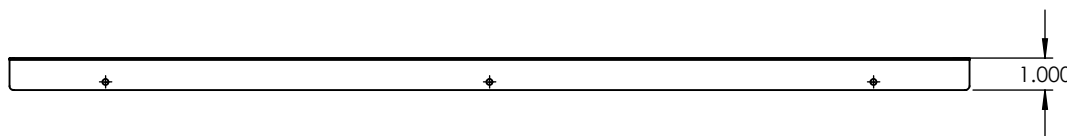
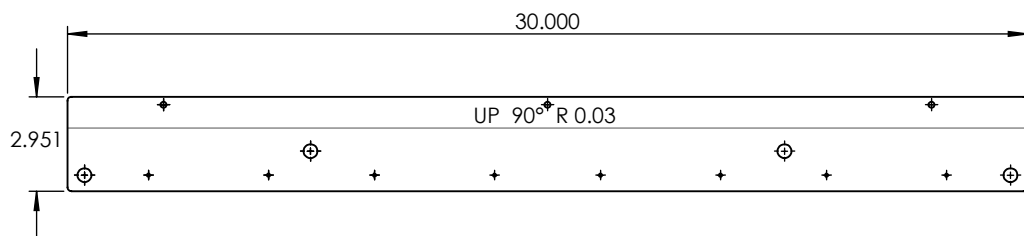
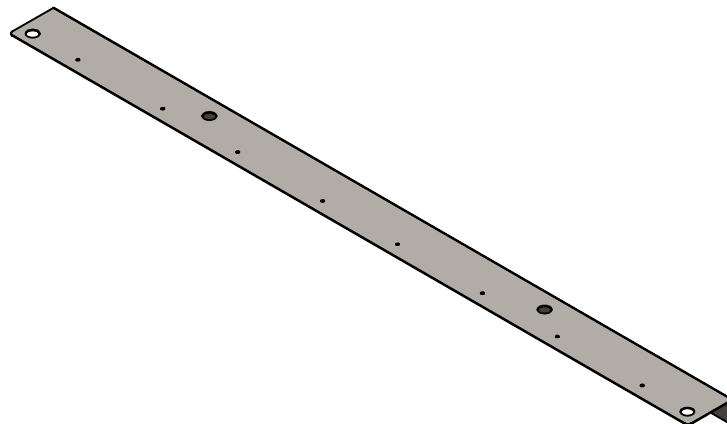

UNLESS OTHERWISE SPECIFIED:

DIMENSIONS ARE IN INCHES
TOLERANCES:
FRACTIONAL ±
ANGULAR: MACH ± BEND ±
TWO PLACE DECIMAL ±
THREE PLACE DECIMAL ±

INTERPRET GEOMETRIC
TOLERANCING PER:

MATERIAL

FINISH

DO NOT SCALE DRAWING

NAME

DATE

22 GAUGE

TITLE:

LIN-W-DN-36X5-18LS-BLK-WF-WET-30K

DRAWN

CHECKED

ENG APPR.

MFG APPR.

Q.A.

COMMENTS:

SIZE
A

DWG. NO.

REV

SCALE: 1:6

WEIGHT:

SHEET 6 OF 6

PROPRIETARY AND CONFIDENTIAL
THE INFORMATION CONTAINED IN THIS DRAWING IS THE SOLE PROPERTY OF <INSERT COMPANY NAME HERE>. ANY REPRODUCTION IN PART OR AS A WHOLE WITHOUT THE WRITTEN PERMISSION OF <INSERT COMPANY NAME HERE> IS PROHIBITED.

NEXT ASSY	USED ON
APPLICATION	