

ITEM NO.	PART NUMBER	DESCRIPTION	QTY.	CUT
1	LH40LEDC-LV-BLK-99-ARM-DIM-40K-SPHERE	SPUN ALUMINUM 0.125"	1	
2	LH40LEDC-LV-BLK-99-ARM-DIM-40K-SPUN CANOPY	SPUN ALUMINUM 0.125"	1	
3	LH40LEDC-LV-BLK-99-ARM-DIM-40K-SPUN FIREPLATE	SPUN ALUMINUM 0.125"	1	
4	LH40LEDC-LV-BLK-99-ARM-DIM-40K-SHADE	SPUN ALUMINUM 0.080"	1	
5	LH40LEDC-LV-BLK-99-ARM-DIM-40K-ARM COVER	SPUN ALUMINUM 0.0635"	1	
6	LH40LEDC-LV-BLK-99-ARM-DIM-40K-SPHERE MOUNT	SPUN ALUMINUM 0.0635"	1	
7	LH40LEDC-LV-BLK-99-ARM-DIM-40K-BELL MOUNT	SPUN ALUMINUM 0.0635"	1	
8	LH40LEDC-LV-BLK-99-ARM-DIM-40K-SPHERE SLEEVE	SPUN ALUMINUM 0.080"	1	
9	LH40LEDC-LV-BLK-99-ARM-DIM-40K-CANOPY BRACKET	ALUMINUM 0.500" PLATE	1	
10	LH40LEDC-LV-BLK-99-ARM-DIM-40K-TUBE BRACKET	ALUMINUM 0.500" PLATE	1	
11	LH40LEDC-LV-BLK-99-ARM-DIM-40K-LED PLATE	ALUMINUM 0.0635"	1	
12	LH40LEDC-LV-BLK-99-ARM-DIM-40K-TUBE ARM	1 1/2" ALUMINUM TUBE	1	
13	LH40LEDC-LV-BLK-99-ARM-DIM-40K-0.500" ROUND BAR	1/2" ALUMINUM ROUND BAR	4	
14	LH40LEDC-LV-BLK-99-ARM-DIM-40K-0.500" ROUND BAR	1/2" ALUMINUM ROUND BAR	4	
15	LH40LEDC-LV-BLK-99-ARM-DIM-40K-TUBE LENS	ACRYLIC	1	
16	55MM HEXAGON HEAT SINK	HEAT SINK	4	
17	HATCH-LC25-0700Z-UNV-Q	DRIVER	2	
18	Alttailed_PCND_1500_110B-10 WATT	LED	4	

UNLESS OTHERWISE SPECIFIED:

DIMENSIONS ARE IN INCHES  
 TOLERANCES:  
 FRACTIONAL ± .003  
 ANGULAR: MACH ± .01 BEND ±  
 TWO PLACE DECIMAL ±  
 THREE PLACE DECIMAL ±.001

INTERPRET GEOMETRIC  
 TOLERANCING PER:  
 MATERIAL

FINISH

	NAME	DATE
DRAWN		
CHECKED		
ENG APPR.		
MFG APPR.		
Q.A.		

COMMENTS:

TITLE:  
**LH40LEDC-LV-BLK-99-ARM-DIM-40K**

SIZE DWG. NO. REV  
**A** TICKET 26950

SCALE: 1:11 WEIGHT: SHEET 1 OF 14

**EVERGREEN LIGHTING**

ALL BEND RADIUS .030"

APPLICATION

DO NOT SCALE DRAWING

5

4

3

2

1

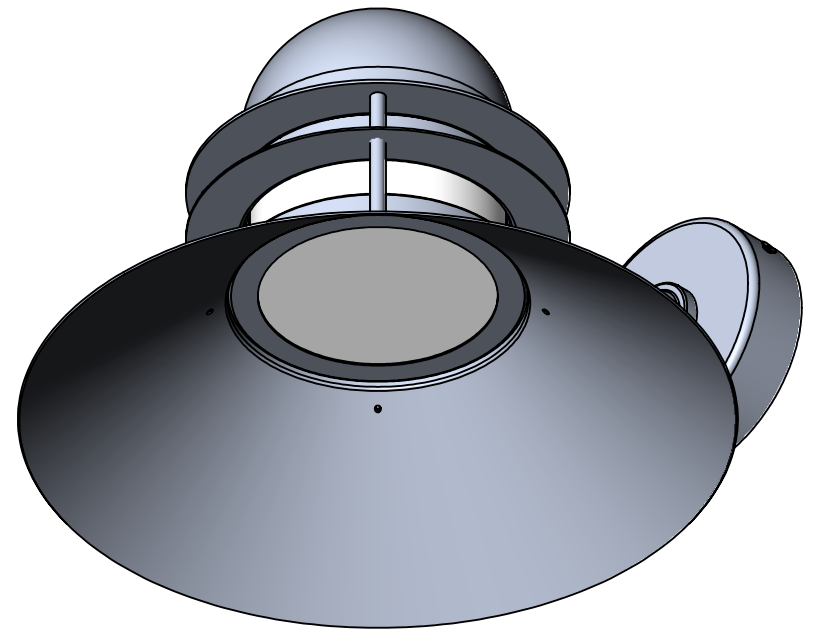
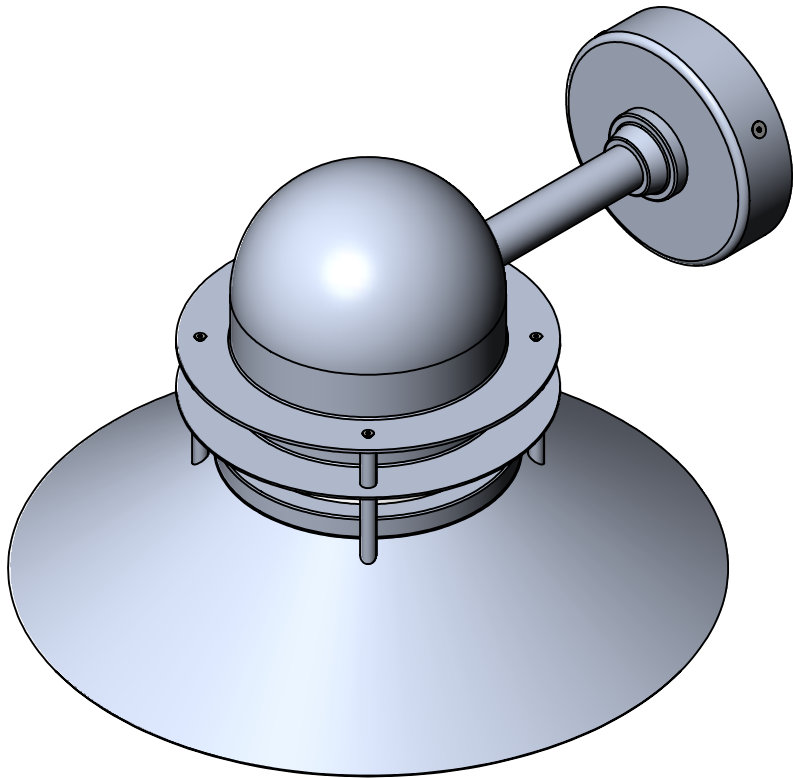
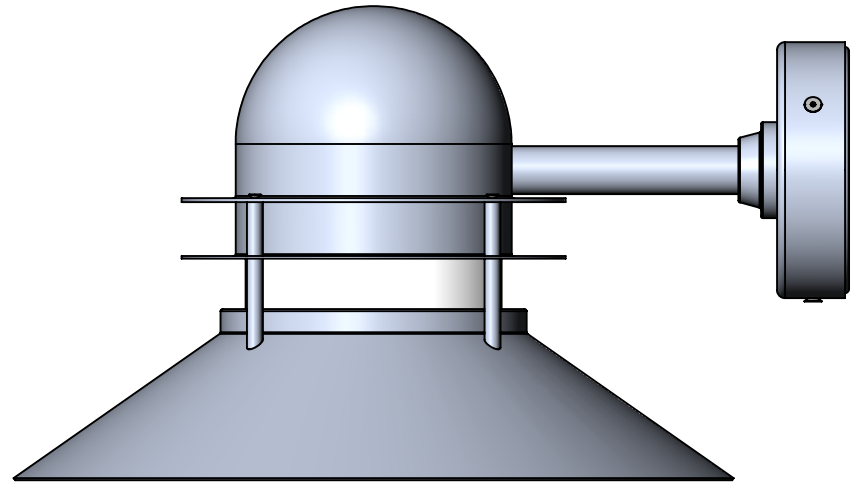
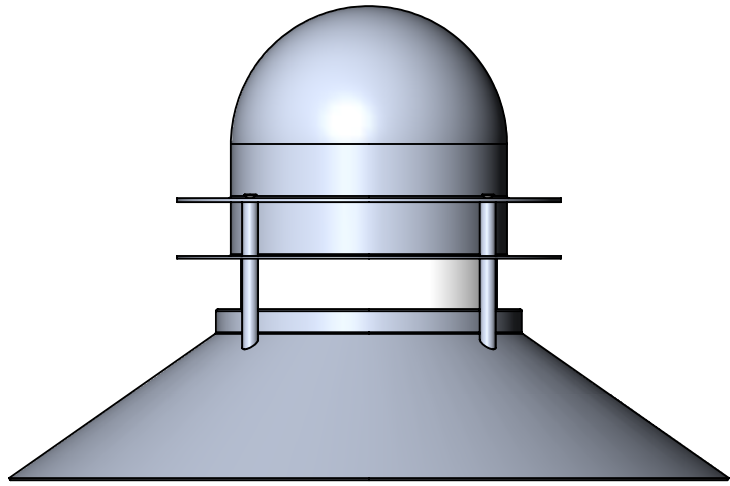

HOUSING HELD TOGETHER WITH 4 BOLTS THROUGH VERTICAL  
ROUND BARS

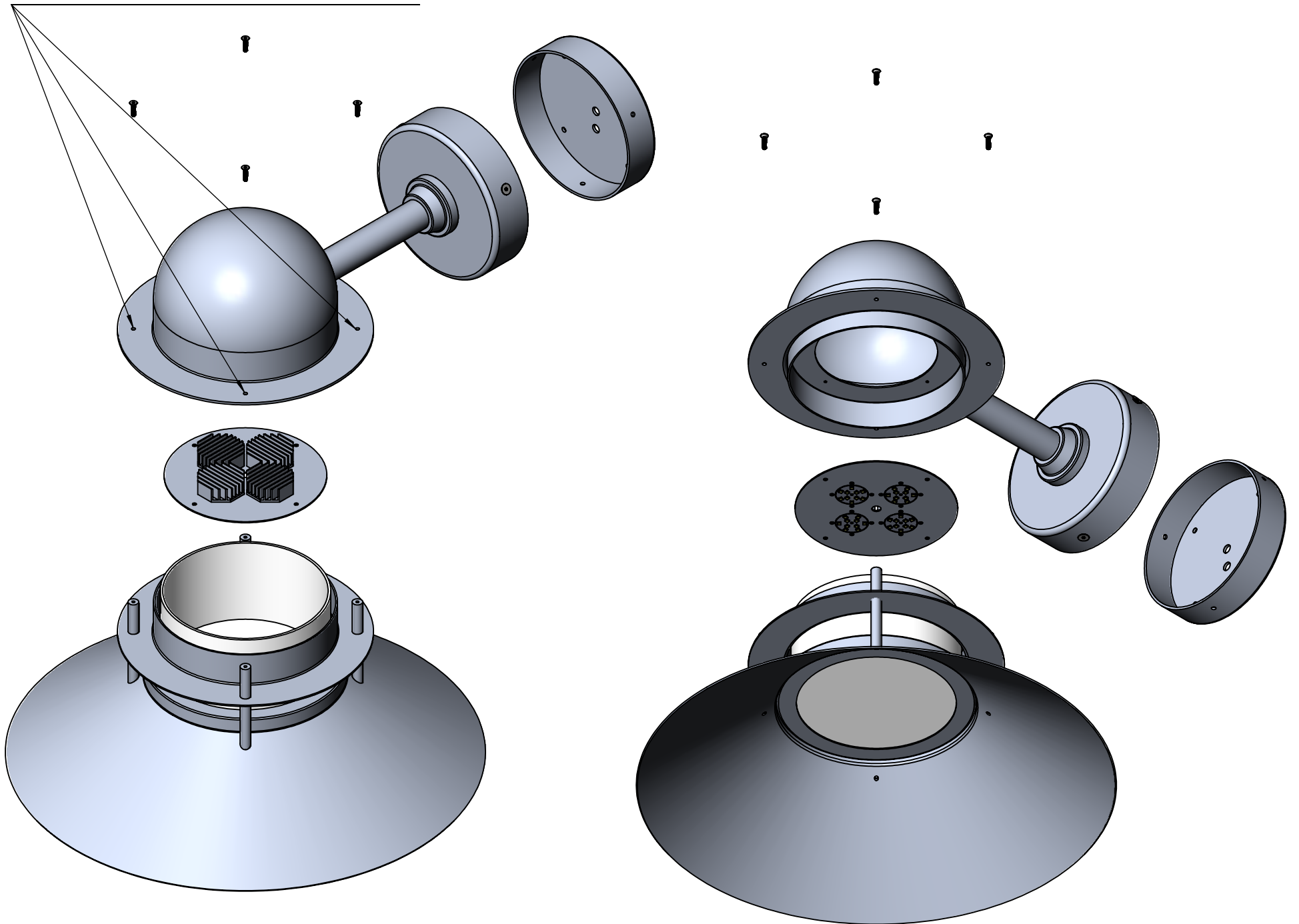

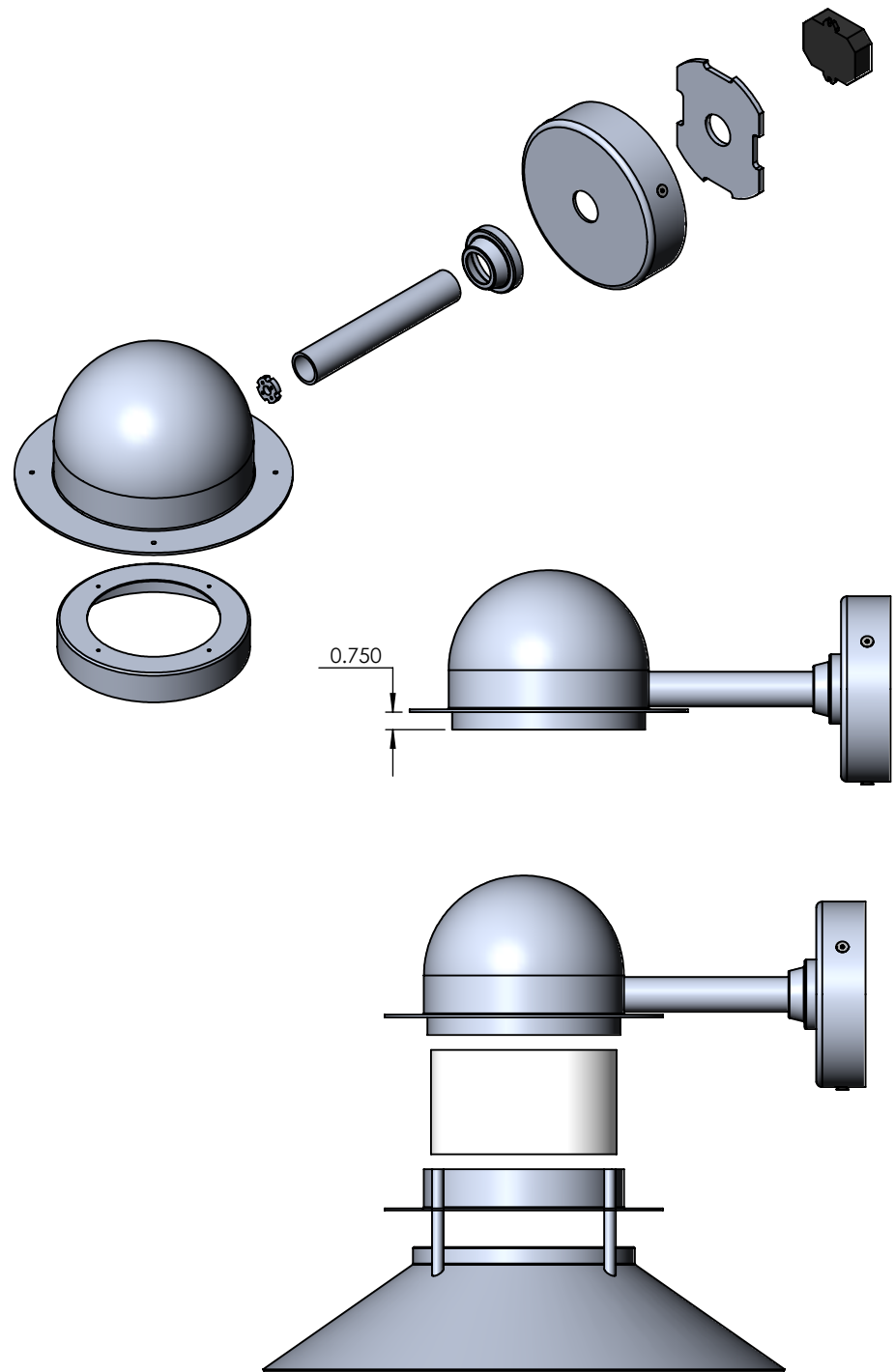
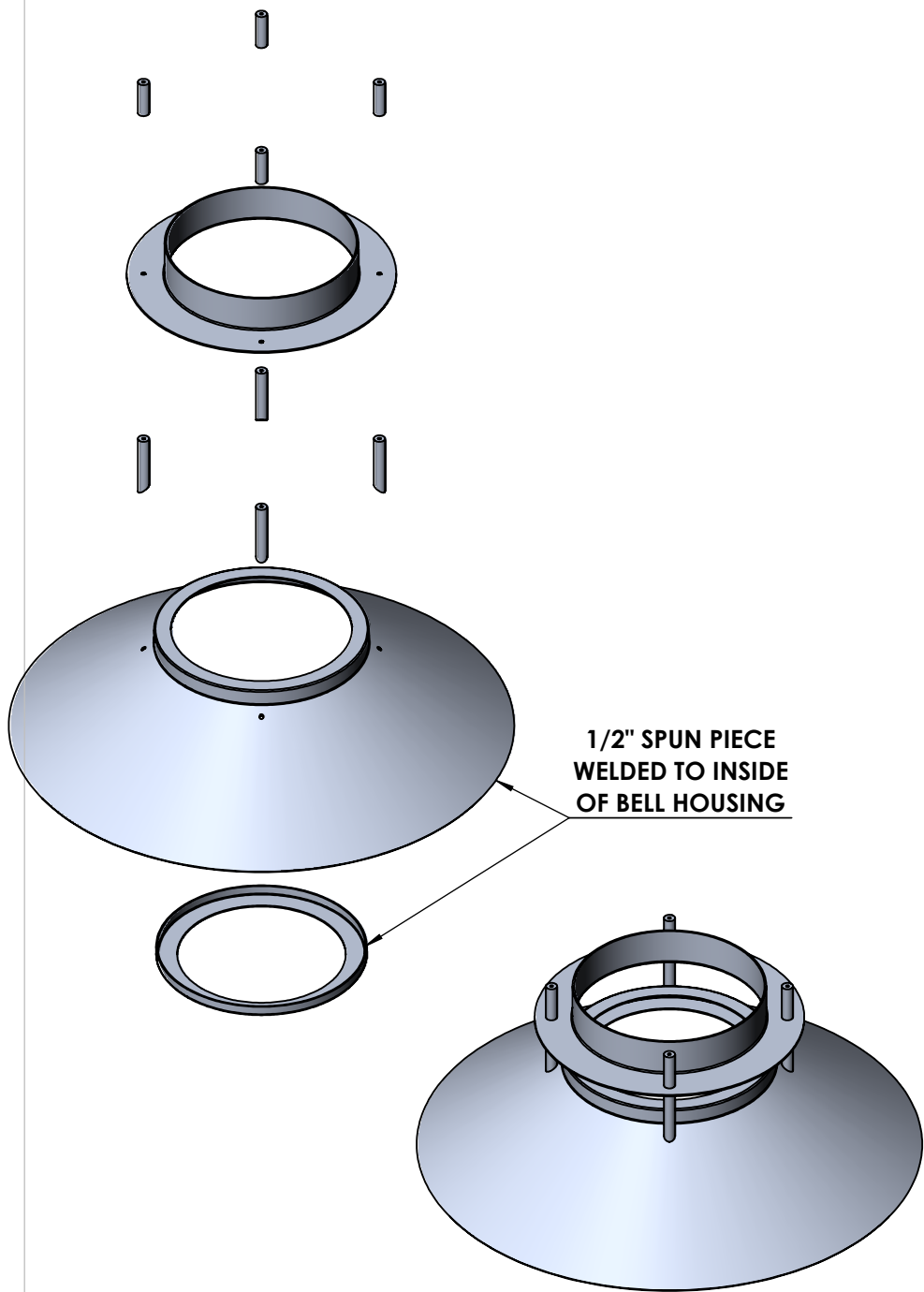

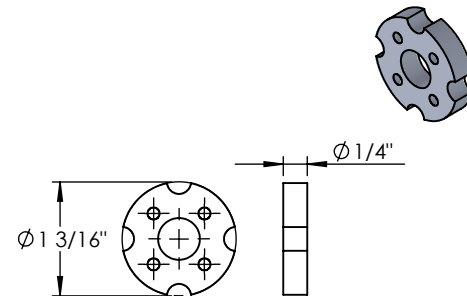
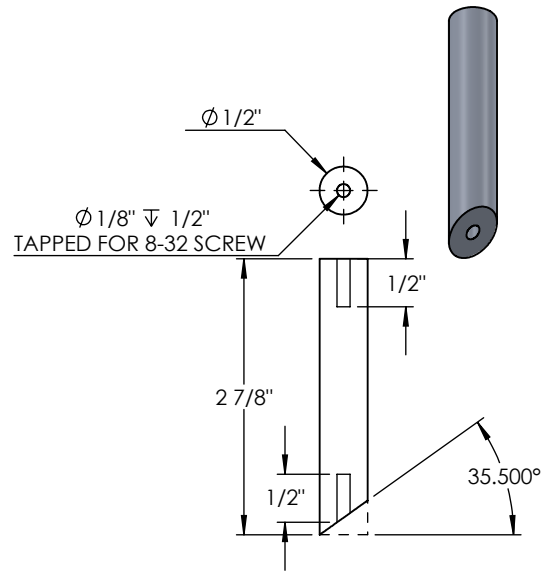
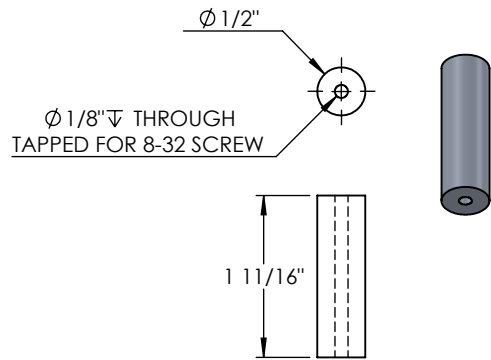

**PROPRIETARY AND CONFIDENTIAL**  
 THE INFORMATION CONTAINED IN THIS DRAWING IS THE SOLE PROPERTY OF <INSERT COMPANY NAME HERE>. ANY REPRODUCTION IN PART OR AS A WHOLE WITHOUT THE WRITTEN PERMISSION OF <INSERT COMPANY NAME HERE> IS PROHIBITED.

NEXT ASSY	USED ON
APPLICATION	

UNLESS OTHERWISE SPECIFIED:	NAME	DATE
DIMENSIONS ARE IN INCHES	DRAWN	
TOLERANCES:	CHECKED	
FRACTIONAL ±	ENG APPR.	
ANGULAR: MACH ± BEND ±	MFG APPR.	
TWO PLACE DECIMAL ±	Q.A.	
THREE PLACE DECIMAL ±	COMMENTS:	
INTERPRET GEOMETRIC TOLERANCING PER:		
MATERIAL		
FINISH		
DO NOT SCALE DRAWING		

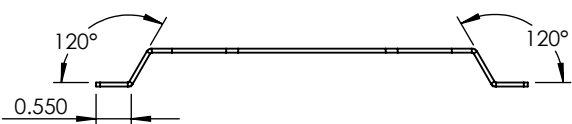
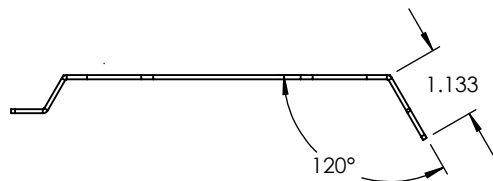
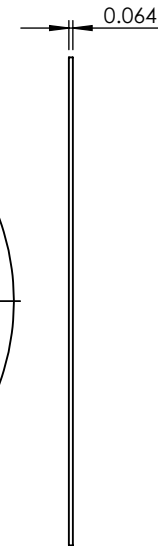
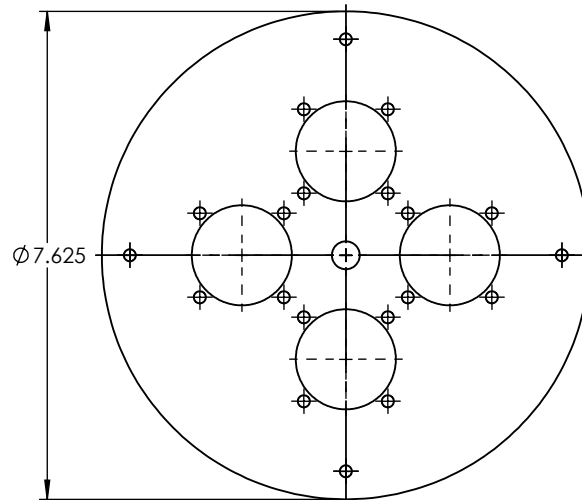
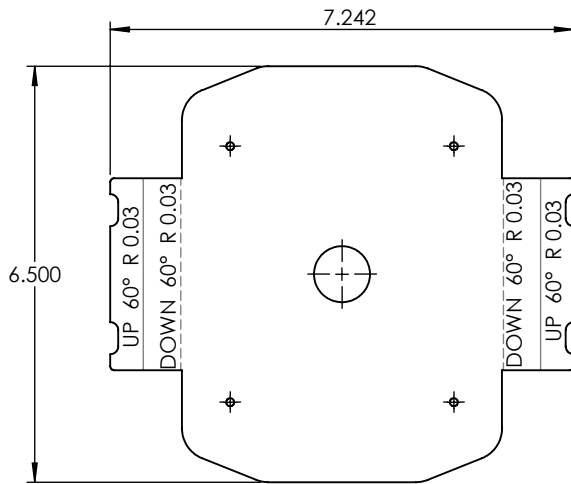
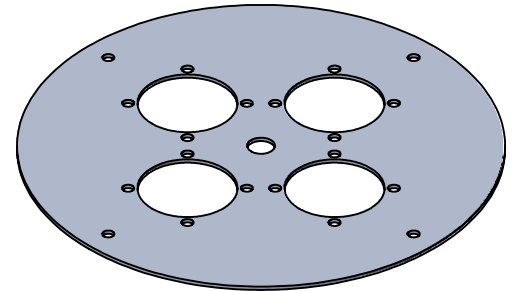
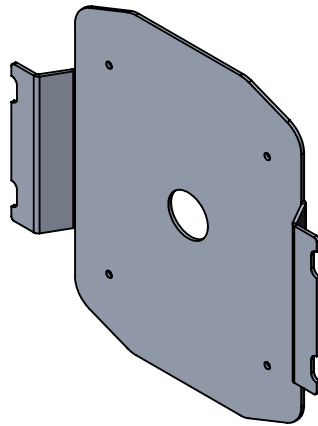

SPUN ALUMINUM 0.125"		
TITLE:		
LH40LEDL-LV-BLK-99-ARM-DIM-40K		
SIZE	DWG. NO.	REV
<b>A</b>		
SCALE: 1:4	WEIGHT:	SHEET 5 OF 14



UNLESS OTHERWISE SPECIFIED:		NAME	DATE	ALUMINUM 0.0635"	
DIMENSIONS ARE IN INCHES		DRAWN		TITLE:	
TOLERANCES:		CHECKED		LH40LEDC-LV-BLK-99-ARM-DIM-40K	
FRACTIONAL ±		ENG APPR.		SIZE DWG. NO. REV	
ANGULAR: MACH ± BEND ±		MFG APPR.		SCALE: 1:3 WEIGHT: SHEET 6 OF 14	
TWO PLACE DECIMAL ±		Q.A.			
THREE PLACE DECIMAL ±		COMMENTS:			
INTERPRET GEOMETRIC TOLERANCING PER:					
MATERIAL					
FINISH					
APPLICATION					
DO NOT SCALE DRAWING					

**PROPRIETARY AND CONFIDENTIAL**  
 THE INFORMATION CONTAINED IN THIS DRAWING IS THE SOLE PROPERTY OF <INSERT COMPANY NAME HERE>. ANY REPRODUCTION IN PART OR AS A WHOLE WITHOUT THE WRITTEN PERMISSION OF <INSERT COMPANY NAME HERE> IS PROHIBITED.

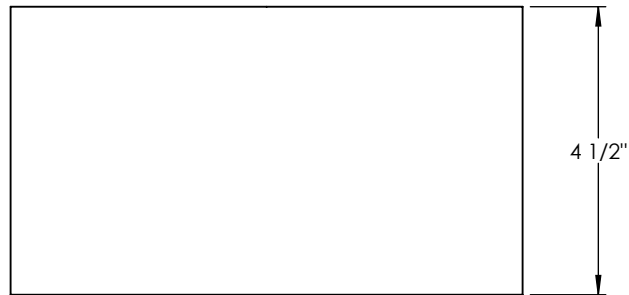
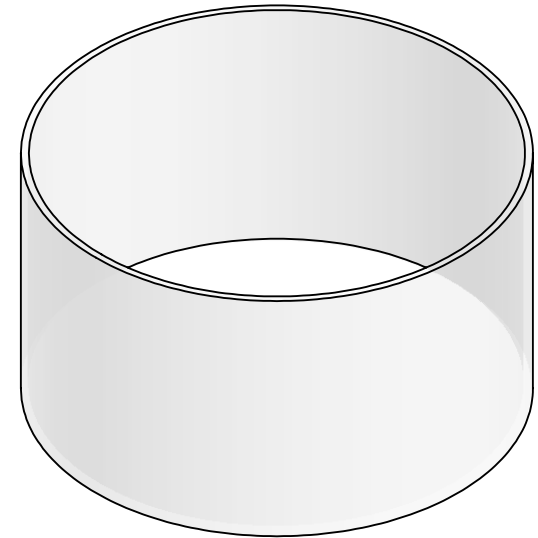
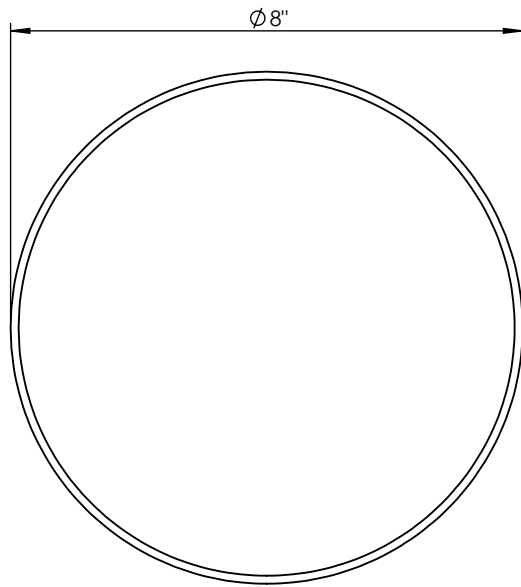
NEXT ASSY	USED ON
APPLICATION	
DO NOT SCALE DRAWING	



**PROPRIETARY AND CONFIDENTIAL**  
 THE INFORMATION CONTAINED IN THIS DRAWING IS THE SOLE PROPERTY OF <INSERT COMPANY NAME HERE>. ANY REPRODUCTION IN PART OR AS A WHOLE WITHOUT THE WRITTEN PERMISSION OF <INSERT COMPANY NAME HERE> IS PROHIBITED.

		UNLESS OTHERWISE SPECIFIED:		NAME	DATE	ACRYLIC	
		DIMENSIONS ARE IN INCHES TOLERANCES: FRACTIONAL ± ANGULAR: MACH ± BEND ± TWO PLACE DECIMAL ± THREE PLACE DECIMAL ±	DRAWN				
		INTERPRET GEOMETRIC TOLERANCING PER:	CHECKED			LH40LEDG-LV-BLK-99-ARM-DIM-40K	
		MATERIAL	ENG APPR.			SIZE DWG. NO. REV	
	NEXT ASSY	FINISH	MFG APPR.			A	
	USED ON		Q.A.			SCALE: 1:3 WEIGHT: SHEET 7 OF 14	
	APPLICATION	DO NOT SCALE DRAWING	COMMENTS:				

ITEM NO.	PART NUMBER	DESCRIPTION	QTY.
1	LH20LED-LV-AB-41K-SPHERE	SPUN ALUMINUM 0.125"	1

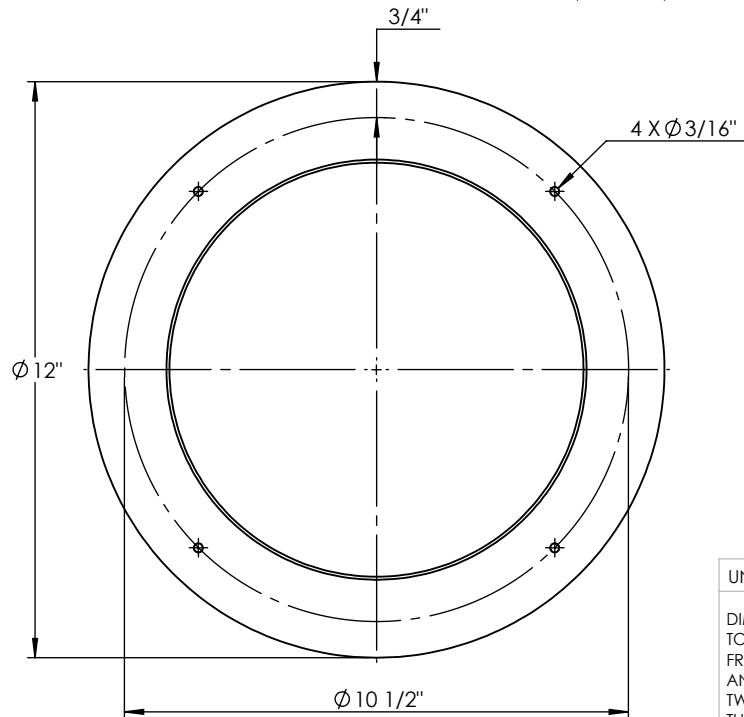
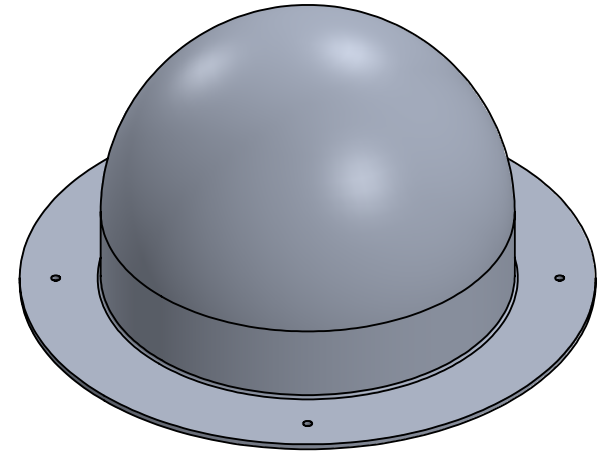
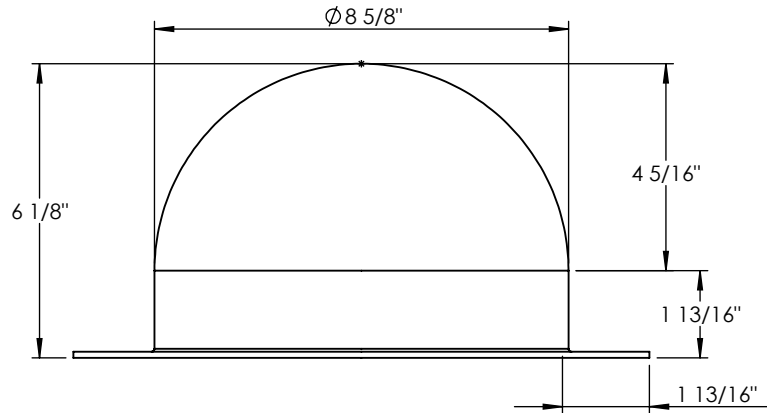

UNLESS OTHERWISE SPECIFIED:		NAME	DATE	SPUN ALUMINUM 0.125"	
DIMENSIONS ARE IN INCHES TOLERANCES: FRACTIONAL ± ANGULAR: MACH ± BEND ± TWO PLACE DECIMAL ± THREE PLACE DECIMAL ±		DRAWN			
INTERPRET GEOMETRIC TOLERANCING PER:		CHECKED		LH40LEDC-LV-BLK-99-ARM-DIM-40K	
MATERIAL		ENG APPR.		SIZE	DWG. NO.
FINISH		MFG APPR.		<b>A</b>	REV
NEXT ASSY		Q.A.		SCALE: 1:4 WEIGHT: SHEET 8 OF 14	
USED ON		COMMENTS:			
APPLICATION		DO NOT SCALE DRAWING			

**PROPRIETARY AND CONFIDENTIAL**  
THE INFORMATION CONTAINED IN THIS DRAWING IS THE SOLE PROPERTY OF <INSERT COMPANY NAME HERE>. ANY REPRODUCTION IN PART OR AS A WHOLE WITHOUT THE WRITTEN PERMISSION OF <INSERT COMPANY NAME HERE> IS PROHIBITED.



ITEM NO.	PART NUMBER	DESCRIPTION	QTY.
1	LH40LEDC-LV-BLK-99-ARM-DIM-40K-SPHERE SLEEVE	SPUN ALUMINUM 0.080"	1

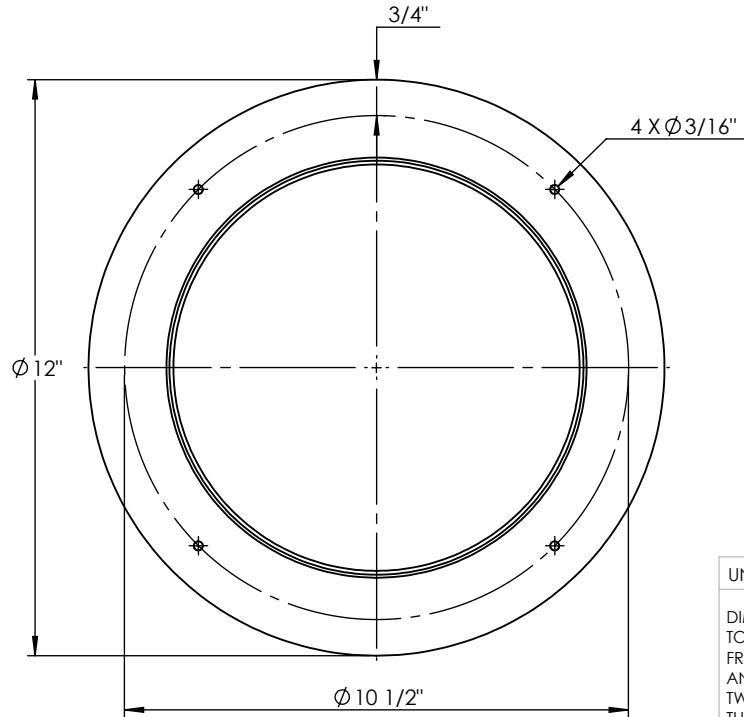
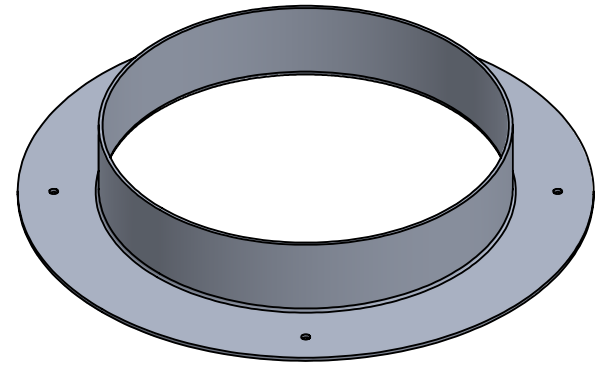
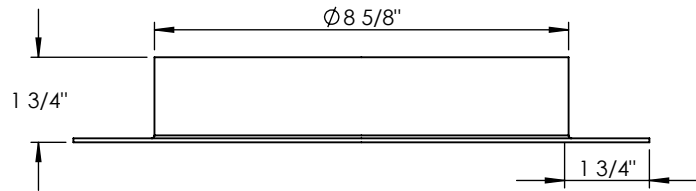

UNLESS OTHERWISE SPECIFIED:  DIMENSIONS ARE IN INCHES TOLERANCES: FRACTIONAL ± ANGULAR: MACH ± BEND ± TWO PLACE DECIMAL ± THREE PLACE DECIMAL ±		NAME	DATE	SPUN ALUMINUM 0.080"		
	DRAWN			TITLE:		
	CHECKED			LH40LEDC-LV-BLK-99-ARM-DIM-40K		
	ENG APPR.			SIZE	DWG. NO.	REV
	MFG APPR.			<b>A</b>		
INTERPRET GEOMETRIC TOLERANCING PER:	Q.A.			SCALE: 1:4	WEIGHT:	SHEET 9 OF 14
MATERIAL	COMMENTS:					
FINISH						
APPLICATION						

**PROPRIETARY AND CONFIDENTIAL**  
THE INFORMATION CONTAINED IN THIS DRAWING IS THE SOLE PROPERTY OF <INSERT COMPANY NAME HERE>. ANY REPRODUCTION IN PART OR AS A WHOLE WITHOUT THE WRITTEN PERMISSION OF <INSERT COMPANY NAME HERE> IS PROHIBITED.

NEXT ASSY	USED ON
APPLICATION	

DO NOT SCALE DRAWING

ITEM NO.	PART NUMBER	DESCRIPTION	QTY.
1	LH40LEDC-LV-BLK-99-ARM-DIM-40K-SHADE	SPUN ALUMINUM 0.080"	1

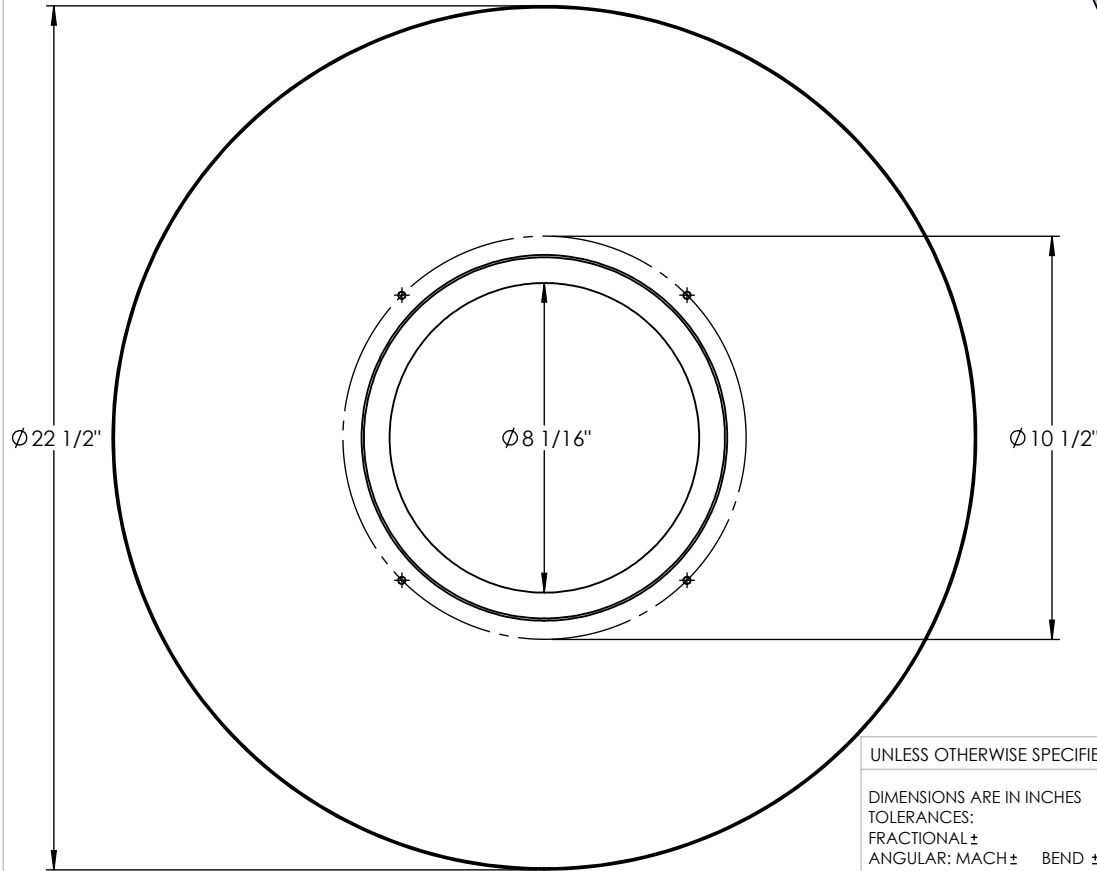
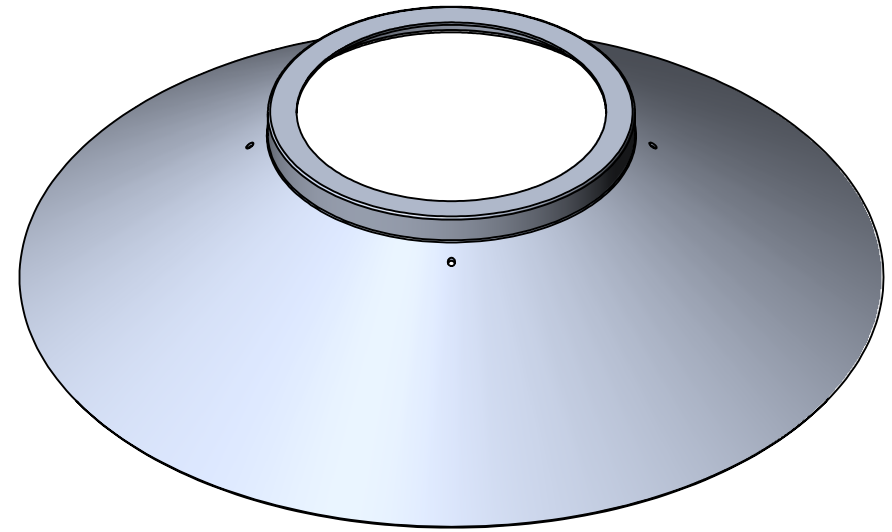
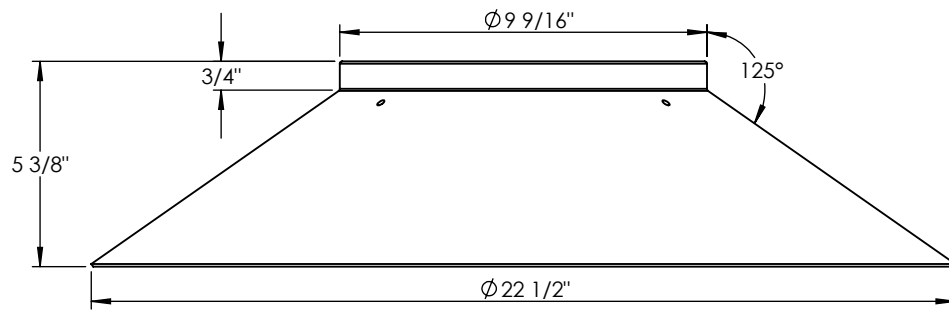

UNLESS OTHERWISE SPECIFIED:  
 DIMENSIONS ARE IN INCHES  
 TOLERANCES:  
 FRACTIONAL ±  
 ANGULAR: MACH ± BEND ±  
 TWO PLACE DECIMAL ±  
 THREE PLACE DECIMAL ±

	NAME	DATE
DRAWN		
CHECKED		
ENG APPR.		
MFG APPR.		
Q.A.		

SPUN ALUMINUM 0.080"  
 TITLE:  
 LH40LEDC-LV-BLK-99-ARM-DIM-40K

**PROPRIETARY AND CONFIDENTIAL**  
 THE INFORMATION CONTAINED IN THIS DRAWING IS THE SOLE PROPERTY OF <INSERT COMPANY NAME HERE>. ANY REPRODUCTION IN PART OR AS A WHOLE WITHOUT THE WRITTEN PERMISSION OF <INSERT COMPANY NAME HERE> IS PROHIBITED.

NEXT ASSY	USED ON
APPLICATION	

INTERPRET GEOMETRIC TOLERANCING PER:  
 MATERIAL  
 FINISH  
 DO NOT SCALE DRAWING

COMMENTS:

SIZE	DWG. NO.	REV
<b>A</b>		
SCALE: 1:5	WEIGHT:	SHEET 10 OF 14

ITEM NO.	PART NUMBER	DESCRIPTION	QTY.
1	LH40LEDC-LV-BLK-99-ARM-DIM-40K-SPHERE MOUNT	SPUN ALUMINUM 0.0635"	1

ITEM NO.	PART NUMBER	DESCRIPTION	QTY.
1	LH40LEDC-LV-BLK-99-ARM-DIM-40K-BELL MOUNT	SPUN ALUMINUM 0.0635"	1

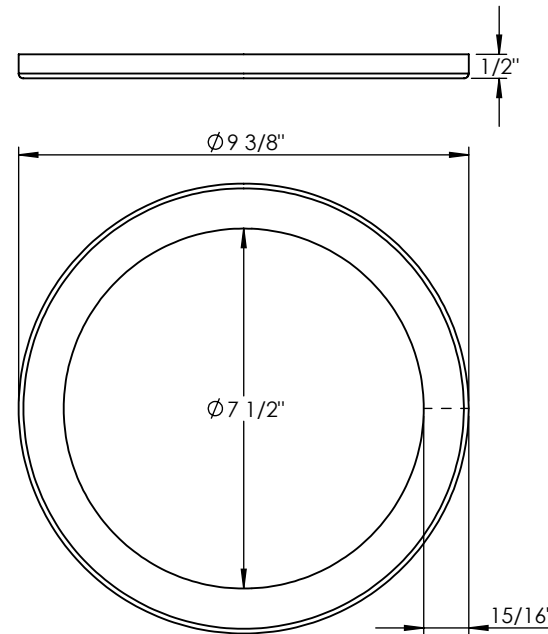
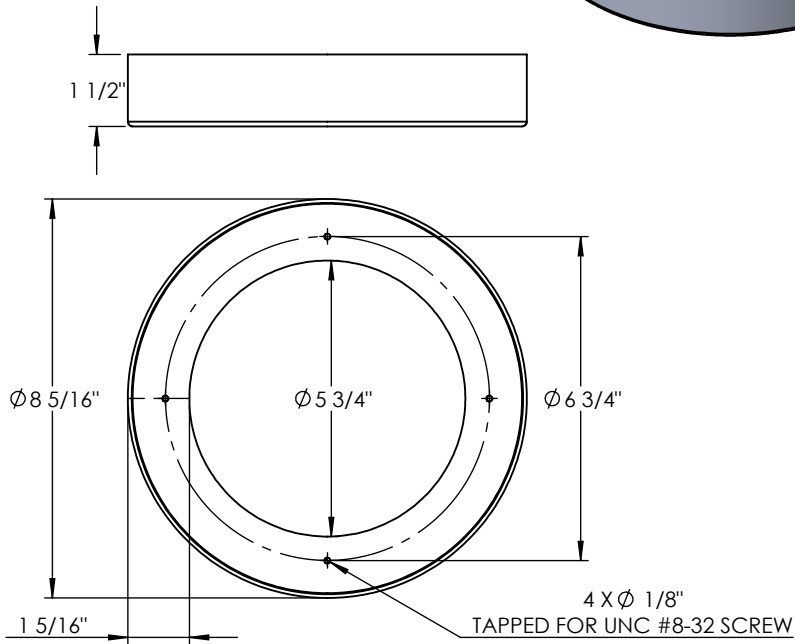
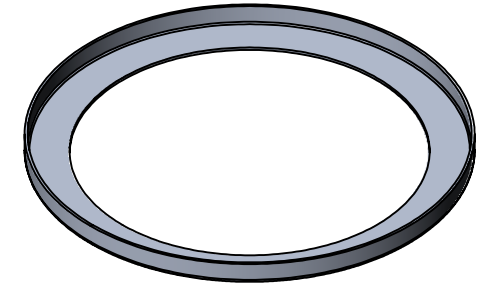
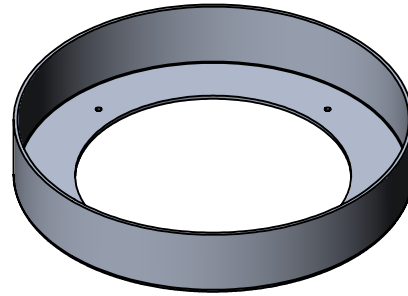

**PROPRIETARY AND CONFIDENTIAL**  
 THE INFORMATION CONTAINED IN THIS DRAWING IS THE SOLE PROPERTY OF <INSERT COMPANY NAME HERE>. ANY REPRODUCTION IN PART OR AS A WHOLE WITHOUT THE WRITTEN PERMISSION OF <INSERT COMPANY NAME HERE> IS PROHIBITED.

		UNLESS OTHERWISE SPECIFIED:		NAME	DATE
		DIMENSIONS ARE IN INCHES	DRAWN		
		TOLERANCES:	CHECKED		
		FRACTIONAL $\pm$	ENG APPR.		
		ANGULAR: MACH $\pm$ BEND $\pm$	MFG APPR.		
		TWO PLACE DECIMAL $\pm$	Q.A.		
		THREE PLACE DECIMAL $\pm$	COMMENTS:		
		INTERPRET GEOMETRIC TOLERANCING PER:			
		MATERIAL			
		FINISH			
NEXT ASSY	USED ON				
APPLICATION		DO NOT SCALE DRAWING			

SPUN ALUMINUM 0.0635"

TITLE:  
LH40LEDC-LV-BLK-99-ARM-DIM-40K

SIZE DWG. NO. REV  
**A**

SCALE: 1:4 WEIGHT: SHEET 11 OF 14

ITEM NO.	PART NUMBER	DESCRIPTION	QTY.
1	LH20LED-LV-WH-ARM-8"CNPY-40K-ARM COVER	SPUN ALUMINUM 0.0635"	1

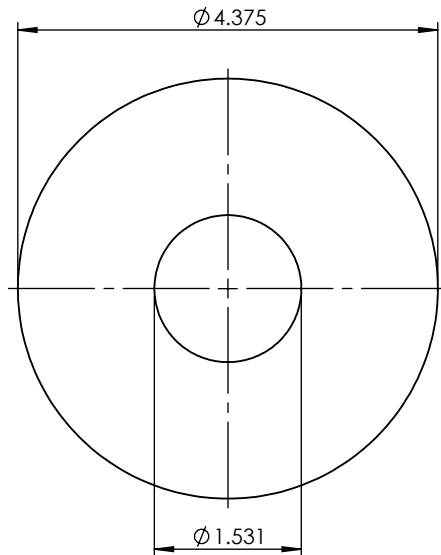
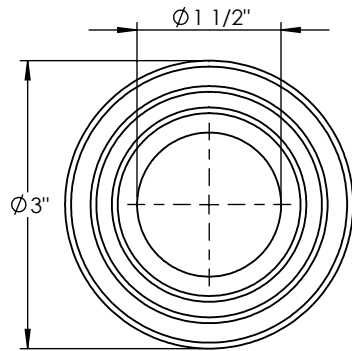
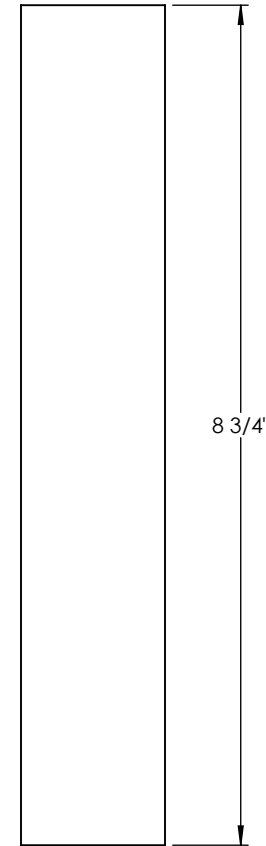
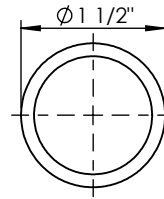
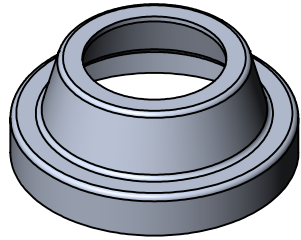
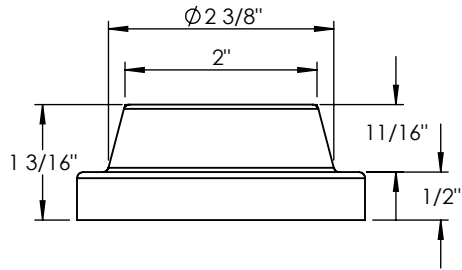

UNLESS OTHERWISE SPECIFIED:

DIMENSIONS ARE IN INCHES  
 TOLERANCES:  
 FRACTIONAL ±  
 ANGULAR: MACH ± BEND ±  
 TWO PLACE DECIMAL ±  
 THREE PLACE DECIMAL ±

INTERPRET GEOMETRIC TOLERANCING PER:

MATERIAL

FINISH

DO NOT SCALE DRAWING

NAME

DATE

SPUN ALUMINUM 0.0635"

TITLE:

LH40LEDC-LV-BLK-99-ARM-DIM-40K

SIZE DWG. NO.

REV

**A**

SCALE: 1:2

WEIGHT:

SHEET 12 OF 14

**PROPRIETARY AND CONFIDENTIAL**  
 THE INFORMATION CONTAINED IN THIS DRAWING IS THE SOLE PROPERTY OF <INSERT COMPANY NAME HERE>. ANY REPRODUCTION IN PART OR AS A WHOLE WITHOUT THE WRITTEN PERMISSION OF <INSERT COMPANY NAME HERE> IS PROHIBITED.

NEXT ASSY

USED ON

APPLICATION

5

4

3

2

1

ITEM NO.	PART NUMBER	DESCRIPTION	QTY.
1	HD-ARM1-12W-MBK-WF-10"-30K-SPUN CANOPY	SPUN ALUMINUM 0.125"	1

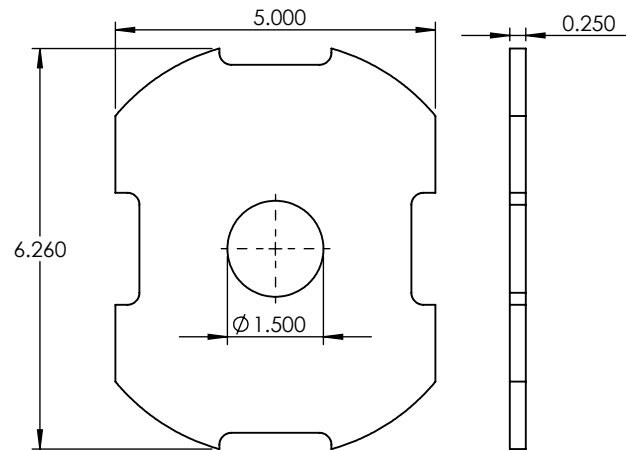
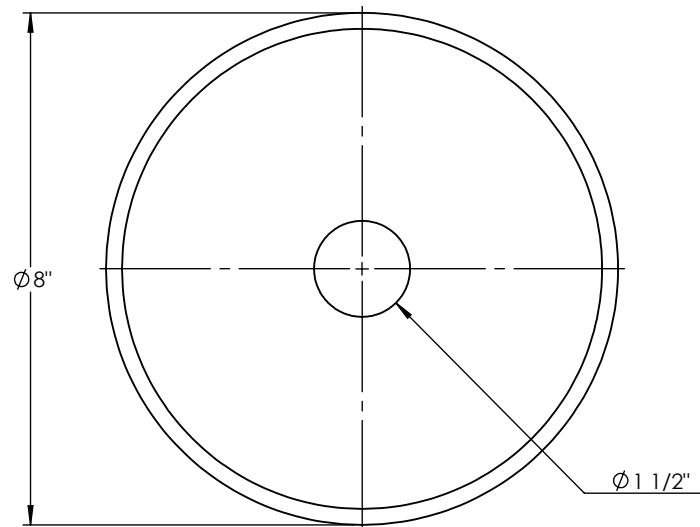
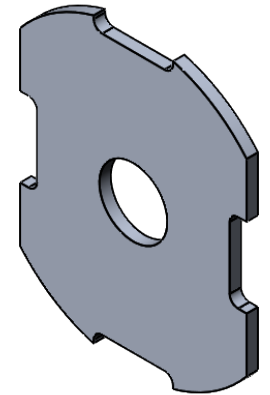
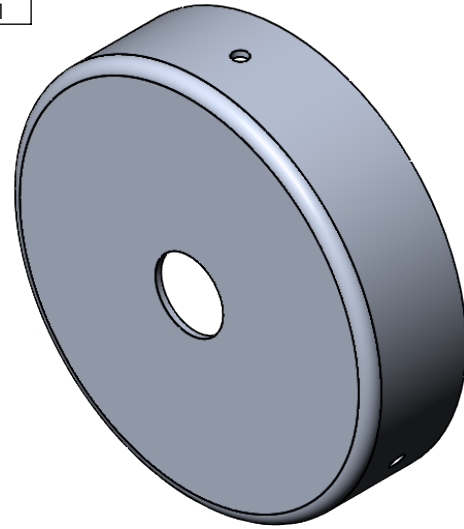
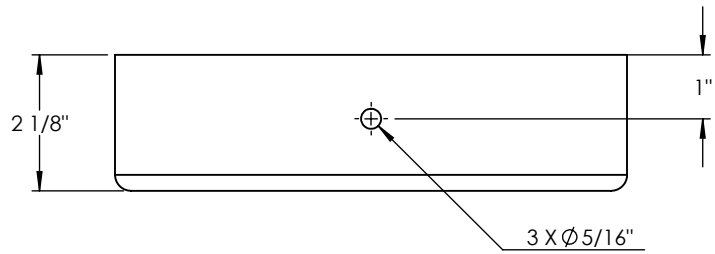

**PROPRIETARY AND CONFIDENTIAL**  
 THE INFORMATION CONTAINED IN THIS DRAWING IS THE SOLE PROPERTY OF <INSERT COMPANY NAME HERE>. ANY REPRODUCTION IN PART OR AS A WHOLE WITHOUT THE WRITTEN PERMISSION OF <INSERT COMPANY NAME HERE> IS PROHIBITED.

		UNLESS OTHERWISE SPECIFIED:		NAME	DATE
		DIMENSIONS ARE IN INCHES	DRAWN		
		TOLERANCES:	CHECKED		
		FRACTIONAL ±	ENG APPR.		
		ANGULAR: MACH ± BEND ±	MFG APPR.		
		TWO PLACE DECIMAL ±	Q.A.		
		THREE PLACE DECIMAL ±	COMMENTS:		
		INTERPRET GEOMETRIC TOLERANCING PER:			
		MATERIAL			
NEXT ASSY	USED ON	FINISH			
APPLICATION		DO NOT SCALE DRAWING			

SPUN ALUMINUM 0.125"

TITLE:

LH40LEDC-LV-BLK-99-ARM-DIM-40K

SIZE DWG. NO. REV

**A**

SCALE: 1:3 WEIGHT: SHEET 13 OF 14

ITEM NO.	PART NUMBER	DESCRIPTION	QTY.
1	HD-ARM1-12W-MBK-WF-10"-30K-SPUN CANOPY	SPUN ALUMINUM 0.125"	1

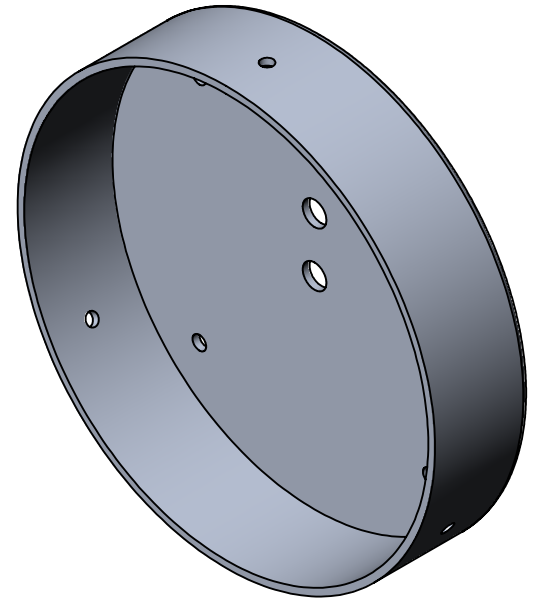
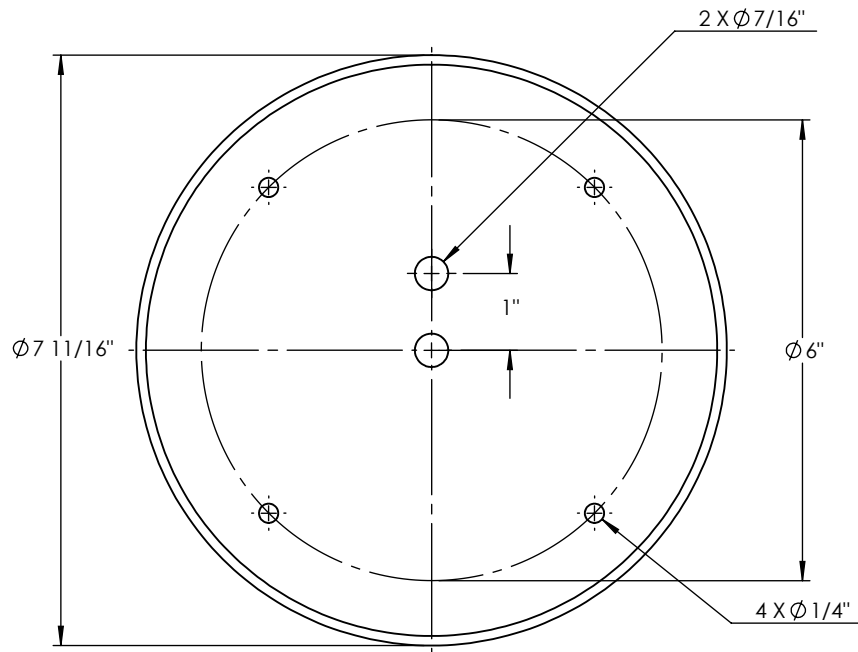
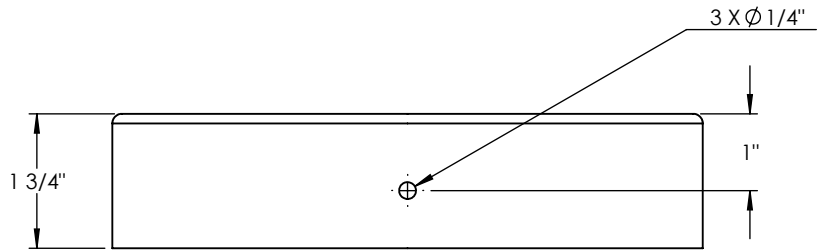

**PROPRIETARY AND CONFIDENTIAL**  
 THE INFORMATION CONTAINED IN THIS DRAWING IS THE SOLE PROPERTY OF <INSERT COMPANY NAME HERE>. ANY REPRODUCTION IN PART OR AS A WHOLE WITHOUT THE WRITTEN PERMISSION OF <INSERT COMPANY NAME HERE> IS PROHIBITED.

		UNLESS OTHERWISE SPECIFIED:		NAME	DATE	SPUN ALUMINUM 0.125"	
		DIMENSIONS ARE IN INCHES TOLERANCES: FRACTIONAL ± ANGULAR: MACH ± BEND ± TWO PLACE DECIMAL ± THREE PLACE DECIMAL ±	DRAWN			TITLE:	
		INTERPRET GEOMETRIC TOLERANCING PER:	CHECKED			LH40LEDC-LV-BLK-99-ARM-DIM-40K	
		MATERIAL	ENG APPR.			SIZE	DWG. NO.
		FINISH	MFG APPR.			<b>A</b>	REV
NEXT ASSY	USED ON		Q.A.			SCALE: 1:2.5 WEIGHT:	
APPLICATION		DO NOT SCALE DRAWING	COMMENTS:			SHEET 14 OF 14	