

ITEM NO.	PART NUMBER	DESCRIPTION	QTY.	CUT
1	BWL-MDCRS-39X9-50W-AB-WF-DIM-35K-SPUN CANOPY	SPUN ALUMINUM 0.080"	1	
2	BWL-MDCRS-39X9-50W-AB-WF-DIM-35K-SUPPORT FIREPLATE	SPUN ALUMINUM 0.080"	1	
3	BWL-MDCRS-39X9-50W-AB-WF-DIM-35K-PLATE ACCENT FIN	ALUMINUM 0.250" PLATE	1	
4	BWL-MDCRS-39X9-50W-AB-WF-DIM-35K-PLATE ACCENT FIN	ALUMINUM 0.250" PLATE	1	
5	BWL-MDCRS-39X9-50W-AB-WF-DIM-35K-SPUN DOOR BRACKET	SPUN ALUMINUM 0.080"	1	
6	BWL-MDCRS-39X9-50W-AB-WF-DIM-35K-ALUMINUM ROUND BAR	1/2" ROUND ALUMINUM BAR	1	
7	BWL-MDCRS-39X9-50W-AB-WF-DIM-35K-ROUND LED PLATE FLAT	ALUMINUM 0.0635"	1	
8	BWL-MDCRS-39X9-50W-AB-WF-DIM-35K-ACRYLIC BOWL	ACRYLIC	1	
9	90272A194	#8-32 SCREW	12	
10	91099A265	FLAT SCREW	4	
11	KTLD-25-UV-700-VDIM-LA1	DRIVER	3	
12	Airtailed PN105B-11-SS	LED	12	

UNLESS OTHERWISE SPECIFIED:

DIMENSIONS ARE IN INCHES
 TOLERANCES:
 FRACTIONAL ± .003
 ANGULAR: MACH ± .01 BEND ±
 TWO PLACE DECIMAL ±
 THREE PLACE DECIMAL ± .001

INTERPRET GEOMETRIC
 TOLERANCING PER:
 MATERIAL

FINISH

DRAWN

CHECKED

ENG APPR.

MFG APPR.

Q.A.

COMMENTS:

NAME DATE

TITLE:

BWL-MDCRS-39X9-50W-AB-WF-DIM-35K

SIZE DWG. NO.

REV

A TICKET 26981

SCALE: 1:20 WEIGHT:

SHEET 1 OF 12

ALL BEND RADIUS .030"

APPLICATION

DO NOT SCALE DRAWING



EVERGREEN LIGHTING

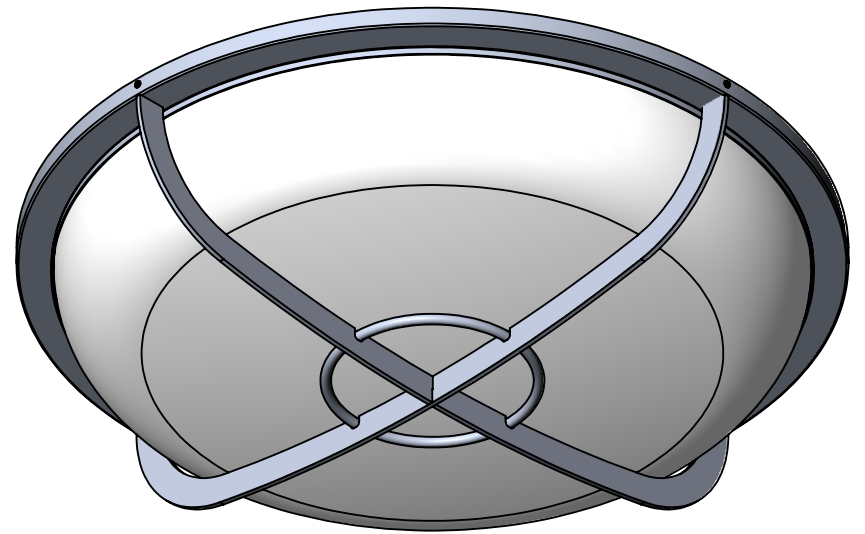
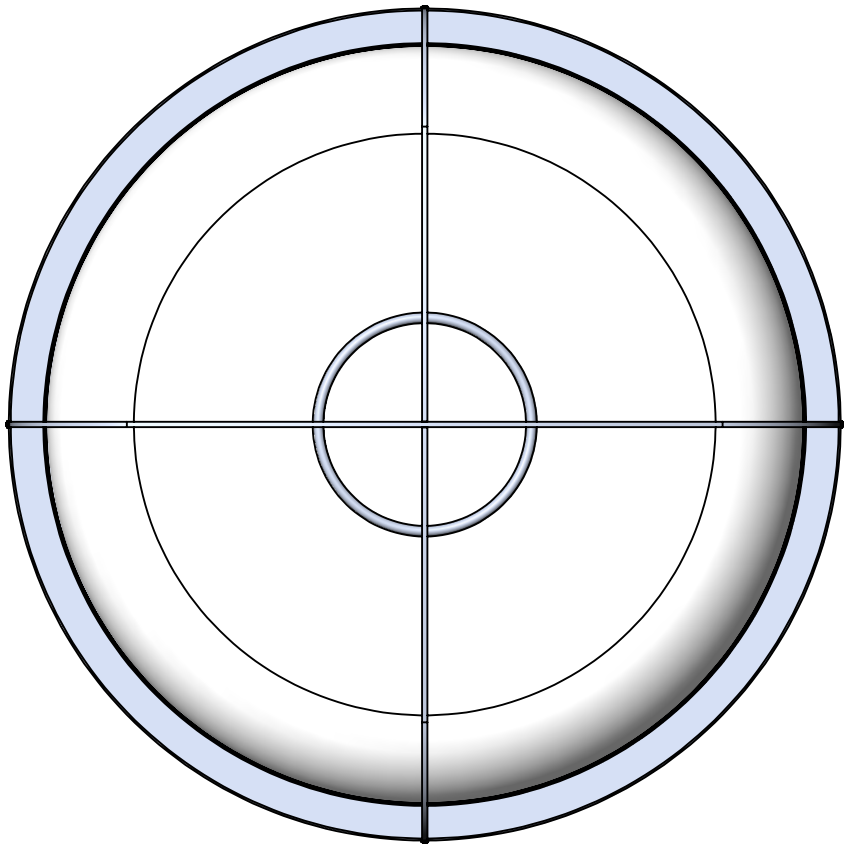
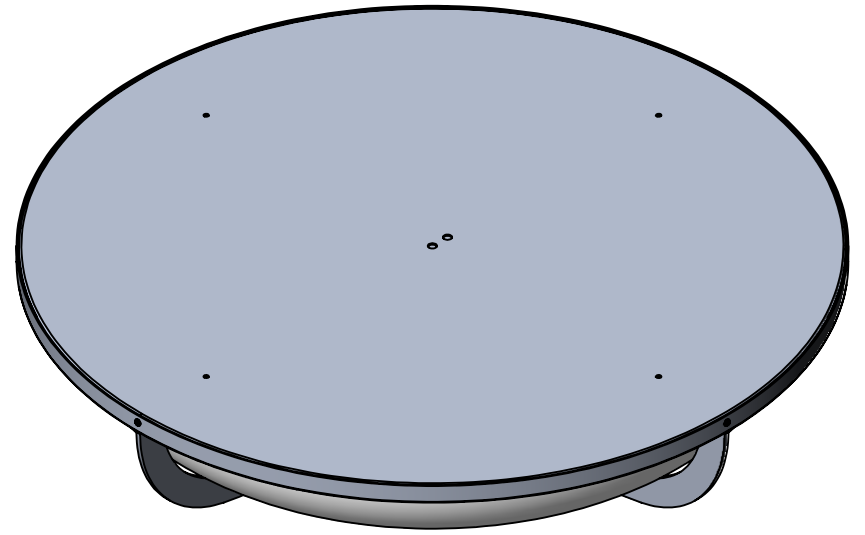
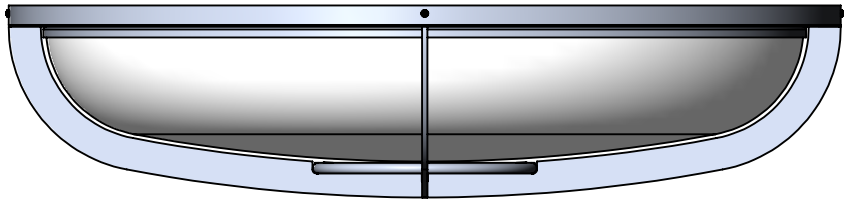

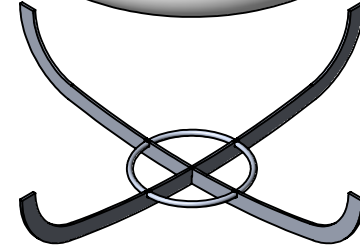
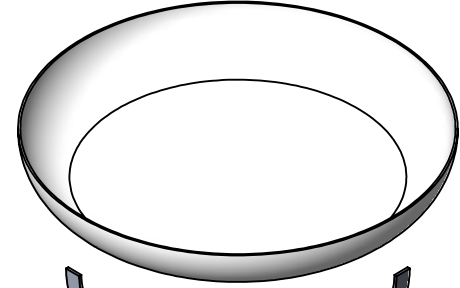
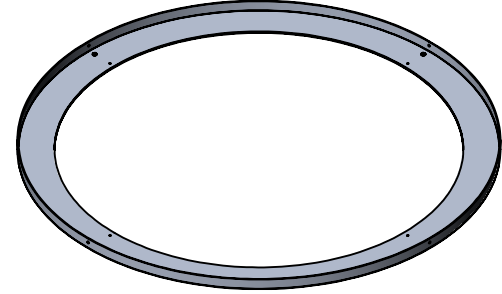
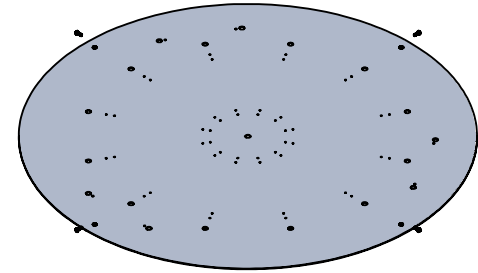
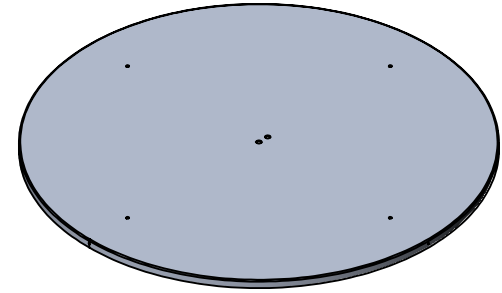
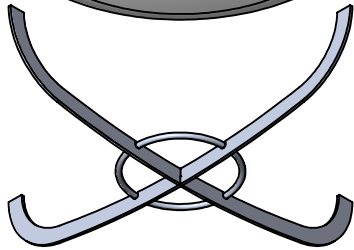
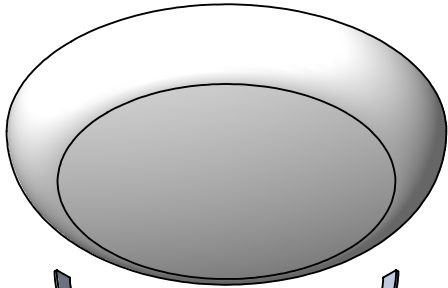
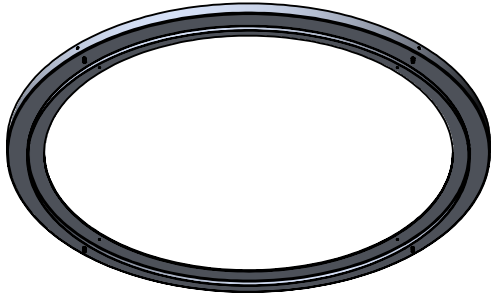
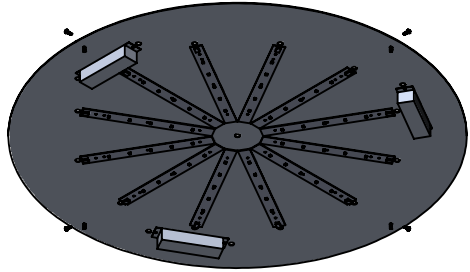
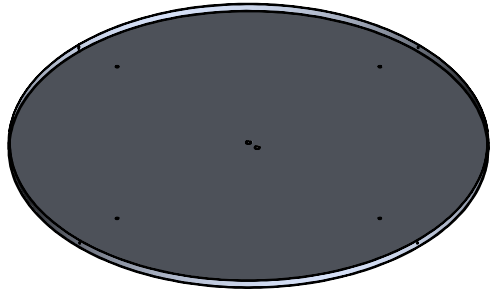

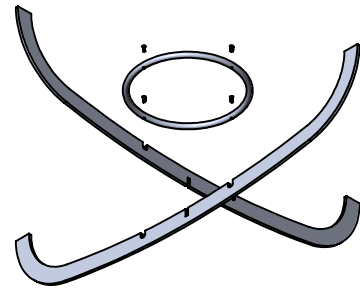
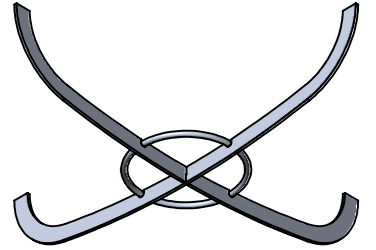
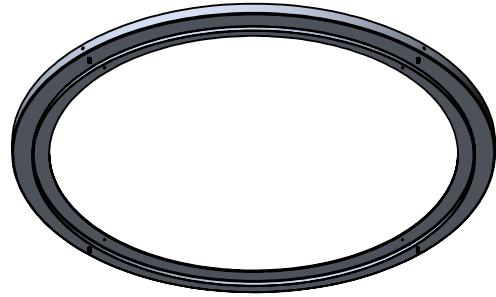
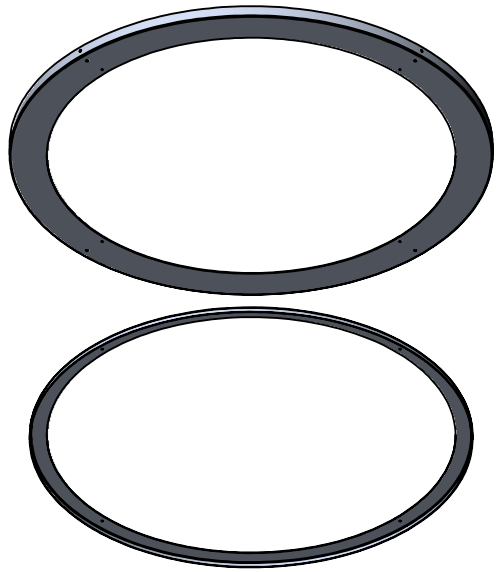

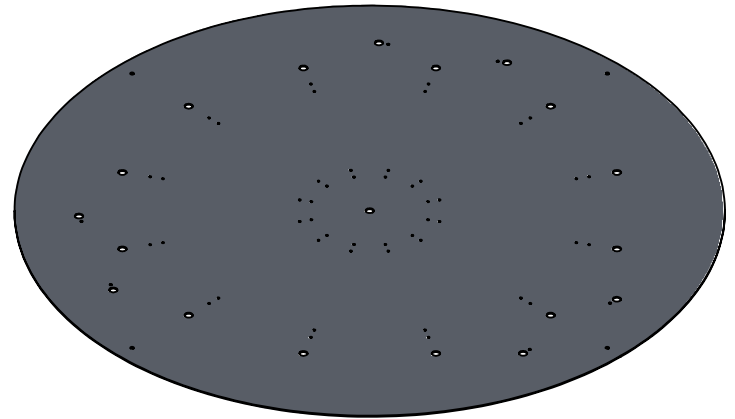
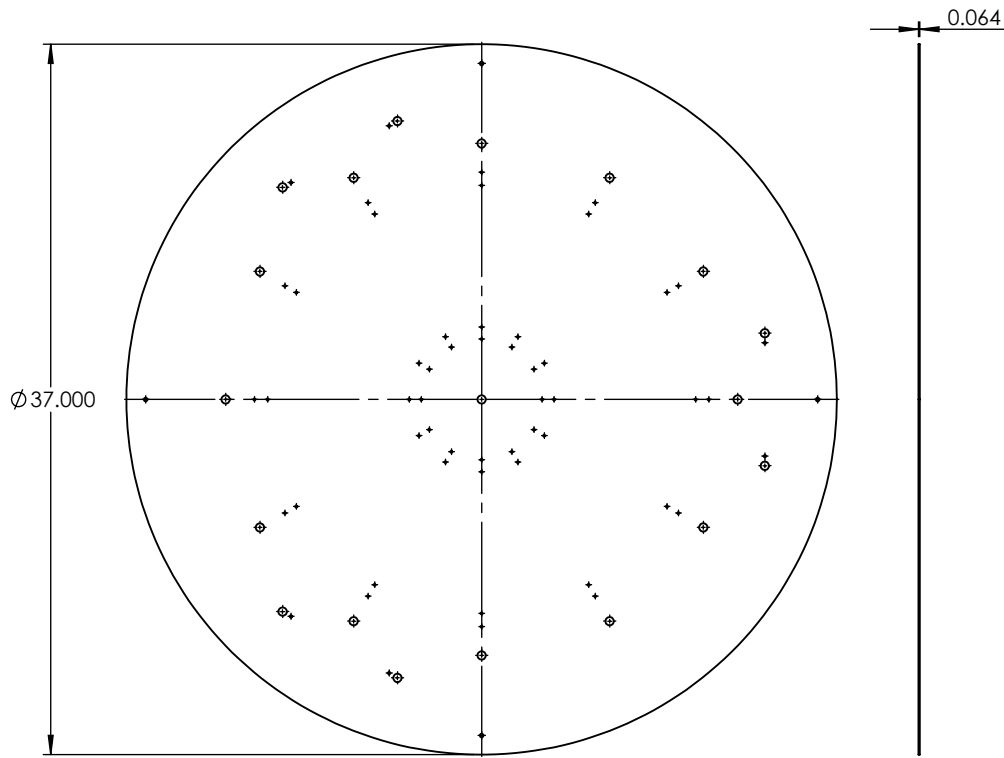

PROPRIETARY AND CONFIDENTIAL
 THE INFORMATION CONTAINED IN THIS DRAWING IS THE SOLE PROPERTY OF <INSERT COMPANY NAME HERE>. ANY REPRODUCTION IN PART OR AS A WHOLE WITHOUT THE WRITTEN PERMISSION OF <INSERT COMPANY NAME HERE> IS PROHIBITED.

		UNLESS OTHERWISE SPECIFIED:		NAME	DATE	ALUMINUM 0.0635"		
		DIMENSIONS ARE IN INCHES TOLERANCES: FRACTIONAL ± ANGULAR: MACH ± BEND ± TWO PLACE DECIMAL ± THREE PLACE DECIMAL ±	DRAWN					TITLE:
		INTERPRET GEOMETRIC TOLERANCING PER:	CHECKED			BWL-MDCRS-39X9-50W-AB-WF-DIM-35K		
		MATERIAL	ENG APPR.					
		FINISH	MFG APPR.			SIZE	DWG. NO.	REV
NEXT ASSY	USED ON		Q.A.			A		
APPLICATION		DO NOT SCALE DRAWING	COMMENTS:				SCALE: 1:10	WEIGHT:

5

4

3

2

1

ITEM NO.	PART NUMBER	DESCRIPTION	QTY.
1	BWL-MDCRS-39X9-50W-AB-WF-DIM-35K-SPUN CANOPY	SPUN ALUMINUM 0.080"	1

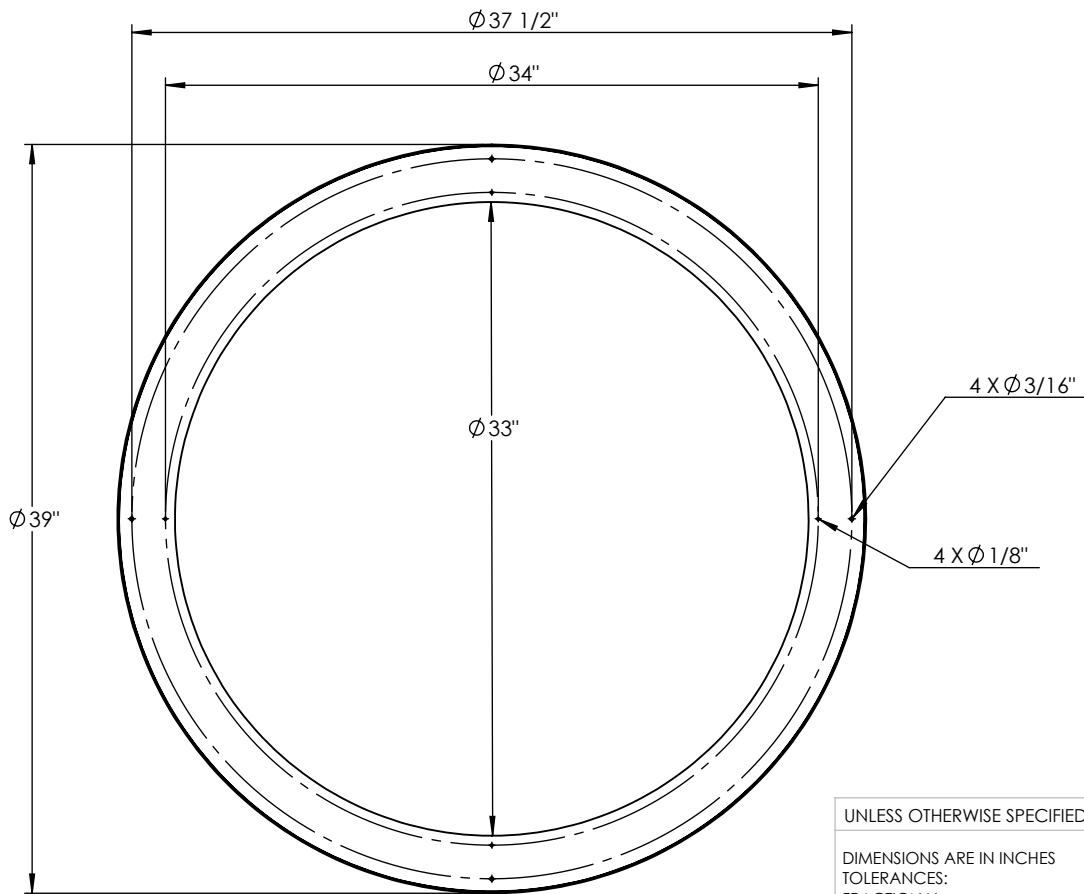
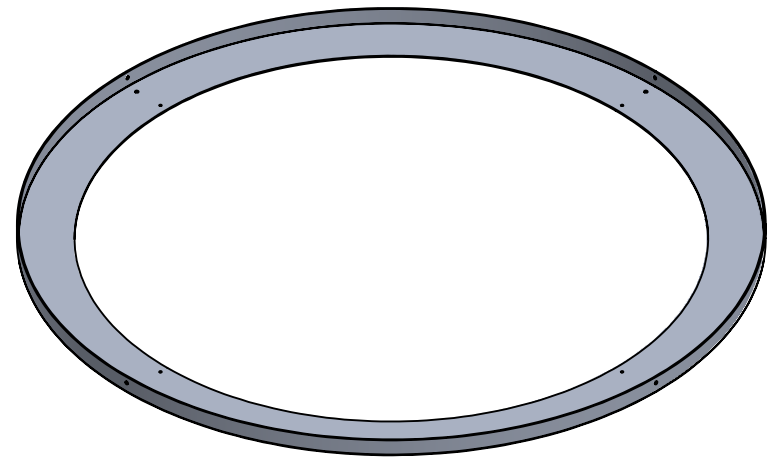
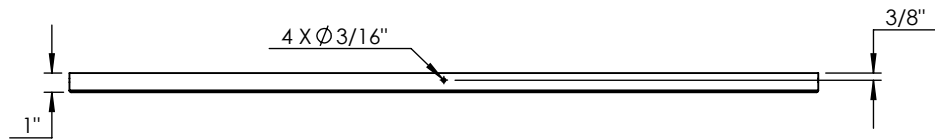

UNLESS OTHERWISE SPECIFIED:		NAME	DATE	SPUN ALUMINUM 0.080"	
DIMENSIONS ARE IN INCHES TOLERANCES: FRACTIONAL ± ANGULAR: MACH ± BEND ± TWO PLACE DECIMAL ± THREE PLACE DECIMAL ±		DRAWN		TITLE:	
		CHECKED		BWL-MDCRS-39X9-50W-AB-WF-DIM-35K	
		ENG APPR.		SIZE DWG. NO. REV	
		MFG APPR.		SCALE: 1:10 WEIGHT: SHEET 6 OF 12	
INTERPRET GEOMETRIC TOLERANCING PER:		Q.A.		COMMENTS:	
MATERIAL					
FINISH					

PROPRIETARY AND CONFIDENTIAL
THE INFORMATION CONTAINED IN THIS DRAWING IS THE SOLE PROPERTY OF <INSERT COMPANY NAME HERE>. ANY REPRODUCTION IN PART OR AS A WHOLE WITHOUT THE WRITTEN PERMISSION OF <INSERT COMPANY NAME HERE> IS PROHIBITED.

NEXT ASSY	USED ON
APPLICATION	

DO NOT SCALE DRAWING

ITEM NO.	PART NUMBER	DESCRIPTION	QTY.
1	BWL-MDCRS-39X9-50W-AB-WF-DIM-35K-SPUN CANOPY	SPUN ALUMINUM 0.080"	1

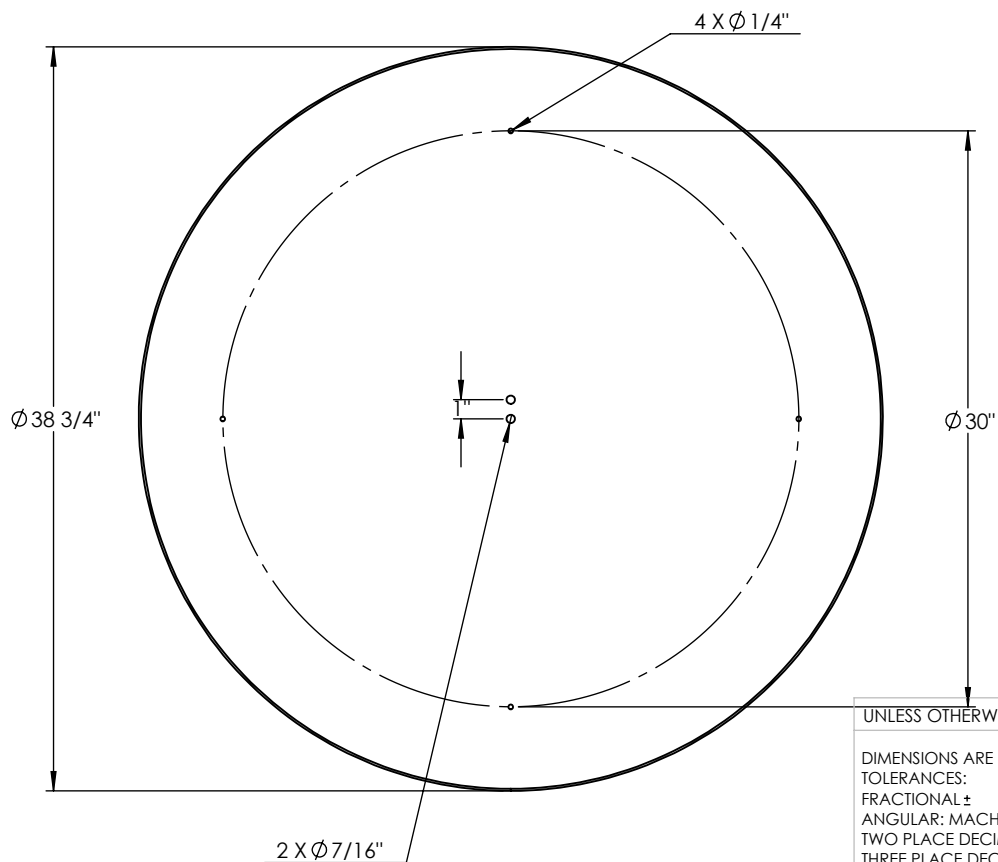
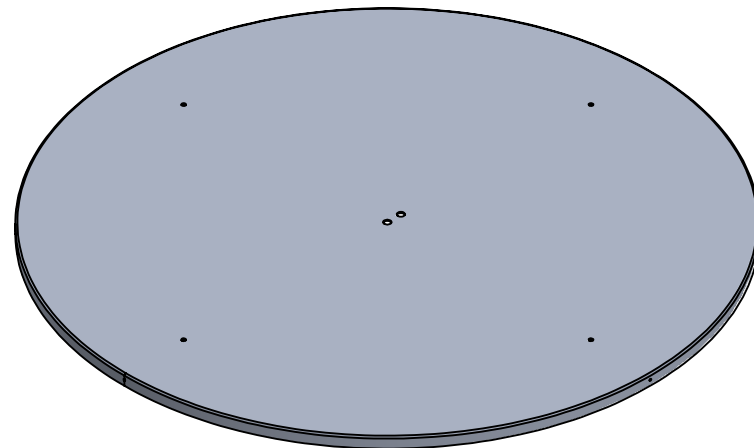
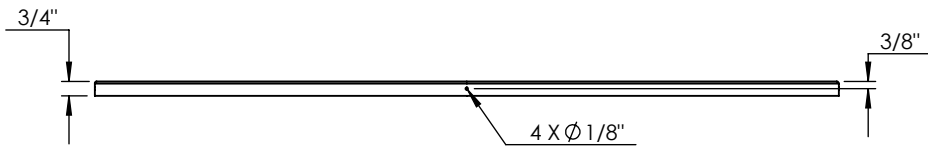

UNLESS OTHERWISE SPECIFIED:
 DIMENSIONS ARE IN INCHES
 TOLERANCES:
 FRACTIONAL ±
 ANGULAR: MACH ± BEND ±
 TWO PLACE DECIMAL ±
 THREE PLACE DECIMAL ±

INTERPRET GEOMETRIC TOLERANCING PER:
 MATERIAL
 FINISH
 APPLICATION
 DO NOT SCALE DRAWING

	NAME	DATE
DRAWN		
CHECKED		
ENG APPR.		
MFG APPR.		
Q.A.		

COMMENTS:

SPUN ALUMINUM 0.080"		
TITLE:		
BWL-MDCRS-39X9-50W-AB-WF-DIM-35K		
SIZE	DWG. NO.	REV
A		
SCALE: 1:10	WEIGHT:	SHEET 7 OF 12

PROPRIETARY AND CONFIDENTIAL
 THE INFORMATION CONTAINED IN THIS DRAWING IS THE SOLE PROPERTY OF <INSERT COMPANY NAME HERE>. ANY REPRODUCTION IN PART OR AS A WHOLE WITHOUT THE WRITTEN PERMISSION OF <INSERT COMPANY NAME HERE> IS PROHIBITED.

NEXT ASSY	USED ON
APPLICATION	DO NOT SCALE DRAWING

ITEM NO.	PART NUMBER	DESCRIPTION	QTY.
1	BWL-MDCRS-39X9-50W-AB-WF-DIM-35K-SPUN DOOR BRACKET	SPUN ALUMINUM 0.080"	1

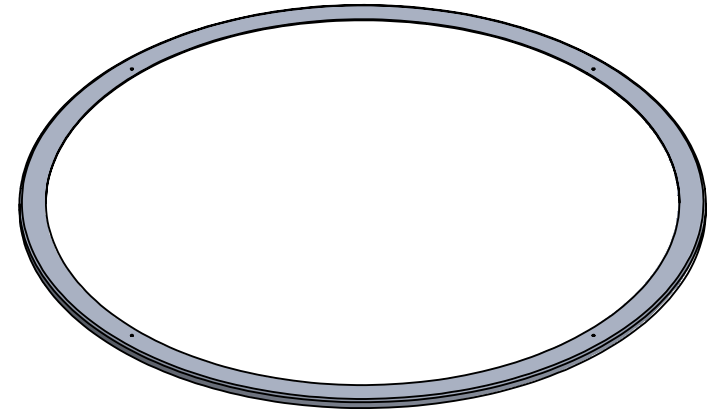
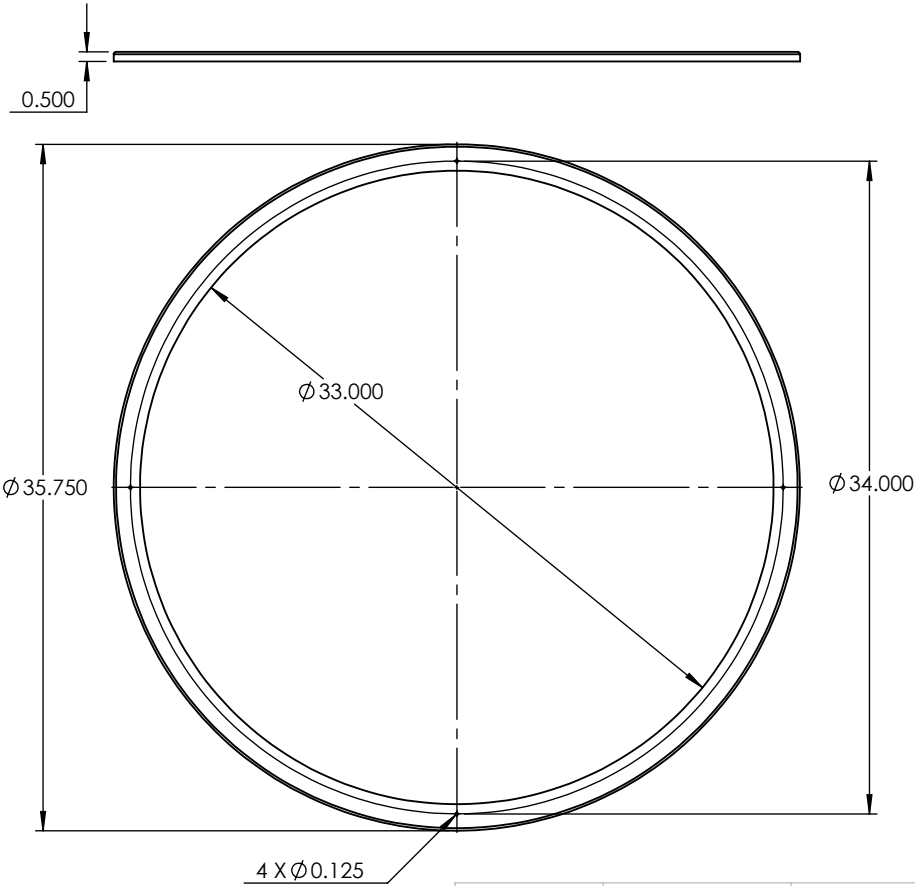

PROPRIETARY AND CONFIDENTIAL
 THE INFORMATION CONTAINED IN THIS DRAWING IS THE SOLE PROPERTY OF <INSERT COMPANY NAME HERE>. ANY REPRODUCTION IN PART OR AS A WHOLE WITHOUT THE WRITTEN PERMISSION OF <INSERT COMPANY NAME HERE> IS PROHIBITED.

		UNLESS OTHERWISE SPECIFIED:	NAME	DATE	SPUN ALUMINUM 0.080"	
		DIMENSIONS ARE IN INCHES	DRAWN		TITLE:	
		TOLERANCES:	CHECKED		BWL-MDCRS-39X9-50W-AB-WF-DIM-35K	
		FRACTIONAL \pm	ENG APPR.		SIZE DWG. NO. REV	
		ANGULAR: MACH \pm BEND \pm	MFG APPR.		A	
		TWO PLACE DECIMAL \pm	Q.A.		SCALE: 1:10 WEIGHT: SHEET 8 OF 12	
		THREE PLACE DECIMAL \pm	COMMENTS:			
		INTERPRET GEOMETRIC TOLERANCING PER:				
		MATERIAL				
NEXT ASSY	USED ON	FINISH				
APPLICATION		DO NOT SCALE DRAWING				

5

4

3

2

1

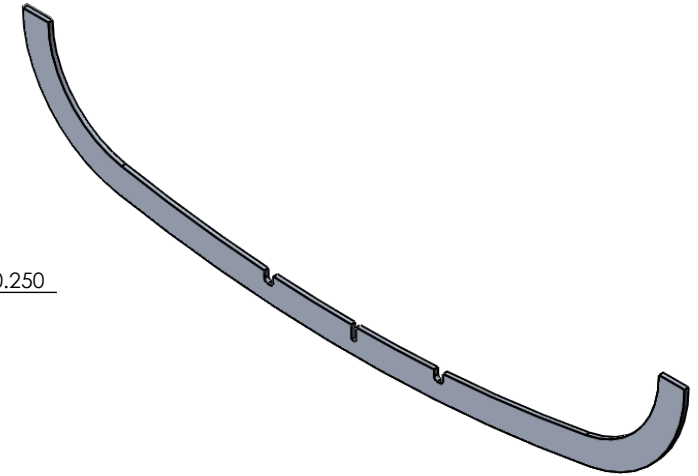
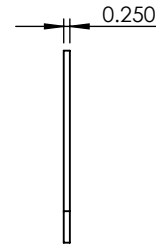
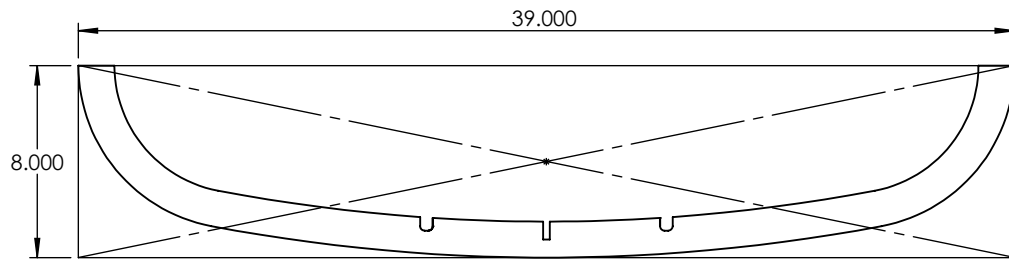
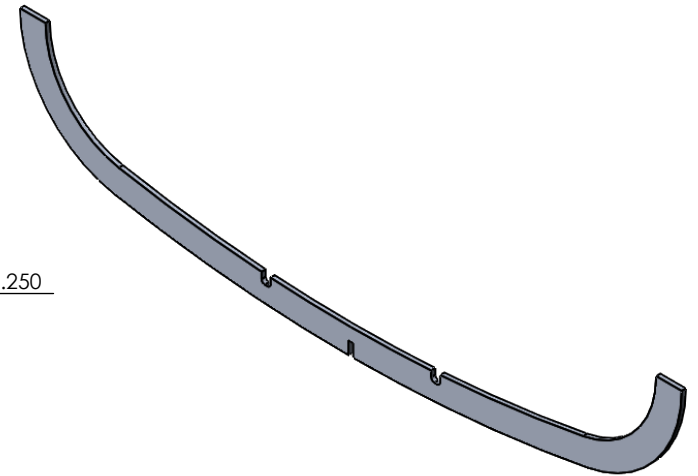
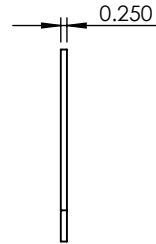
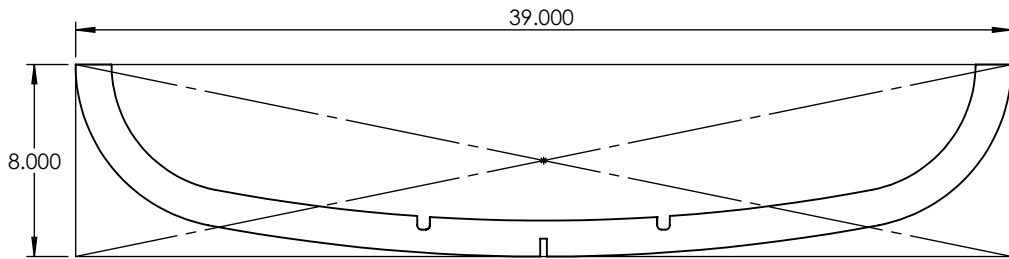

PROPRIETARY AND CONFIDENTIAL
 THE INFORMATION CONTAINED IN THIS DRAWING IS THE SOLE PROPERTY OF <INSERT COMPANY NAME HERE>. ANY REPRODUCTION IN PART OR AS A WHOLE WITHOUT THE WRITTEN PERMISSION OF <INSERT COMPANY NAME HERE> IS PROHIBITED.

		UNLESS OTHERWISE SPECIFIED:		NAME	DATE
		DIMENSIONS ARE IN INCHES	DRAWN		
		TOLERANCES:	CHECKED		
		FRACTIONAL ±	ENG APPR.		
		ANGULAR: MACH ± BEND ±	MFG APPR.		
		TWO PLACE DECIMAL ±	Q.A.		
		THREE PLACE DECIMAL ±	COMMENTS:		
		INTERPRET GEOMETRIC TOLERANCING PER:			
		MATERIAL			
NEXT ASSY	USED ON	FINISH			
APPLICATION		DO NOT SCALE DRAWING			

ALUMINUM 0.250" PLATE

TITLE:
 BWL-MDCRS-39X9-50W-AB-WF-DIM-35K

SIZE	DWG. NO.	REV
A		
SCALE: 1:8	WEIGHT:	SHEET 9 OF 12

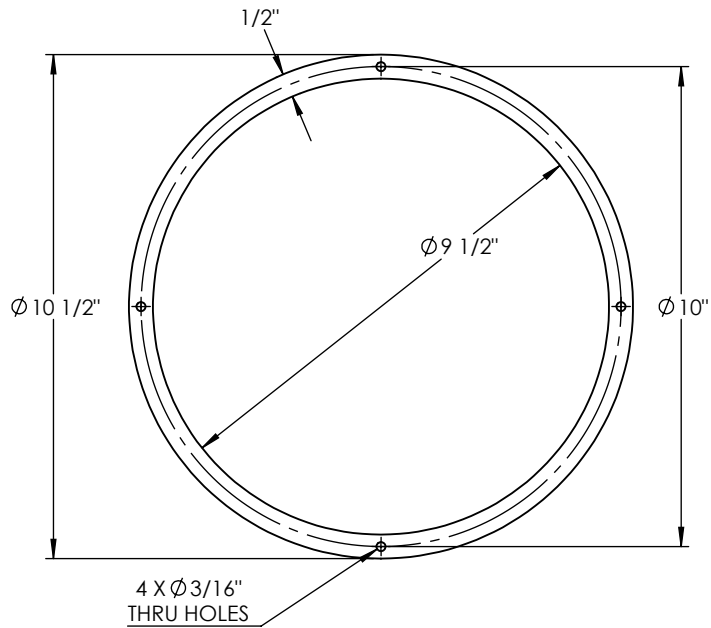
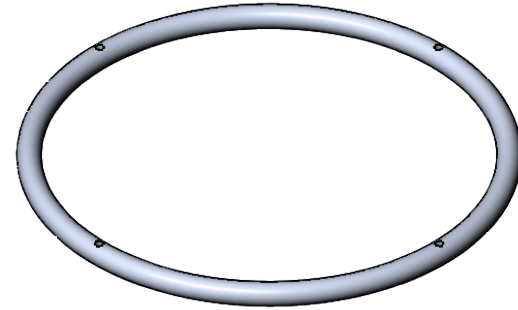
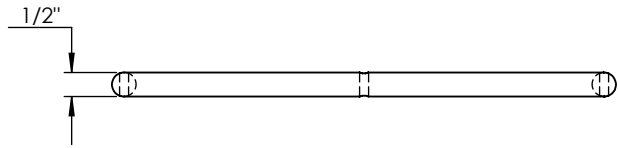

PROPRIETARY AND CONFIDENTIAL
 THE INFORMATION CONTAINED IN THIS DRAWING IS THE SOLE PROPERTY OF <INSERT COMPANY NAME HERE>. ANY REPRODUCTION IN PART OR AS A WHOLE WITHOUT THE WRITTEN PERMISSION OF <INSERT COMPANY NAME HERE> IS PROHIBITED.

		UNLESS OTHERWISE SPECIFIED:	NAME	DATE
		DIMENSIONS ARE IN INCHES	DRAWN	
		TOLERANCES:	CHECKED	
		FRACTIONAL \pm	ENG APPR.	
		ANGULAR: MACH \pm BEND \pm	MFG APPR.	
		TWO PLACE DECIMAL \pm	Q.A.	
		THREE PLACE DECIMAL \pm	COMMENTS:	
		INTERPRET GEOMETRIC TOLERANCING PER:		
		MATERIAL		
NEXT ASSY	USED ON	FINISH		
APPLICATION		DO NOT SCALE DRAWING		

1/2" ROUND ALUMINUM BAR		
TITLE:		
BWL-MDCRS-39X9-50W-AB-WF-DIM-35K		
SIZE	DWG. NO.	REV
A		
SCALE: 1:4	WEIGHT:	SHEET 10 OF 12

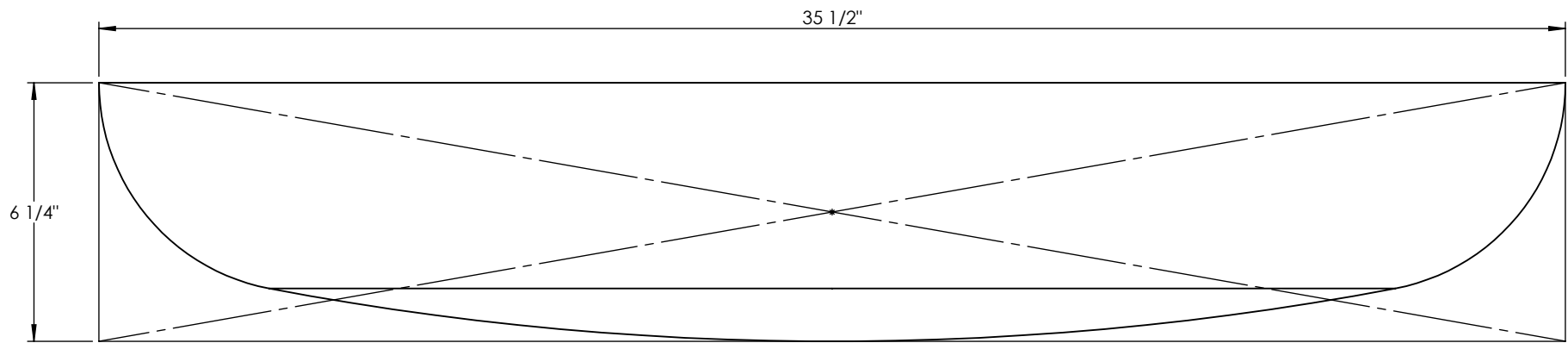

PROPRIETARY AND CONFIDENTIAL
 THE INFORMATION CONTAINED IN THIS DRAWING IS THE SOLE PROPERTY OF <INSERT COMPANY NAME HERE>. ANY REPRODUCTION IN PART OR AS A WHOLE WITHOUT THE WRITTEN PERMISSION OF <INSERT COMPANY NAME HERE> IS PROHIBITED.

		UNLESS OTHERWISE SPECIFIED:		NAME	DATE
		DIMENSIONS ARE IN INCHES	DRAWN		
		TOLERANCES:	CHECKED		
		FRACTIONAL ±	ENG APPR.		
		ANGULAR: MACH ± BEND ±	MFG APPR.		
		TWO PLACE DECIMAL ±	Q.A.		
		THREE PLACE DECIMAL ±	COMMENTS:		
		INTERPRET GEOMETRIC TOLERANCING PER:			
		MATERIAL			
		FINISH			
NEXT ASSY	USED ON				
APPLICATION		DO NOT SCALE DRAWING			

ACRYLIC		
TITLE:		
BWL-MDCRS-39X9-50W-AB-WF-DIM-35K		
SIZE	DWG. NO.	REV
A		
SCALE: 1:4	WEIGHT:	SHEET 11 OF 12

5

4

3

2

1

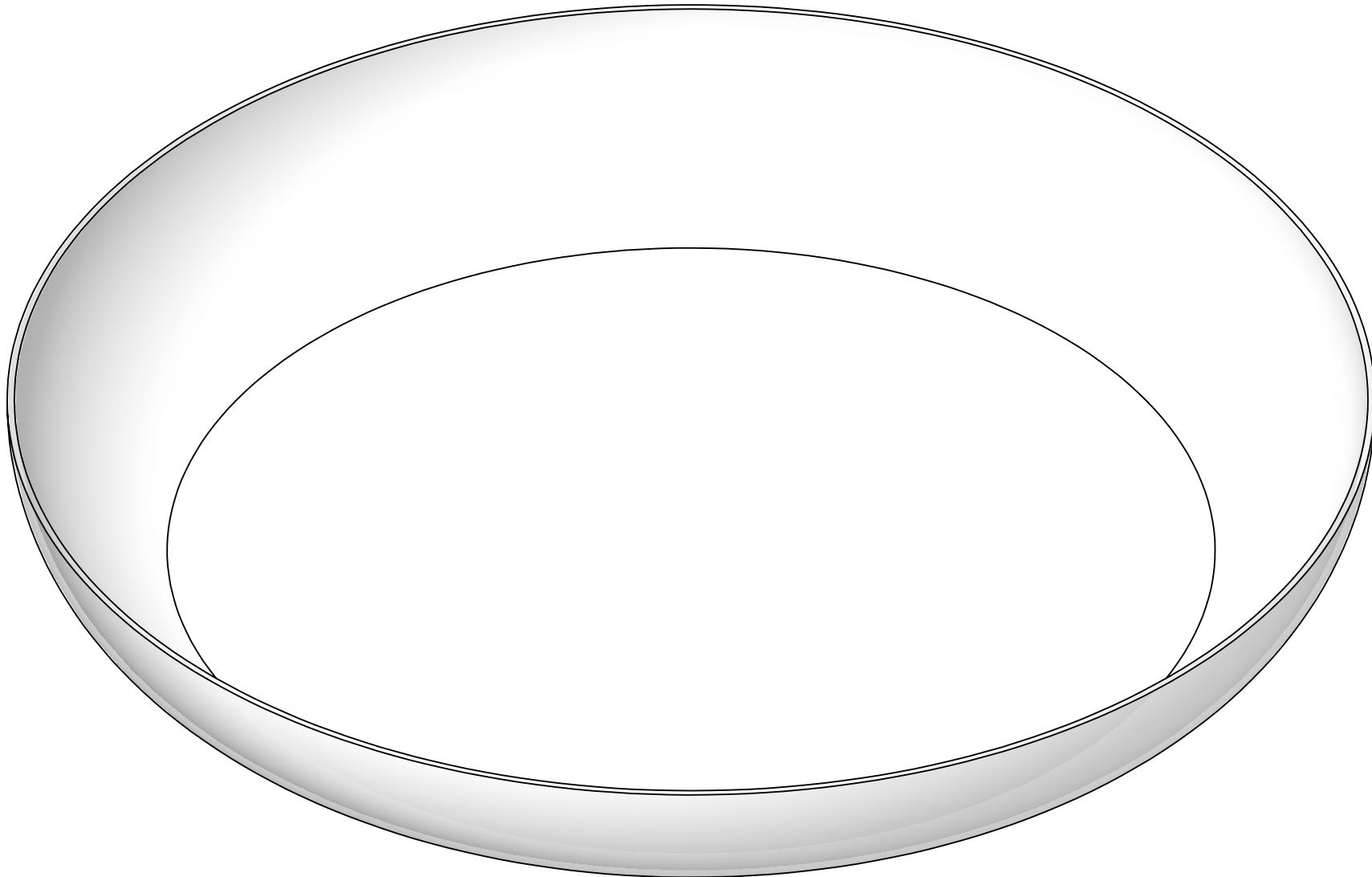

PROPRIETARY AND CONFIDENTIAL
 THE INFORMATION CONTAINED IN THIS DRAWING IS THE SOLE PROPERTY OF <INSERT COMPANY NAME HERE>. ANY REPRODUCTION IN PART OR AS A WHOLE WITHOUT THE WRITTEN PERMISSION OF <INSERT COMPANY NAME HERE> IS PROHIBITED.

		UNLESS OTHERWISE SPECIFIED:		NAME	DATE	ACRYLIC		
		DIMENSIONS ARE IN INCHES				TITLE:		
		TOLERANCES:				BWL-MDCRS-39X9-50W-AB-WF-DIM-35K		
		FRACTIONAL ±		DRAWN				
		ANGULAR: MACH ± BEND ±		CHECKED				
		TWO PLACE DECIMAL ±		ENG APPR.				
		THREE PLACE DECIMAL ±		MFG APPR.				
		INTERPRET GEOMETRIC TOLERANCING PER:		Q.A.				
		MATERIAL		COMMENTS:				
		FINISH				SIZE	DWG. NO.	REV
NEXT ASSY	USED ON					A		
APPLICATION		DO NOT SCALE DRAWING				SCALE: 1:4	WEIGHT:	SHEET 12 OF 12

5

4

3

2

1