

ITEM NO.	PART NUMBER	DESCRIPTION	QTY.	CUT
1	STP-REC-LV9-14X7-6W-MG-CFA-40K-FRAME PLATE	ALUMINUM 0.0635"	1	
2	STP-REC-LV9-14X7-6W-MG-CFA-40K-RECESSED BOX	22 GAUGE	1	
3	STP-REC-LV9-14X7-6W-MG-CFA-40K-PLATE	22 GAUGE	1	
4	STP-REC-LV9-14X7-6W-MG-CFA-40K-LED PLATE BRACKET	22 GAUGE	2	
5	STP-REC-LV9-14X7-6W-MG-CFA-40K-LED PLATE	22 GAUGE	1	
6	STP-REC-LV9-14X7-6W-MG-CFA-40K-BOX TAB	22 GAUGE	4	
7	STP-REC-LV9-14X7-6W-MG-CFA-40K-ACRYLIC	ACRYLIC	1	
8	Espen VEL19070MVH-1	DRIVER	1	
10	AltaILED_PN1010_RevD	LED	2	

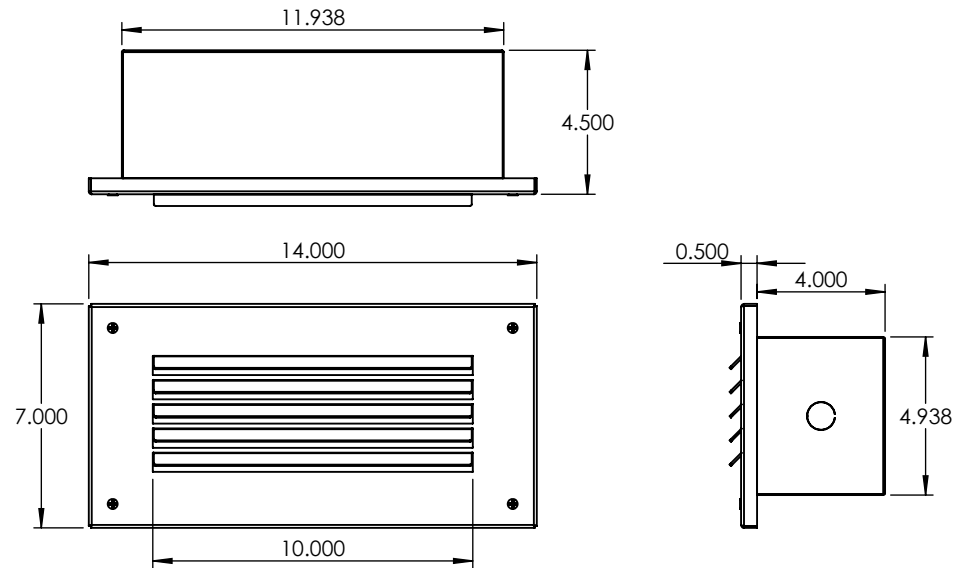
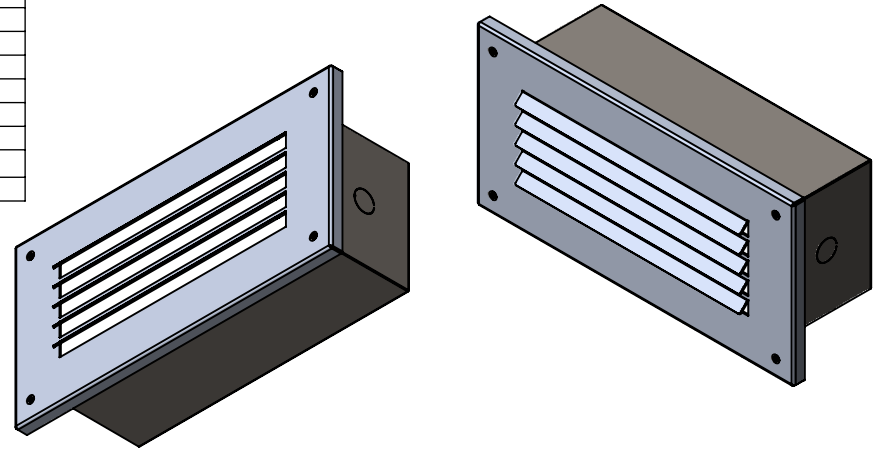
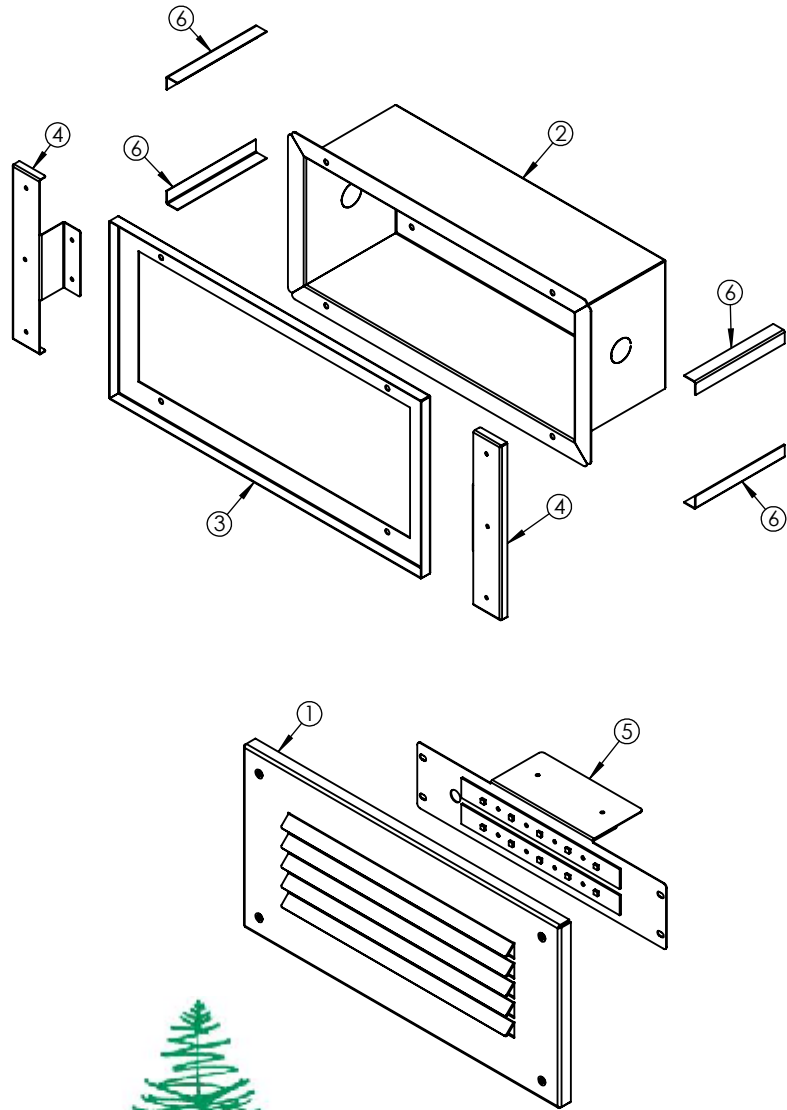

UNLESS OTHERWISE SPECIFIED:

DIMENSIONS ARE IN INCHES
TOLERANCES:
FRACTIONAL ± .003
ANGULAR: MACH ± .01 BEND ±
TWO PLACE DECIMAL ±
THREE PLACE DECIMAL ±.001

INTERPRET GEOMETRIC
TOLERANCING PER:

MATERIAL

FINISH

	NAME	DATE
DRAWN		
CHECKED		
ENG APPR.		
MFG APPR.		
Q.A.		
COMMENTS:		

TITLE:

STP-REC-LV9-14X7-6W-MG-CFA-40K

SIZE	DWG. NO.	REV
A	TICKET 26982	

SCALE: 1:6	WEIGHT:	SHEET 1 OF 8
------------	---------	--------------



ALL BEND RADIUS .030"

APPLICATION

DO NOT SCALE DRAWING

5

4

3

2

1

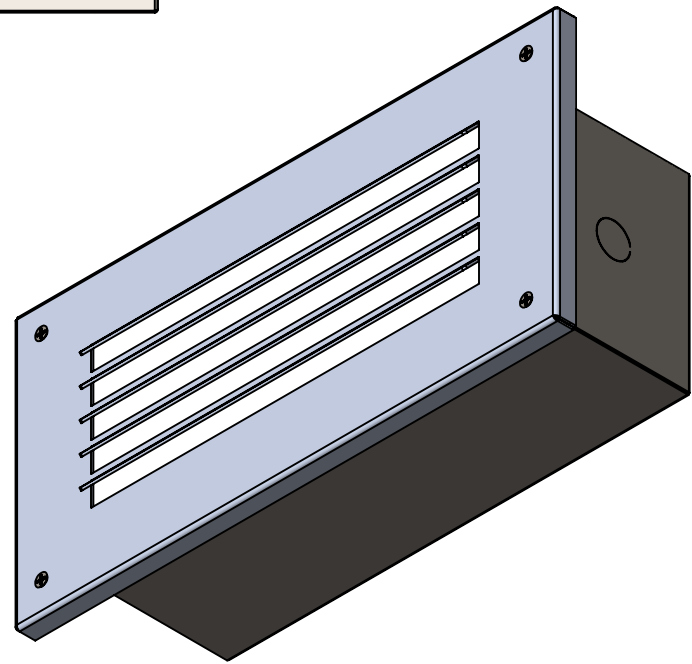
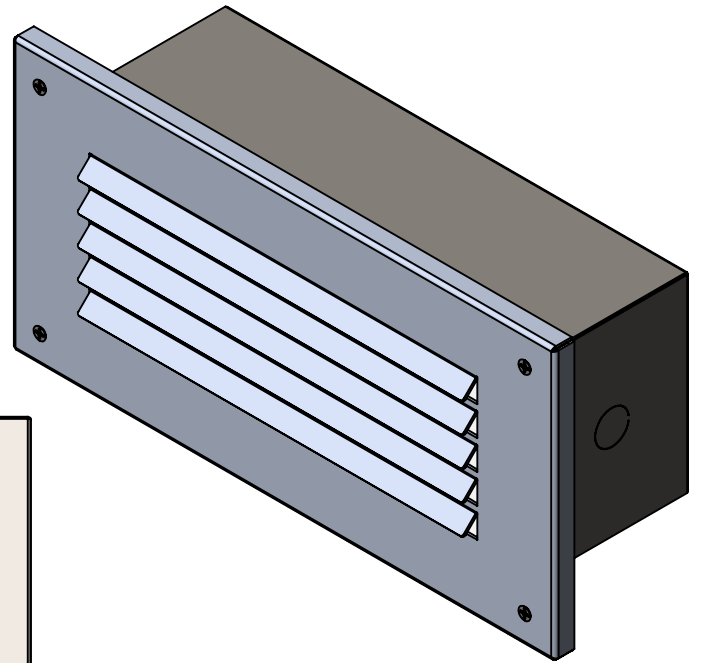
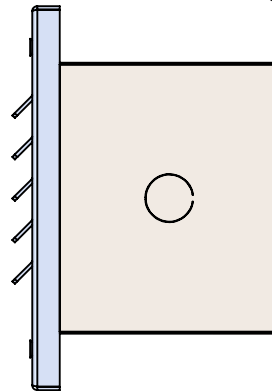
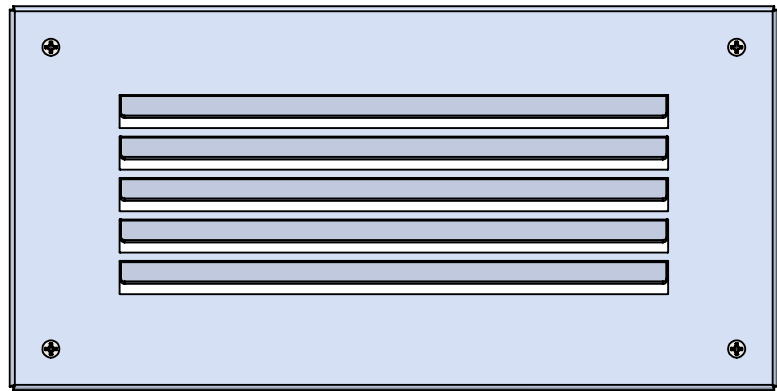

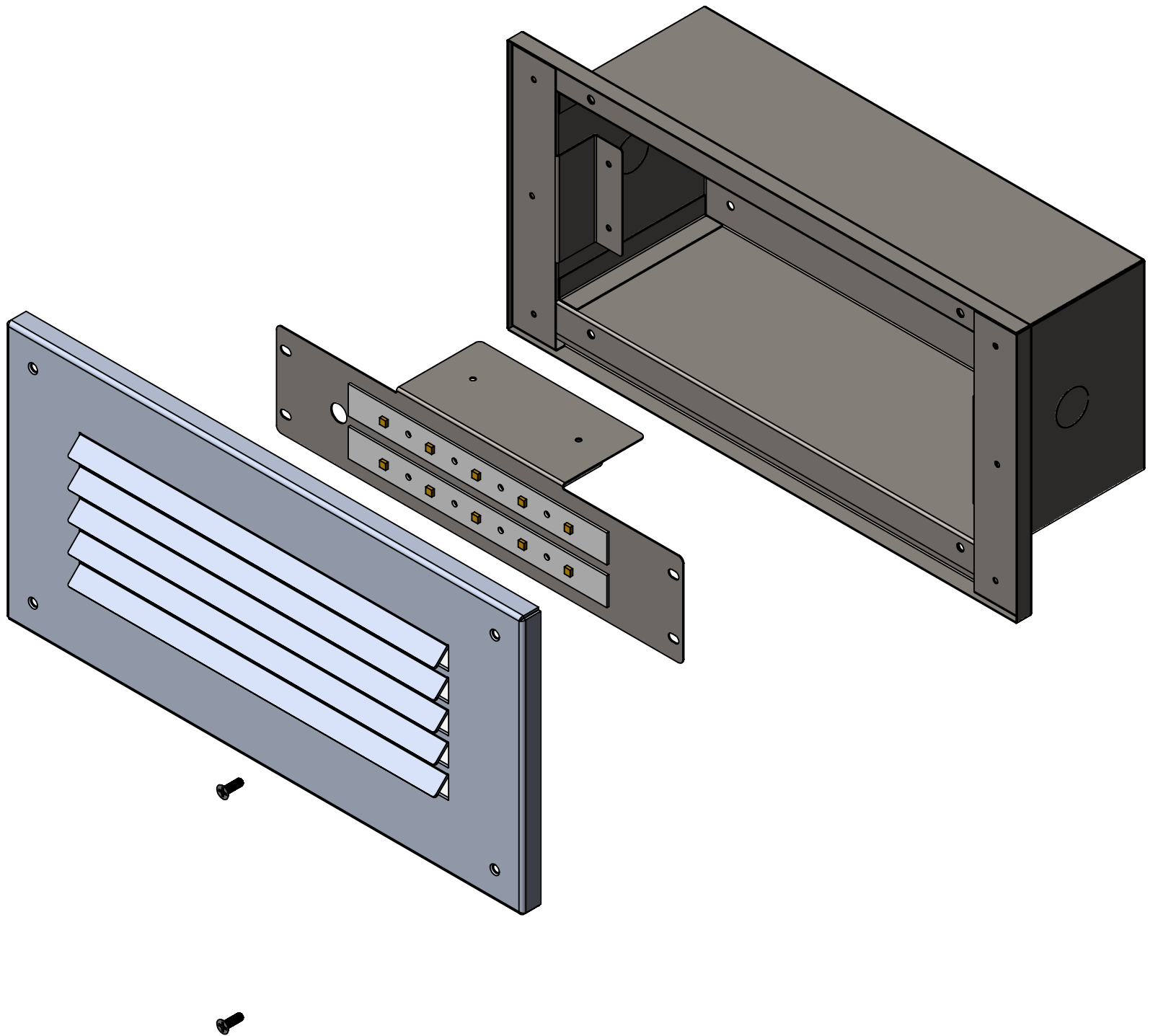

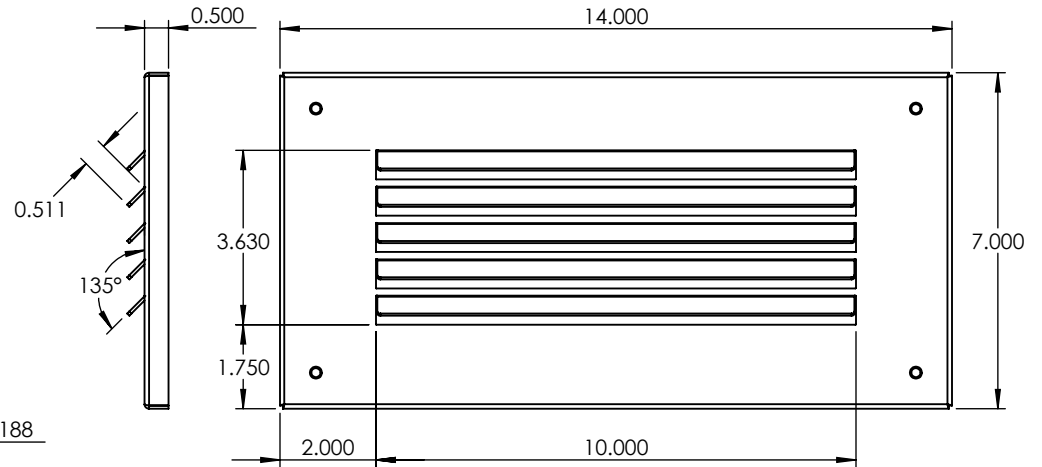
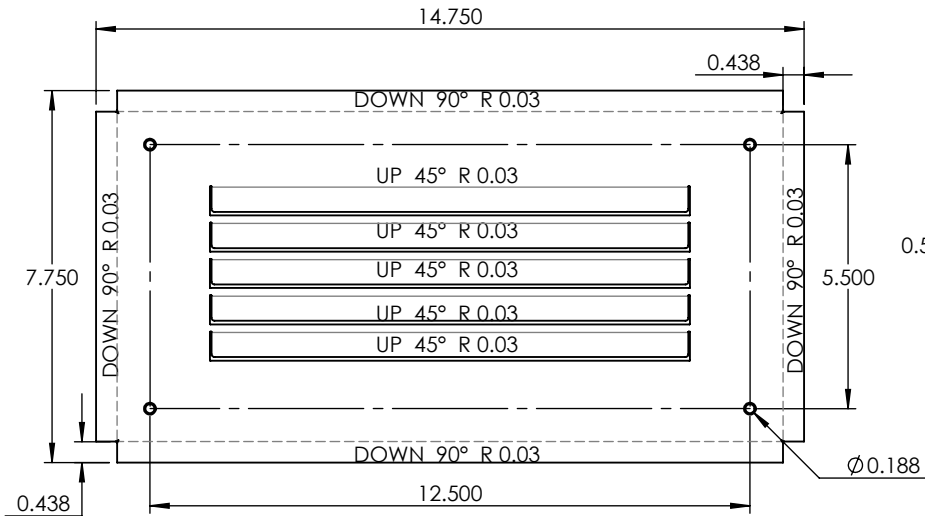
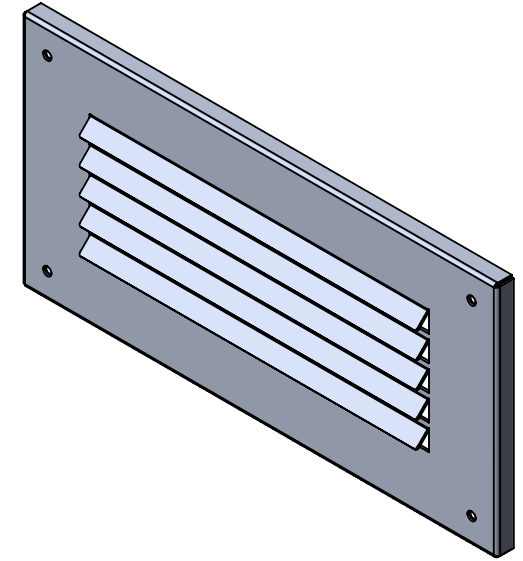

PROPRIETARY AND CONFIDENTIAL
 THE INFORMATION CONTAINED IN THIS DRAWING IS THE SOLE PROPERTY OF <INSERT COMPANY NAME HERE>. ANY REPRODUCTION IN PART OR AS A WHOLE WITHOUT THE WRITTEN PERMISSION OF <INSERT COMPANY NAME HERE> IS PROHIBITED.

		UNLESS OTHERWISE SPECIFIED:		NAME	DATE	ALUMINUM 0.0635"	
		DIMENSIONS ARE IN INCHES TOLERANCES: FRACTIONAL ± ANGULAR: MACH ± BEND ± TWO PLACE DECIMAL ± THREE PLACE DECIMAL ±		DRAWN		TITLE:	
		INTERPRET GEOMETRIC TOLERANCING PER:		CHECKED		STP-REC-LV9-14X7-6W-MG-CFA-40K	
		MATERIAL		ENG APPR.		SIZE DWG. NO. REV	
NEXT ASSY	USED ON	FINISH		MFG APPR.		A	
APPLICATION		DO NOT SCALE DRAWING		Q.A.		SCALE: 1:4 WEIGHT: SHEET 4 OF 8	
				COMMENTS:			

5

4

3

2

1

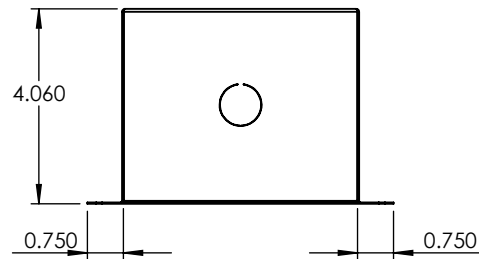
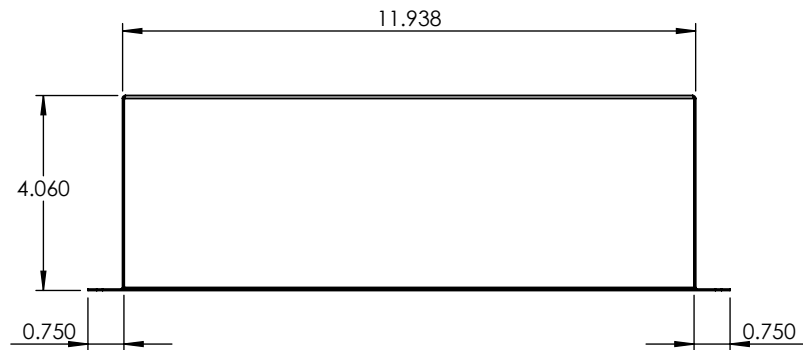
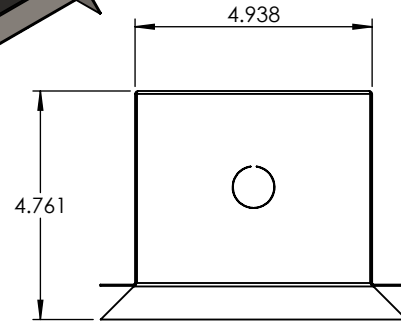
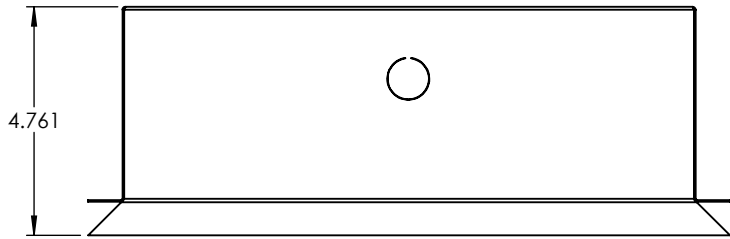
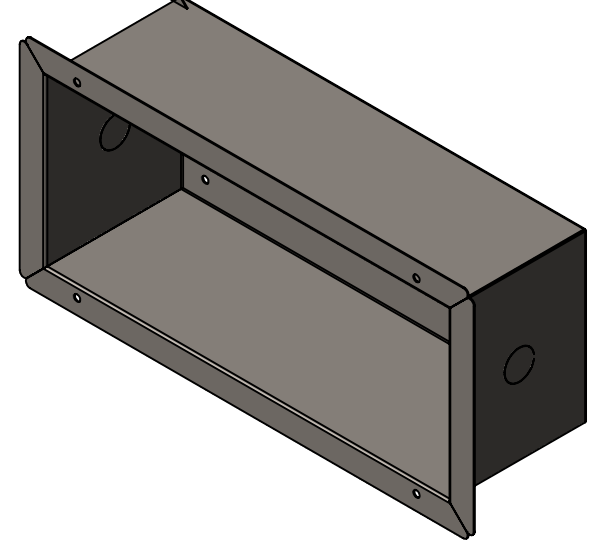
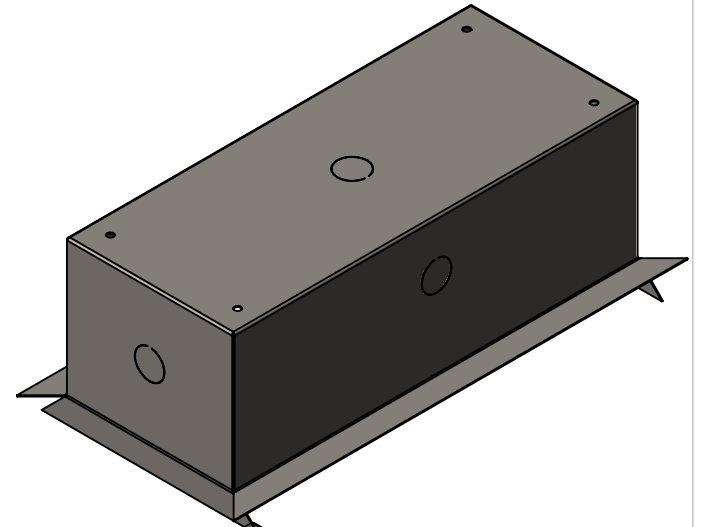
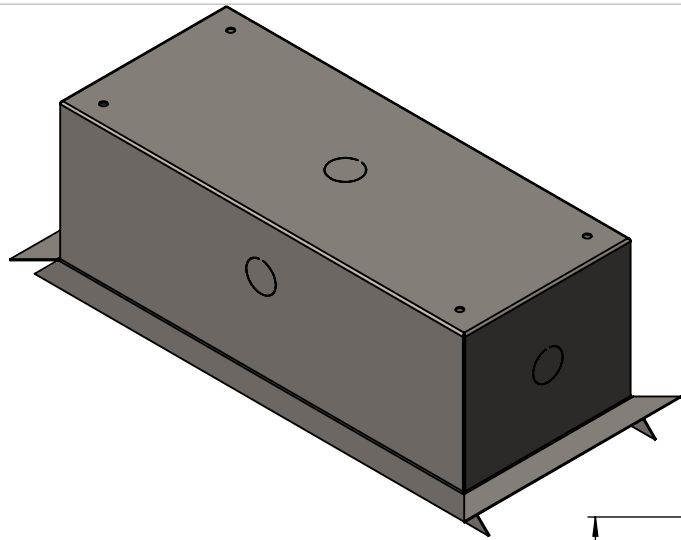

UNLESS OTHERWISE SPECIFIED:

DIMENSIONS ARE IN INCHES
 TOLERANCES:
 FRACTIONAL ±
 ANGULAR: MACH ± BEND ±
 TWO PLACE DECIMAL ±
 THREE PLACE DECIMAL ±

INTERPRET GEOMETRIC
 TOLERANCING PER:

MATERIAL

FINISH

DO NOT SCALE DRAWING

NAME	DATE

DRAWN	
CHECKED	
ENG APPR.	
MFG APPR.	

Q.A.
 COMMENTS:

22 GAUGE

TITLE:

STP-REC-LV9-14X7-6W-MG-CFA-40K

SIZE	DWG. NO.	REV
A		

SCALE: 1:4	WEIGHT:	SHEET 5 OF 8

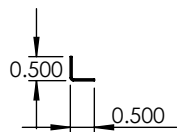
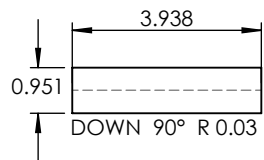
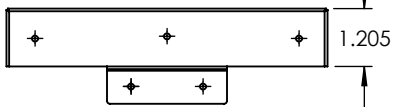
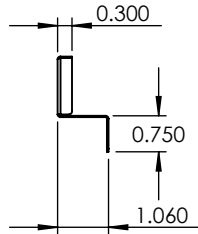
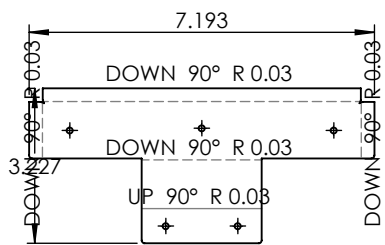
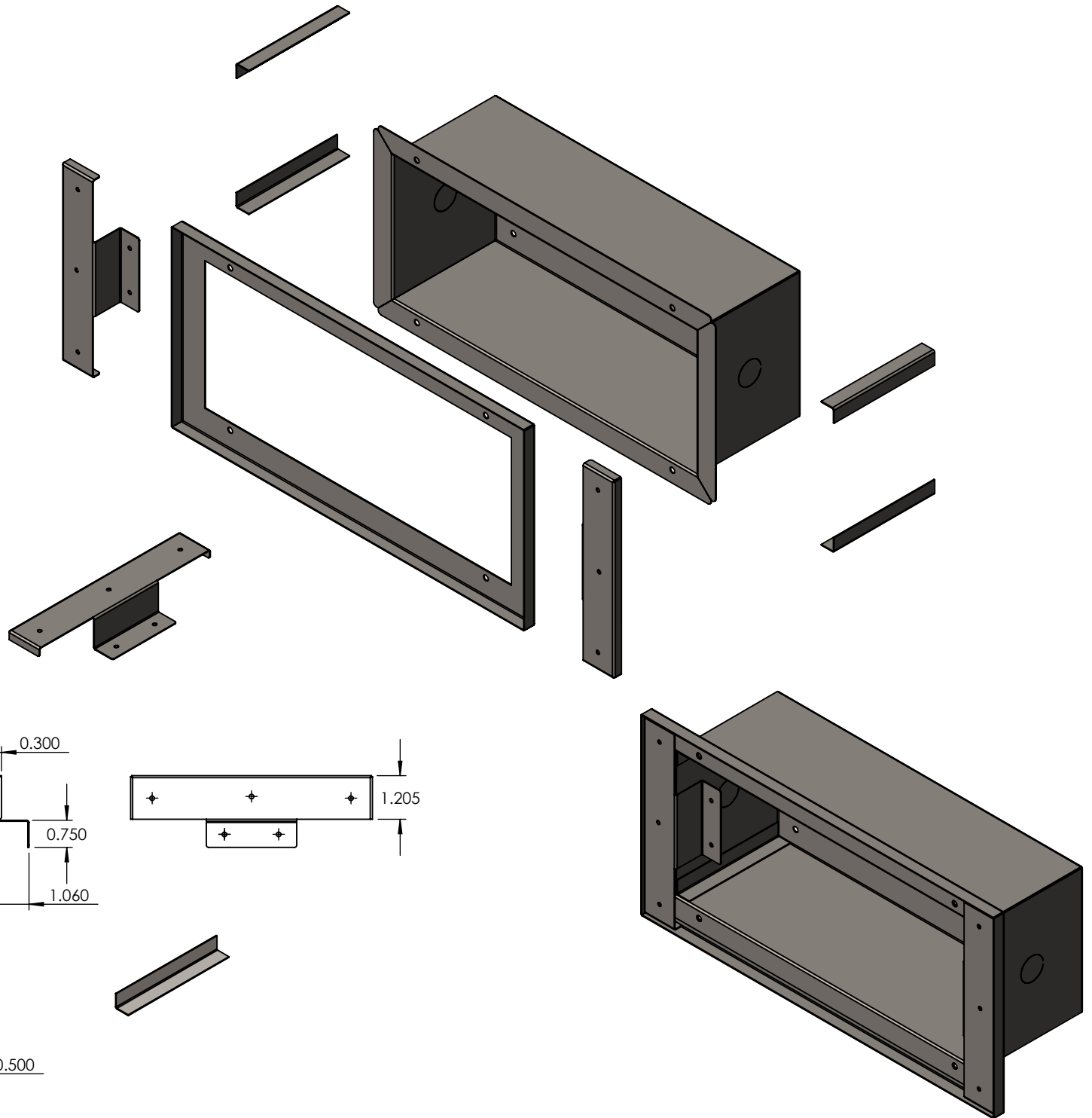

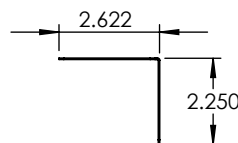
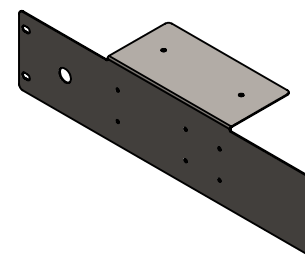
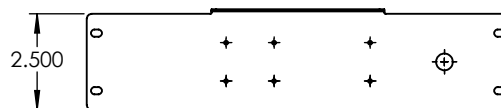
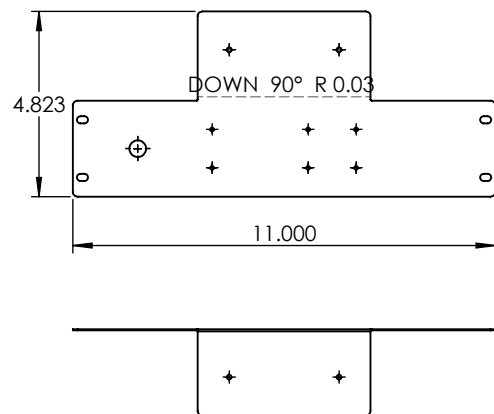
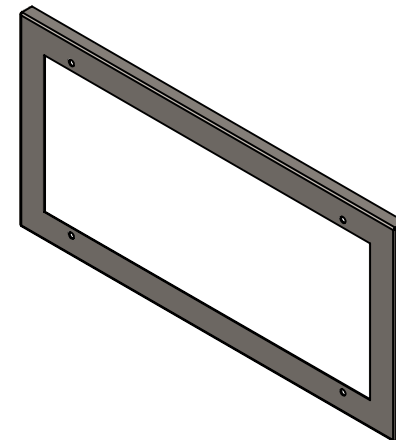
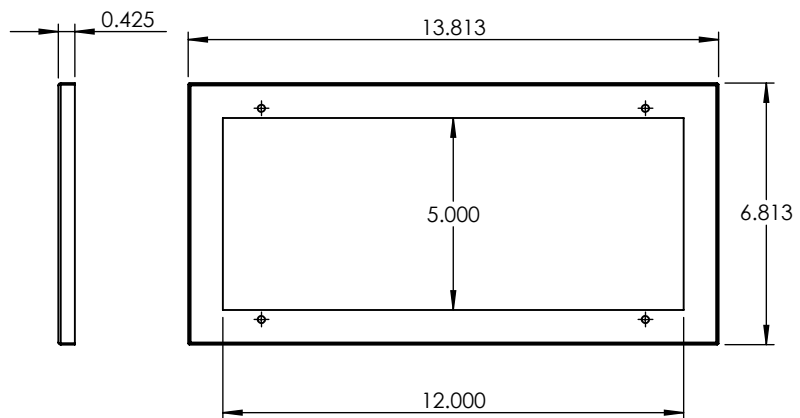
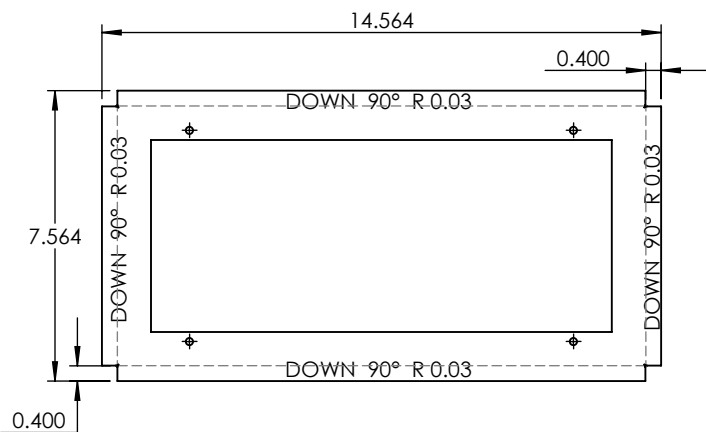

PROPRIETARY AND CONFIDENTIAL
 THE INFORMATION CONTAINED IN THIS DRAWING IS THE SOLE PROPERTY OF <INSERT COMPANY NAME HERE>. ANY REPRODUCTION IN PART OR AS A WHOLE WITHOUT THE WRITTEN PERMISSION OF <INSERT COMPANY NAME HERE> IS PROHIBITED.

		UNLESS OTHERWISE SPECIFIED:	NAME	DATE
		DIMENSIONS ARE IN INCHES	DRAWN	
		TOLERANCES:	CHECKED	
		FRACTIONAL ±	ENG APPR.	
		ANGULAR: MACH ± BEND ±	MFG APPR.	
		TWO PLACE DECIMAL ±	Q.A.	
		THREE PLACE DECIMAL ±	COMMENTS:	
		INTERPRET GEOMETRIC TOLERANCING PER:		
		MATERIAL		
NEXT ASSY	USED ON	FINISH		
APPLICATION		DO NOT SCALE DRAWING		

22 GAUGE

TITLE:
 STP-REC-LV9-14X7-6W-MG-CFA-40K

SIZE A	DWG. NO.	REV
SCALE: 1:5	WEIGHT:	SHEET 8 OF 8