

ITEM NO.	PART NUMBER	DESCRIPTION	QTY.	CUT
1	STN-ARM-4"-9W-ORB-CFA-40K-4" CYLINDER	4" ALUMINUM CYLINDER	1	
2	STN-ARM-4"-9W-ORB-CFA-40K-SPUN DOOR	SPUN ALUMINUM 0.0635"	1	
3	STN-ARM-4"-9W-ORB-CFA-40K-SPUN DOOR BRACKET	SPUN ALUMINUM 0.0635"	1	
4	STN-ARM-4"-9W-ORB-CFA-40K-DRIVER BRACKET	22 GAUGE	1	
5	STN-ARM-4"-9W-ORB-CFA-40K-BACKPLATE	22 GAUGE	1	
6	STN-ARM-4"-9W-ORB-CFA-40K-FIREPLATE	22 GAUGE	1	
7	STN-ARM-4"-9W-ORB-CFA-40K-LED BRACKET	22 GAUGE	1	
8	STN-ARM-4"-9W-ORB-CFA-40K-CONNECTOR BOX TOP	22 GAUGE	1	
9	STN-ARM-4"-9W-ORB-CFA-40K-CONNECTOR BOX BOTTOM	22 GAUGE	1	
10	STN-ARM-4"-9W-ORB-CFA-40K-BACKPLATE TAB	22 GAUGE	4	
11	STN-ARM-4"-9W-ORB-CFA-40K-ACRYLIC	ACRYLIC	1	
12	55MM HEXAGON HEAT SINK	HEAT SINK	1	
13	STN-ARM-4"-9W-ORB-CFA-40K-NIPPLE	1.5" NIPPLE	1	
14	DS-15W-350C1542010-3001	DRIVER	1	
15	AltGILED_PCN_D1500_110B-10 WATT	LED	1	

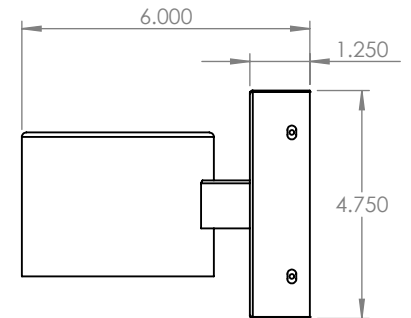
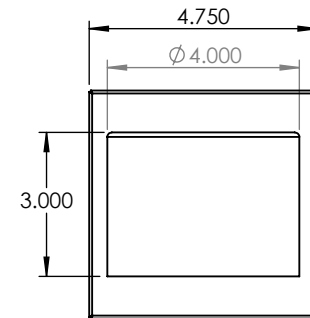
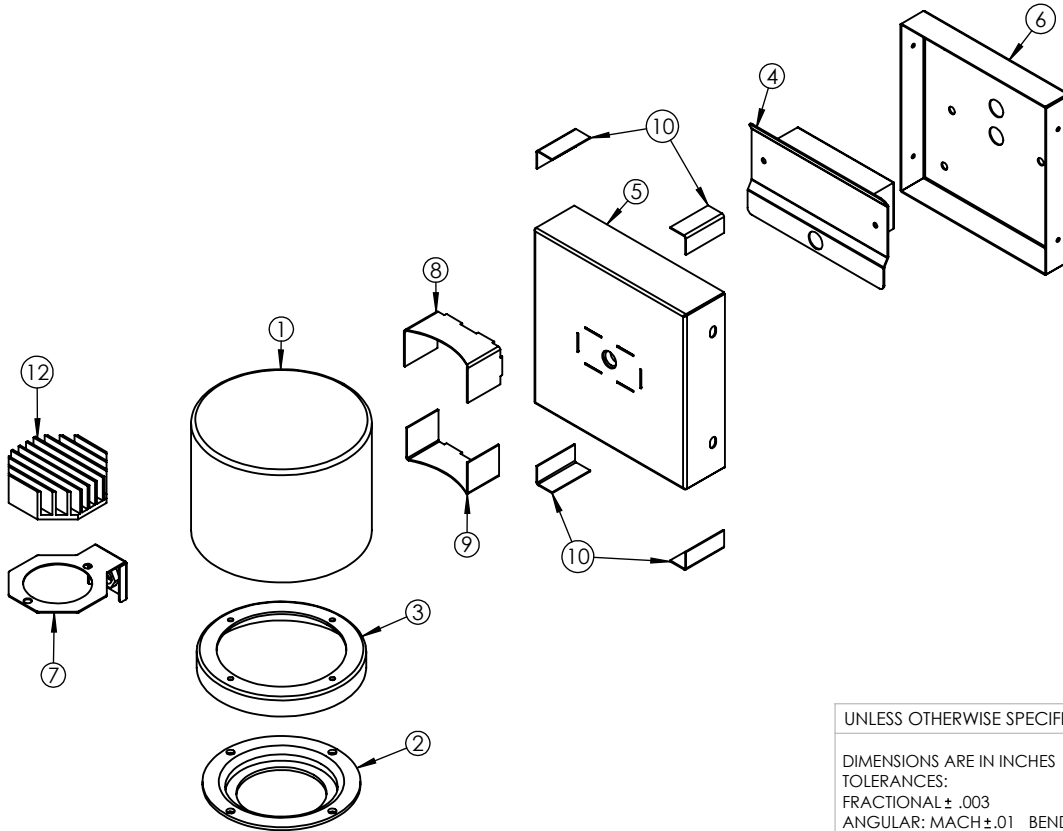
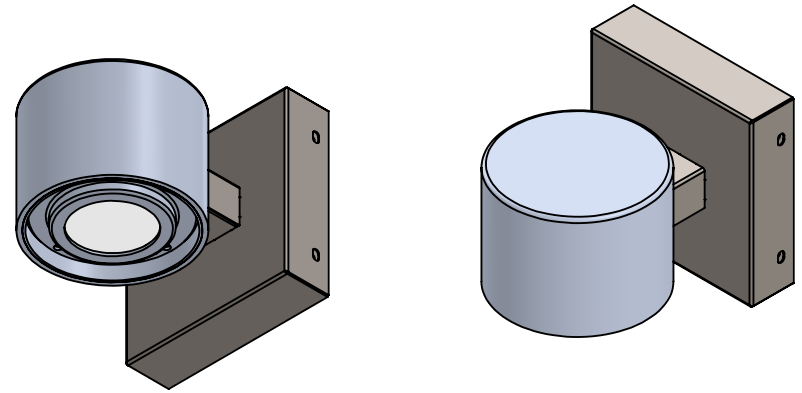

ALL BEND RADIUS .030"

APPLICATION

DO NOT SCALE DRAWING

UNLESS OTHERWISE SPECIFIED:

DIMENSIONS ARE IN INCHES
 TOLERANCES:
 FRACTIONAL ± .003
 ANGULAR: MACH ± .01 BEND ±
 TWO PLACE DECIMAL ±
 THREE PLACE DECIMAL ±.001

INTERPRET GEOMETRIC
 TOLERANCING PER:
 MATERIAL

FINISH

NAME DATE

DRAWN
 CHECKED
 ENG APPR.
 MFG APPR.

Q.A.
 COMMENTS:

TITLE:

STN-ARM-4"-9W-ORB-CFA-40K

SIZE DWG. NO. REV
A TICKET 26990

SCALE: 1:4 WEIGHT: SHEET 1 OF 9

5

4

3

2

1

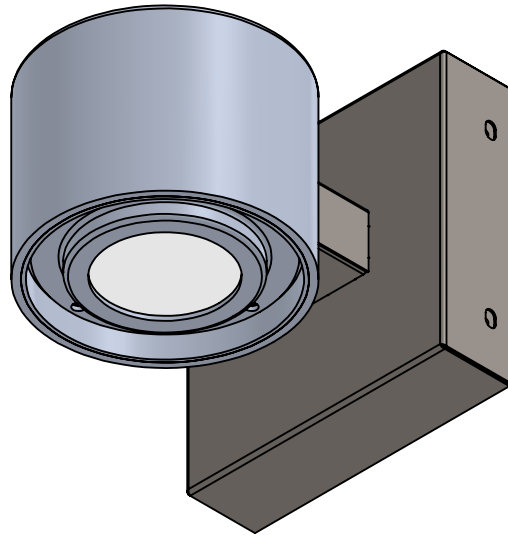
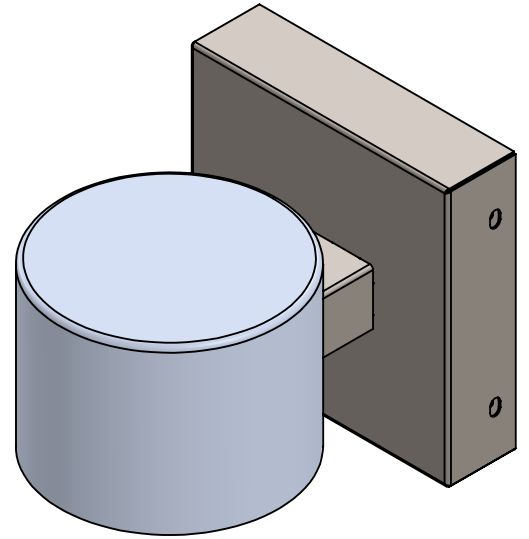
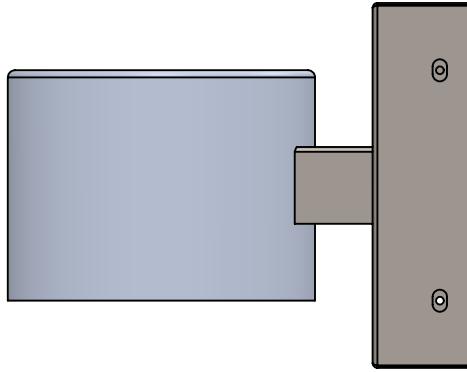
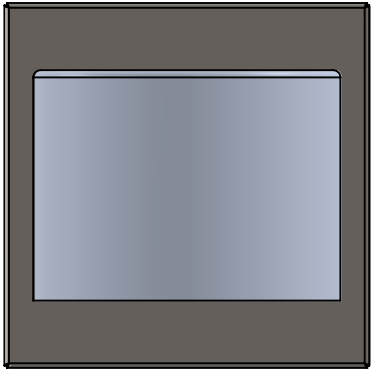

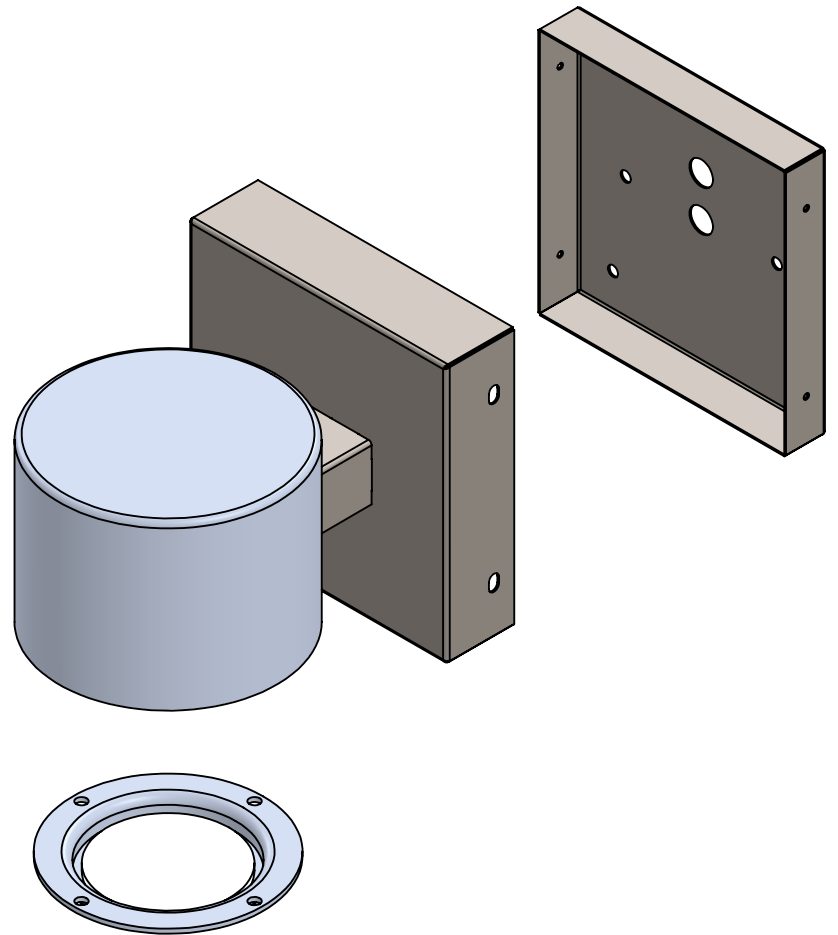
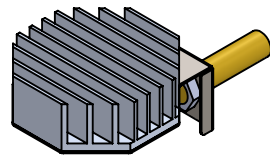
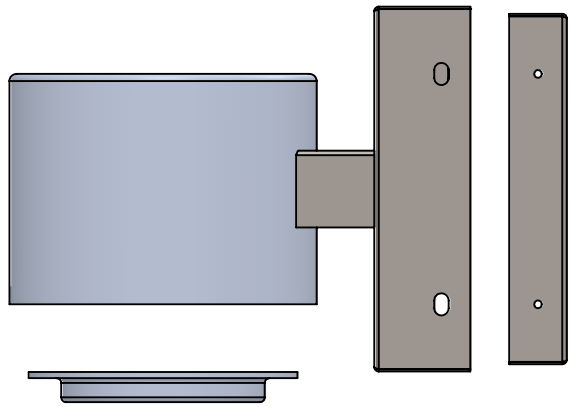

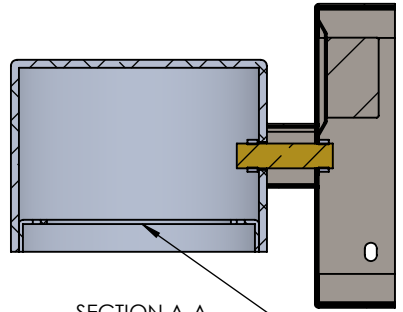
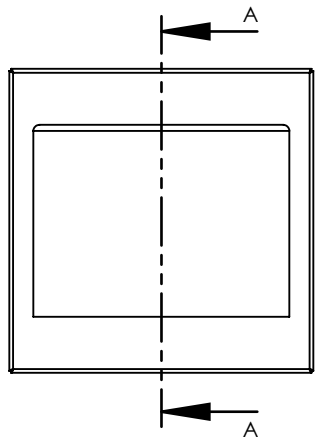
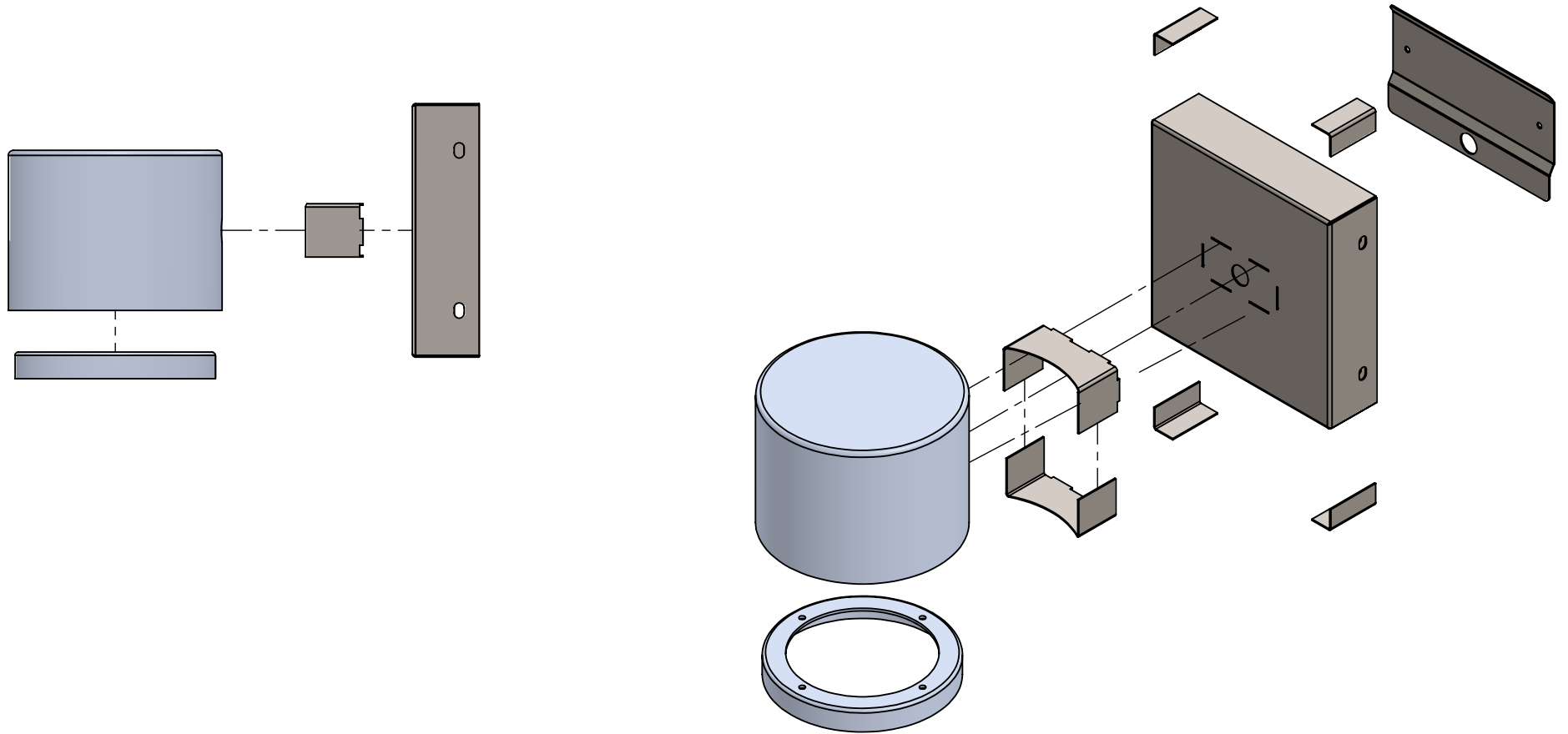

BRACKET REGRESSED 1/2" INTO
CYLINDER BODY

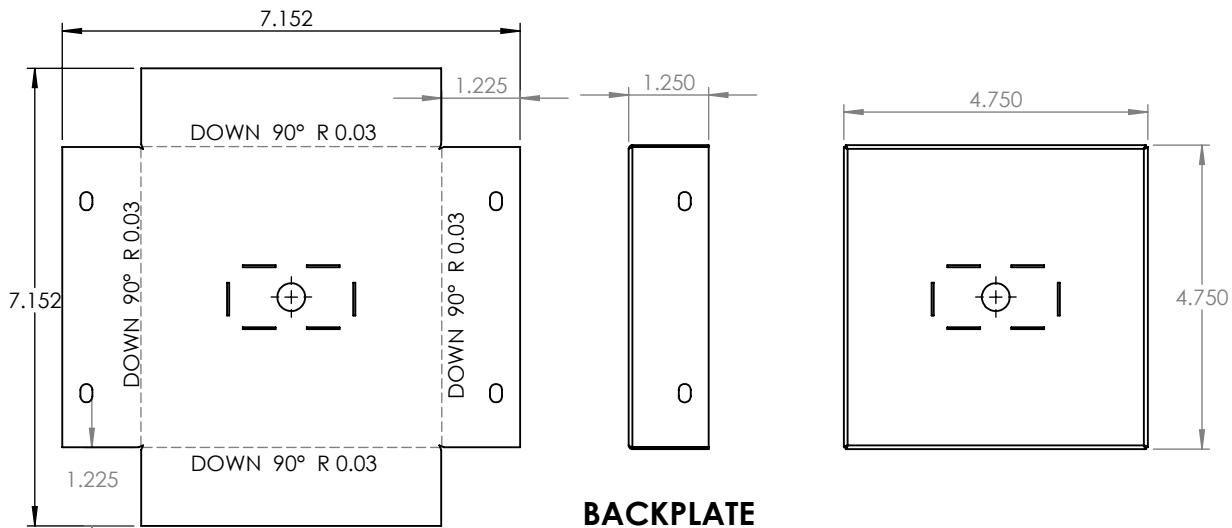

BACKPLATE

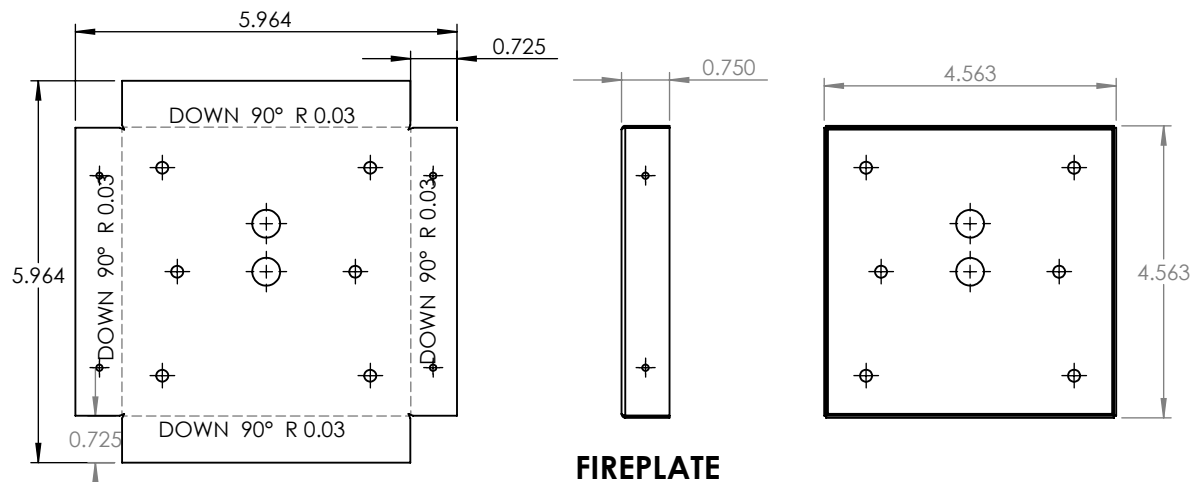
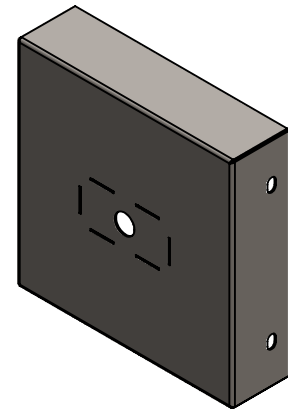

FIREPLATE

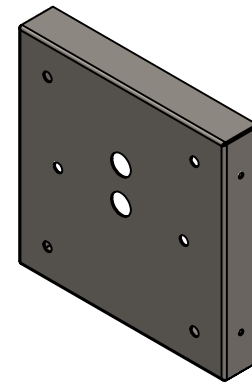

PROPRIETARY AND CONFIDENTIAL
 THE INFORMATION CONTAINED IN THIS DRAWING IS THE SOLE PROPERTY OF <INSERT COMPANY NAME HERE>. ANY REPRODUCTION IN PART OR AS A WHOLE WITHOUT THE WRITTEN PERMISSION OF <INSERT COMPANY NAME HERE> IS PROHIBITED.

		UNLESS OTHERWISE SPECIFIED:		NAME	DATE
		DIMENSIONS ARE IN INCHES	DRAWN		
		TOLERANCES:	CHECKED		
		FRACTIONAL ±	ENG APPR.		
		ANGULAR: MACH ± BEND ±	MFG APPR.		
		TWO PLACE DECIMAL ±	Q.A.		
		THREE PLACE DECIMAL ±	COMMENTS:		
		INTERPRET GEOMETRIC TOLERANCING PER:			
		MATERIAL			
NEXT ASSY	USED ON	FINISH			
APPLICATION		DO NOT SCALE DRAWING			

22 GAUGE		
TITLE:		
STN-ARM-4"-9W-ORB-CFA-40K		
SIZE	DWG. NO.	REV
A		
SCALE: 1:3	WEIGHT:	SHEET 5 OF 9

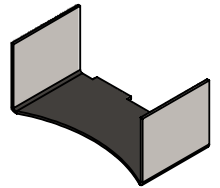
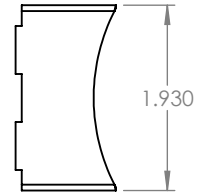
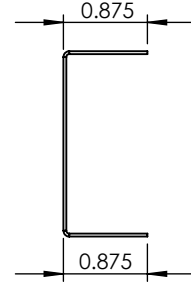
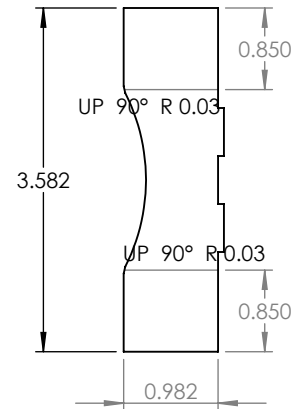
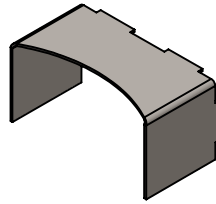
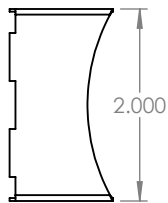
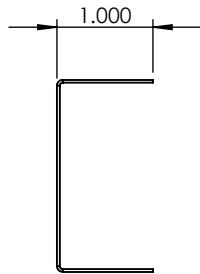
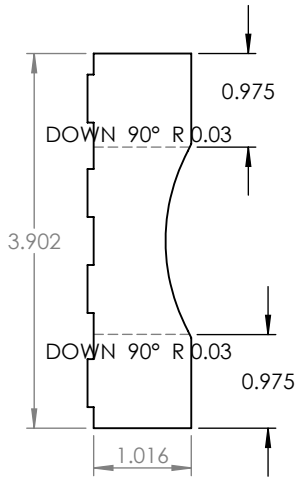
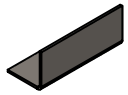
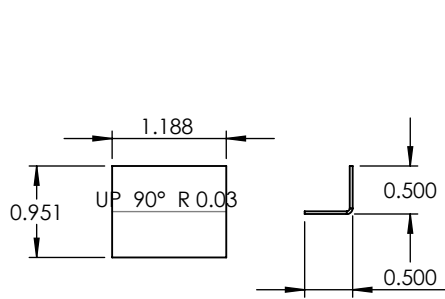

CONNECTOR BOX TOP AND BOTTOM

PROPRIETARY AND CONFIDENTIAL
 THE INFORMATION CONTAINED IN THIS DRAWING IS THE SOLE PROPERTY OF <INSERT COMPANY NAME HERE>. ANY REPRODUCTION IN PART OR AS A WHOLE WITHOUT THE WRITTEN PERMISSION OF <INSERT COMPANY NAME HERE> IS PROHIBITED.

		UNLESS OTHERWISE SPECIFIED:	NAME	DATE
		DIMENSIONS ARE IN INCHES	DRAWN	
		TOLERANCES:	CHECKED	
		FRACTIONAL ±	ENG APPR.	
		ANGULAR: MACH ± BEND ±	MFG APPR.	
		TWO PLACE DECIMAL ±	Q.A.	
		THREE PLACE DECIMAL ±	COMMENTS:	
		INTERPRET GEOMETRIC TOLERANCING PER:		
		MATERIAL		
NEXT ASSY	USED ON	FINISH		
APPLICATION		DO NOT SCALE DRAWING		

22 GAUGE		
TITLE: STN-ARM-4"-9W-ORB-CFA-40K		
SIZE A	DWG. NO.	REV
SCALE: 1:2	WEIGHT:	SHEET 6 OF 9

5

4

3

2

1

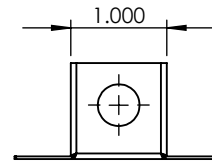
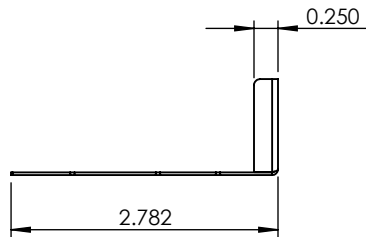
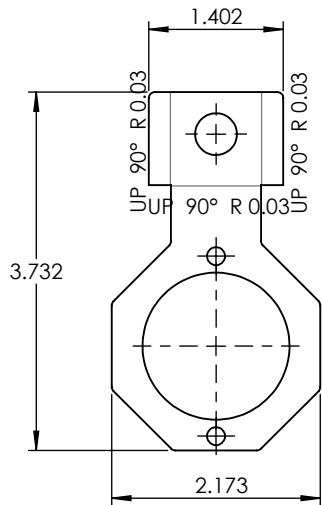
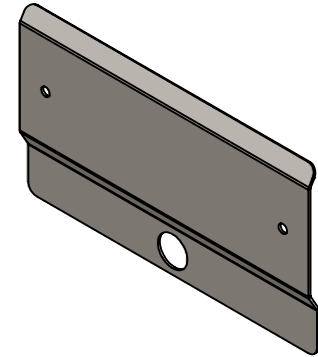
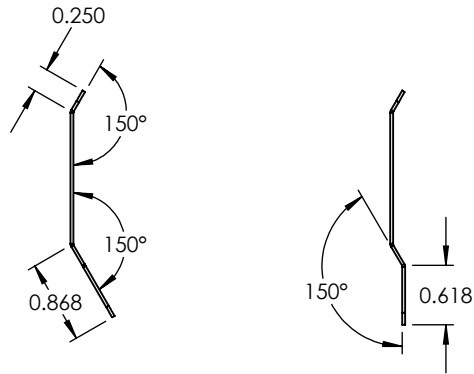
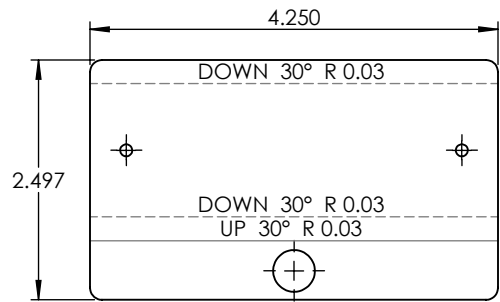

UNLESS OTHERWISE SPECIFIED:

DIMENSIONS ARE IN INCHES
 TOLERANCES:
 FRACTIONAL ±
 ANGULAR: MACH ± BEND ±
 TWO PLACE DECIMAL ±
 THREE PLACE DECIMAL ±

INTERPRET GEOMETRIC
 TOLERANCING PER:

MATERIAL

FINISH

DO NOT SCALE DRAWING

NAME DATE

DRAWN

CHECKED

ENG APPR.

MFG APPR.

Q.A.

COMMENTS:

TITLE:

STN-ARM-4"-9W-ORB-CFA-40K

SIZE DWG. NO.

REV

SCALE: 1:2 WEIGHT:

SHEET 7 OF 9

PROPRIETARY AND CONFIDENTIAL
 THE INFORMATION CONTAINED IN THIS
 DRAWING IS THE SOLE PROPERTY OF
 <INSERT COMPANY NAME HERE>. ANY
 REPRODUCTION IN PART OR AS A WHOLE
 WITHOUT THE WRITTEN PERMISSION OF
 <INSERT COMPANY NAME HERE> IS
 PROHIBITED.

NEXT ASSY

USED ON

APPLICATION

ITEM NO.	PART NUMBER	DESCRIPTION	QTY.
1	STN-ARM-4"-9W-ORB-CFA-40K-4" CYLINDER	4" ALUMINUM CYLINDER	1

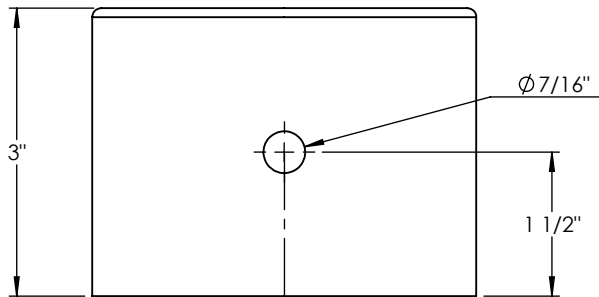
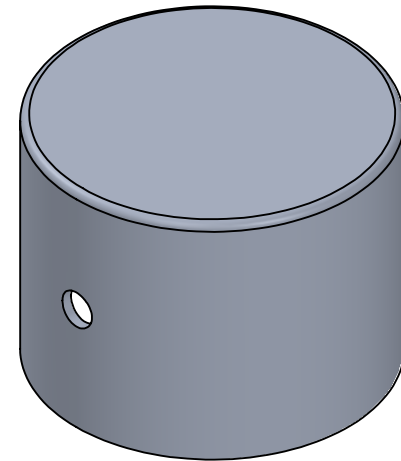
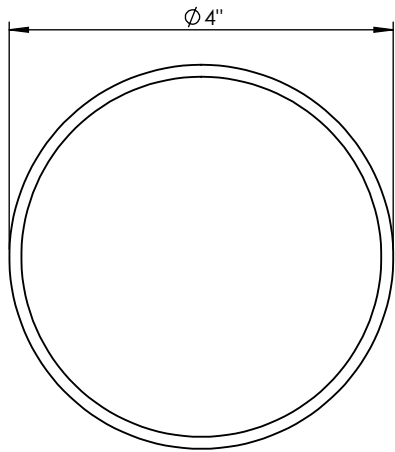

UNLESS OTHERWISE SPECIFIED:		NAME	DATE	4" ALUMINUM CYLINDER	
DIMENSIONS ARE IN INCHES		DRAWN		TITLE: STN-ARM-4"-9W-ORB-CFA-40K	
TOLERANCES:		CHECKED			
FRACTIONAL \pm		ENG APPR.			
ANGULAR: MACH \pm BEND \pm		MFG APPR.			
TWO PLACE DECIMAL \pm		Q.A.		SIZE DWG. NO. REV	
THREE PLACE DECIMAL \pm		COMMENTS:		SCALE: 1:2 WEIGHT: SHEET 8 OF 9	
INTERPRET GEOMETRIC TOLERANCING PER:					
MATERIAL					
FINISH					
APPLICATION					
DO NOT SCALE DRAWING					

PROPRIETARY AND CONFIDENTIAL
 THE INFORMATION CONTAINED IN THIS DRAWING IS THE SOLE PROPERTY OF <INSERT COMPANY NAME HERE>. ANY REPRODUCTION IN PART OR AS A WHOLE WITHOUT THE WRITTEN PERMISSION OF <INSERT COMPANY NAME HERE> IS PROHIBITED.

ITEM NO.	PART NUMBER	DESCRIPTION	QTY.
1	STN-ARM-4"-9W-ORB-CFA-40K-SPUN DOOR	SPUN ALUMINUM 0.0635"	1

ITEM NO.	PART NUMBER	DESCRIPTION	QTY.
1	STN-ARM-4"-9W-ORB-CFA-40K-SPUN DOOR BRACKET	SPUN ALUMINUM 0.0635"	1

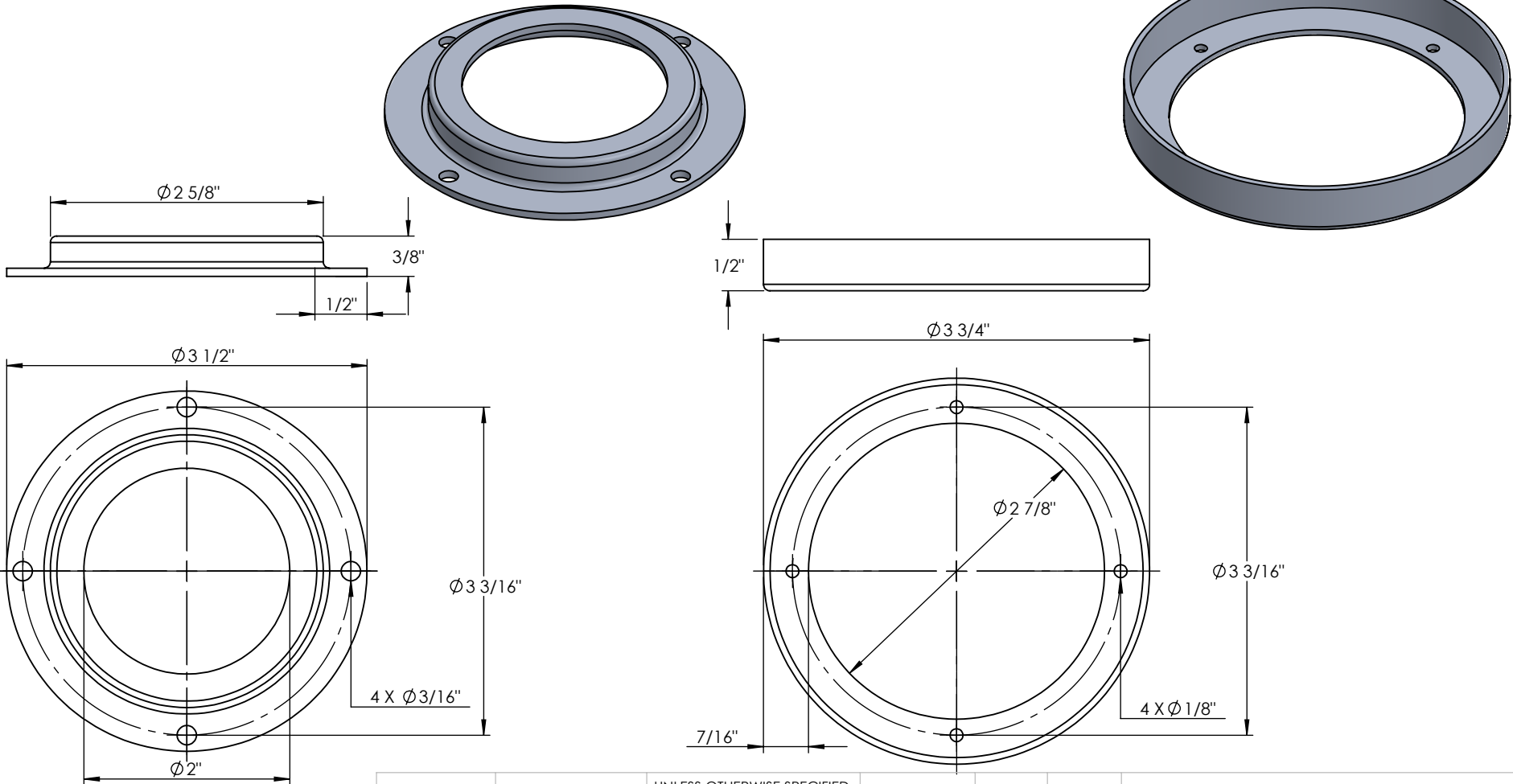

PROPRIETARY AND CONFIDENTIAL
 THE INFORMATION CONTAINED IN THIS DRAWING IS THE SOLE PROPERTY OF <INSERT COMPANY NAME HERE>. ANY REPRODUCTION IN PART OR AS A WHOLE WITHOUT THE WRITTEN PERMISSION OF <INSERT COMPANY NAME HERE> IS PROHIBITED.

		UNLESS OTHERWISE SPECIFIED:		NAME	DATE
		DIMENSIONS ARE IN INCHES		DRAWN	
		TOLERANCES:		CHECKED	
		FRACTIONAL ±		ENG APPR.	
		ANGULAR: MACH ± BEND ±		MFG APPR.	
		TWO PLACE DECIMAL ±		Q.A.	
		THREE PLACE DECIMAL ±		COMMENTS:	
		INTERPRET GEOMETRIC TOLERANCING PER:			
		MATERIAL			
		FINISH			
NEXT ASSY	USED ON				
APPLICATION	DO NOT SCALE DRAWING				

SPUN ALUMINUM 0.0635"		
TITLE:		
STN-ARM-4"-9W-ORB-CFA-40K		
SIZE	DWG. NO.	REV
A		
SCALE: 1:1.5WEIGHT:		SHEET 9 OF 9