

ALL BEND RADIUS .030"

APPLICATION

DO NOT SCALE DRAWING

UNLESS OTHERWISE SPECIFIED:

DIMENSIONS ARE IN INCHES
 TOLERANCES:
 FRACTIONAL ± .003
 ANGULAR: MACH ± .01 BEND ±
 TWO PLACE DECIMAL ±
 THREE PLACE DECIMAL ±.001

INTERPRET GEOMETRIC
 TOLERANCING PER:

MATERIAL

FINISH

NAME

DATE

DRAWN

CHECKED

ENG APPR.

MFG APPR.

Q.A.

COMMENTS:

FIXTURE HEAD

TITLE:

COZ2110L-AB-A-PC-41K

SIZE DWG. NO.

REV

A TICKET 26999

SCALE: 1:7 WEIGHT:

SHEET 1 OF 15

5

4

3

2

1

ITEM NO.	PART NUMBER	DESCRIPTION	QTY.	CUT
1	COZ2110L-AB-A-PC-41K-TOP SPUN BOWL	SPUN ALUMINUM 0.0635"	1	
2	COZ2110L-AB-A-PC-41K-TOP SPUN CUP	SPUN ALUMINUM 0.0635"	1	
3	COZ2110L-AB-A-PC-41K-BACKPLATE	22 GAUGE	1	
4	COZ2110L-AB-A-PC-41K-BACKPLATE TAB	22 GAUGE	4	
5	COZ2110L-AB-A-PC-41K-DRIVER BRACKET	22 GAUGE	1	
6	COZ2110L-AB-A-PC-41K-FIREPLATE	22 GAUGE	1	
7	COZ2110L-AB-A-PC-41K-TOP CAP	22 GAUGE	1	
8	COZ2110L-AB-A-PC-41K-FRAME TOP BEND	22 GAUGE	4	
9	COZ2109LS-AB-A-PE-30K-FRAME TOP SENSOR	22 GAUGE	1	
10	COZ2110L-AB-A-PC-41K-FRAME TOP BACK	22 GAUGE	1	
11	COZ2110L-AB-A-PC-41K-FRAME TABS	22 GAUGE	6	
12	COZ2110L-AB-A-PC-41K-DOOR	22 GAUGE	1	
13	COZ2110L-AB-A-PC-41K-FRAME BOTTOM BEND	22 GAUGE	6	
14	COZ2110L-AB-A-PC-41K-BOTTOM CAP	22 GAUGE	1	
15	COZ2110L-AB-A-PC-41K-BRACKET TABS	22 GAUGE	2	
16	COZ2110L-AB-A-PC-41K-LED BRACKET	22 GAUGE	1	
17	COZ2110L-AB-A-PC-41K-TUBE BRACKET	22 GAUGE	1	
18	COZ2110L-AB-A-PC-41K-ACRYLIC	ACRYLIC	6	
19	COZ2110L-AB-A-PC-41K-0.625" ROUND TUBE	5/8" ALUMINUM TUBE	2	
20	COZ2110L-AB-A-PC-41K-0.625" ROUND TUBE	5/8" ALUMINUM TUBE	1	
21	COZ2110L-AB-A-PC-41K-SQUARE TUBE	1" SQUARE ALUMINUM TUBE	1	
22	.375 BRASS BALL	3/8" BRASS BALL	2	
23	Espen VEL19070MVH-1	DRIVER	1	
24	AltalLED_PN1012_RevD	LED	4	
26	PHOTO CELL MODEL 2.0	SENSOR	1	

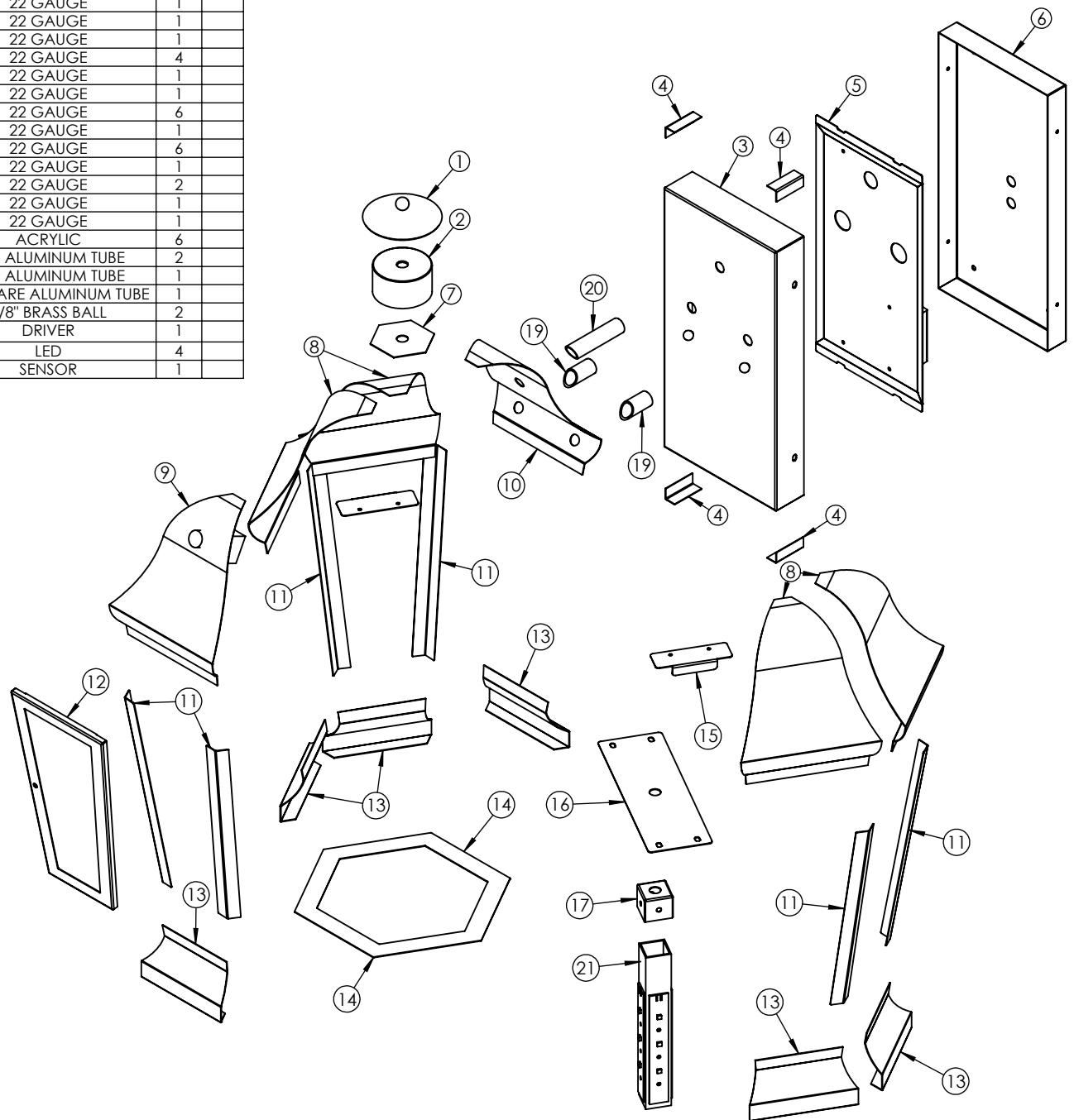

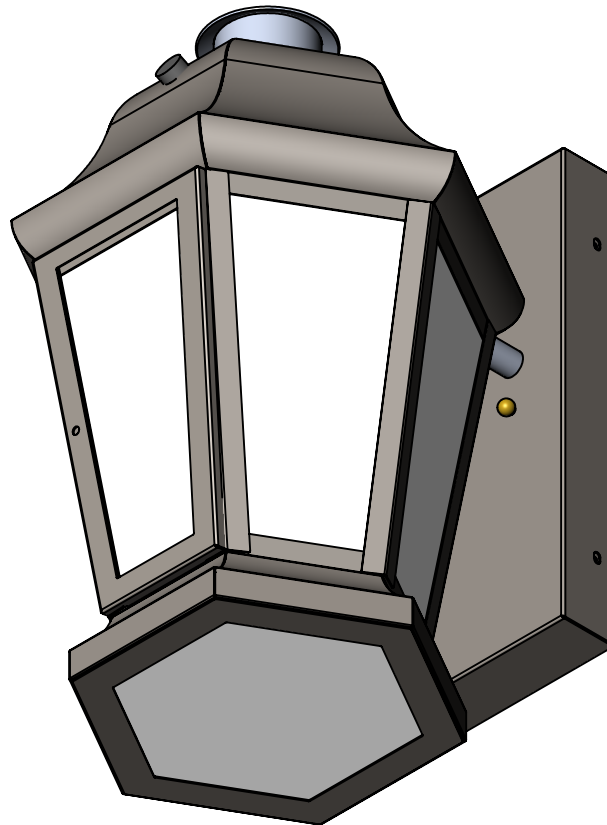
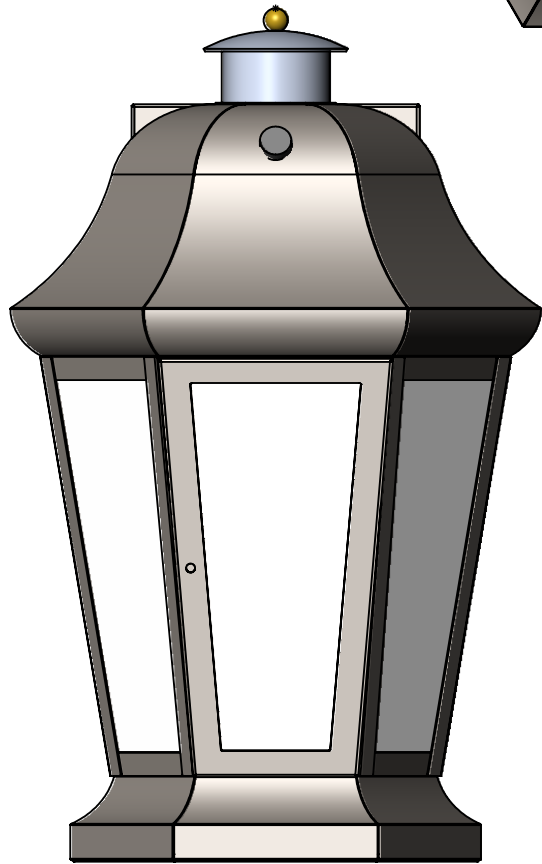
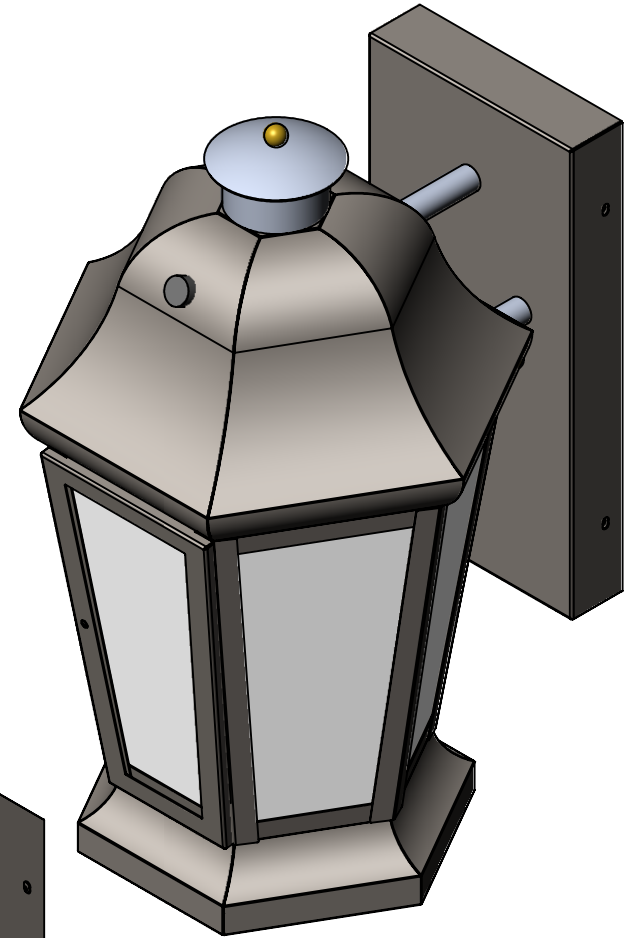
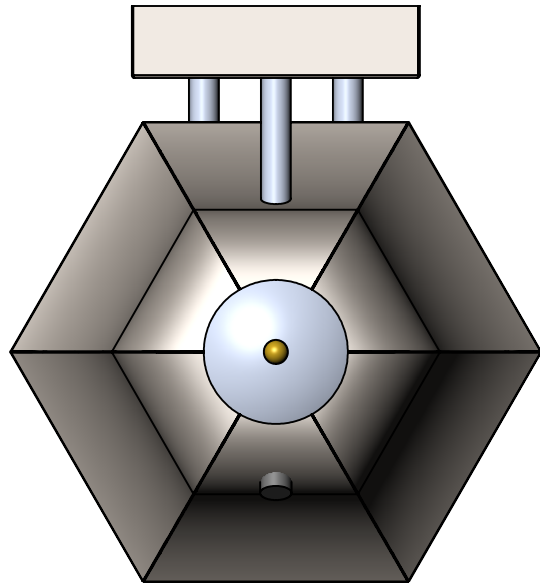

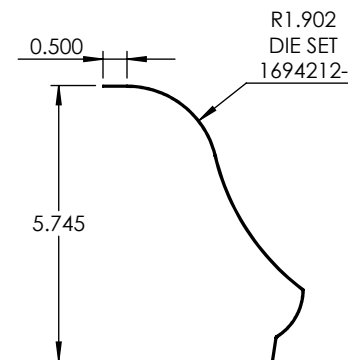
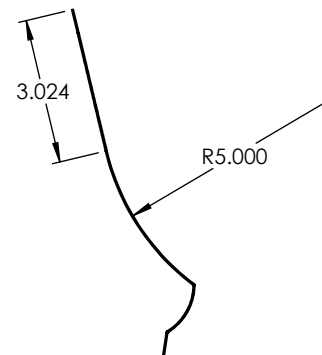
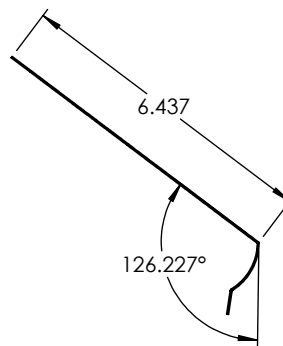
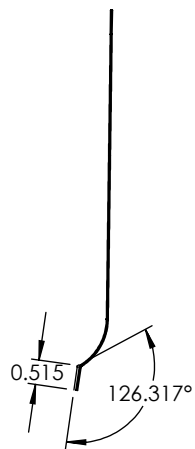
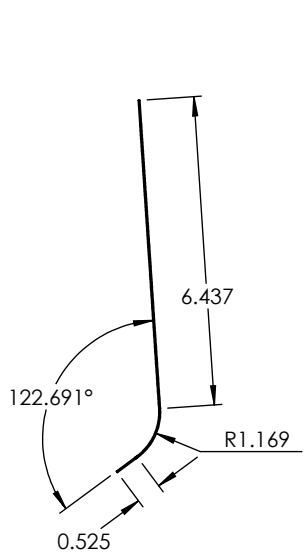
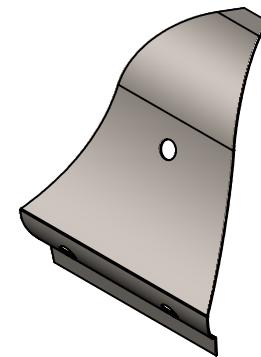
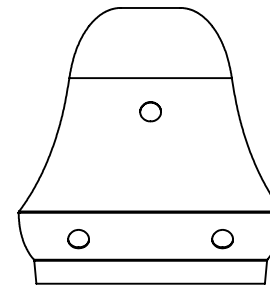
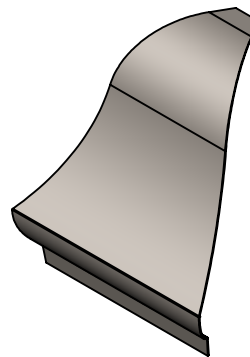
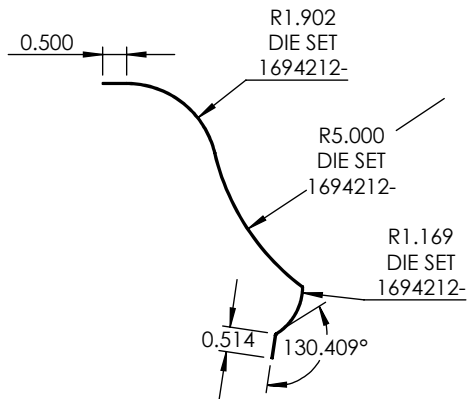
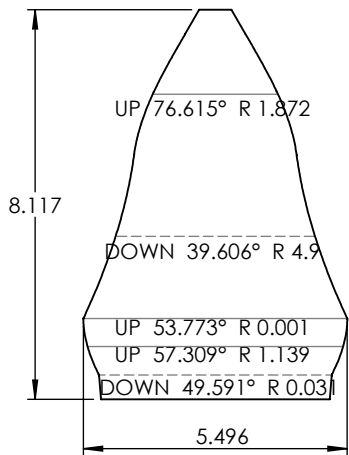

PROPRIETARY AND CONFIDENTIAL
 THE INFORMATION CONTAINED IN THIS DRAWING IS THE SOLE PROPERTY OF <INSERT COMPANY NAME HERE>. ANY REPRODUCTION IN PART OR AS A WHOLE WITHOUT THE WRITTEN PERMISSION OF <INSERT COMPANY NAME HERE> IS PROHIBITED.

		UNLESS OTHERWISE SPECIFIED:		NAME	DATE
		DIMENSIONS ARE IN INCHES	DRAWN		
		TOLERANCES:	CHECKED		
		FRACTIONAL ±	ENG APPR.		
		ANGULAR: MACH ± BEND ±	MFG APPR.		
		TWO PLACE DECIMAL ±	Q.A.		
		THREE PLACE DECIMAL ±	COMMENTS:		
		INTERPRET GEOMETRIC TOLERANCING PER:			
		MATERIAL			
NEXT ASSY	USED ON	FINISH			
APPLICATION		DO NOT SCALE DRAWING			

22 GAUGE

TITLE:

COZ2110L-AB-A-PC-41K

SIZE
A

DWG. NO.

REV

SCALE: 1:4

WEIGHT:

SHEET 5 OF 15

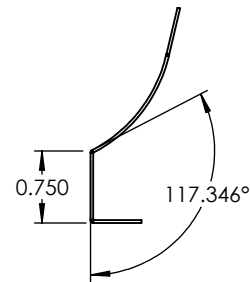
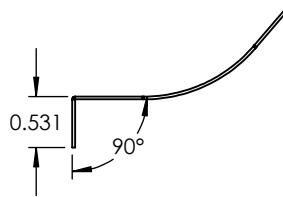
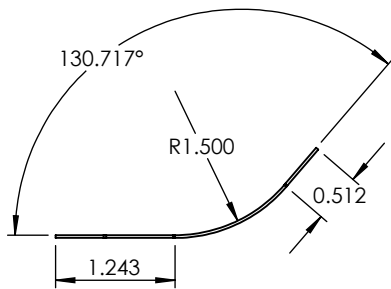
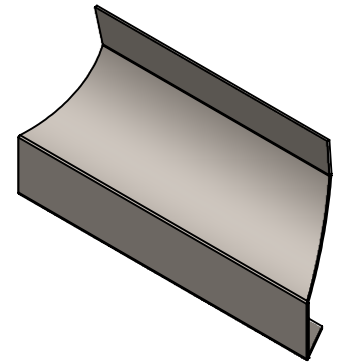
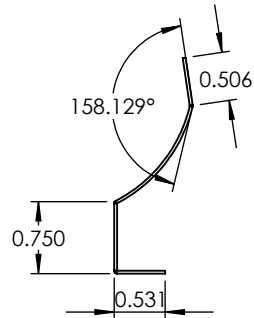
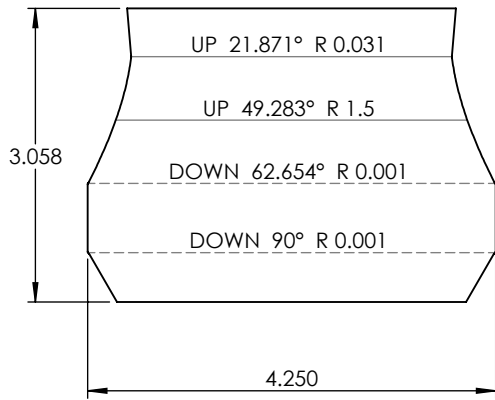

PROPRIETARY AND CONFIDENTIAL
 THE INFORMATION CONTAINED IN THIS DRAWING IS THE SOLE PROPERTY OF <INSERT COMPANY NAME HERE>. ANY REPRODUCTION IN PART OR AS A WHOLE WITHOUT THE WRITTEN PERMISSION OF <INSERT COMPANY NAME HERE> IS PROHIBITED.

		UNLESS OTHERWISE SPECIFIED:		NAME	DATE	22 GAUGE	
		DIMENSIONS ARE IN INCHES TOLERANCES: FRACTIONAL ± ANGULAR: MACH ± BEND ± TWO PLACE DECIMAL ± THREE PLACE DECIMAL ±		DRAWN			
		INTERPRET GEOMETRIC TOLERANCING PER:		CHECKED		SIZE DWG. NO. REV	
		MATERIAL		ENG APPR.			
		FINISH		MFG APPR.			
NEXT ASSY	USED ON			Q.A.			
APPLICATION		DO NOT SCALE DRAWING		COMMENTS:			

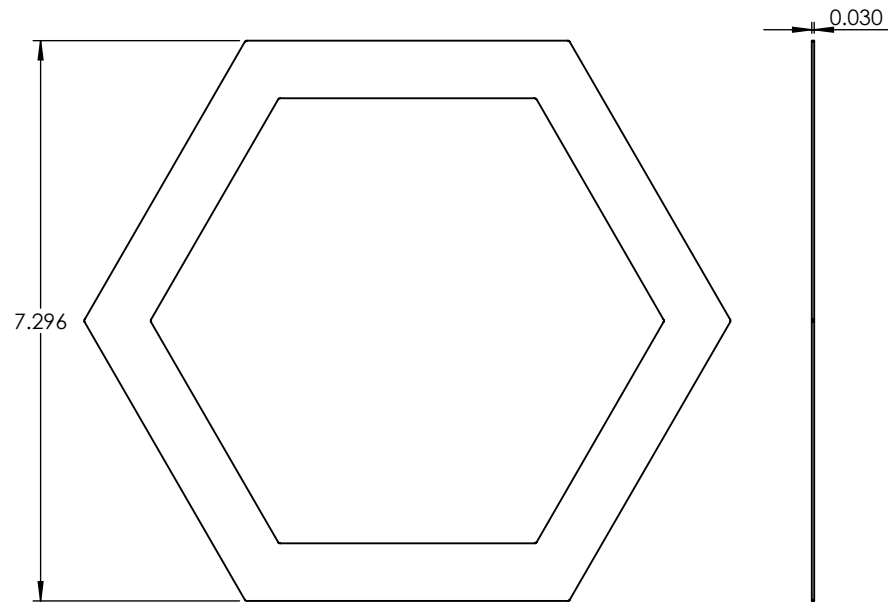
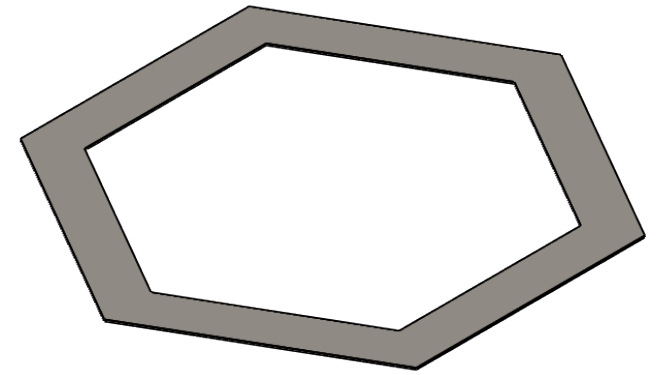
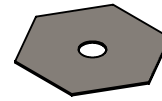
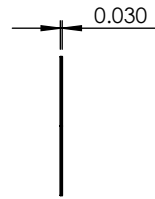
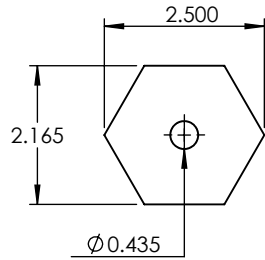
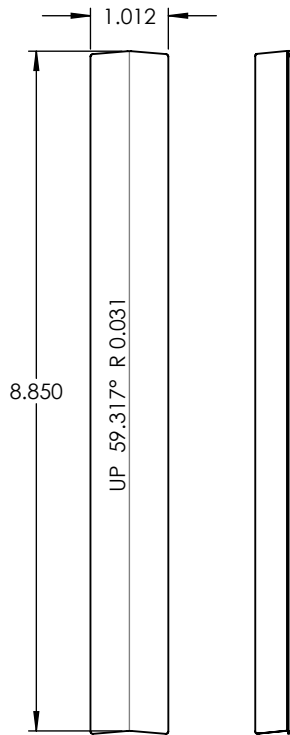
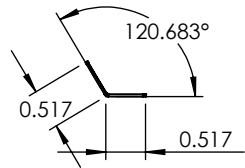

PROPRIETARY AND CONFIDENTIAL
 THE INFORMATION CONTAINED IN THIS DRAWING IS THE SOLE PROPERTY OF <INSERT COMPANY NAME HERE>. ANY REPRODUCTION IN PART OR AS A WHOLE WITHOUT THE WRITTEN PERMISSION OF <INSERT COMPANY NAME HERE> IS PROHIBITED.

		UNLESS OTHERWISE SPECIFIED:		NAME	DATE	22 GAUGE		
		DIMENSIONS ARE IN INCHES TOLERANCES: FRACTIONAL ± ANGULAR: MACH ± BEND ± TWO PLACE DECIMAL ± THREE PLACE DECIMAL ±	DRAWN					TITLE: COZ21 10L-AB-A-PC-41K
		INTERPRET GEOMETRIC TOLERANCING PER:	CHECKED			A	DWG. NO.	
		MATERIAL	ENG APPR.					SCALE: 1:2.5WEIGHT:
		FINISH	MFG APPR.					
		APPLICATION	Q.A.					
		DO NOT SCALE DRAWING	COMMENTS:					
	NEXT ASSY	USED ON						

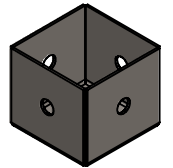
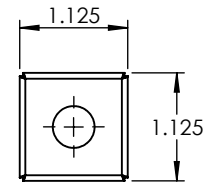
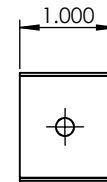
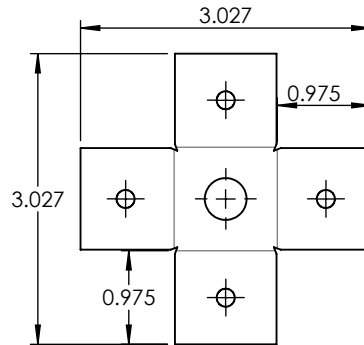
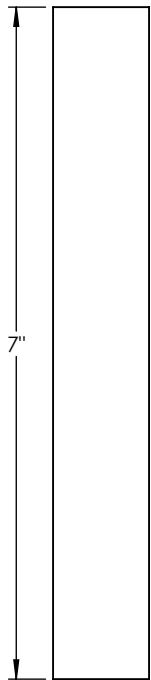
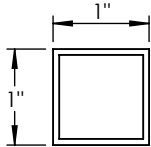
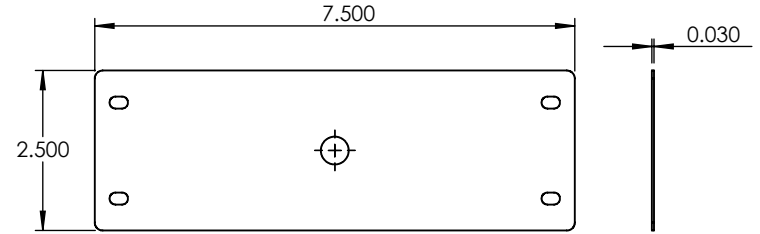
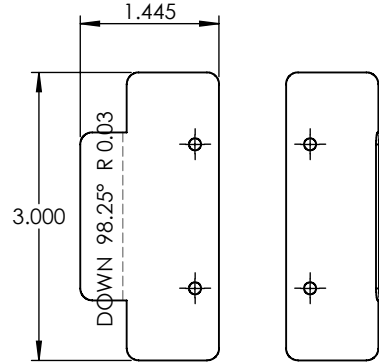
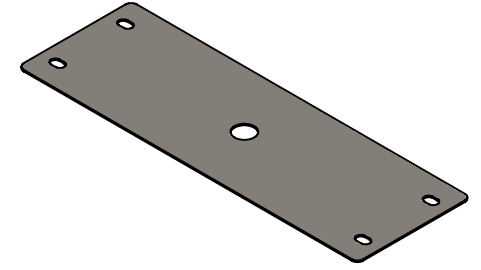
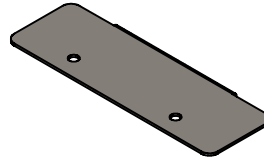
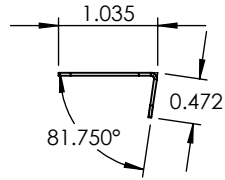

UNLESS OTHERWISE SPECIFIED:		NAME	DATE	1" SQUARE ALUMINUM TUBE			
DIMENSIONS ARE IN INCHES TOLERANCES: FRACTIONAL ± ANGULAR: MACH ± BEND ± TWO PLACE DECIMAL ± THREE PLACE DECIMAL ±		DRAWN				TITLE:	
INTERPRET GEOMETRIC TOLERANCING PER:		CHECKED		COZ2110L-AB-A-PC-41K			
MATERIAL		ENG APPR.					
FINISH		MFG APPR.		SIZE	DWG. NO.	REV	
NEXT ASSY		USED ON		A	SCALE: 1:3	WEIGHT:	SHEET 8 OF 15
APPLICATION		DO NOT SCALE DRAWING					

PROPRIETARY AND CONFIDENTIAL
THE INFORMATION CONTAINED IN THIS DRAWING IS THE SOLE PROPERTY OF <INSERT COMPANY NAME HERE>. ANY REPRODUCTION IN PART OR AS A WHOLE WITHOUT THE WRITTEN PERMISSION OF <INSERT COMPANY NAME HERE> IS PROHIBITED.

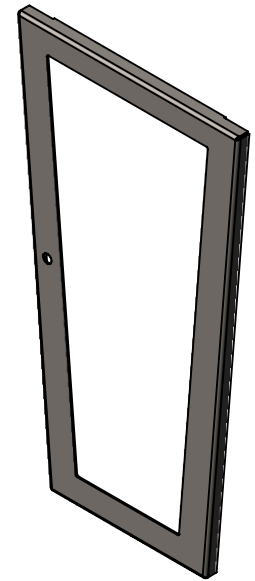
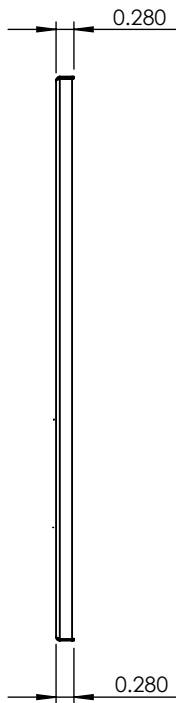
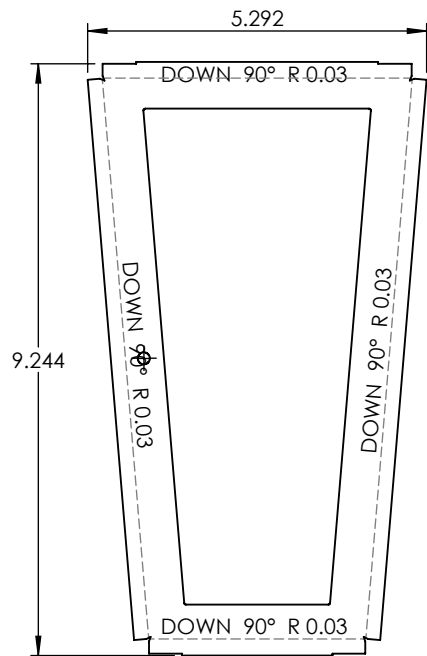

PROPRIETARY AND CONFIDENTIAL
 THE INFORMATION CONTAINED IN THIS DRAWING IS THE SOLE PROPERTY OF <INSERT COMPANY NAME HERE>. ANY REPRODUCTION IN PART OR AS A WHOLE WITHOUT THE WRITTEN PERMISSION OF <INSERT COMPANY NAME HERE> IS PROHIBITED.

		UNLESS OTHERWISE SPECIFIED:	NAME	DATE	22 GAUGE		
		DIMENSIONS ARE IN INCHES TOLERANCES: FRACTIONAL ± ANGULAR: MACH ± BEND ± TWO PLACE DECIMAL ± THREE PLACE DECIMAL ±	DRAWN				TITLE:
		INTERPRET GEOMETRIC TOLERANCING PER:	CHECKED		COZ2110L-AB-A-PC-41K		
		MATERIAL	ENG APPR.				
		FINISH	MFG APPR.		SIZE	DWG. NO.	REV
NEXT ASSY	USED ON		Q.A.		A		
APPLICATION		DO NOT SCALE DRAWING	COMMENTS:			SCALE: 1:3	WEIGHT:

5

4

3

2

1

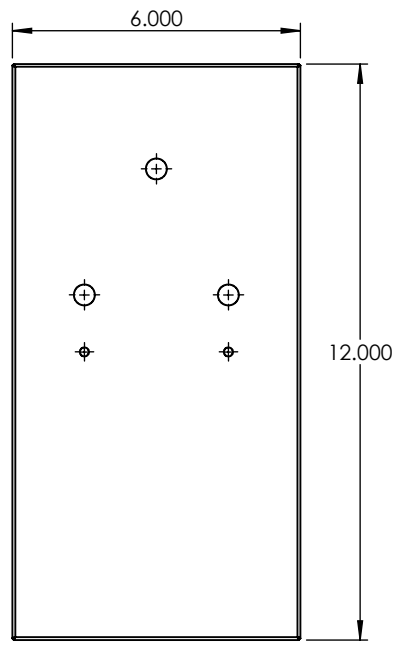
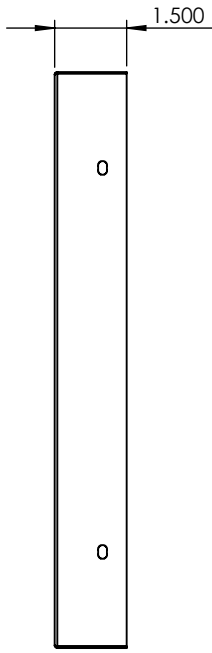
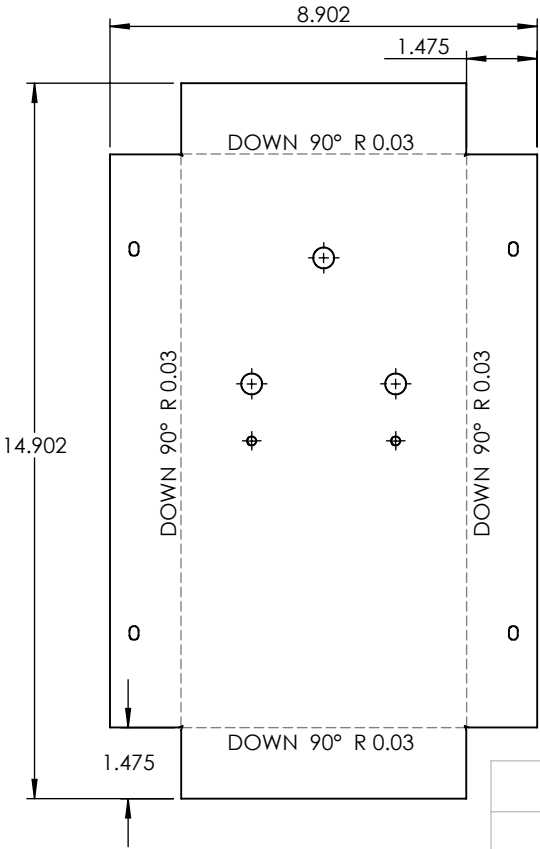
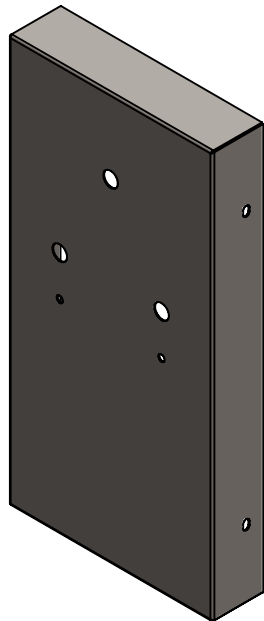
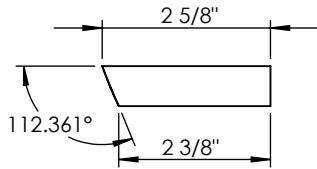
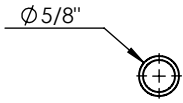
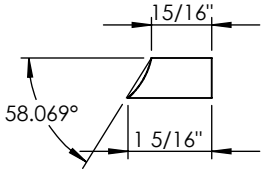
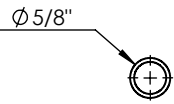

PROPRIETARY AND CONFIDENTIAL
 THE INFORMATION CONTAINED IN THIS DRAWING IS THE SOLE PROPERTY OF <INSERT COMPANY NAME HERE>. ANY REPRODUCTION IN PART OR AS A WHOLE WITHOUT THE WRITTEN PERMISSION OF <INSERT COMPANY NAME HERE> IS PROHIBITED.

		UNLESS OTHERWISE SPECIFIED:	NAME	DATE
		DIMENSIONS ARE IN INCHES	DRAWN	
		TOLERANCES:	CHECKED	
		FRACTIONAL ±	ENG APPR.	
		ANGULAR: MACH ± BEND ±	MFG APPR.	
		TWO PLACE DECIMAL ±	Q.A.	
		THREE PLACE DECIMAL ±	COMMENTS:	
		INTERPRET GEOMETRIC TOLERANCING PER:		
		MATERIAL		
		FINISH		
NEXT ASSY	USED ON			
APPLICATION	DO NOT SCALE DRAWING			

22 GAUGE		
TITLE: COZ2110L-AB-A-PC-41K		
SIZE A	DWG. NO.	REV
SCALE: 1:4	WEIGHT:	SHEET 10 OF 15

5

4

3

2

1

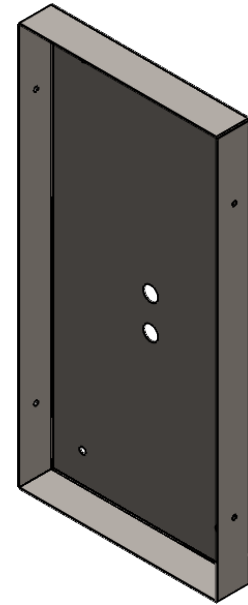
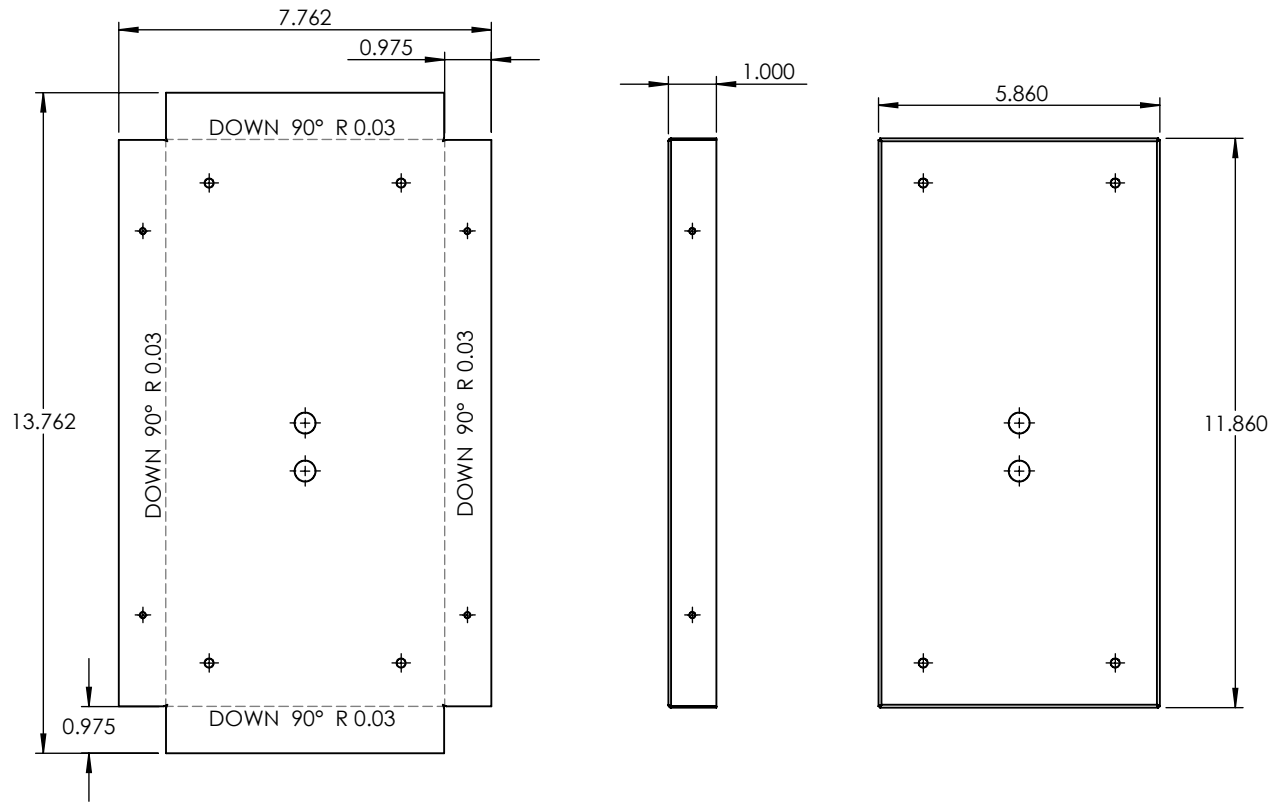

PROPRIETARY AND CONFIDENTIAL
 THE INFORMATION CONTAINED IN THIS DRAWING IS THE SOLE PROPERTY OF <INSERT COMPANY NAME HERE>. ANY REPRODUCTION IN PART OR AS A WHOLE WITHOUT THE WRITTEN PERMISSION OF <INSERT COMPANY NAME HERE> IS PROHIBITED.

		UNLESS OTHERWISE SPECIFIED:		NAME	DATE	22 GAUGE	
		DIMENSIONS ARE IN INCHES TOLERANCES: FRACTIONAL ± ANGULAR: MACH ± BEND ± TWO PLACE DECIMAL ± THREE PLACE DECIMAL ±		DRAWN			
		INTERPRET GEOMETRIC TOLERANCING PER:		CHECKED		SIZE DWG. NO. REV	
		MATERIAL		ENG APPR.			
		FINISH		MFG APPR.		COMMENTS:	
NEXT ASSY	USED ON			Q.A.			
APPLICATION		DO NOT SCALE DRAWING					

5

4

3

2

1

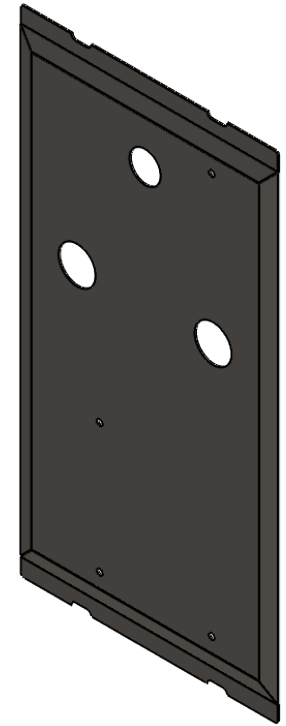
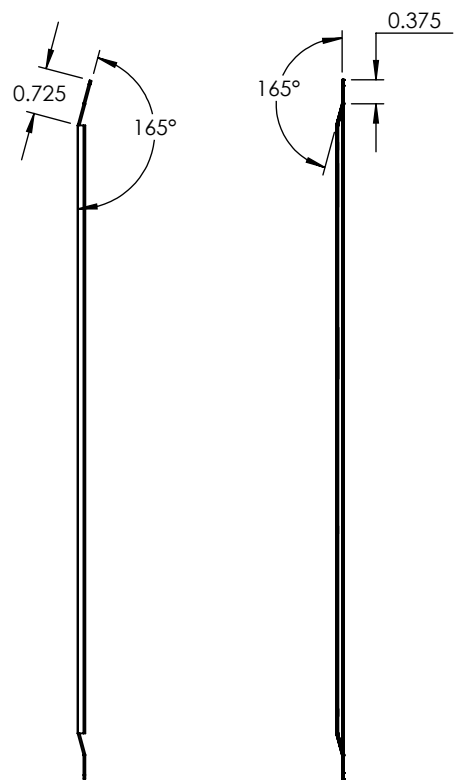
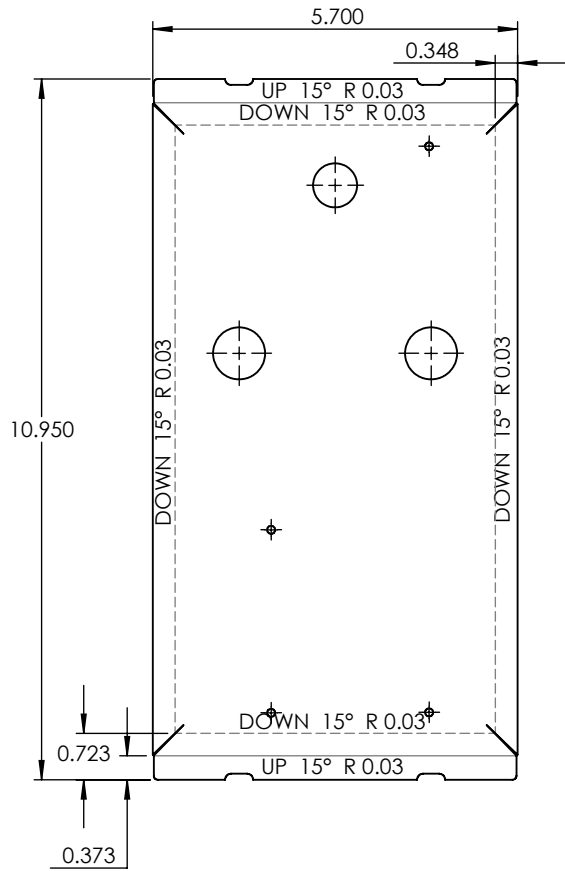

PROPRIETARY AND CONFIDENTIAL
 THE INFORMATION CONTAINED IN THIS DRAWING IS THE SOLE PROPERTY OF <INSERT COMPANY NAME HERE>. ANY REPRODUCTION IN PART OR AS A WHOLE WITHOUT THE WRITTEN PERMISSION OF <INSERT COMPANY NAME HERE> IS PROHIBITED.

		UNLESS OTHERWISE SPECIFIED:		NAME	DATE
		DIMENSIONS ARE IN INCHES	DRAWN		
		TOLERANCES:	CHECKED		
		FRACTIONAL ±	ENG APPR.		
		ANGULAR: MACH ± BEND ±	MFG APPR.		
		TWO PLACE DECIMAL ±	Q.A.		
		THREE PLACE DECIMAL ±	COMMENTS:		
		INTERPRET GEOMETRIC TOLERANCING PER:			
		MATERIAL			
NEXT ASSY	USED ON	FINISH			
APPLICATION		DO NOT SCALE DRAWING			

22 GAUGE		
TITLE:		
COZ2110L-AB-A-PC-41K		
SIZE	DWG. NO.	REV
A		
SCALE: 1:3	WEIGHT:	SHEET 12 OF 15

5

4

3

2

1

ITEM NO.	PART NUMBER	DESCRIPTION	QTY.
1	COZ2114I-MBK-WF-35K-TOP SPUN CAP	SPUN 22 GAUGE	1

ITEM NO.	PART NUMBER	DESCRIPTION	QTY.
1	COZ2110L-AB-A-PC-41K-TOP SPUN CUP	SPUN ALUMINUM 0.0635"	1

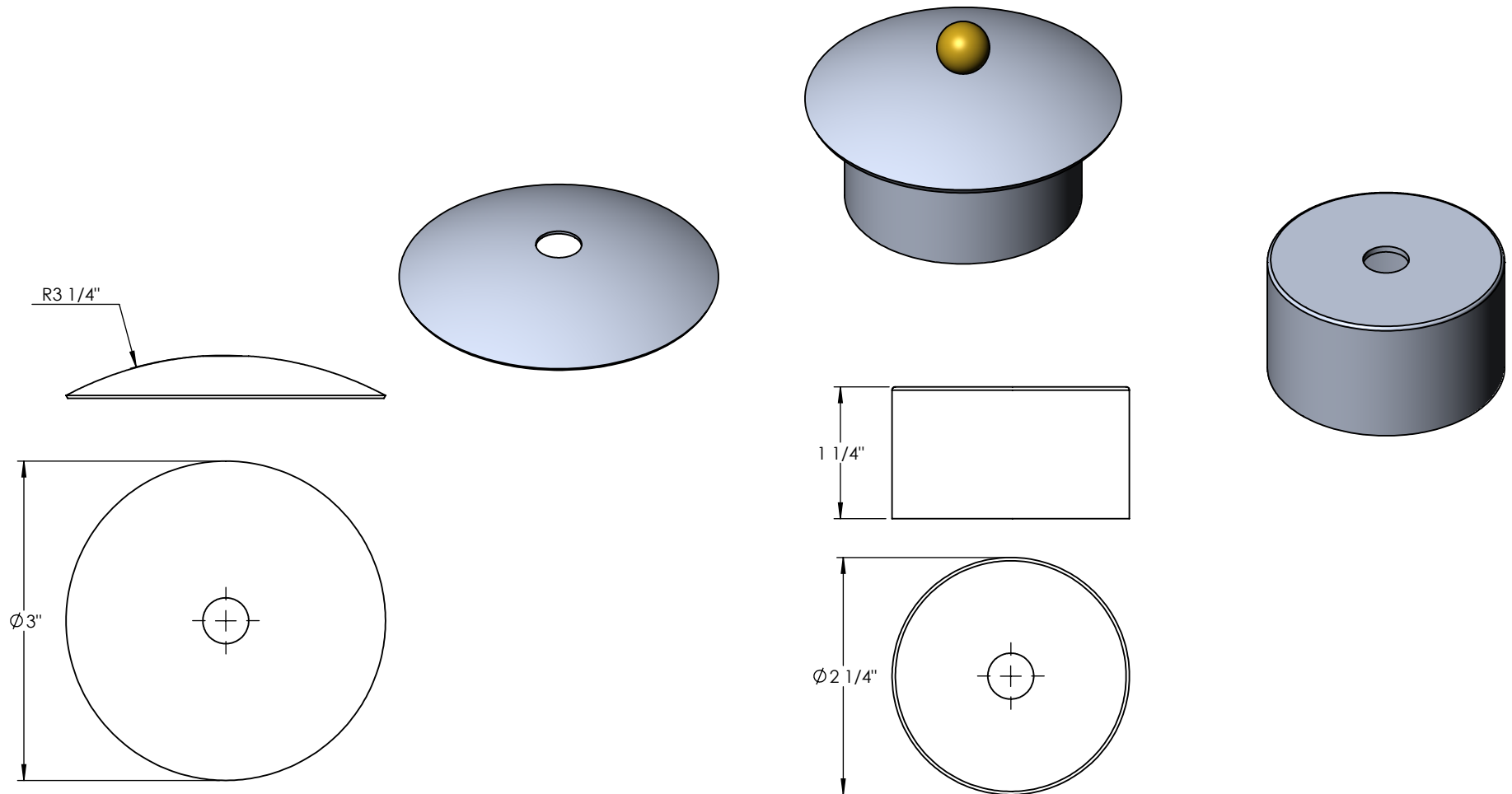

PROPRIETARY AND CONFIDENTIAL
 THE INFORMATION CONTAINED IN THIS DRAWING IS THE SOLE PROPERTY OF <INSERT COMPANY NAME HERE>. ANY REPRODUCTION IN PART OR AS A WHOLE WITHOUT THE WRITTEN PERMISSION OF <INSERT COMPANY NAME HERE> IS PROHIBITED.

		UNLESS OTHERWISE SPECIFIED:		NAME	DATE
		DIMENSIONS ARE IN INCHES		DRAWN	
		TOLERANCES:		CHECKED	
		FRACTIONAL ±		ENG APPR.	
		ANGULAR: MACH ± BEND ±		MFG APPR.	
		TWO PLACE DECIMAL ±		Q.A.	
		THREE PLACE DECIMAL ±		COMMENTS:	
		INTERPRET GEOMETRIC TOLERANCING PER:			
		MATERIAL			
		FINISH			
NEXT ASSY	USED ON				
APPLICATION		DO NOT SCALE DRAWING			

SPUN ALUMINUM 0.0635"		
TITLE:		
COZ2110L-AB-A-PC-41K		
SIZE	DWG. NO.	REV
A		
SCALE: 1:1.5WEIGHT:		SHEET 13 OF 15

5

4

3

2

1

