

ITEM NO.	PART NUMBER	DESCRIPTION	QTY.	CUT
1	BX-SDOF-GRV-DN-5X5-9W-MG-CFA-40K-FRAME	ALUMINUM 0.0635"	1	
2	BX-SDOF-GRV-DN-5X5-9W-MG-CFA-40K-FRAME STRAP	ALUMINUM 0.0635"	2	
3	BX-SDOF-GRV-DN-5X5-9W-MG-CFA-40K-FRAME BACK	ALUMINUM 0.0635"	1	
4	BX-SDOF-GRV-DN-5X5-9W-MG-CFA-40K-FRAME PLATE	ALUMINUM 0.0635"	1	
5	BX-SDOF-GRV-DN-5X5-9W-MG-CFA-40K-LED BRACKET	ALUMINUM 0.0635"	1	
6	BX-SDOF-GRV-DN-5X5-9W-MG-CFA-40K-BACKPLATE	ALUMINUM 0.0635"	1	
7	BX-SDOF-GRV-DN-5X5-9W-MG-CFA-40K-FIREPLATE	ALUMINUM 0.0635"	1	
8	BX-SDOF-GRV-DN-5X5-9W-MG-CFA-40K-BACKPLATE TAB	25 GAUGE ALUMINUM	4	
9	BX-SDOF-GRV-DN-5X5-9W-MG-CFA-40K-SIDE TAB	25 GAUGE ALUMINUM	4	
10	BX-SDOF-GRV-DN-5X5-9W-MG-CFA-40K-ACRYLIC	ACRYLIC	1	
11	Altal_LED_PN1019_SHIM PLATE	ALUMINUM 0.125" PLATE	1	
12	DS-15W-350C1542010-3001	DRIVER	1	
13	Altal_LED_PN1019_RevC	LED	1	

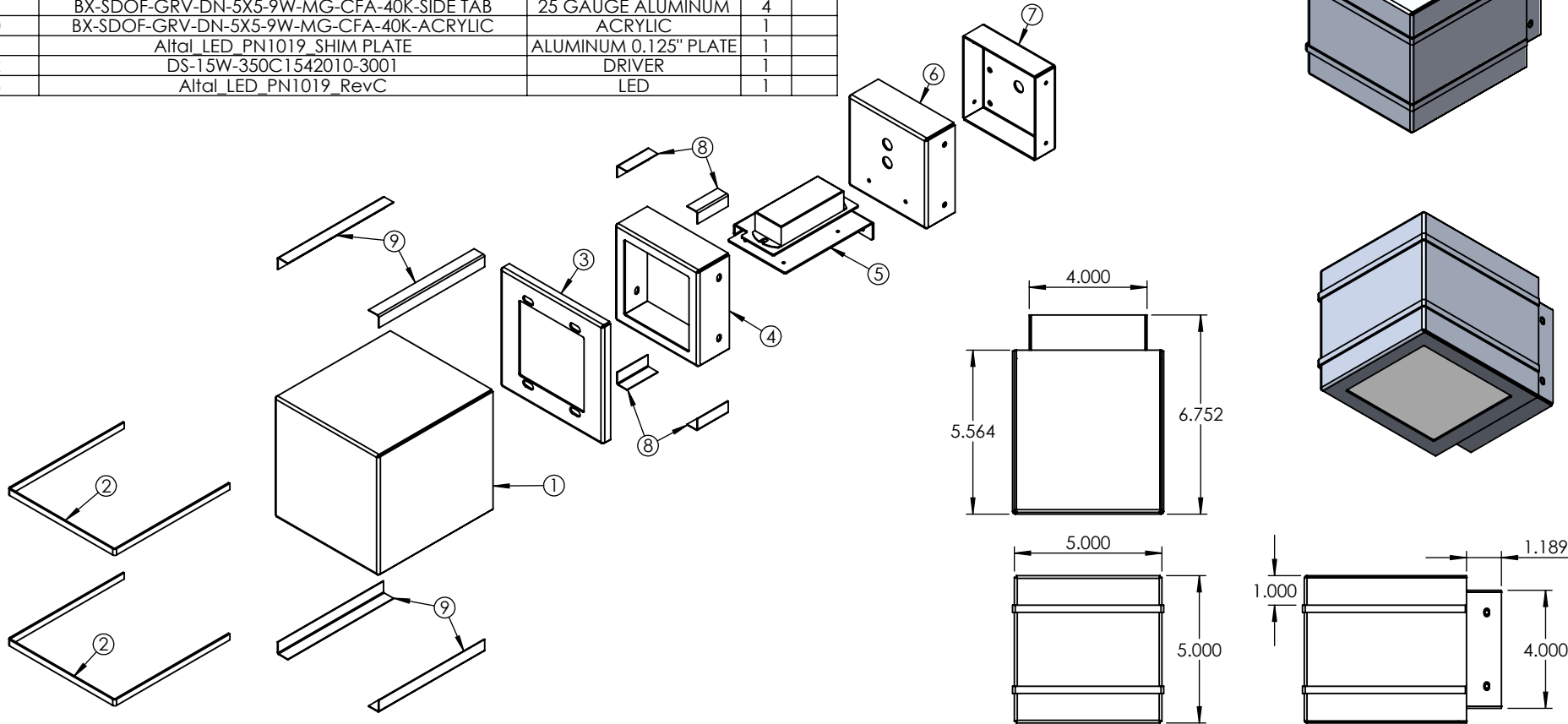

ALL BEND RADIUS .030"

UNLESS OTHERWISE SPECIFIED:
 DIMENSIONS ARE IN INCHES
 TOLERANCES:
 FRACTIONAL ± .003
 ANGULAR: MACH ± .01 BEND ±
 TWO PLACE DECIMAL ±
 THREE PLACE DECIMAL ±.001
 INTERPRET GEOMETRIC
 TOLERANCING PER:
 MATERIAL
 FINISH
 APPLICATION
 DO NOT SCALE DRAWING

NAME	DATE
DRAWN	
CHECKED	
ENG APPR.	
MFG APPR.	
Q.A.	
COMMENTS:	

TITLE: BX-SDOF-GRV-DN-5X5-9W-MG-CFA-40K		
SIZE	DWG. NO.	REV
A	TICKET 27004	
SCALE: 1:5.5	WEIGHT:	SHEET 1 OF 7

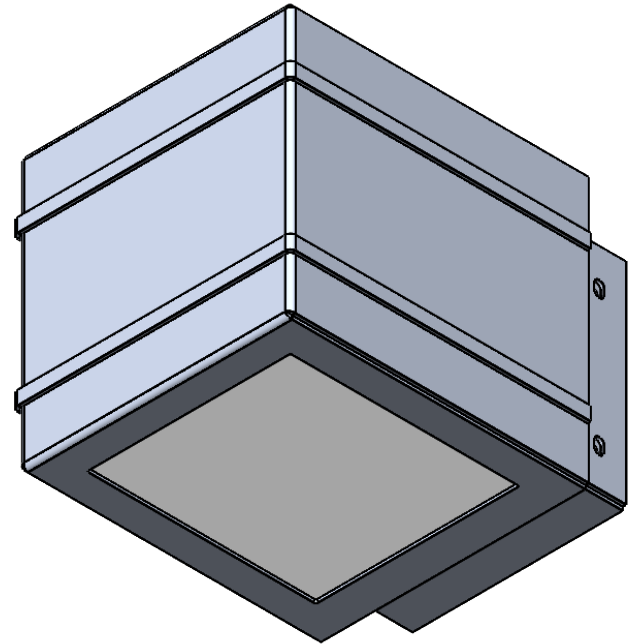
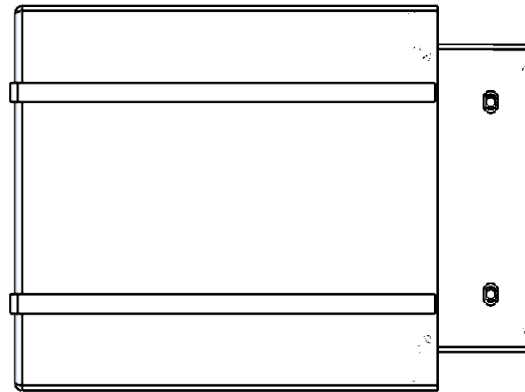
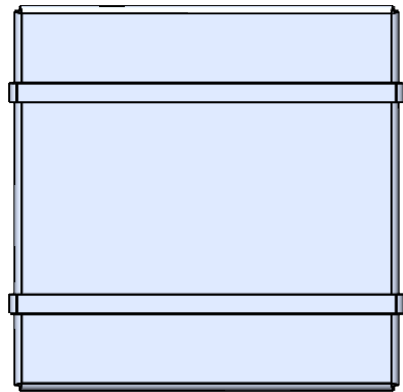
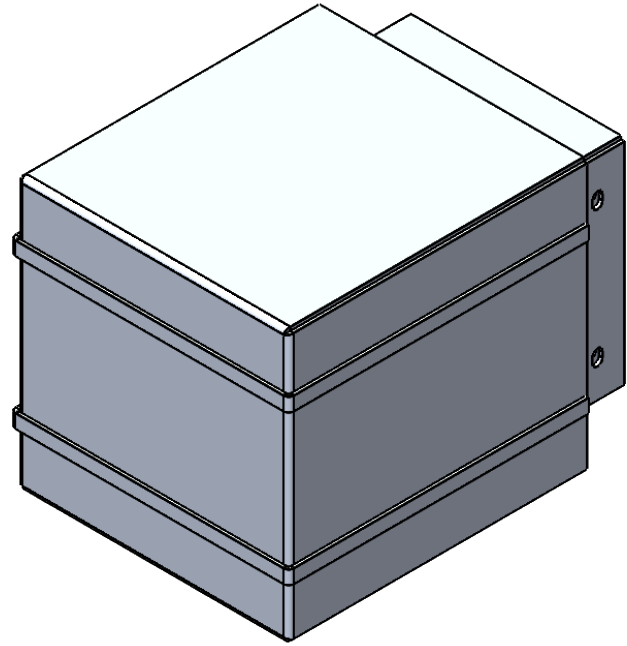
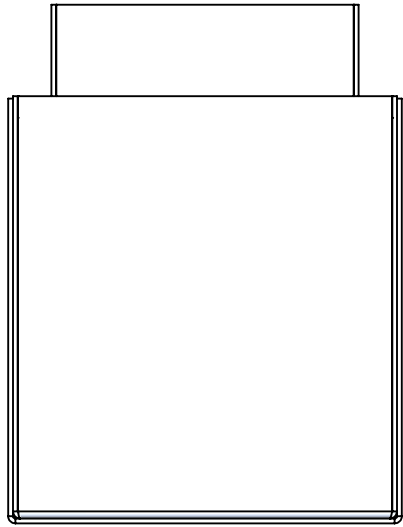

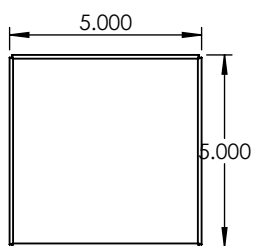
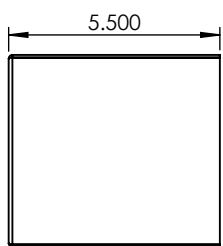
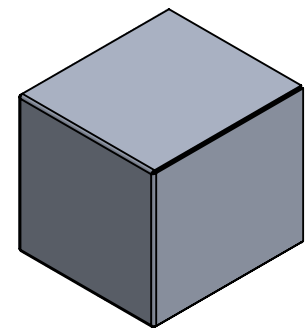
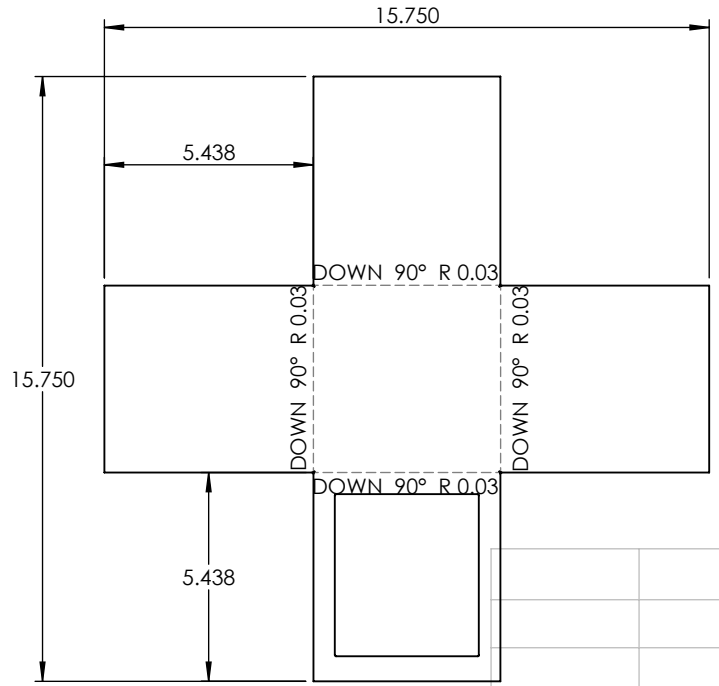
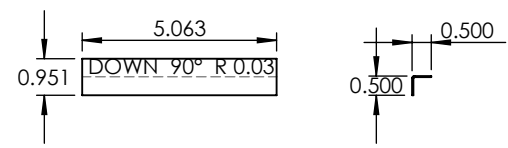
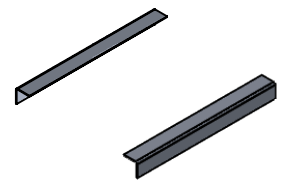
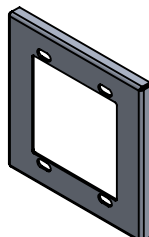
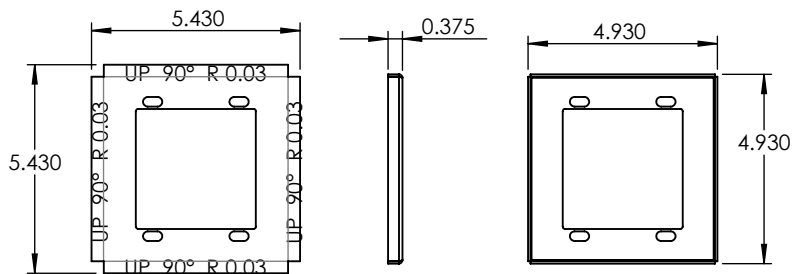

PROPRIETARY AND CONFIDENTIAL
 THE INFORMATION CONTAINED IN THIS DRAWING IS THE SOLE PROPERTY OF <INSERT COMPANY NAME HERE>. ANY REPRODUCTION IN PART OR AS A WHOLE WITHOUT THE WRITTEN PERMISSION OF <INSERT COMPANY NAME HERE> IS PROHIBITED.

		UNLESS OTHERWISE SPECIFIED:	NAME	DATE
		DIMENSIONS ARE IN INCHES	DRAWN	
		TOLERANCES:	CHECKED	
		FRACTIONAL ±	ENG APPR.	
		ANGULAR: MACH ± BEND ±	MFG APPR.	
		TWO PLACE DECIMAL ±	Q.A.	
		THREE PLACE DECIMAL ±	COMMENTS:	
		INTERPRET GEOMETRIC TOLERANCING PER:		
		MATERIAL		
		FINISH		
NEXT ASSY	USED ON			
APPLICATION		DO NOT SCALE DRAWING		

ALUMINUM 0.0635"		
TITLE:		
BX-SDOF-GRV-DN-5X5-9W-MG-CFA-40K		
SIZE	DWG. NO.	REV
A		
SCALE: 1:5	WEIGHT:	SHEET 3 OF 7

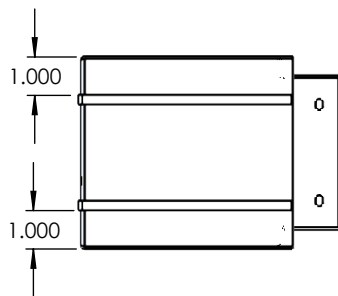
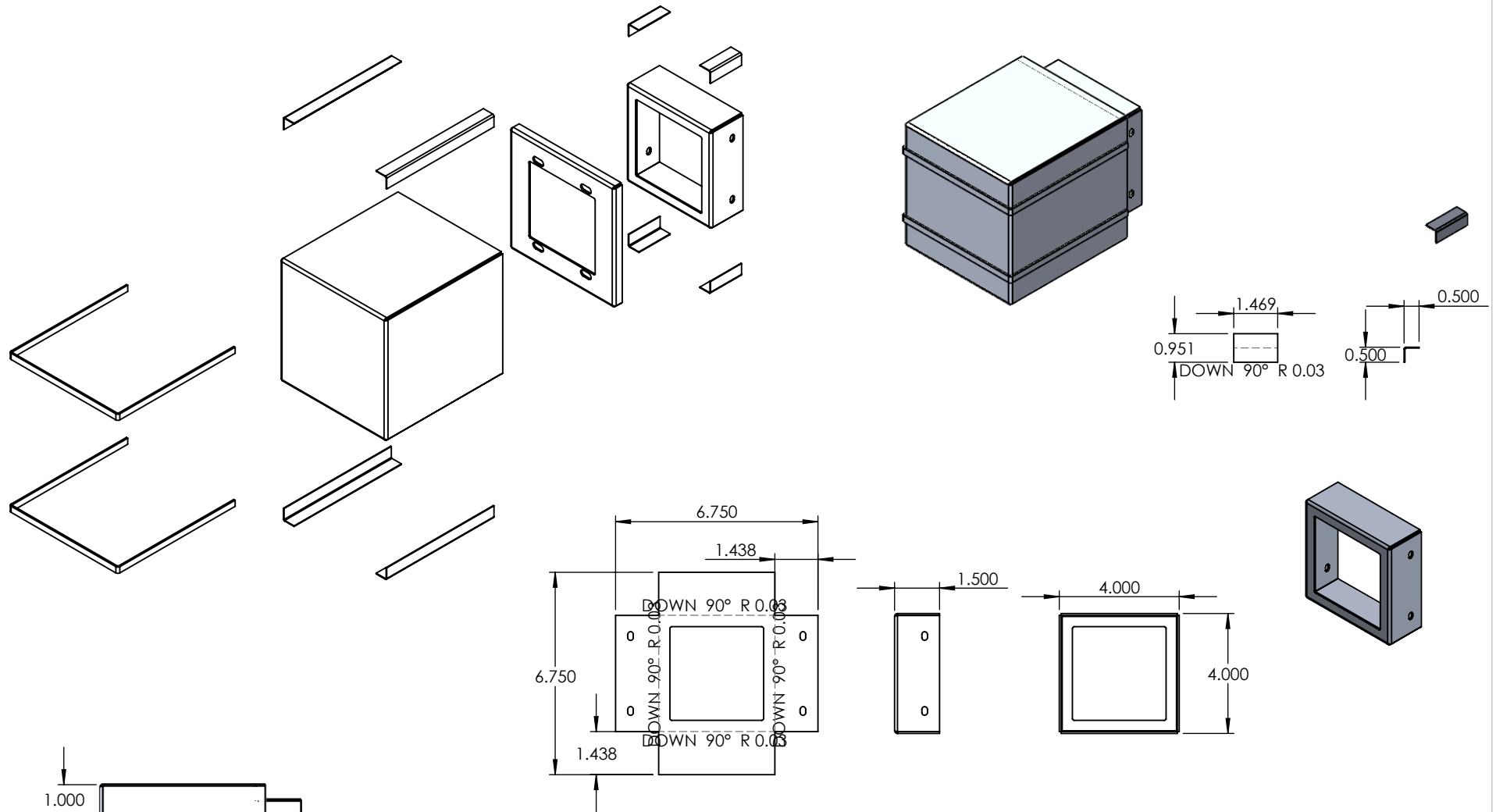

PROPRIETARY AND CONFIDENTIAL
 THE INFORMATION CONTAINED IN THIS DRAWING IS THE SOLE PROPERTY OF <INSERT COMPANY NAME HERE>. ANY REPRODUCTION IN PART OR AS A WHOLE WITHOUT THE WRITTEN PERMISSION OF <INSERT COMPANY NAME HERE> IS PROHIBITED.

		UNLESS OTHERWISE SPECIFIED:	NAME	DATE	ALUMINUM 0.0635"	
		DIMENSIONS ARE IN INCHES TOLERANCES: FRACTIONAL ± ANGULAR: MACH ± BEND ± TWO PLACE DECIMAL ± THREE PLACE DECIMAL ±	DRAWN		TITLE:	
		INTERPRET GEOMETRIC TOLERANCING PER:	CHECKED		BX-SDOF-GRV-DN-5X5-9W-MG-CFA-40K	
		MATERIAL	ENG APPR.		SIZE	DWG. NO.
		FINISH	MFG APPR.		A	REV
NEXT ASSY	USED ON		Q.A.		SCALE: 1:5 WEIGHT: SHEET 4 OF 7	
APPLICATION		DO NOT SCALE DRAWING	COMMENTS:			

5

4

3

2

1

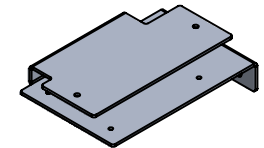
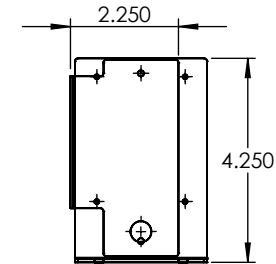
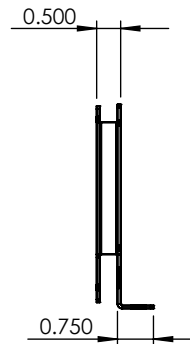
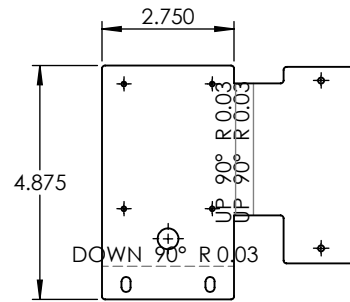
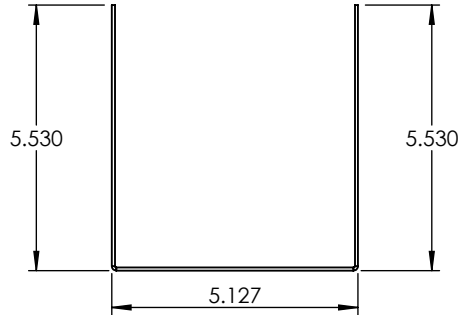
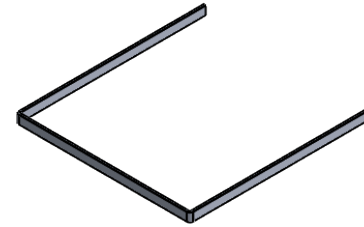
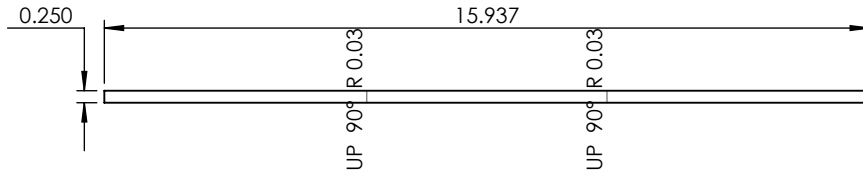

PROPRIETARY AND CONFIDENTIAL
 THE INFORMATION CONTAINED IN THIS DRAWING IS THE SOLE PROPERTY OF <INSERT COMPANY NAME HERE>. ANY REPRODUCTION IN PART OR AS A WHOLE WITHOUT THE WRITTEN PERMISSION OF <INSERT COMPANY NAME HERE> IS PROHIBITED.

		UNLESS OTHERWISE SPECIFIED:		NAME	DATE	ALUMINUM 0.0635"	
		DIMENSIONS ARE IN INCHES		DRAWN		TITLE:	
		TOLERANCES:		CHECKED		BX-SDOF-GRV-DN-5X5-9W-MG-CFA-40K	
		FRACTIONAL ±		ENG APPR.		SIZE DWG. NO. REV	
		ANGULAR: MACH ± BEND ±		MFG APPR.		A	
		TWO PLACE DECIMAL ±		Q.A.		SCALE: 1:4 WEIGHT: SHEET 5 OF 7	
		THREE PLACE DECIMAL ±		COMMENTS:			
		INTERPRET GEOMETRIC TOLERANCING PER:					
		MATERIAL					
	NEXT ASSY	USED ON					
		FINISH					
	APPLICATION	DO NOT SCALE DRAWING					

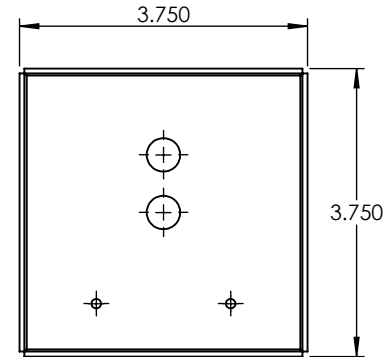
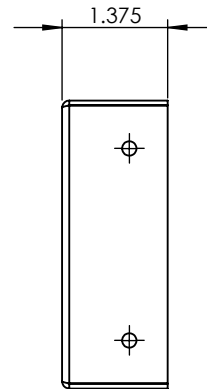
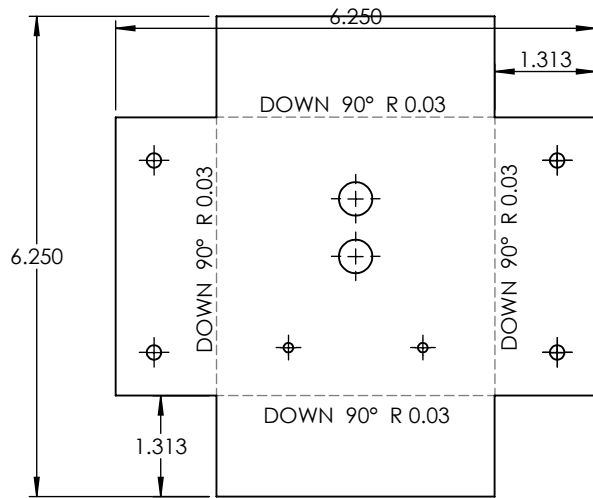
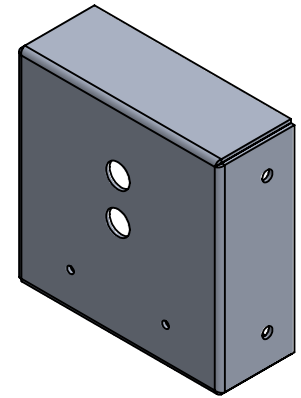

PROPRIETARY AND CONFIDENTIAL
 THE INFORMATION CONTAINED IN THIS DRAWING IS THE SOLE PROPERTY OF <INSERT COMPANY NAME HERE>. ANY REPRODUCTION IN PART OR AS A WHOLE WITHOUT THE WRITTEN PERMISSION OF <INSERT COMPANY NAME HERE> IS PROHIBITED.

		UNLESS OTHERWISE SPECIFIED:		NAME	DATE	ALUMINUM 0.0635"	
		DIMENSIONS ARE IN INCHES		DRAWN		TITLE:	
		TOLERANCES:		CHECKED		BX-SDOF-GRV-DN-5X5-9W-MG-CFA-40K	
		FRACTIONAL ±		ENG APPR.		SIZE	DWG. NO.
		ANGULAR: MACH ± BEND ±		MFG APPR.		A	REV
		TWO PLACE DECIMAL ±		Q.A.		SCALE: 1:2.5WEIGHT:	
		THREE PLACE DECIMAL ±		COMMENTS:		SHEET 6 OF 7	
		INTERPRET GEOMETRIC TOLERANCING PER:					
		MATERIAL					
	NEXT ASSY	FINISH					
		USED ON					
	APPLICATION	DO NOT SCALE DRAWING					

5

4

3

2

1

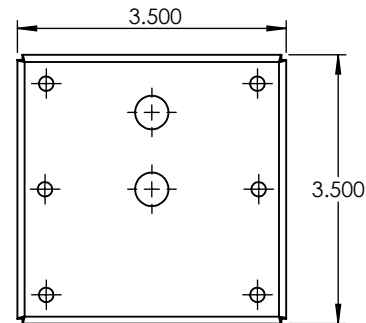
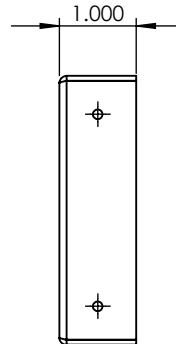
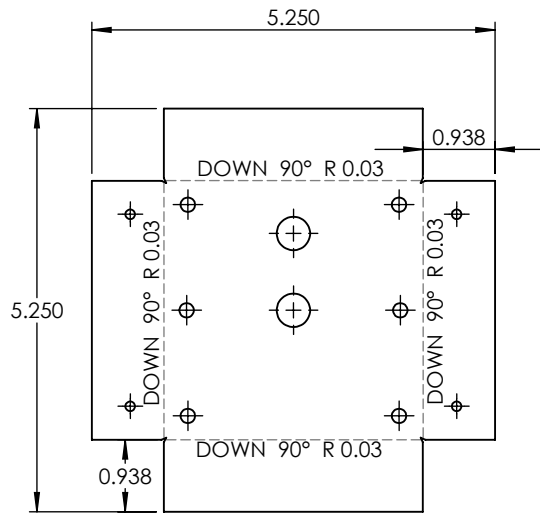
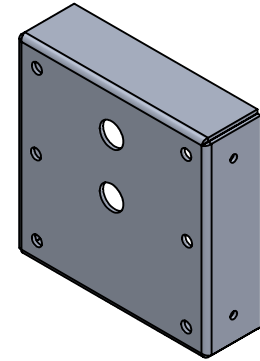

PROPRIETARY AND CONFIDENTIAL
 THE INFORMATION CONTAINED IN THIS DRAWING IS THE SOLE PROPERTY OF <INSERT COMPANY NAME HERE>. ANY REPRODUCTION IN PART OR AS A WHOLE WITHOUT THE WRITTEN PERMISSION OF <INSERT COMPANY NAME HERE> IS PROHIBITED.

		UNLESS OTHERWISE SPECIFIED:		NAME	DATE	ALUMINUM 0.0635"		
		DIMENSIONS ARE IN INCHES TOLERANCES: FRACTIONAL ± ANGULAR: MACH ± BEND ± TWO PLACE DECIMAL ± THREE PLACE DECIMAL ±	DRAWN					TITLE:
		INTERPRET GEOMETRIC TOLERANCING PER:	CHECKED			BX-SDOF-GRV-DN-5X5-9W-MG-CFA-40K		
		MATERIAL	ENG APPR.					
		FINISH	MFG APPR.			SIZE	DWG. NO.	REV
NEXT ASSY	USED ON		Q.A.			A		
APPLICATION		DO NOT SCALE DRAWING	COMMENTS:				SCALE: 1:2.5	WEIGHT:

5

4

3

2

1