

| ITEM NO. | PART NUMBER | DESCRIPTION | QTY. |
|----------|---|------------------|------|
| 1 | 901-MOD-20"-15W-TBK-WF-STBL-DIM-WET-35K-FRAME | ALUMINUM 0.0635" | 1 |
| 2 | 901-MOD-20"-15W-TBK-WF-STBL-DIM-WET-35K-LED SPACER | 22 GAUGE | 1 |
| 3 | 901-MOD-20"-15W-TBK-WF-STBL-DIM-WET-35K-BACKPLATE | 22 GAUGE | 1 |
| 4 | 901-MOD-20"-15W-TBK-WF-STBL-DIM-WET-35K-FIREPLATE | 22 GAUGE | 1 |
| 5 | 901-MOD-20"-15W-TBK-WF-STBL-DIM-WET-35K-FRONT FRAME | ALUMINUM 0.0635" | 1 |
| 6 | 901-MOD-20"-15W-TBK-WF-STBL-DIM-WET-35K-SIDE FRAME | ALUMINUM 0.0635" | 2 |
| 7 | 901-MOD-20"-15W-TBK-WF-STBL-DIM-WET-35K-HEAD BASE | ALUMINUM 0.0635" | 1 |
| 8 | 901-MOD-20"-15W-TBK-WF-STBL-DIM-WET-35K-BOTTOM BASE | ALUMINUM 0.0635" | 1 |
| 9 | 901-MOD-20"-15W-TBK-WF-STBL-DIM-WET-35K-SPACER TAB | 25 GAUGE | 4 |
| 10 | 901-MOD-20"-15W-TBK-WF-STBL-DIM-WET-35K-ACRYLIC | ACRYLIC | 1 |
| 11 | KTLD-25-UV-700-VDIM-LA1 | DRIVER | 1 |
| 12 | AlfaLED_PN1004RevD | LED | 2 |

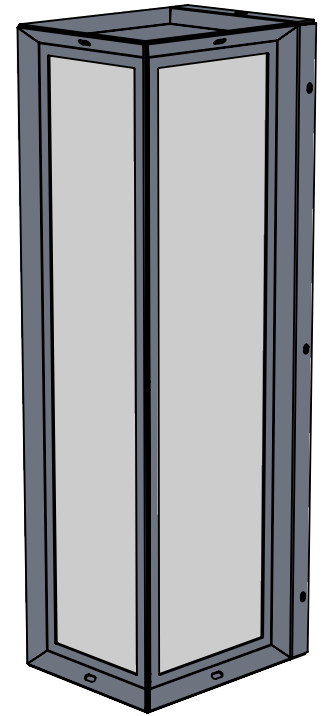
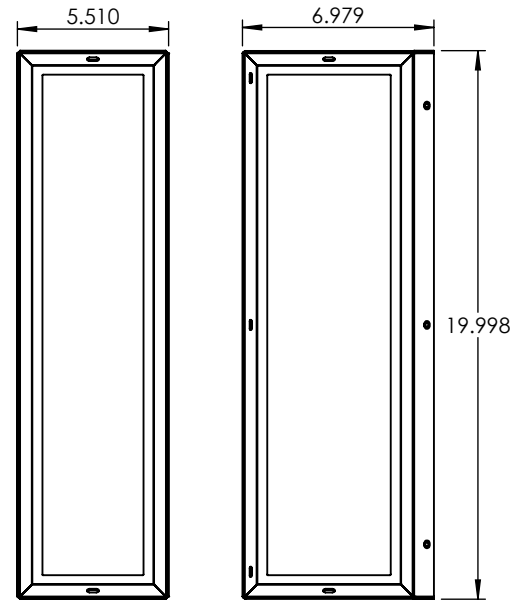
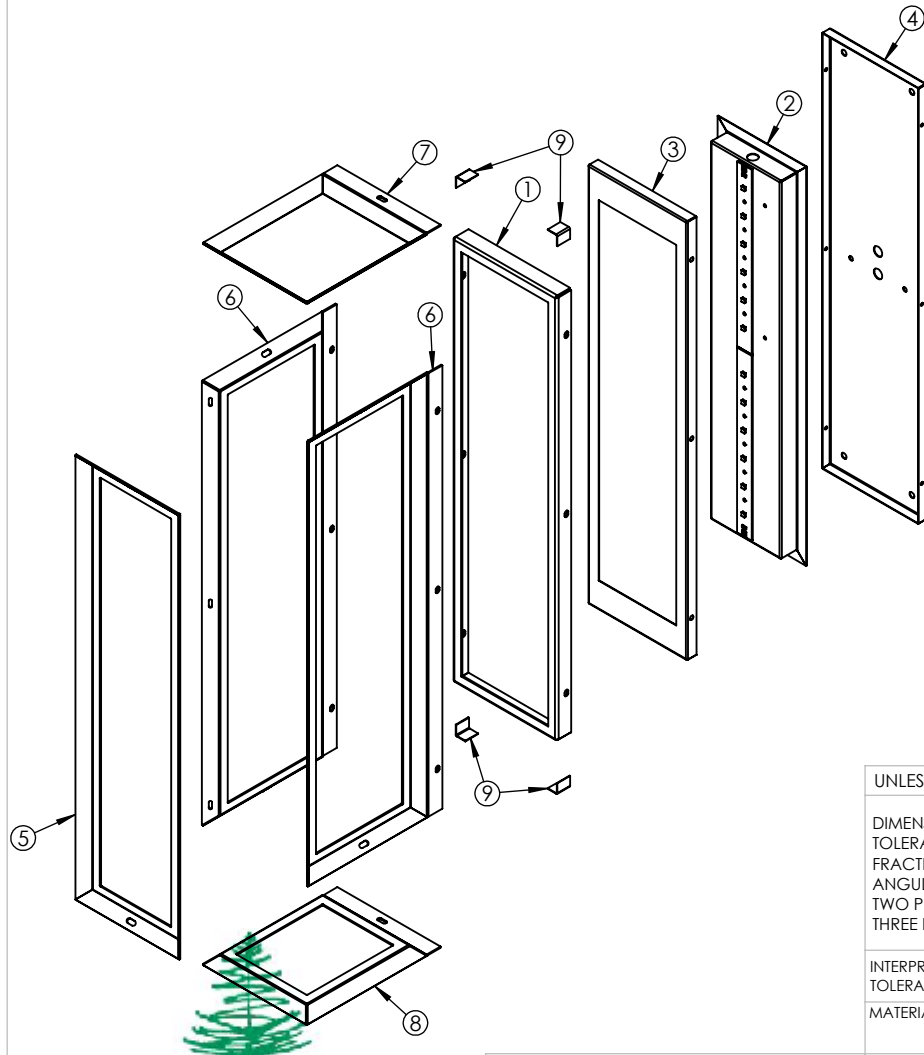

EVERGREEN LIGHTING

ALL BEND RADIUS .030"

APPLICATION

DO NOT SCALE DRAWING

UNLESS OTHERWISE SPECIFIED:

DIMENSIONS ARE IN INCHES
TOLERANCES:
FRACTIONAL ± .003
ANGULAR: MACH ± .01 BEND ±
TWO PLACE DECIMAL ±
THREE PLACE DECIMAL ±.001

INTERPRET GEOMETRIC
TOLERANCING PER:
MATERIAL

FINISH

NAME DATE

DRAWN
CHECKED
ENG APPR.
MFG APPR.

Q.A.
COMMENTS:

TITLE:

901-MOD-20"-15W-TBK-WF-STBL-DIM-WET-35K

SIZE DWG. NO.

A TICKET 27024

REV

SCALE: 1:7 WEIGHT:

SHEET 1 OF 8

5

4

3

2

1

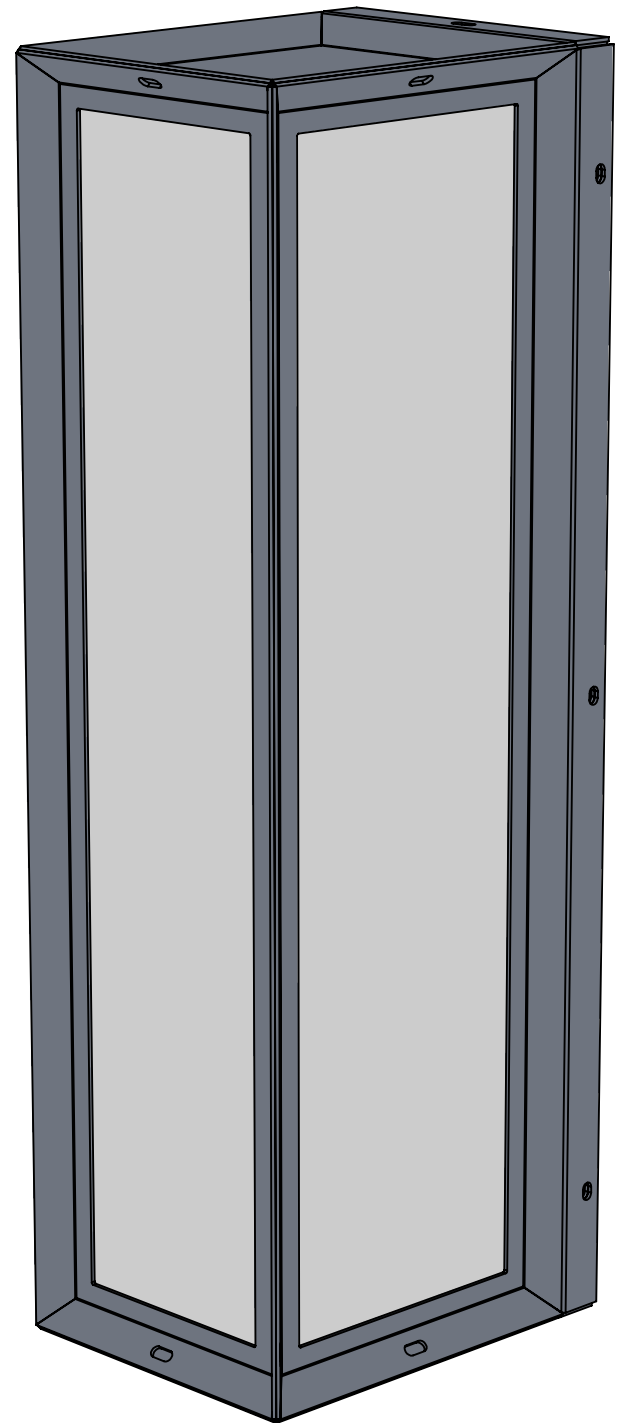
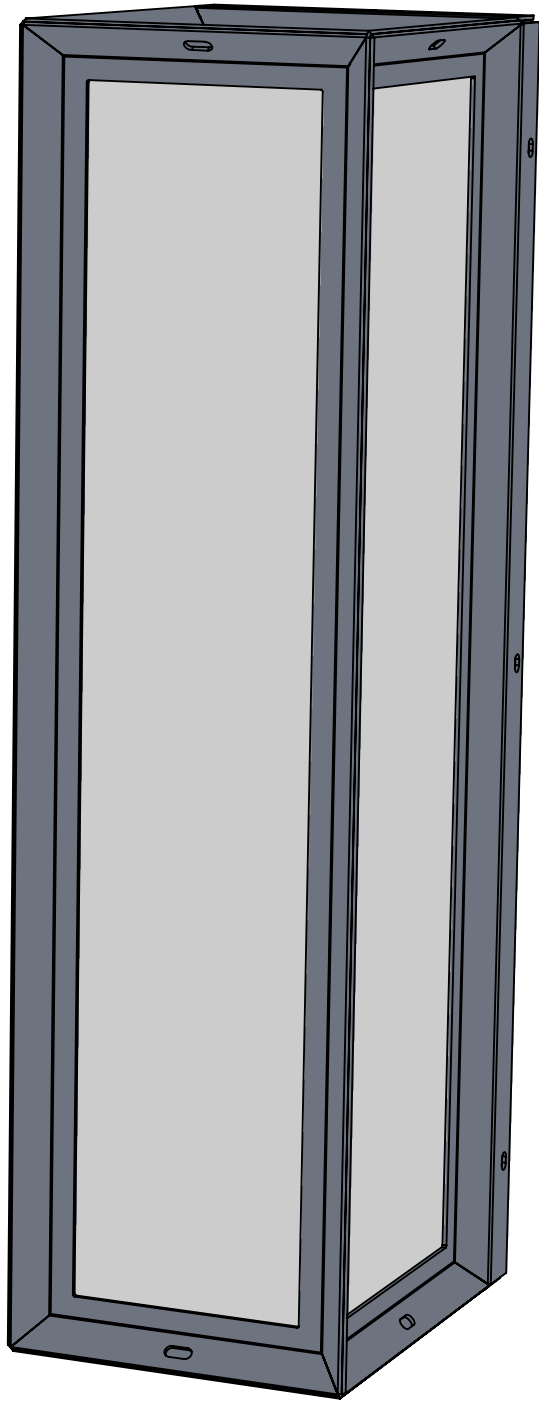

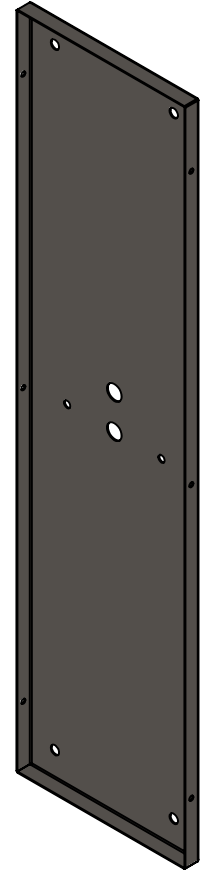
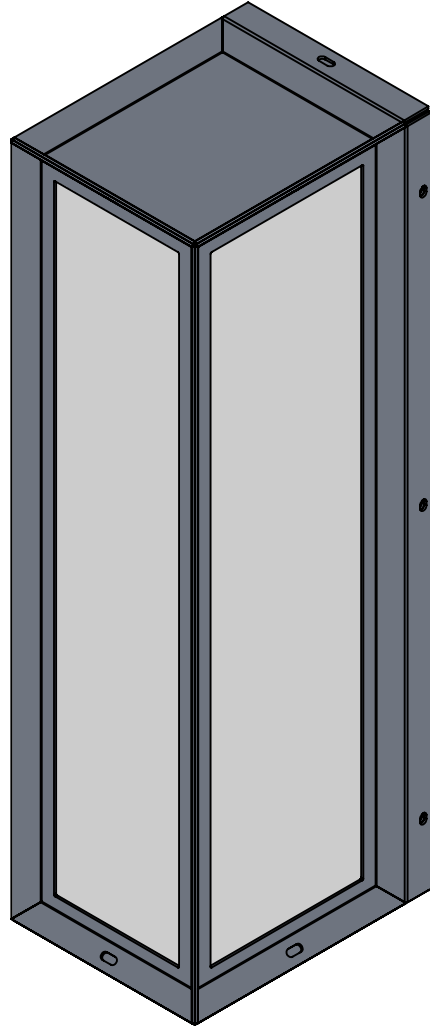
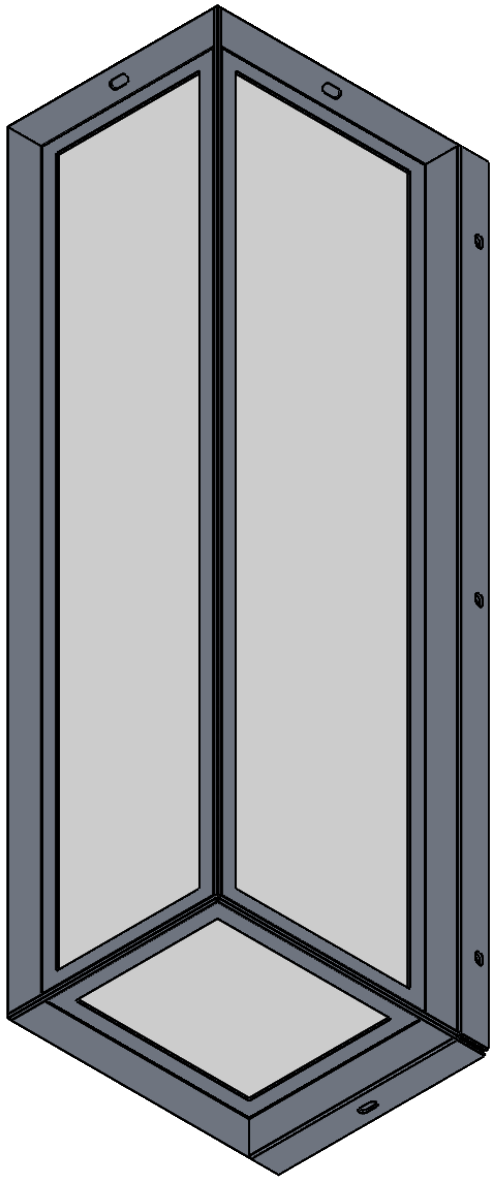

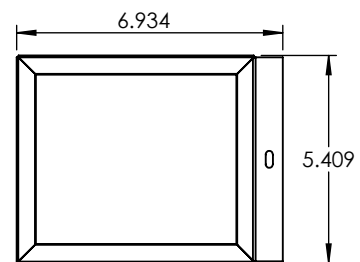
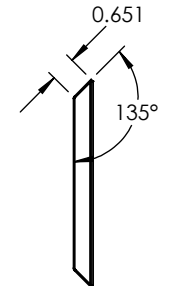
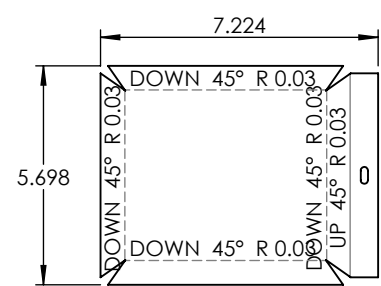
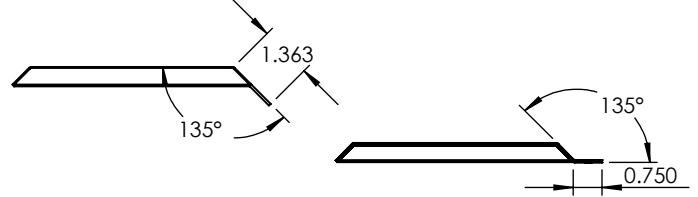
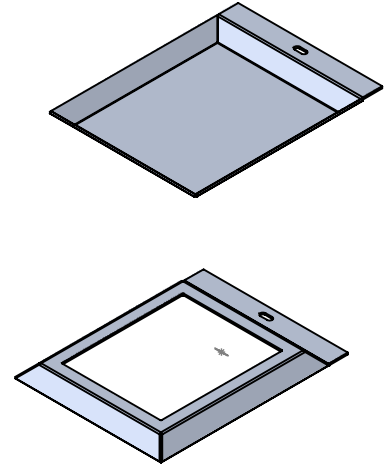
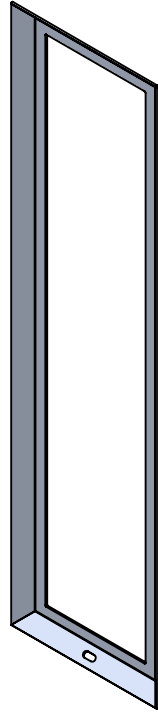
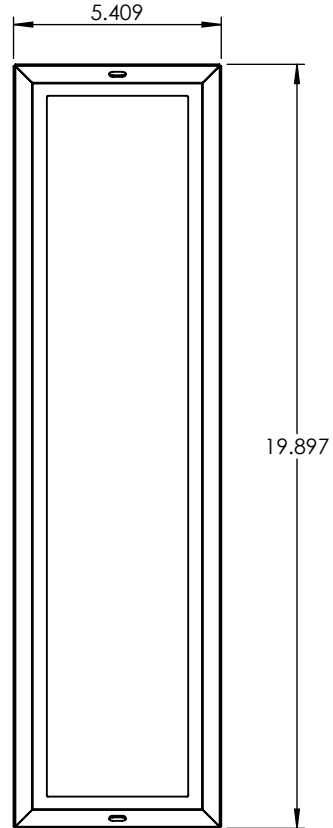
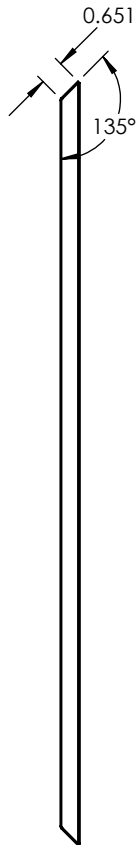
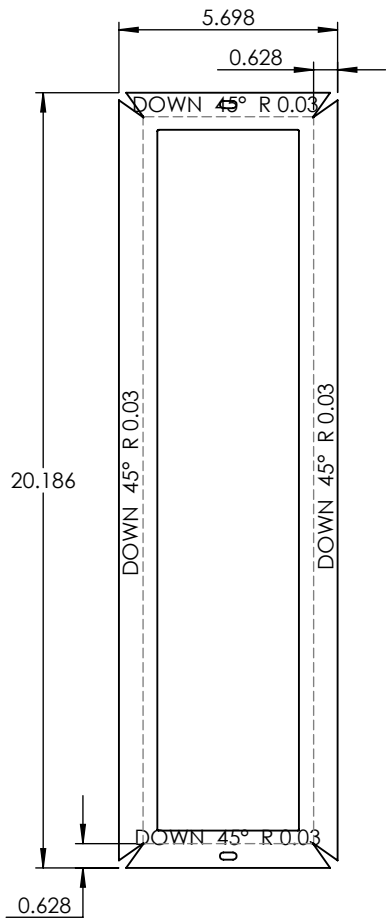

PROPRIETARY AND CONFIDENTIAL
 THE INFORMATION CONTAINED IN THIS DRAWING IS THE SOLE PROPERTY OF <INSERT COMPANY NAME HERE>. ANY REPRODUCTION IN PART OR AS A WHOLE WITHOUT THE WRITTEN PERMISSION OF <INSERT COMPANY NAME HERE> IS PROHIBITED.

| | | | | | |
|-------------|---------|--------------------------------------|-----------|------|------|
| | | UNLESS OTHERWISE SPECIFIED: | | NAME | DATE |
| | | DIMENSIONS ARE IN INCHES | DRAWN | | |
| | | TOLERANCES: | CHECKED | | |
| | | FRACTIONAL ± | ENG APPR. | | |
| | | ANGULAR: MACH ± BEND ± | MFG APPR. | | |
| | | TWO PLACE DECIMAL ± | Q.A. | | |
| | | THREE PLACE DECIMAL ± | COMMENTS: | | |
| | | INTERPRET GEOMETRIC TOLERANCING PER: | | | |
| | | MATERIAL | | | |
| | | FINISH | | | |
| NEXT ASSY | USED ON | | | | |
| APPLICATION | | DO NOT SCALE DRAWING | | | |

| | | |
|---|----------|--------------|
| ALUMINUM 0.0635" | | |
| TITLE: | | |
| 901-MOD-20"-15W-TBK-WF-STBL-DIM-WET-35K | | |
| SIZE | DWG. NO. | REV |
| A | | |
| SCALE: 1:5 | WEIGHT: | SHEET 4 OF 8 |

5

4

3

2

1

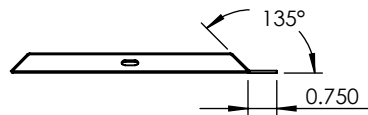
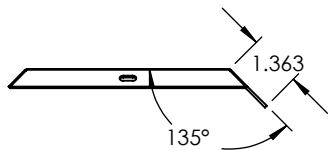
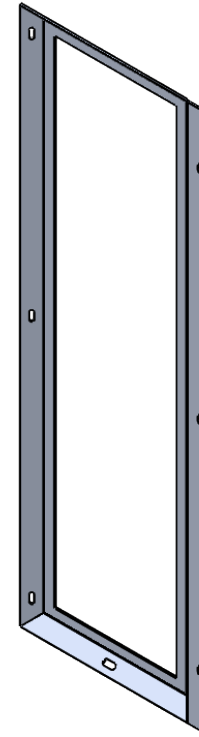
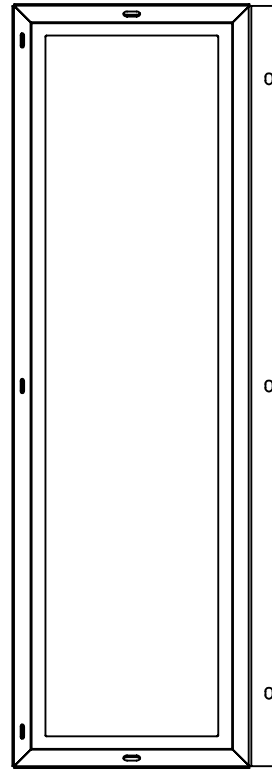
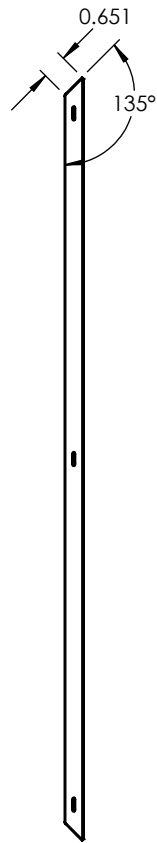
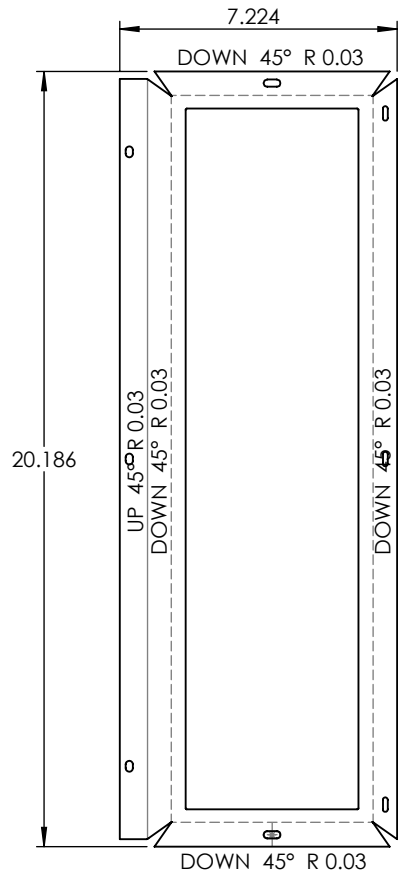

UNLESS OTHERWISE SPECIFIED:

DIMENSIONS ARE IN INCHES
 TOLERANCES:
 FRACTIONAL ±
 ANGULAR: MACH ± BEND ±
 TWO PLACE DECIMAL ±
 THREE PLACE DECIMAL ±

INTERPRET GEOMETRIC
 TOLERANCING PER:

MATERIAL

FINISH

DO NOT SCALE DRAWING

NAME

DATE

ALUMINUM 0.0635"

DRAWN

CHECKED

ENG APPR.

MFG APPR.

Q.A.

COMMENTS:

TITLE:

901-MOD-20"-15W-TBK-WF-STBL-DIM-WET-35K

SIZE
A

DWG. NO.

REV

SCALE: 1:1

WEIGHT:

SHEET 5 OF 8

PROPRIETARY AND CONFIDENTIAL

THE INFORMATION CONTAINED IN THIS DRAWING IS THE SOLE PROPERTY OF <INSERT COMPANY NAME HERE>. ANY REPRODUCTION IN PART OR AS A WHOLE WITHOUT THE WRITTEN PERMISSION OF <INSERT COMPANY NAME HERE> IS PROHIBITED.

| | |
|-------------|---------|
| | |
| NEXT ASSY | USED ON |
| APPLICATION | |

5

4

3

2

1

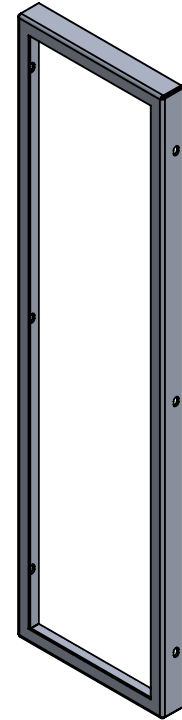
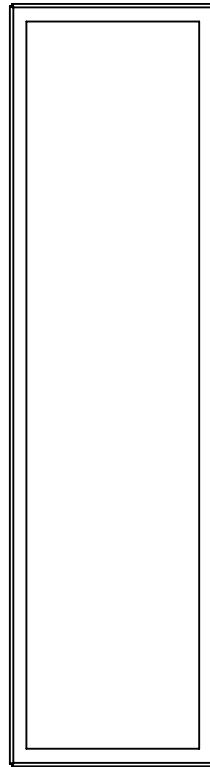
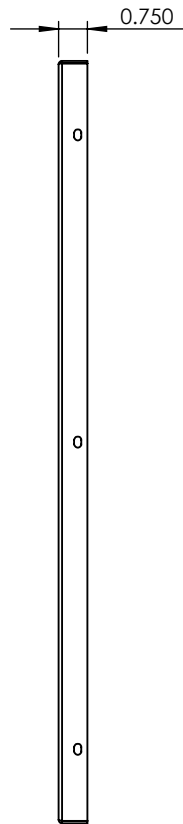
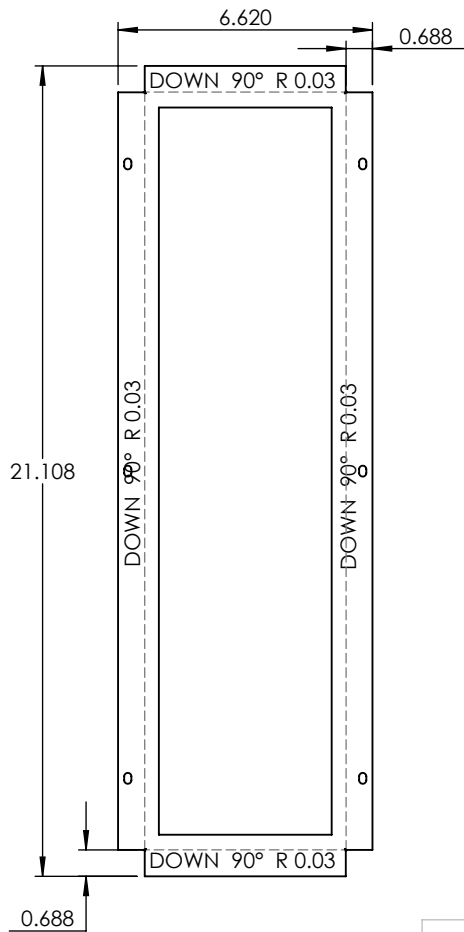

PROPRIETARY AND CONFIDENTIAL
 THE INFORMATION CONTAINED IN THIS DRAWING IS THE SOLE PROPERTY OF <INSERT COMPANY NAME HERE>. ANY REPRODUCTION IN PART OR AS A WHOLE WITHOUT THE WRITTEN PERMISSION OF <INSERT COMPANY NAME HERE> IS PROHIBITED.

| | | | | | | |
|-------------|---------|--------------------------------------|-----------|------|---|--|
| | | UNLESS OTHERWISE SPECIFIED: | NAME | DATE | ALUMINUM 0.0635" | |
| | | DIMENSIONS ARE IN INCHES | DRAWN | | TITLE: | |
| | | TOLERANCES: | CHECKED | | 901-MOD-20"-15W-TBK-WF-STBL-DIM-WET-35K | |
| | | FRACTIONAL ± | ENG APPR. | | SIZE DWG. NO. REV | |
| | | ANGULAR: MACH ± BEND ± | MFG APPR. | | SCALE: 1:5 WEIGHT: SHEET 6 OF 8 | |
| | | TWO PLACE DECIMAL ± | Q.A. | | | |
| | | THREE PLACE DECIMAL ± | COMMENTS: | | | |
| | | INTERPRET GEOMETRIC TOLERANCING PER: | | | | |
| | | MATERIAL | | | | |
| | | FINISH | | | | |
| NEXT ASSY | USED ON | | | | | |
| APPLICATION | | DO NOT SCALE DRAWING | | | | |

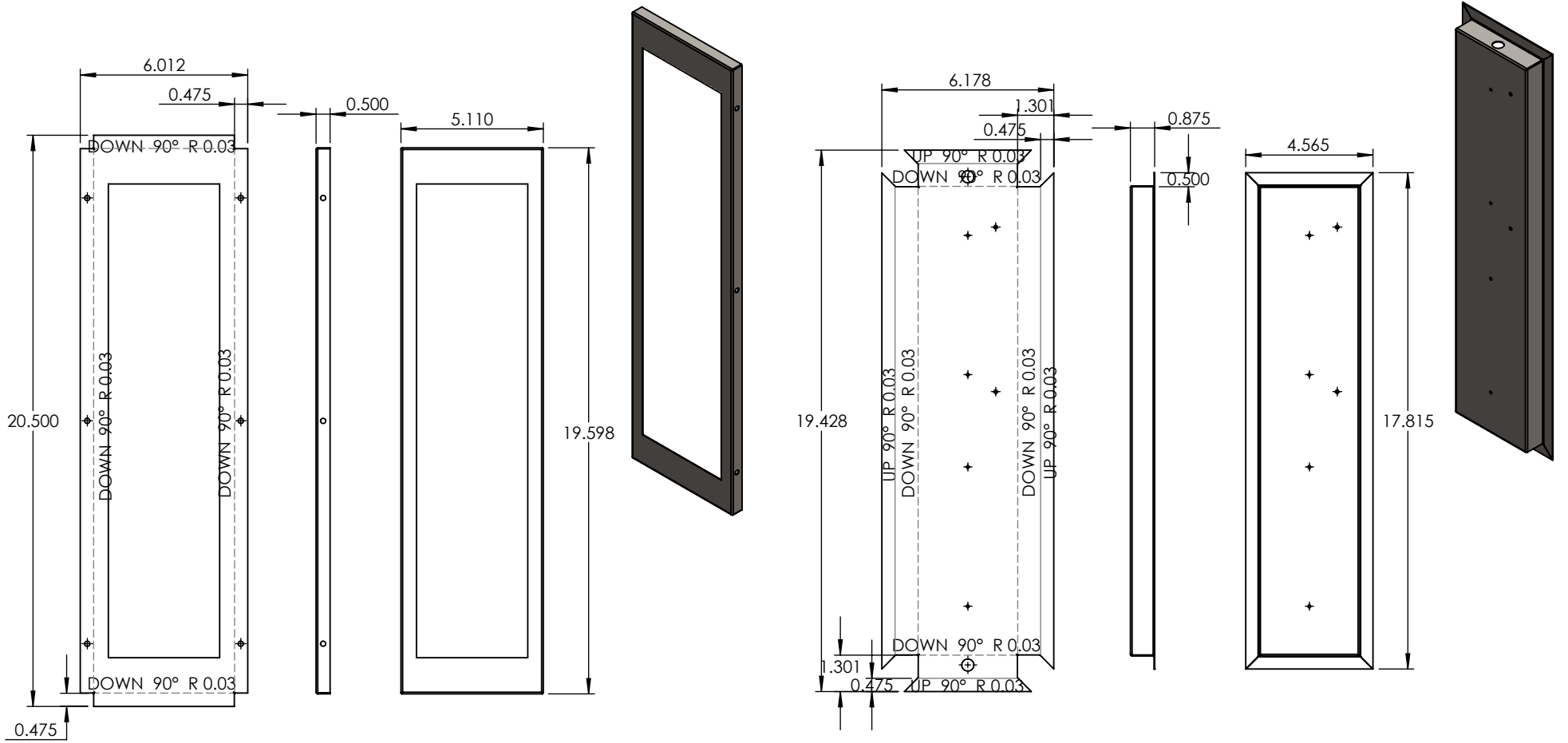

PROPRIETARY AND CONFIDENTIAL
 THE INFORMATION CONTAINED IN THIS DRAWING IS THE SOLE PROPERTY OF <INSERT COMPANY NAME HERE>. ANY REPRODUCTION IN PART OR AS A WHOLE WITHOUT THE WRITTEN PERMISSION OF <INSERT COMPANY NAME HERE> IS PROHIBITED.

| | | | | | |
|-------------|---------|--------------------------------------|-----------|------|------|
| | | UNLESS OTHERWISE SPECIFIED: | | NAME | DATE |
| | | DIMENSIONS ARE IN INCHES | DRAWN | | |
| | | TOLERANCES: | CHECKED | | |
| | | FRACTIONAL ± | ENG APPR. | | |
| | | ANGULAR: MACH ± BEND ± | MFG APPR. | | |
| | | TWO PLACE DECIMAL ± | Q.A. | | |
| | | THREE PLACE DECIMAL ± | COMMENTS: | | |
| | | INTERPRET GEOMETRIC TOLERANCING PER: | | | |
| | | MATERIAL | | | |
| | | FINISH | | | |
| NEXT ASSY | USED ON | | | | |
| APPLICATION | | DO NOT SCALE DRAWING | | | |

| | | |
|--|----------|--------------|
| 22 GAUGE | | |
| TITLE: | | |
| 901-MOD-20"-15W-TBK-WF-STBL-DIM-WET-35K | | |
| SIZE | DWG. NO. | REV |
| A | | |
| SCALE: 1:5.5WEIGHT: | | SHEET 7 OF 8 |

5

4

3

2

1

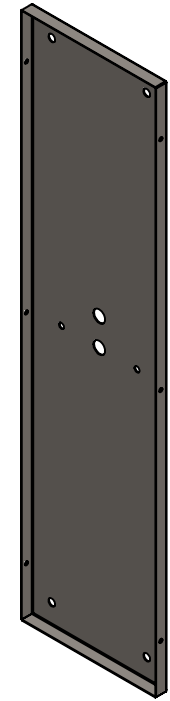
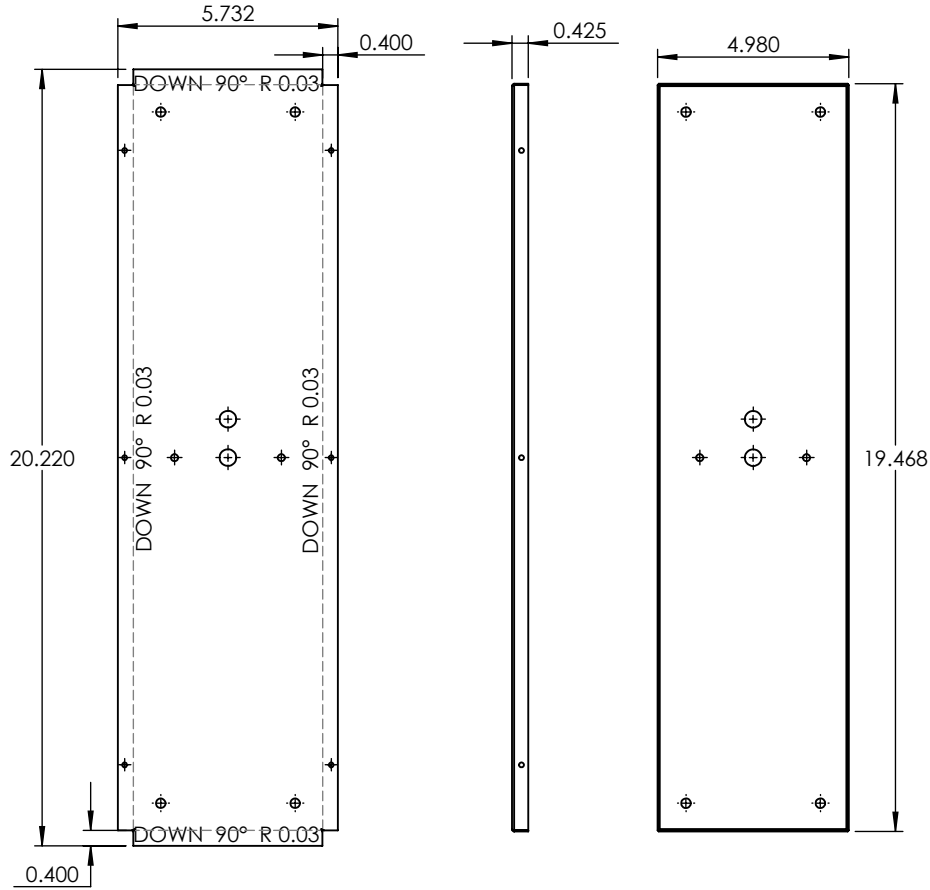

PROPRIETARY AND CONFIDENTIAL
 THE INFORMATION CONTAINED IN THIS DRAWING IS THE SOLE PROPERTY OF <INSERT COMPANY NAME HERE>. ANY REPRODUCTION IN PART OR AS A WHOLE WITHOUT THE WRITTEN PERMISSION OF <INSERT COMPANY NAME HERE> IS PROHIBITED.

| | | | | | | | | |
|-------------|---------|---|-----------|------|------|---|----------|--------------|
| | | UNLESS OTHERWISE SPECIFIED: | | NAME | DATE | 22 GAUGE | | |
| | | DIMENSIONS ARE IN INCHES TOLERANCES: FRACTIONAL ± ANGULAR: MACH ± BEND ± TWO PLACE DECIMAL ± THREE PLACE DECIMAL ± | DRAWN | | | | | TITLE: |
| | | INTERPRET GEOMETRIC TOLERANCING PER: | CHECKED | | | 901-MOD-20"-15W-TBK-WF-STBL-DIM-WET-35K | | |
| | | MATERIAL | ENG APPR. | | | Q.A. | | |
| | | FINISH | MFG APPR. | | | COMMENTS: | | |
| NEXT ASSY | USED ON | | | | | SIZE | DWG. NO. | REV |
| APPLICATION | | DO NOT SCALE DRAWING | | | | A | | |
| | | | | | | SCALE: 1:5 | WEIGHT: | SHEET 8 OF 8 |

5

4

3

2

1