

ITEM NO.	PART NUMBER	DESCRIPTION	QTY.	CUT
1	ASY-SC16-12W-TR-WF-DIM-40K-BACKPLATE	22 GAUGE	1	
2	ASY-SC16-12W-TR-WF-DIM-40K-LED SPACER	22 GAUGE	1	
3	ASY-SC16-12W-TR-WF-DIM-40K-FIREPLATE	22 GAUGE	1	
4	ASY-SC16-12W-TR-WF-DIM-40K-ACRYLIC	ACRYLIC	1	
5	ASY-SC16-12W-TR-WF-DIM-40K-FRONT PLATE	ALUMINUM 0.250" PLATE	1	
6	ASY-SC16-12W-TR-WF-DIM-40K-RIGHT PLATE	ALUMINUM 0.250" PLATE	1	
7	ASY-SC16-12W-TR-WF-DIM-40K-LEFT PLATE	ALUMINUM 0.250" PLATE	1	
8	KTLD-25-UV-700-VDIM-LA1	DRIVER	1	
9	Alttailed_PN1012_RevD	LED	4	

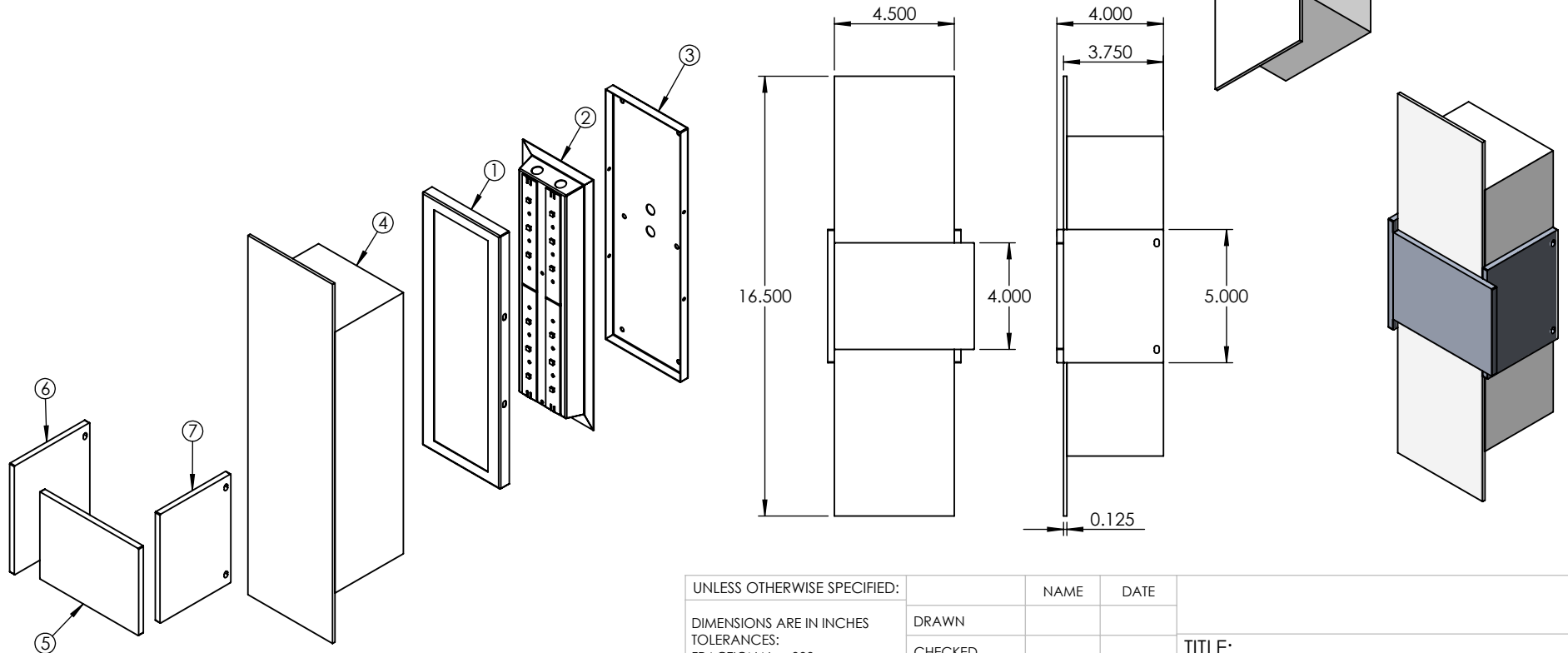

UNLESS OTHERWISE SPECIFIED:		NAME	DATE
DIMENSIONS ARE IN INCHES		DRAWN	
TOLERANCES:		CHECKED	
FRACTIONAL ± .003		ENG APPR.	
ANGULAR: MACH ± .01 BEND ±		MFG APPR.	
TWO PLACE DECIMAL ±		Q.A.	
THREE PLACE DECIMAL ±.001		COMMENTS:	
INTERPRET GEOMETRIC TOLERANCING PER:		TITLE: ASY-SC16-12W-TR-WF-DIM-40K-ASSEMBLY	
MATERIAL			
FINISH		SIZE	DWG. NO.
APPLICATION		A TICKET 27033	
DO NOT SCALE DRAWING		SCALE: 1:6	WEIGHT:
		SHEET 1 OF 7	



5

4

3

2

1

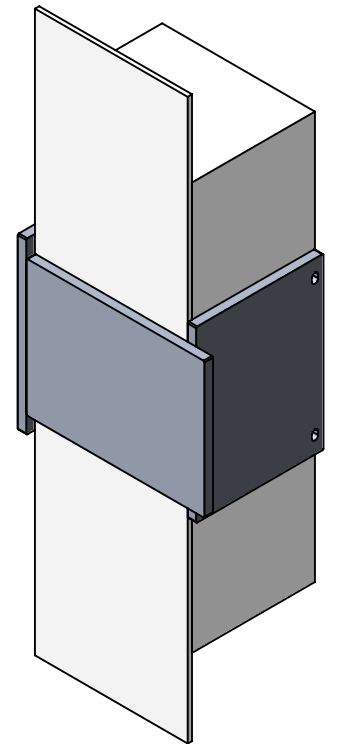
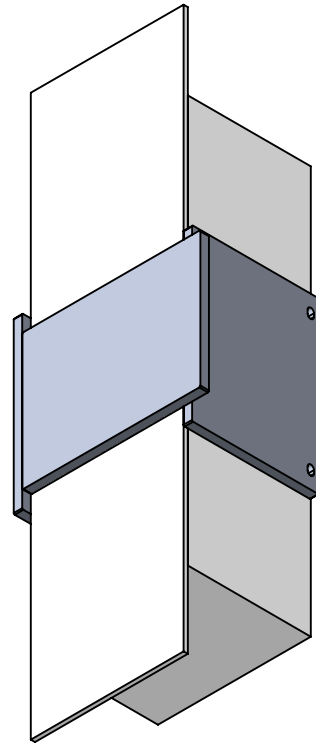
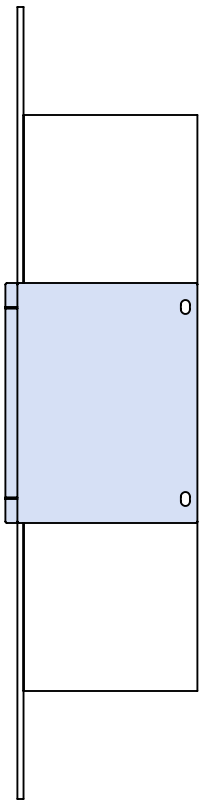
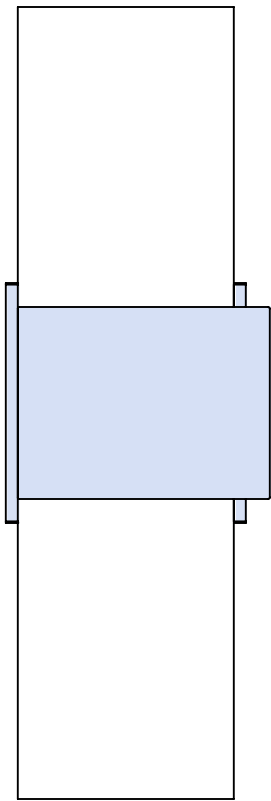
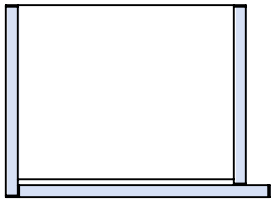

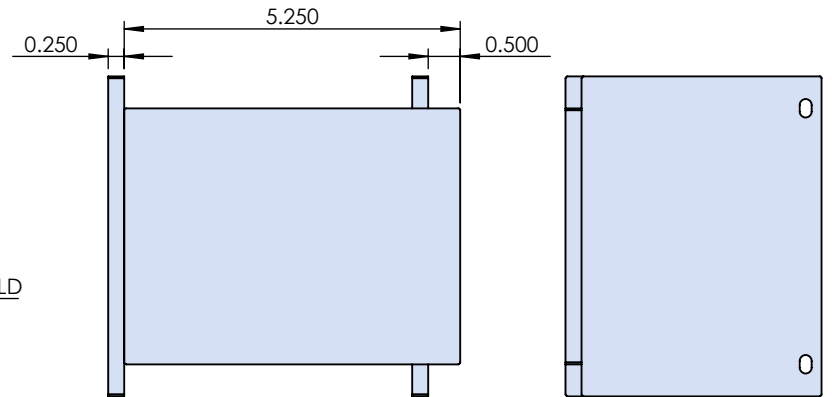
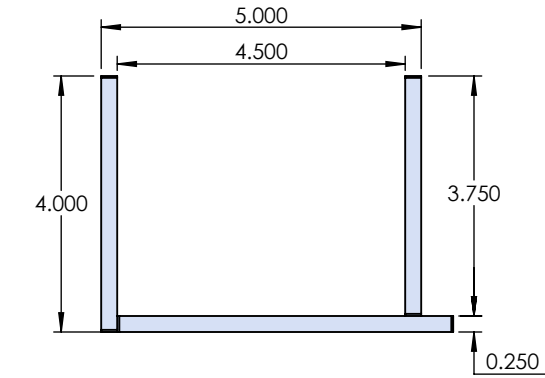
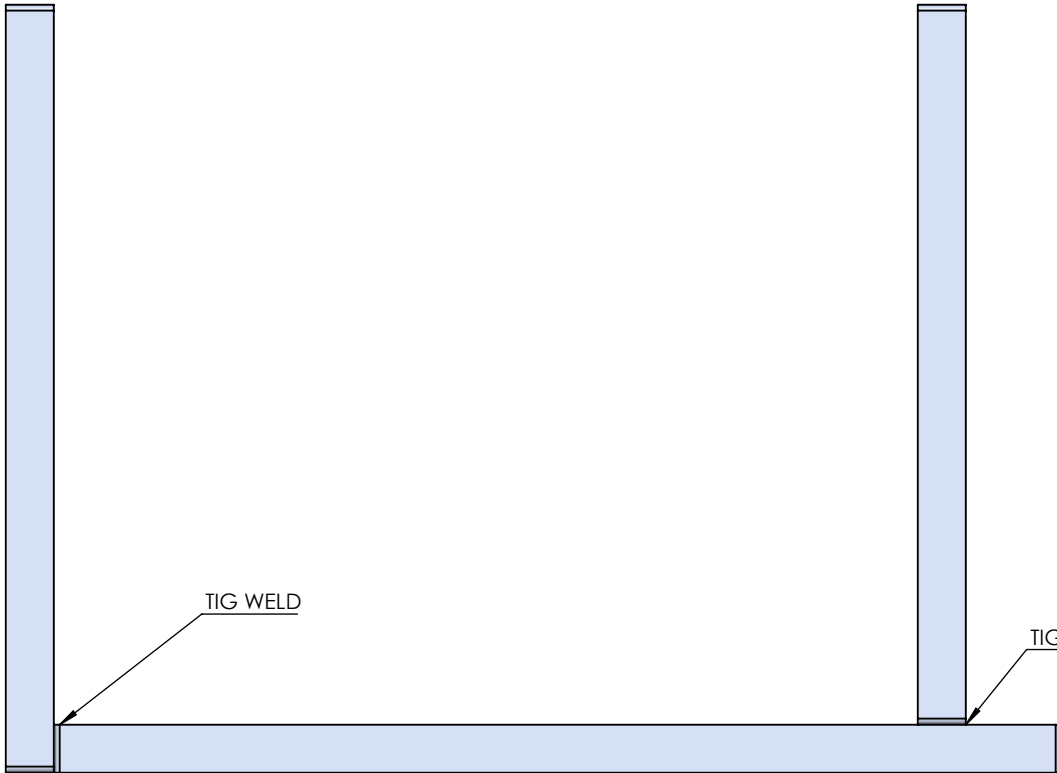
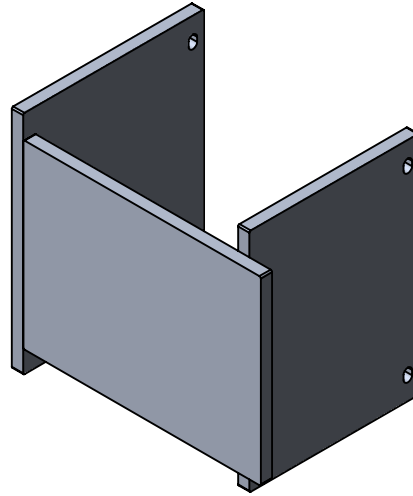
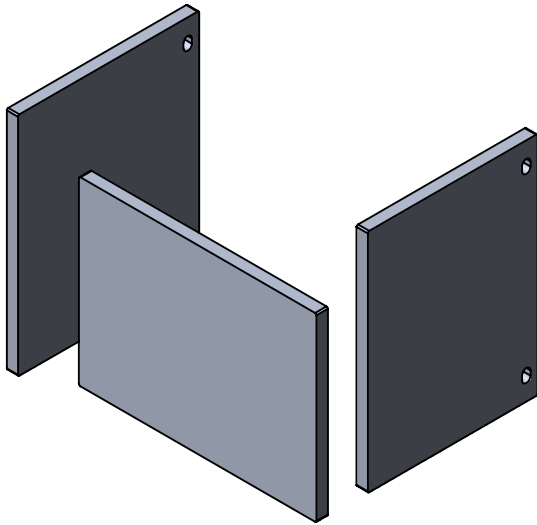

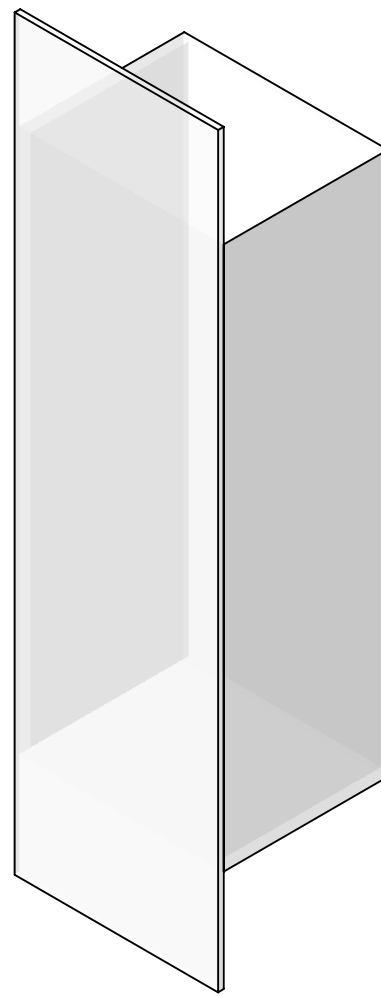
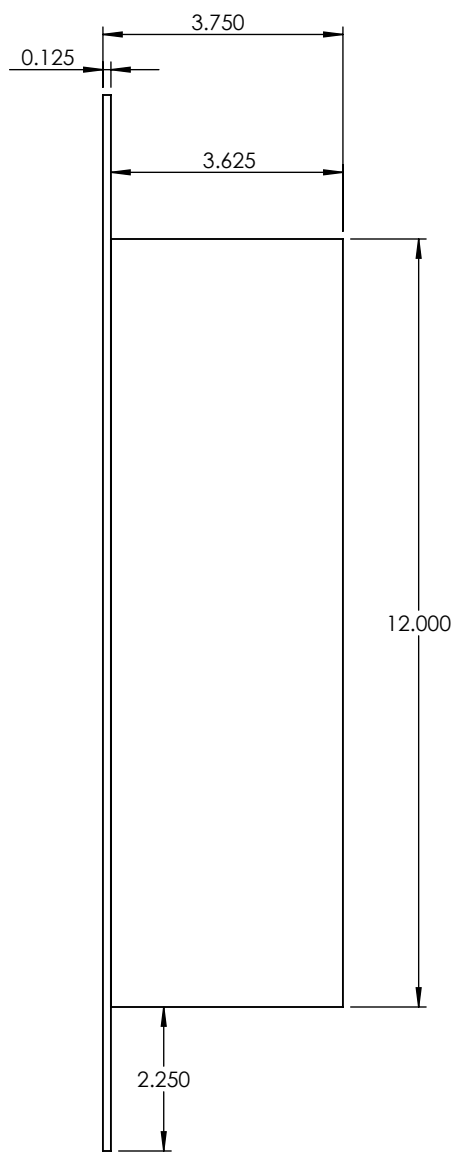
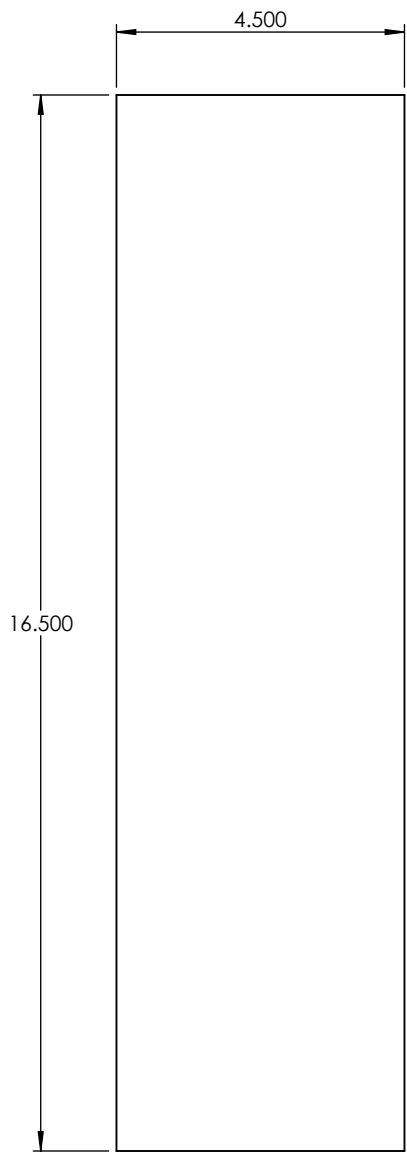

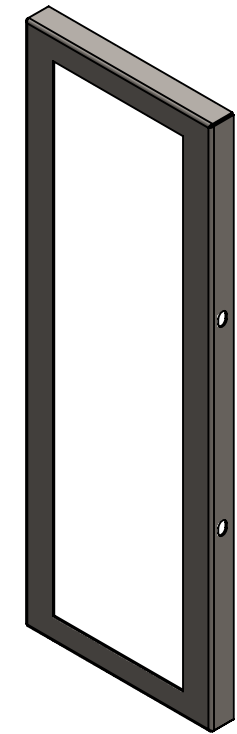
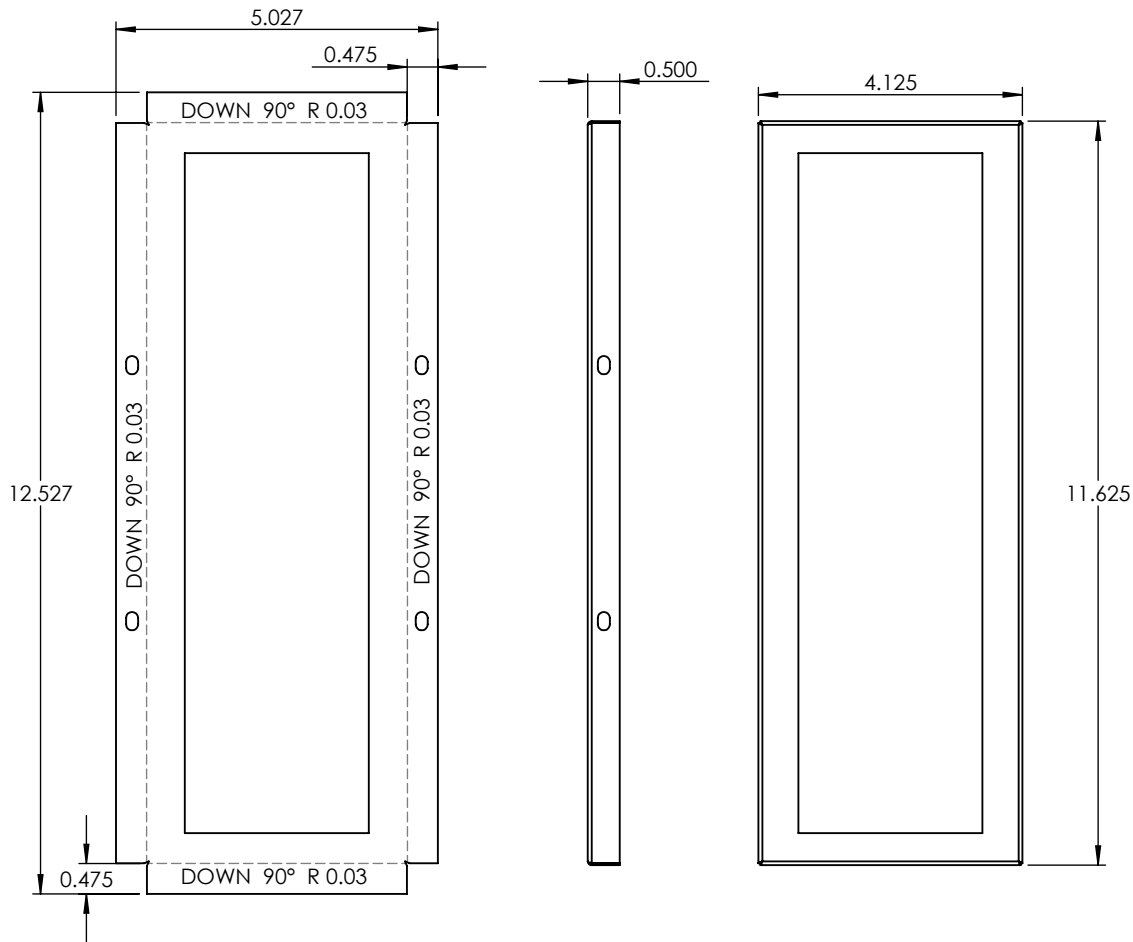

PROPRIETARY AND CONFIDENTIAL
 THE INFORMATION CONTAINED IN THIS DRAWING IS THE SOLE PROPERTY OF <INSERT COMPANY NAME HERE>. ANY REPRODUCTION IN PART OR AS A WHOLE WITHOUT THE WRITTEN PERMISSION OF <INSERT COMPANY NAME HERE> IS PROHIBITED.

		UNLESS OTHERWISE SPECIFIED:	NAME	DATE	22 GAUGE	
		DIMENSIONS ARE IN INCHES TOLERANCES: FRACTIONAL ± ANGULAR: MACH ± BEND ± TWO PLACE DECIMAL ± THREE PLACE DECIMAL ±	DRAWN			
		INTERPRET GEOMETRIC TOLERANCING PER:	CHECKED		ASY-SC16-12W-TR-WF-DIM-40K-ASSEMBLY	
		MATERIAL	ENG APPR.			
		FINISH	MFG APPR.		Q.A.	
NEXT ASSY	USED ON		COMMENTS:		SIZE	DWG. NO.
APPLICATION		DO NOT SCALE DRAWING			A	REV
					SCALE: 1:3	WEIGHT:
					SHEET 5 OF 7	

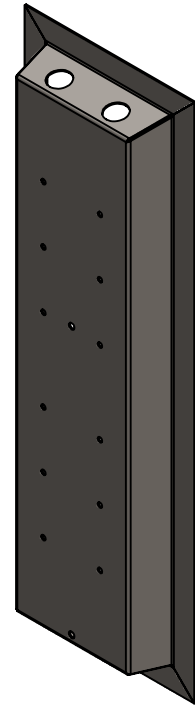
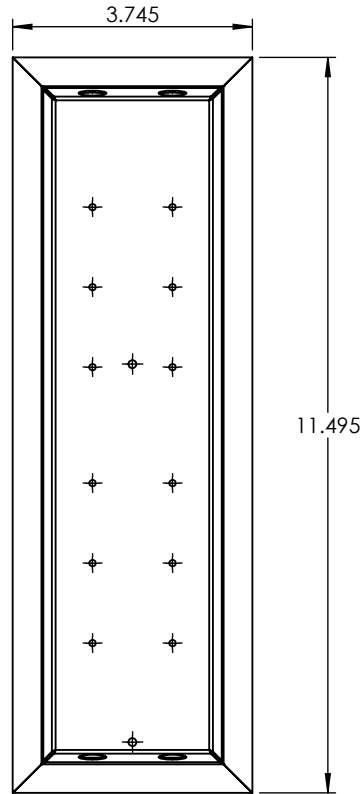
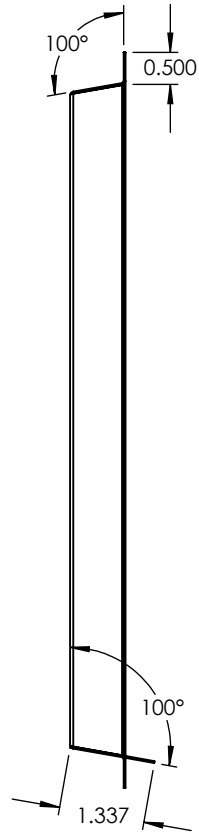
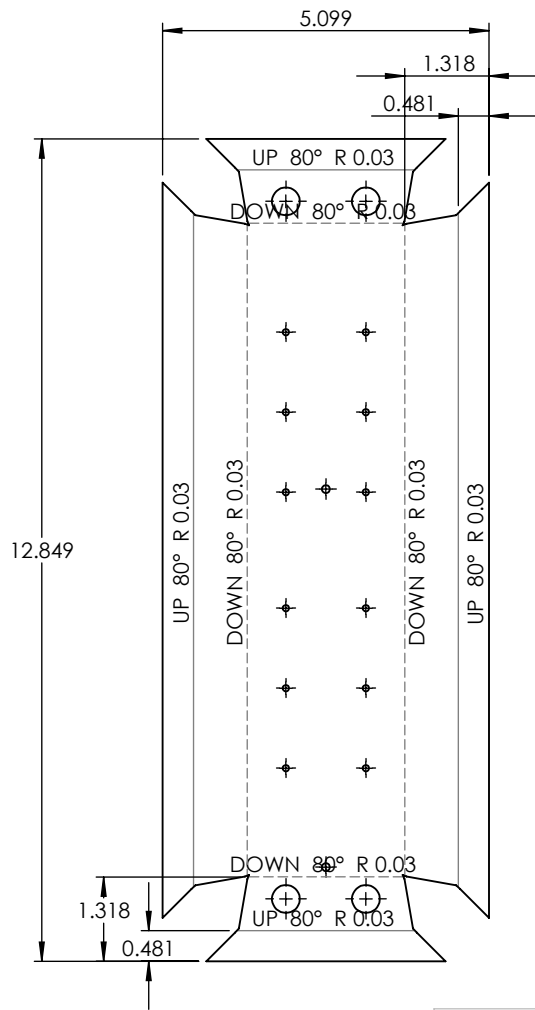

PROPRIETARY AND CONFIDENTIAL
 THE INFORMATION CONTAINED IN THIS DRAWING IS THE SOLE PROPERTY OF <INSERT COMPANY NAME HERE>. ANY REPRODUCTION IN PART OR AS A WHOLE WITHOUT THE WRITTEN PERMISSION OF <INSERT COMPANY NAME HERE> IS PROHIBITED.

		UNLESS OTHERWISE SPECIFIED:	NAME	DATE	22 GAUGE	
		DIMENSIONS ARE IN INCHES TOLERANCES: FRACTIONAL ± ANGULAR: MACH ± BEND ± TWO PLACE DECIMAL ± THREE PLACE DECIMAL ±	DRAWN			
		INTERPRET GEOMETRIC TOLERANCING PER:	CHECKED		SIZE DWG. NO. REV	
		MATERIAL	ENG APPR.			
		FINISH	MFG APPR.			
NEXT ASSY	USED ON		Q.A.			
APPLICATION		DO NOT SCALE DRAWING	COMMENTS:			

5

4

3

2

1

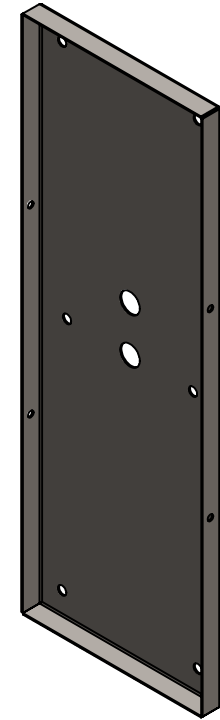
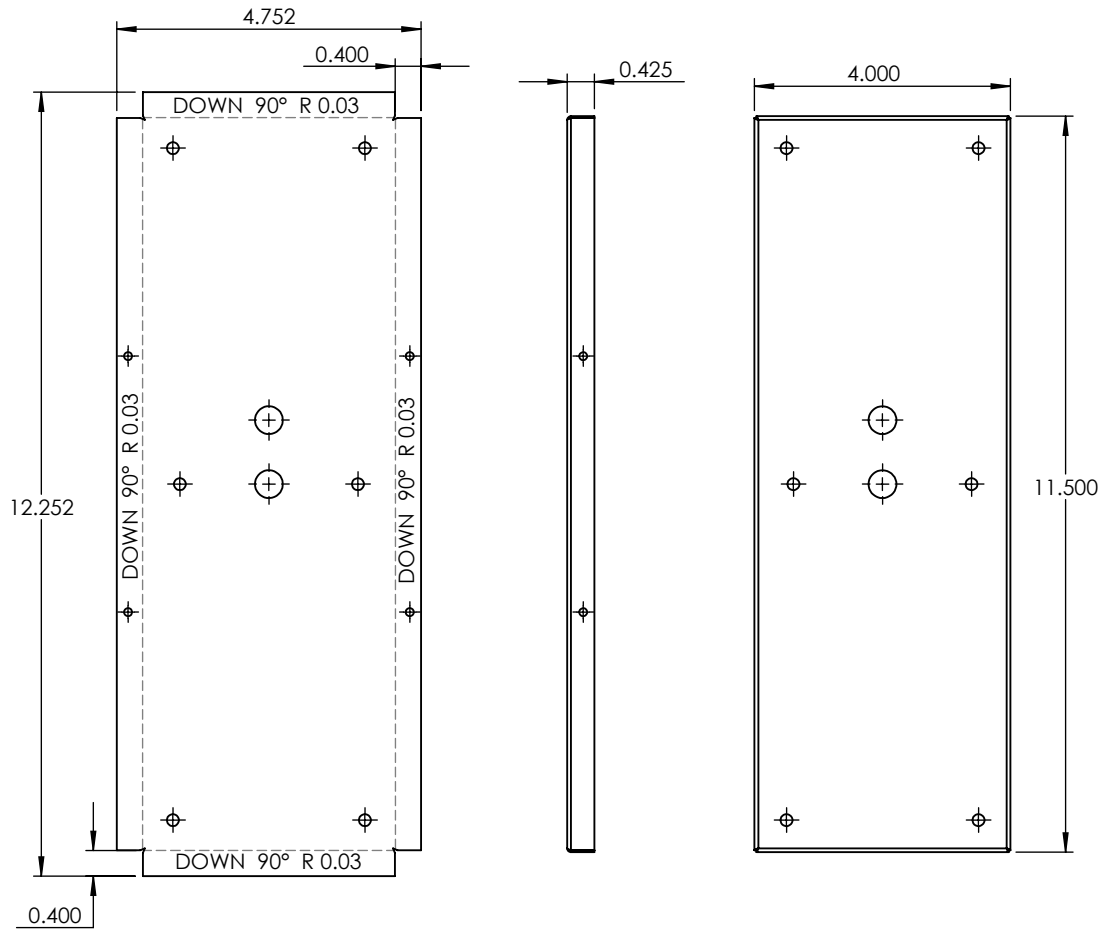

PROPRIETARY AND CONFIDENTIAL
 THE INFORMATION CONTAINED IN THIS DRAWING IS THE SOLE PROPERTY OF <INSERT COMPANY NAME HERE>. ANY REPRODUCTION IN PART OR AS A WHOLE WITHOUT THE WRITTEN PERMISSION OF <INSERT COMPANY NAME HERE> IS PROHIBITED.

		UNLESS OTHERWISE SPECIFIED:		NAME	DATE	22 GAUGE		
		DIMENSIONS ARE IN INCHES TOLERANCES: FRACTIONAL ± ANGULAR: MACH ± BEND ± TWO PLACE DECIMAL ± THREE PLACE DECIMAL ±	DRAWN					TITLE:
		INTERPRET GEOMETRIC TOLERANCING PER:	CHECKED			ASY-SC16-12W-TR-WF-DIM-40K-ASSEMBLY		
		MATERIAL	ENG APPR.					
		FINISH	MFG APPR.			SIZE	DWG. NO.	REV
NEXT ASSY	USED ON		Q.A.			A		
APPLICATION		DO NOT SCALE DRAWING	COMMENTS:			SCALE: 1:3	WEIGHT:	SHEET 7 OF 7

5

4

3

2

1